

**WILLIAM PENN SCHOOL MODERNIZATION**  
BAKERSFIELD CITY SCHOOL DISTRICT  
BAKERSFIELD, CALIFORNIA

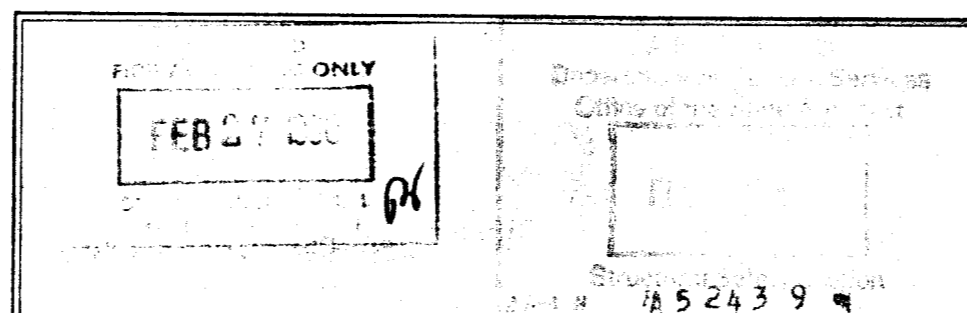

2115 19th street • bakersfield, ca 93301 • (805) 322-1863  
*William Penn* ARCHITECTS • PLANNERS  
 Kendrick Design Group

- NOTES LISTED IN THIS COLUMN WHICH ARE NOT INDICATED ON THE DRAWING SHALL BE CONSIDERED AS PART OF THE WORK. NOTES FOR REVISIONS ARE LISTED IN THE REVISIONS COLUMN. NOTES FOR REVISIONS ARE LISTED IN THE REVISIONS COLUMN. NOTES FOR REVISIONS ARE LISTED IN THE REVISIONS COLUMN.
- LEGEND
- (N) - NEW
  - (R) - REPAIR
  - (D) - DEMOLITION
  - AS SHOWN - AS SHOWN DETAILS, REFERRED TO
- 1. (R) GLAZING TO REMAIN.
  - 2. (R) 2 X 6 STUDS @ 16" O.C. W/MT. FLYWD AND DRT. PLASTER TO REMAIN.
  - 3. (R) 10 W/F-21 COLUMN TO REMAIN.
  - 4. (R) 18 W/F-27 TO REMAIN.
  - 5. (R) 2 X 4 UNPAINTED ROOF DECKING TO REMAIN.
  - 6. (R) 1 1/2" RIGID INSULATION/SHALT SHINGLES TO REMAIN. DEMO.
  - 7. (R) GLAZING SYSTEM TO REMAIN.
  - 8. (R) GLAZING SYSTEM TO BE REMOVED.
  - 9. (R) ACQUISITION/TESTING TO REMAIN. DEMO/REPAIR FOR (N) TANK CEILING. REPLACE CLEAN AND REPAINT DAMAGING DRIVERS AND APPURTENANT ITEMS TO BE REMOVED.
  - 10. (R) PROVIDE & INSTALL R30 LAY-IN BATT INSULATION AS SHOWN.
  - 11. (R) PROVIDE & INSTALL (N) SUSPENDED T-BAW CEILING W/2 X 4 GRID & ACQUISITION PANELS AS SHOWN.
  - 12. (R) PROVIDE & INSTALL (N) DAMAGING DRIVE APPURTENANT ITEMS AS SHOWN. (INCLUDING TRUCK TO REMAIN AND BE REPAINTED).

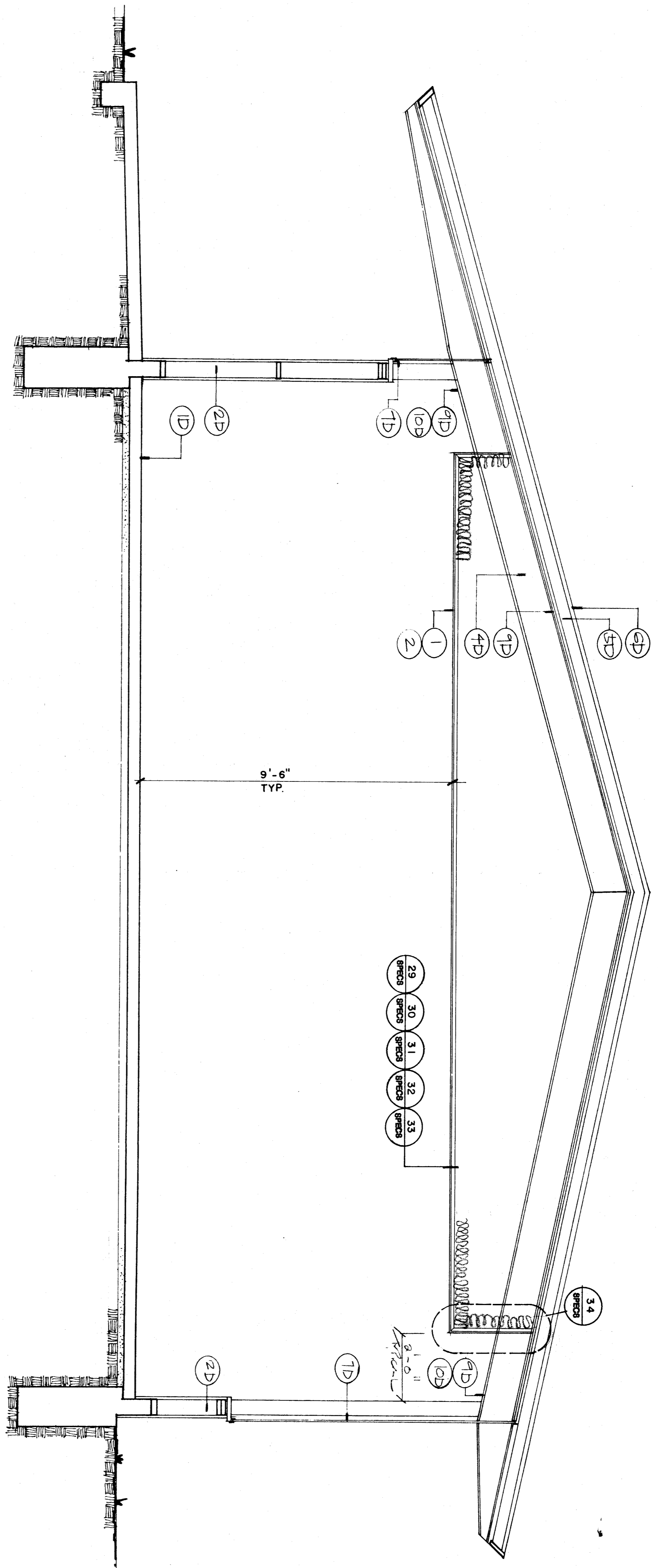

**SECTION A-A**

1/2" = 1'-0"

TITLE 24 & 1979 198C

52439 6/2/89

job number  
8711  
sheet number