

FLUSH TRANSITION AT BOTTOM OF RAMP SCALE: 6" = 1'-0" 15

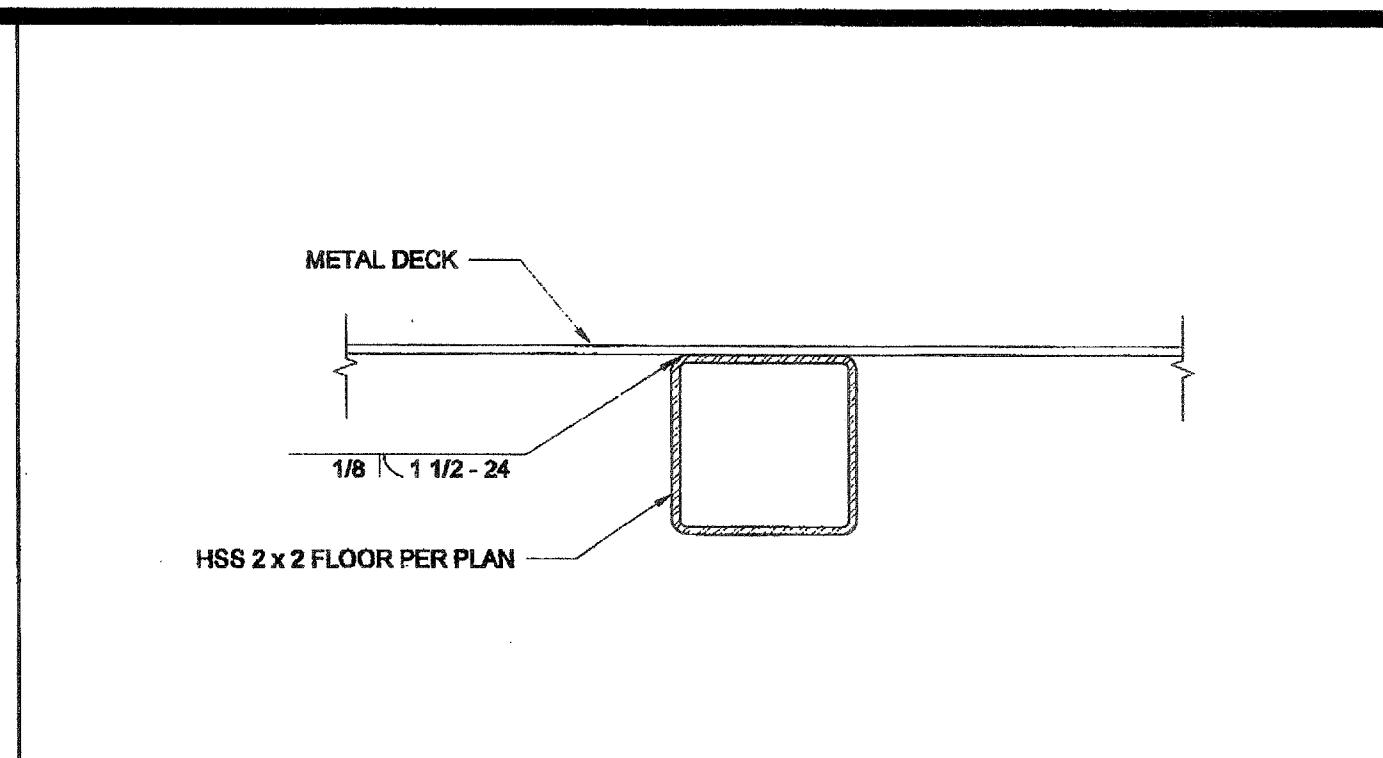

DECK TO FRAME SCALE: 6" = 1'-0" 10

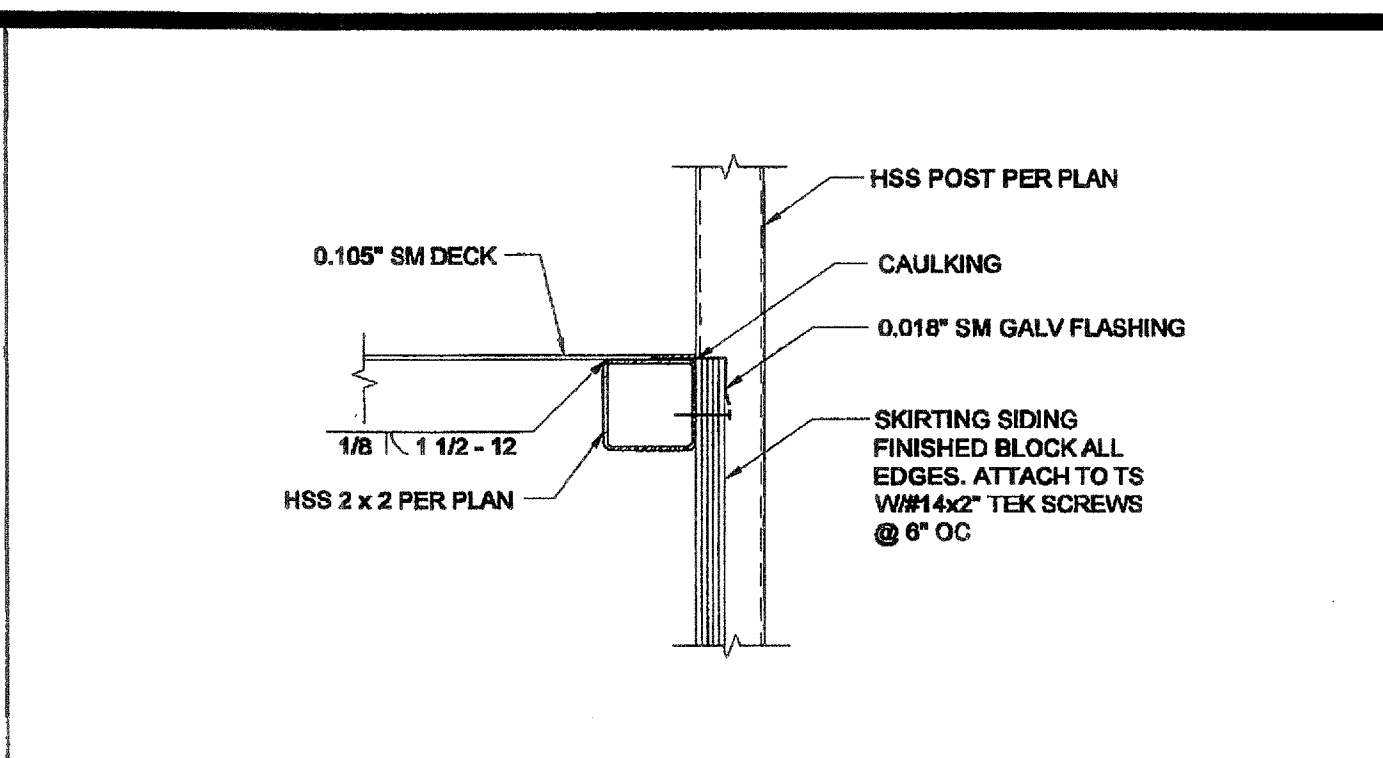

SKIRT FLASHING SCALE: 3" = 1'-0" 5

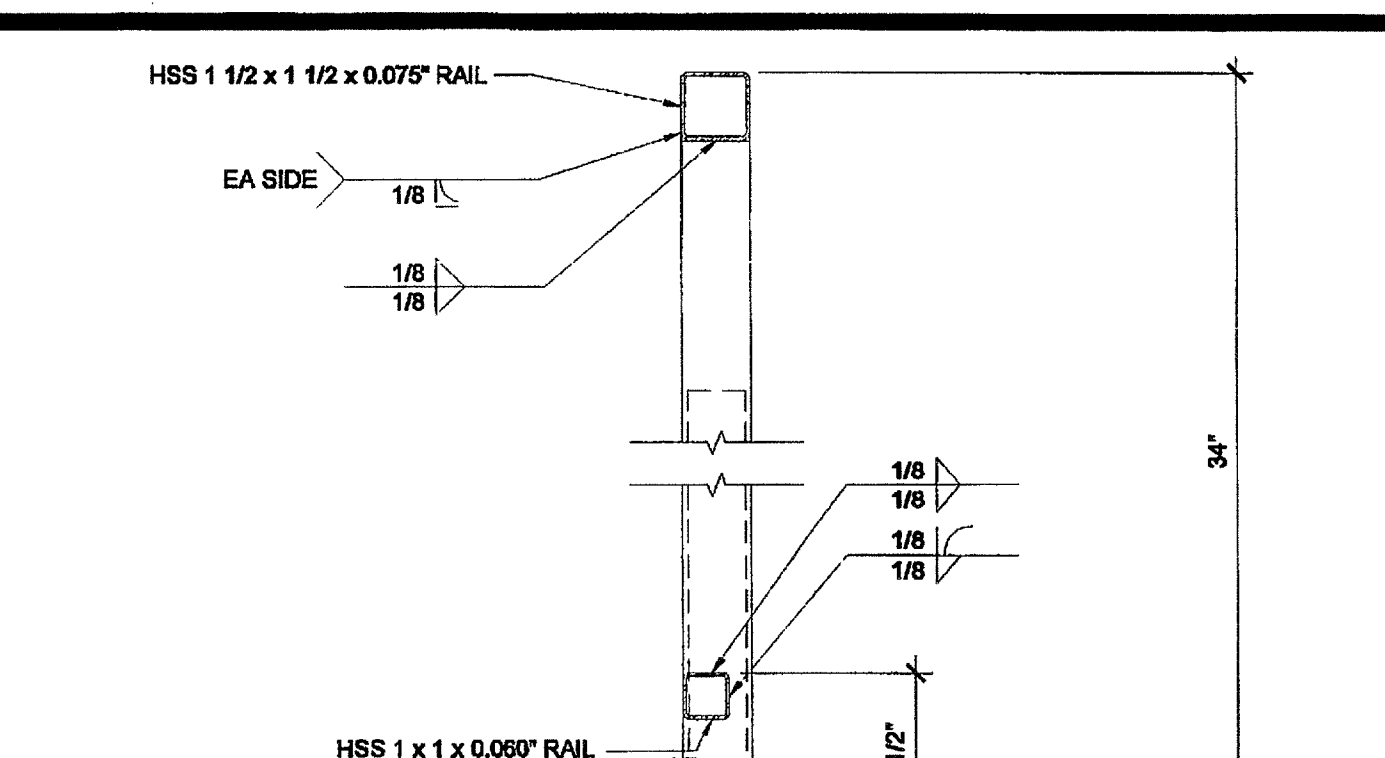

ADJUSTABLE LEG SCALE: 3" = 1'-0" 1

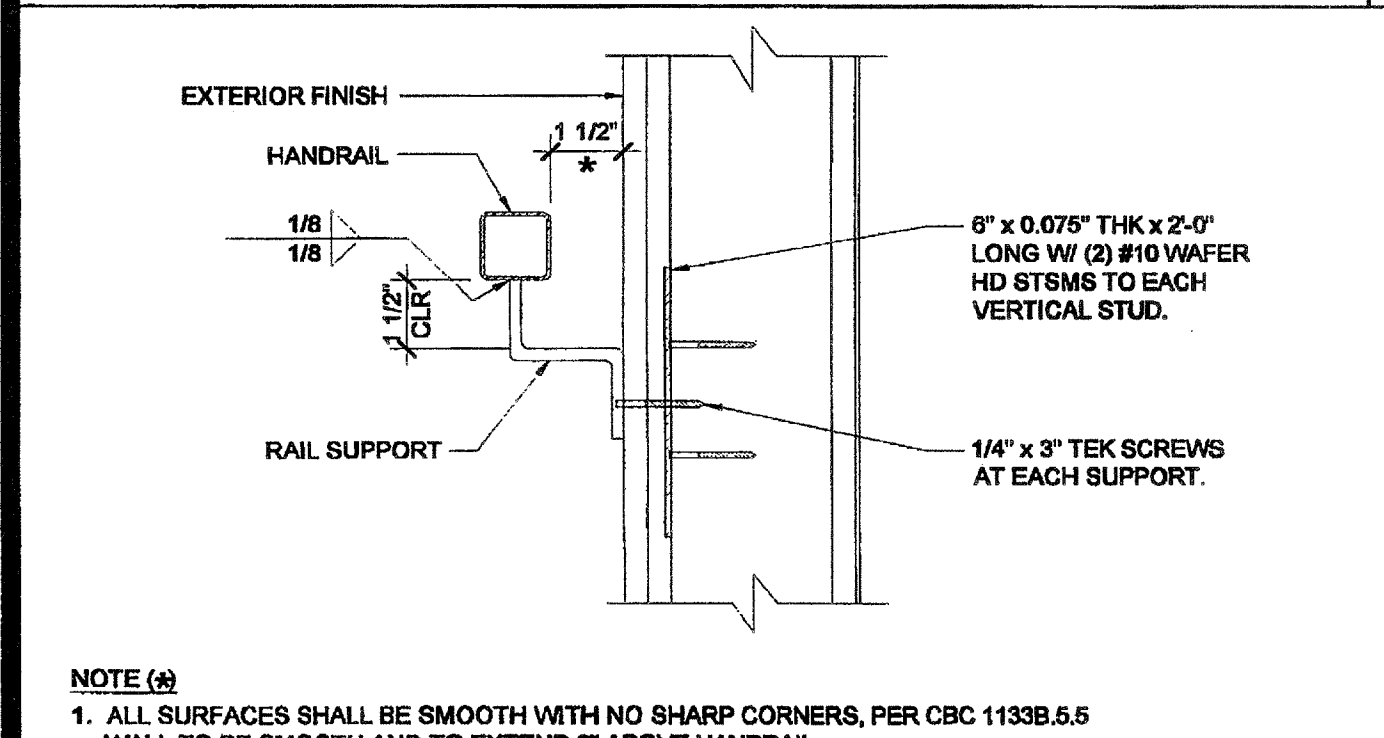

HANDRAIL CONNECTION AT SHEETMETAL BLKG SCALE: 3" = 1'-0" 16

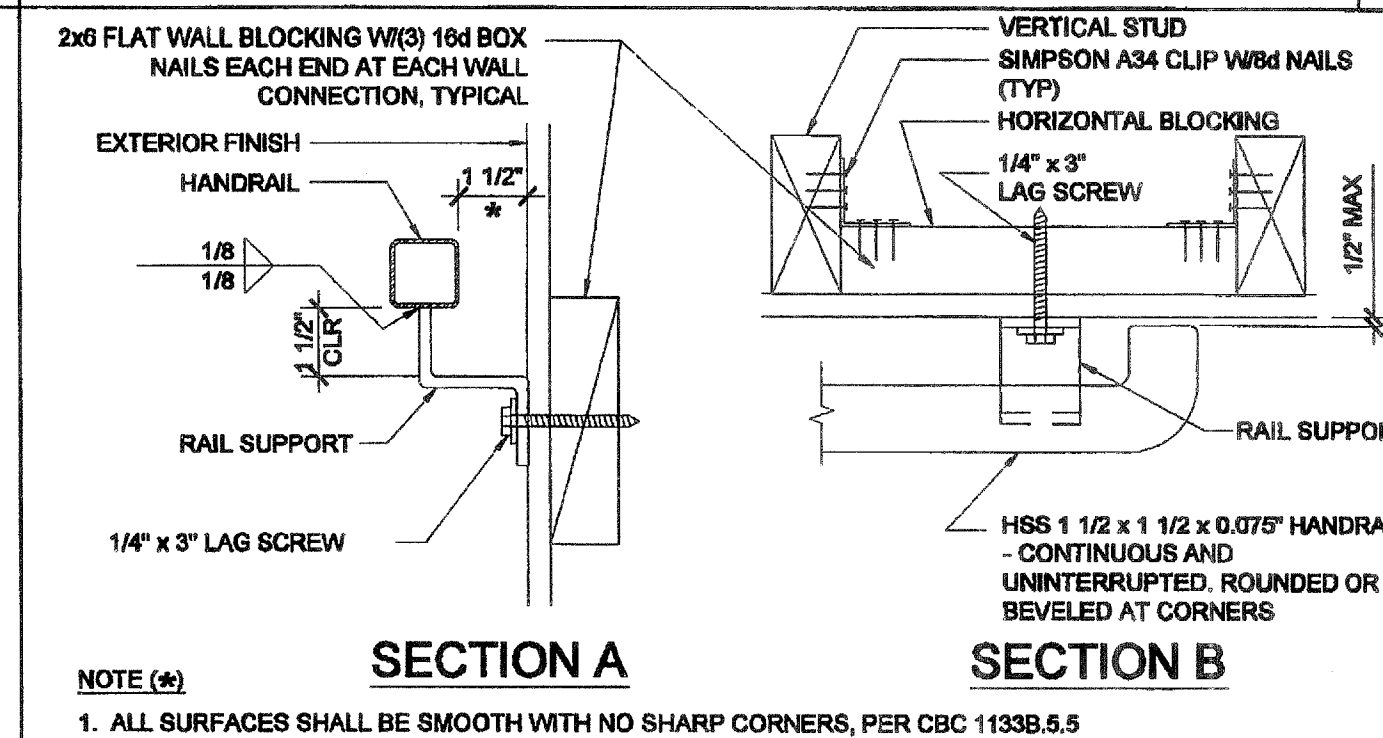

HANDRAIL CONNECTION AT WOOD BLOCKING SCALE: 3" = 1'-0" 11

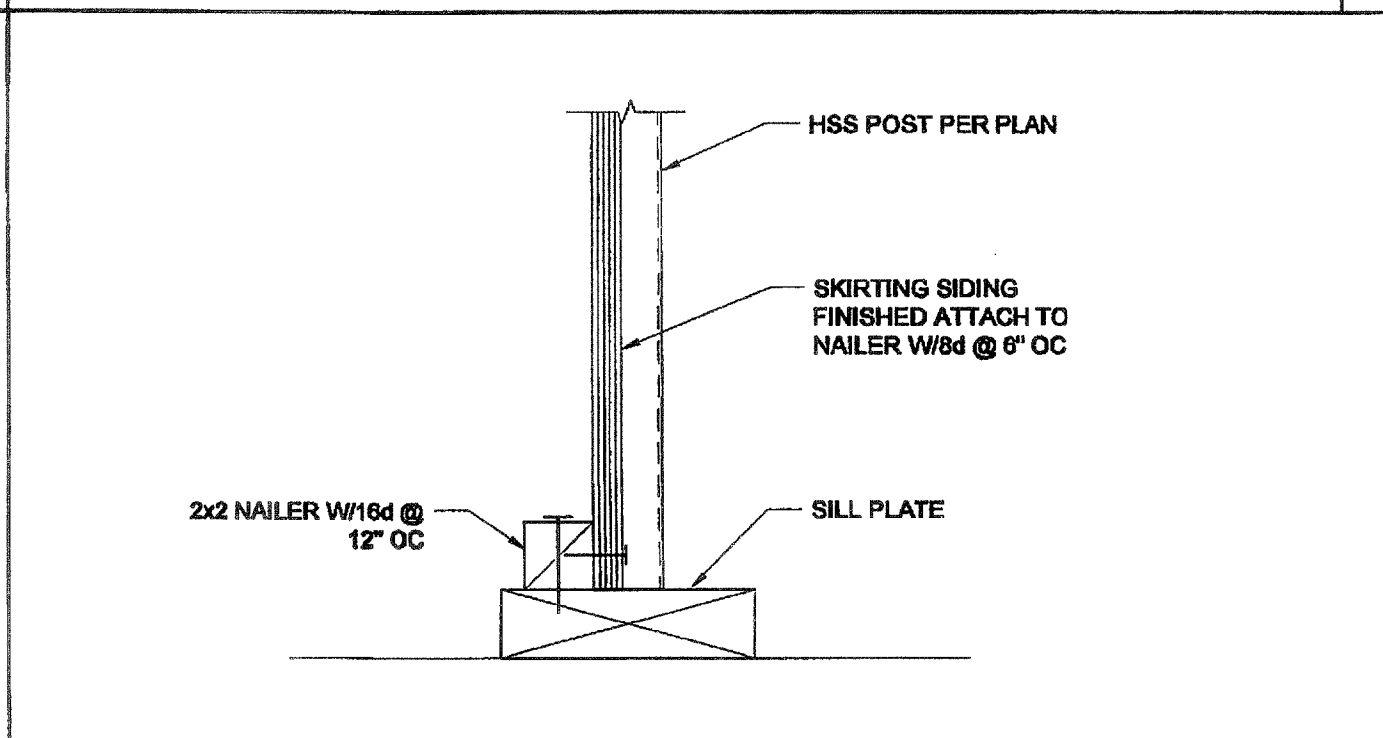

SKIRT FLASHING AT SILL PLATE SCALE: 3" = 1'-0" 6

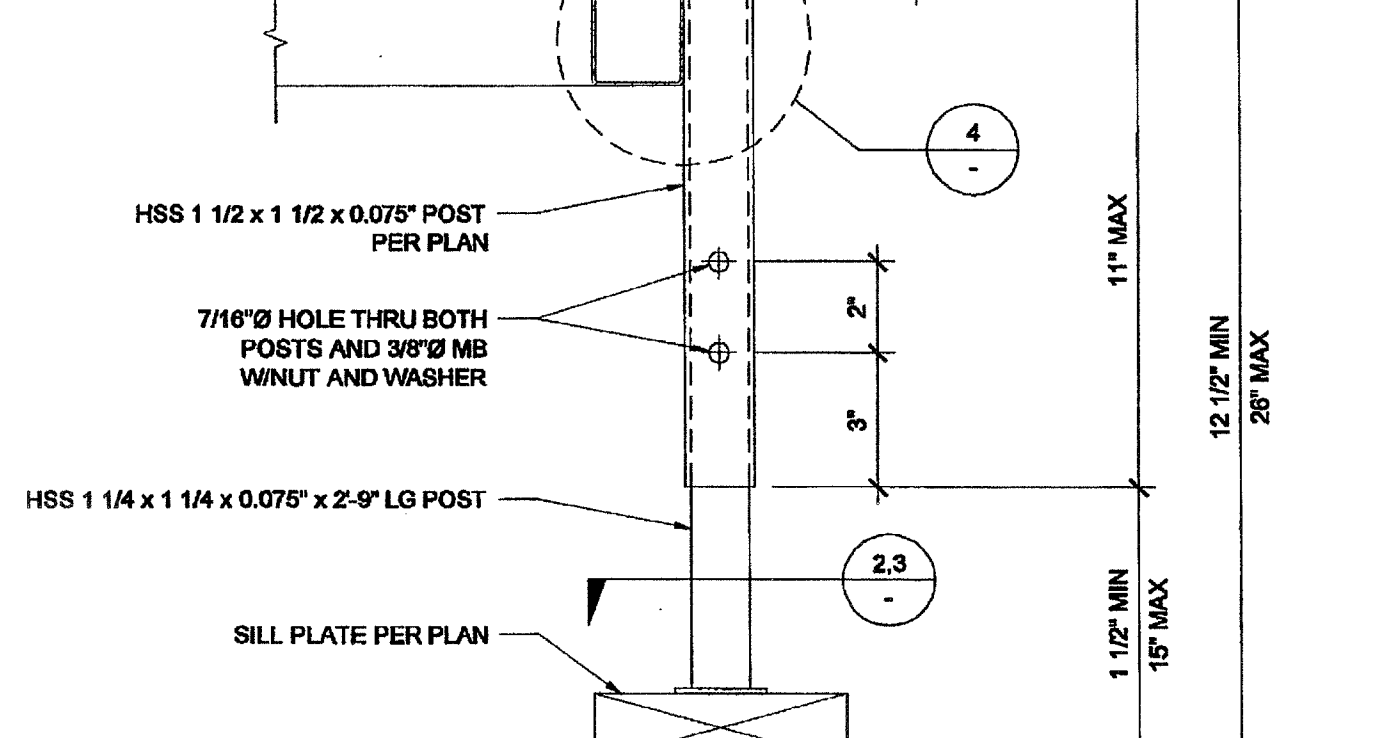

ADJUSTABLE LEG SCALE: 3" = 1'-0" 1

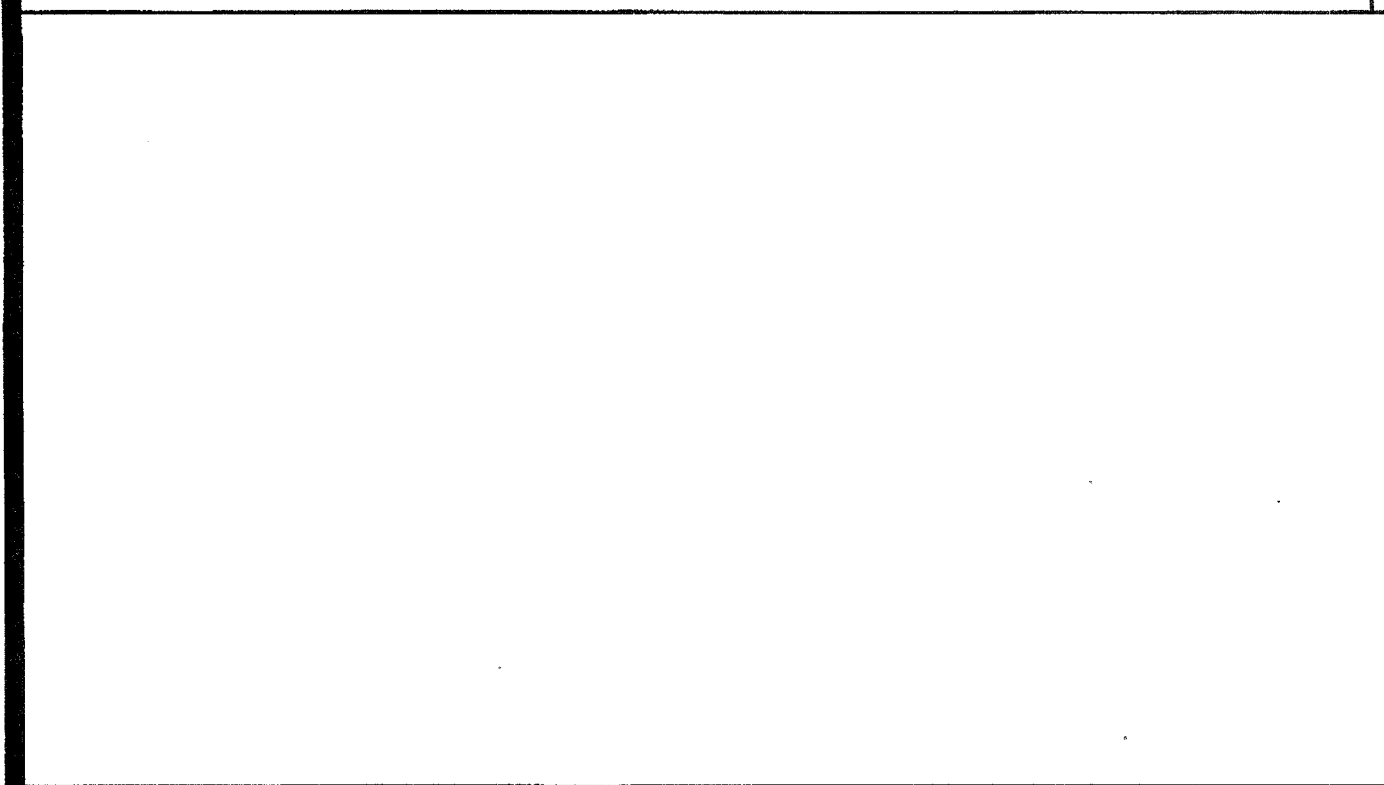

SECTION AT PLATE SCALE: 6" = 1'-0" 17

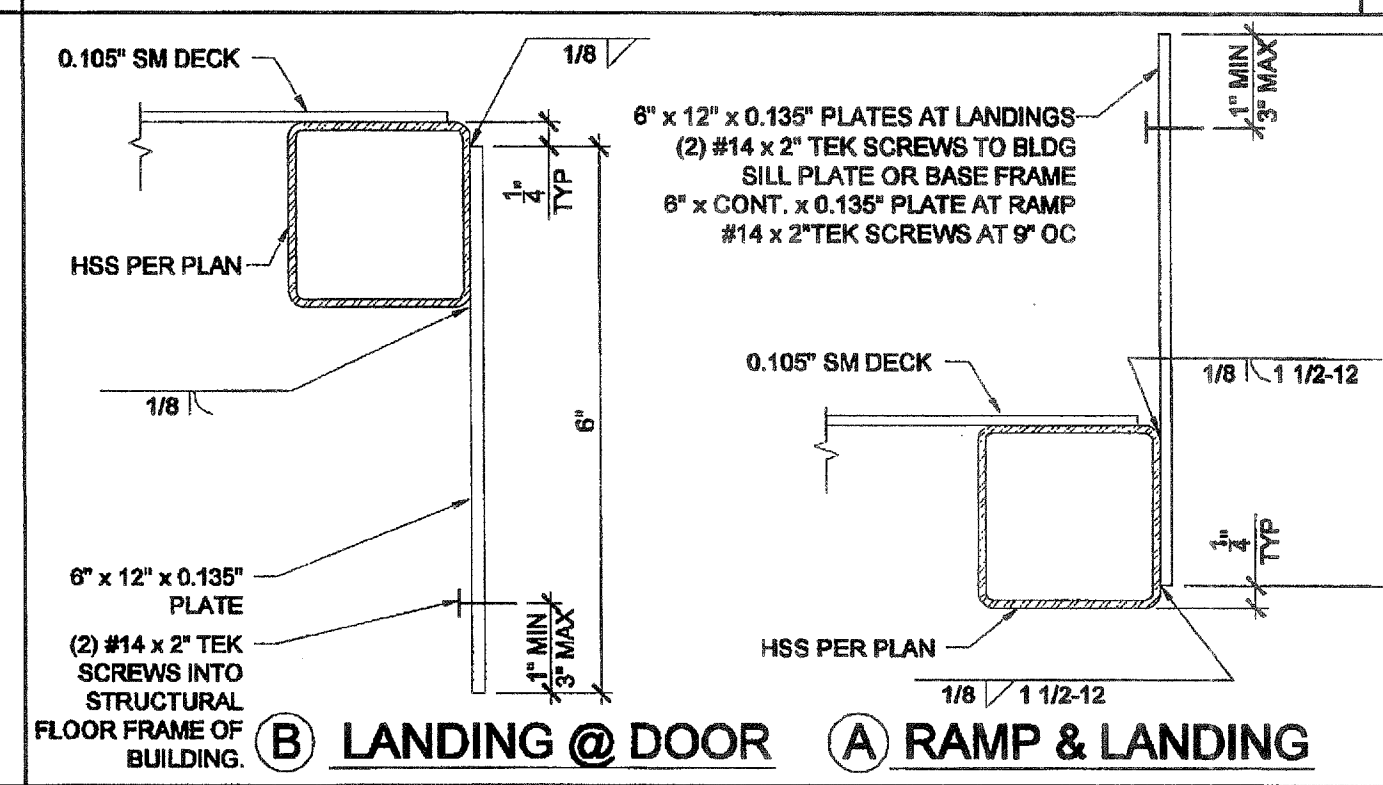

RAMP AT LANDING SCALE: 6" = 1'-0" 12

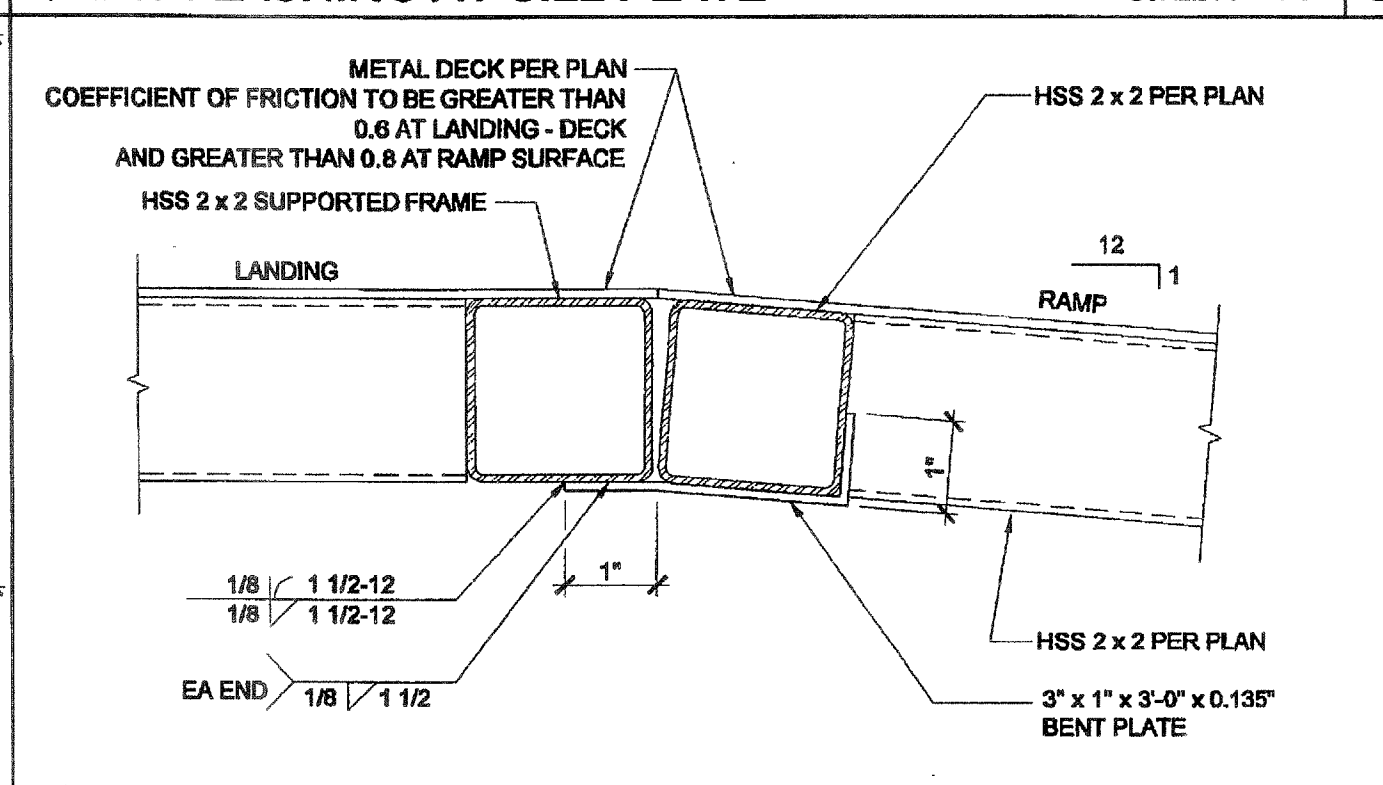

ADJUSTABLE LEG BASE PLATE SCALE: 3" = 1'-0" 2

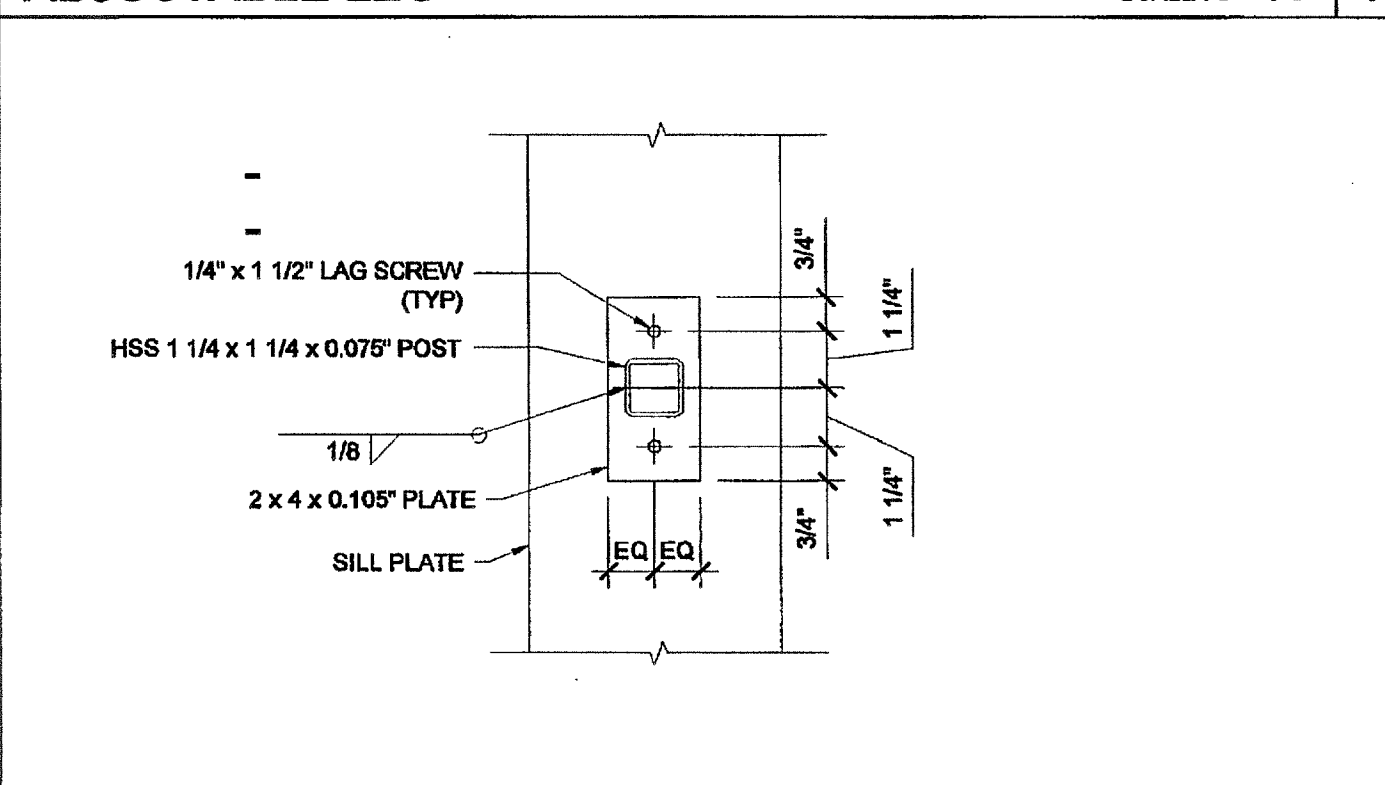

ADJUSTABLE LEG BASE PLATE SCALE: 3" = 1'-0" 3



EXTEND HANDRAIL @ TOP OR BOTT. ENDS SCALE: 3" = 1'-0" 13

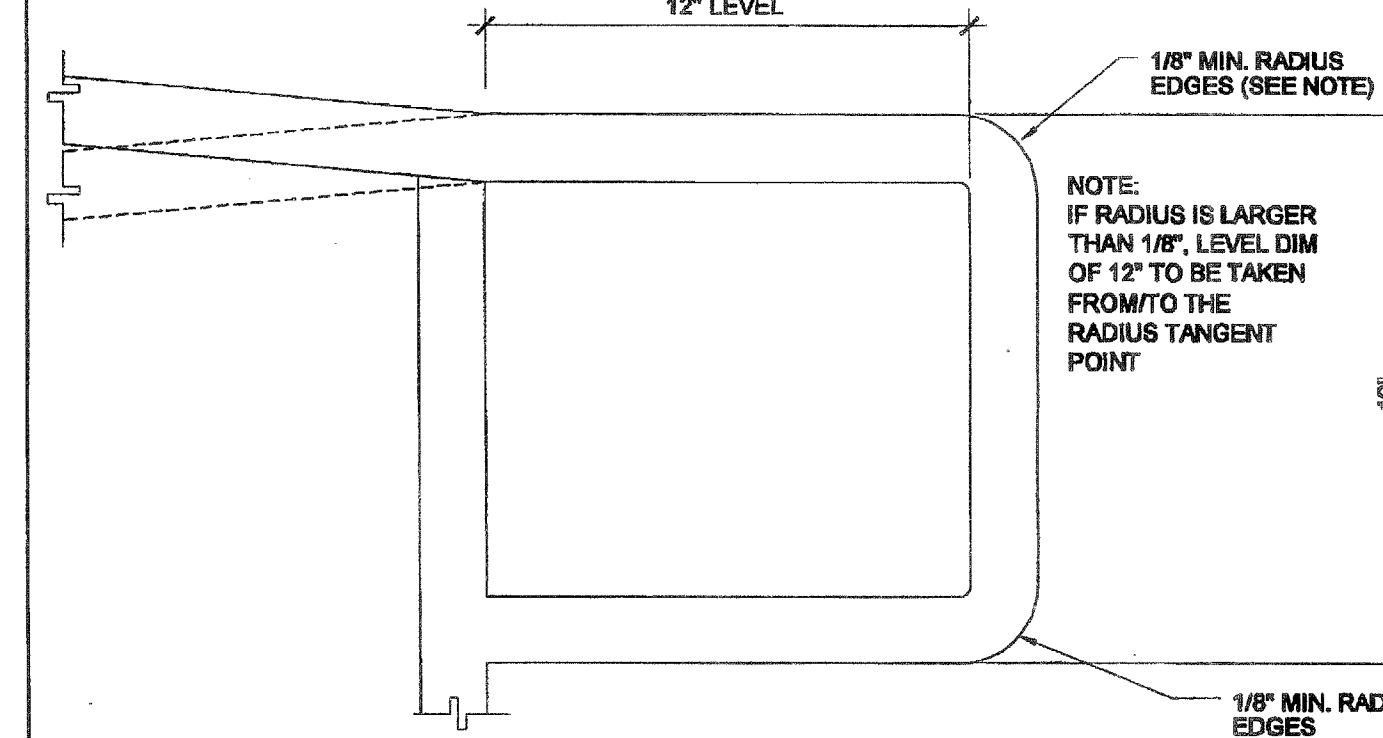

RAMP EXTENSION SCALE: 6" = 1'-0" 8

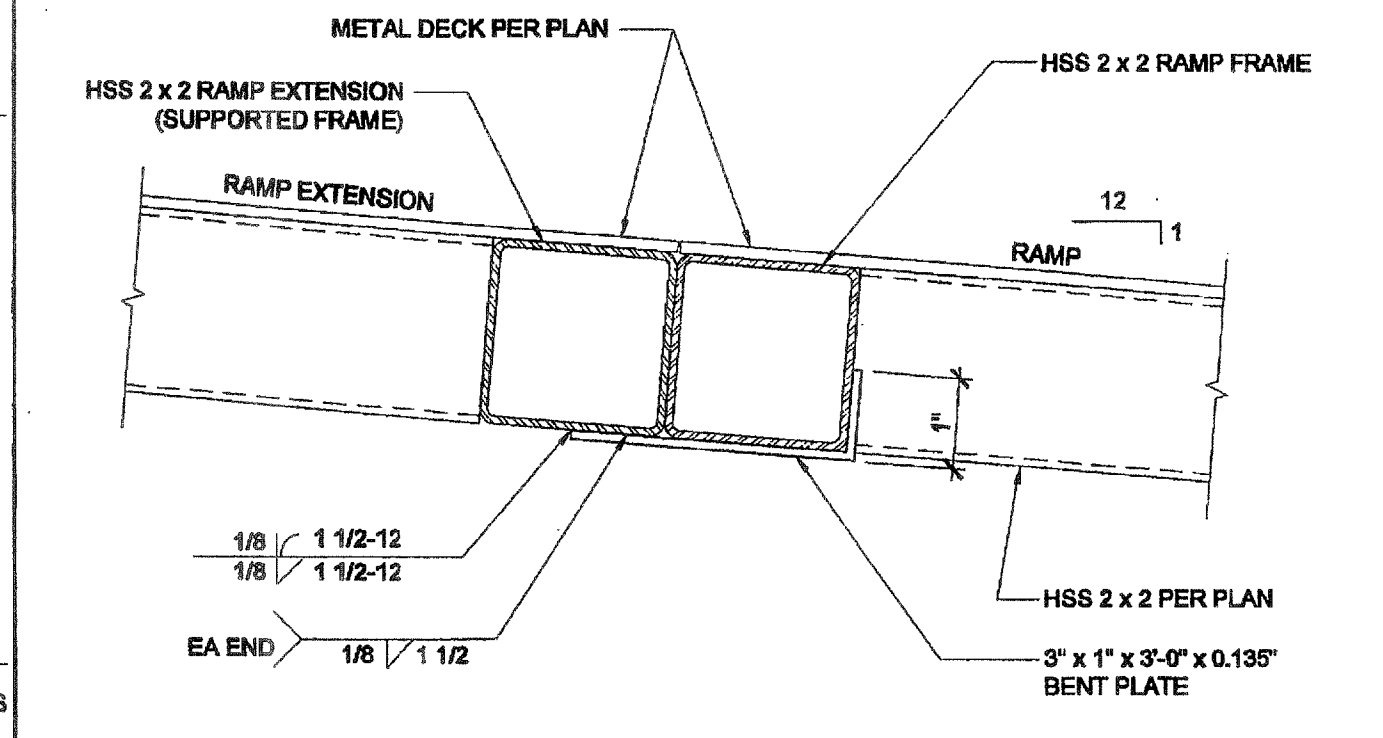

ADJUSTABLE LEG BASE PLATE SCALE: 3" = 1'-0" 3

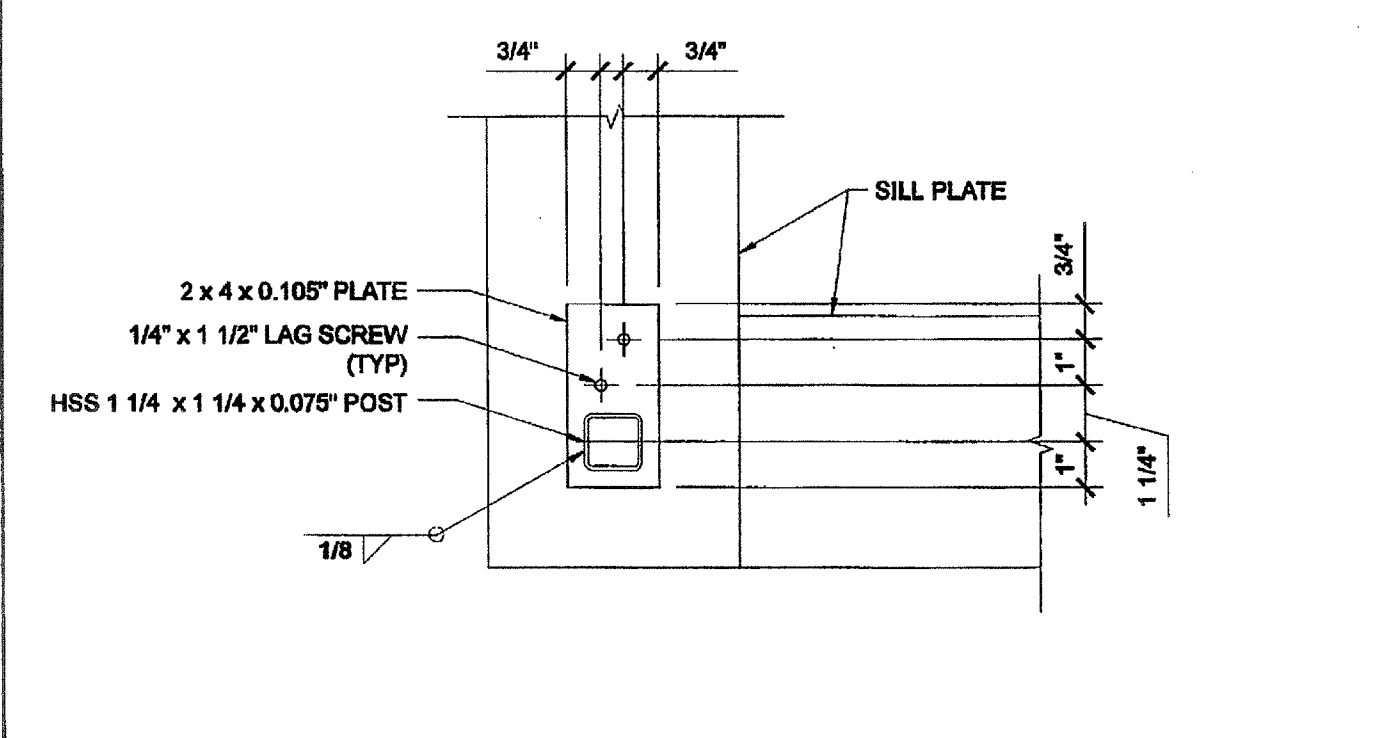

GUARDRAIL POST ATTACHMENT SCALE: 6" = 1'-0" 4

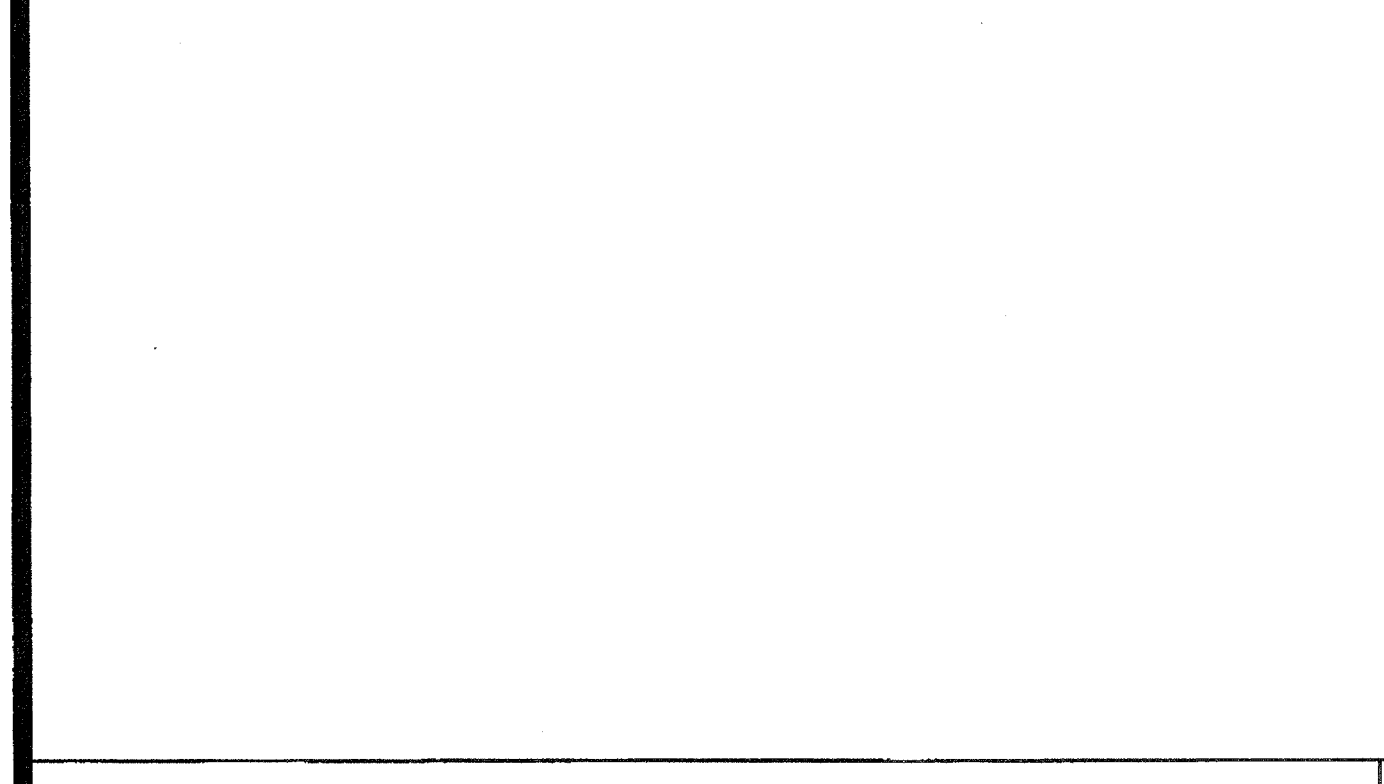

INTERIOR LANDING LEG SECTION SCALE: 3" = 1'-0" 14

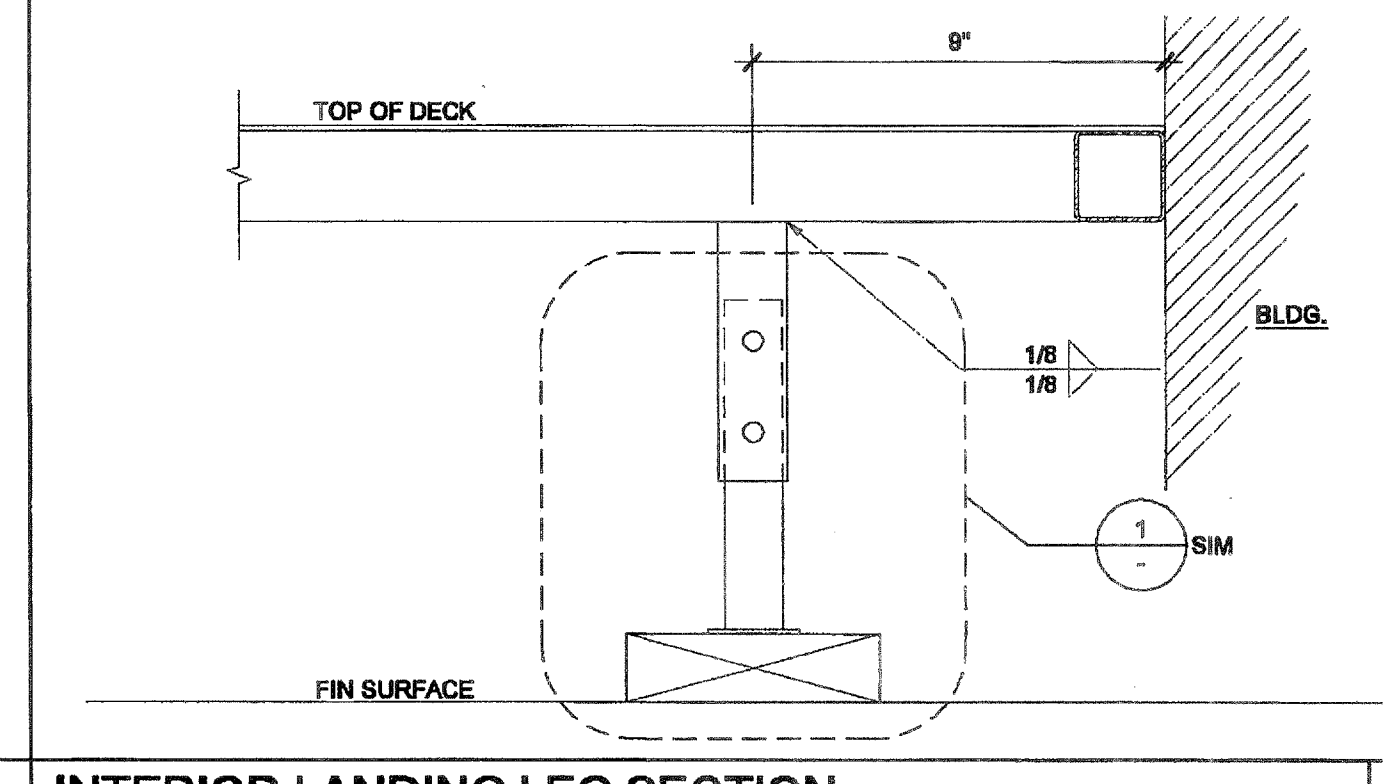

BASE PLATE AT RAMP TOE SCALE: 3" = 1'-0" 9

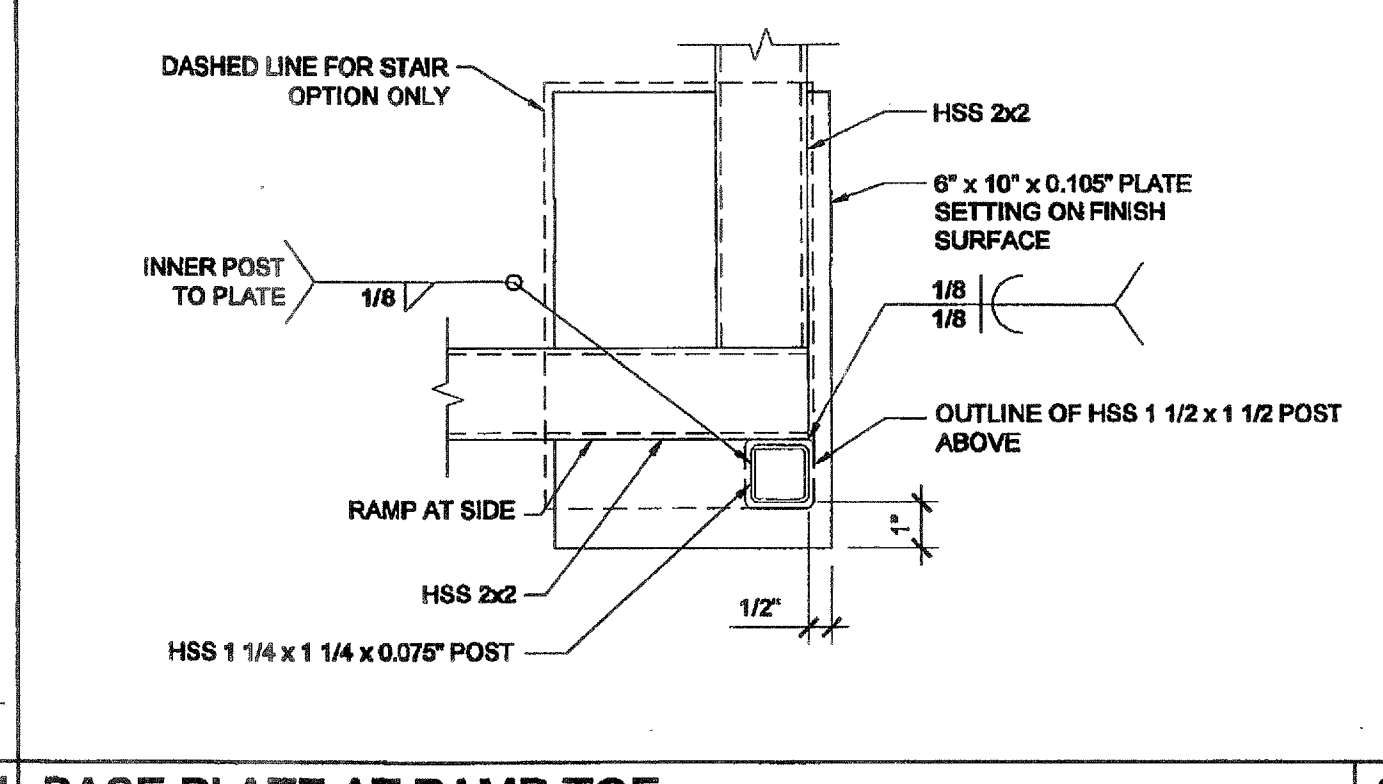

GUARDRAIL POST ATTACHMENT SCALE: 6" = 1'-0" 4

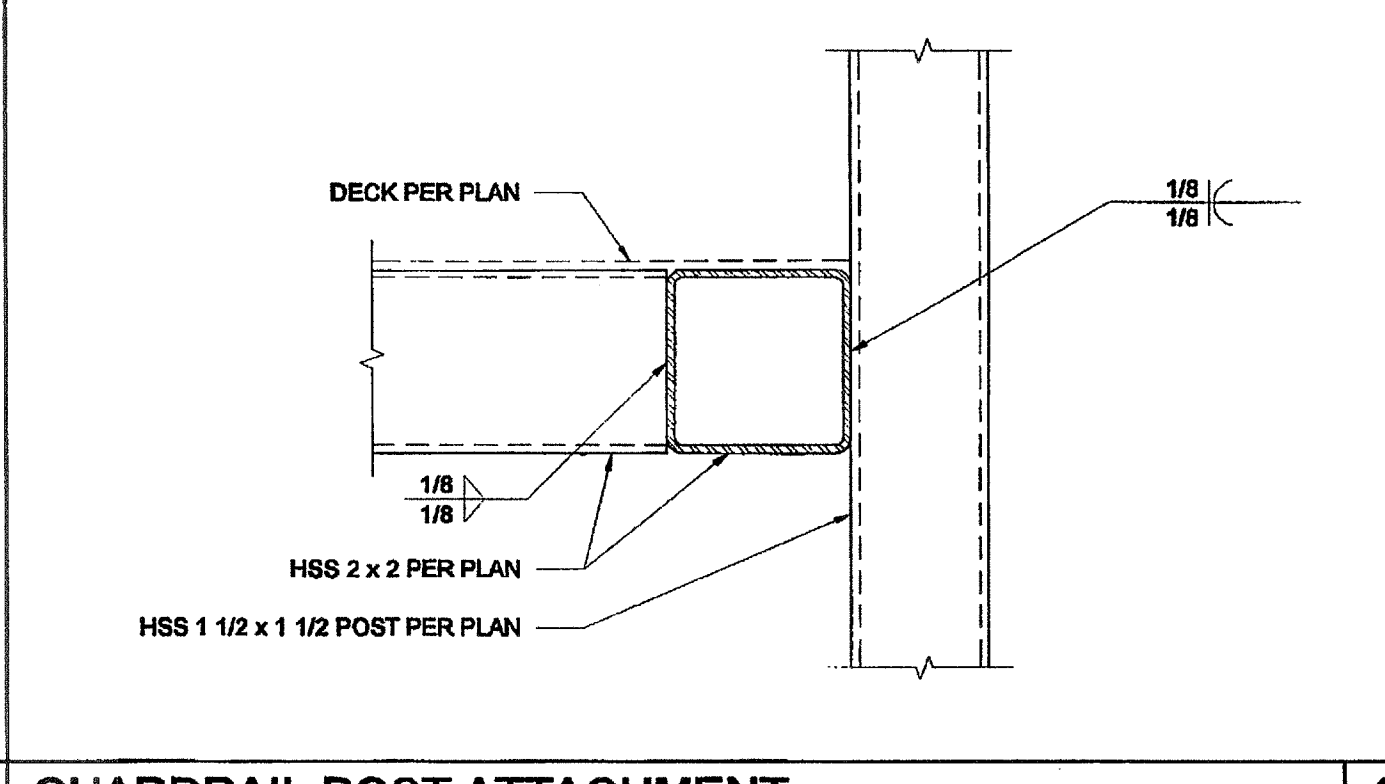

GUARDRAIL POST ATTACHMENT SCALE: 6" = 1'-0" 4

THESE DRAWINGS AND ALL MATERIAL CONTAINED HEREIN ARE THE PROPERTY OF SILVERCREEK INDUSTRIES, INC (SCI Inc) AND SHALL NOT BE REPRODUCED, COPIED OR OTHERWISE DISPOSED OF DIRECTLY OR INDIRECTLY AND SHALL NOT BE USED IN WHOLE OR IN PART TO ASSIST IN THE MAKING OF OR FOR THE PURPOSE OF FURNISHING ANY INFORMATION FOR THE MAKING OF DRAWINGS, PRINTS, APPARATUS OR PARTS THEREOF WITHOUT THE FULL KNOWLEDGE AND WRITTEN CONSENT OF SCI Inc. ALL PATENTABLE MATERIAL CONTAINED HEREIN AND ORIGINATING WITH SCI Inc SHALL BE THE PROPERTY OF SCI Inc

SILVER CREEK INDUSTRIES, INC.



195 EAST MORGAN FERRIS, CALIFORNIA 92571  
PHONE: 951-943-5393 FAX: 951-943-2211

PROJECT NAME:

CLASS LEASING

SHEET TITLE:

RAMP DETAILS

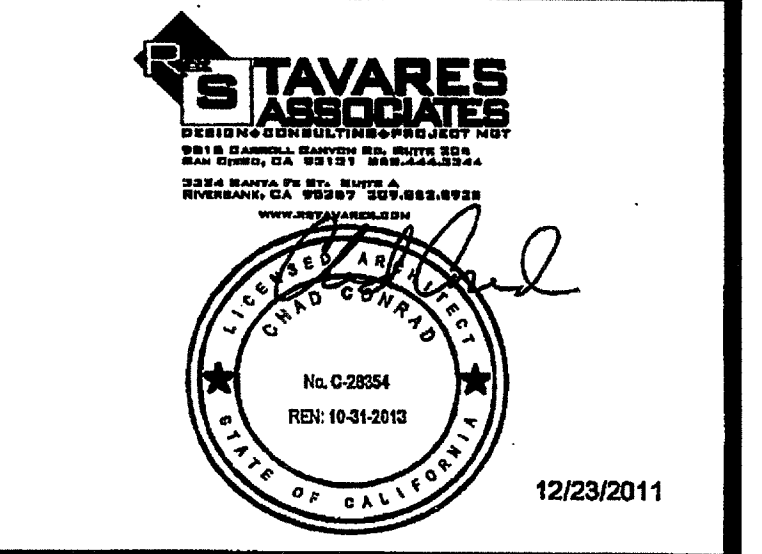

PROJECT SPECIFIC STATE AGENCY APPROVAL

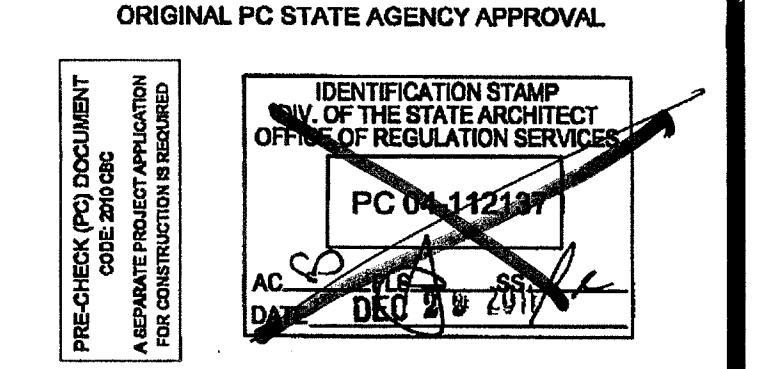
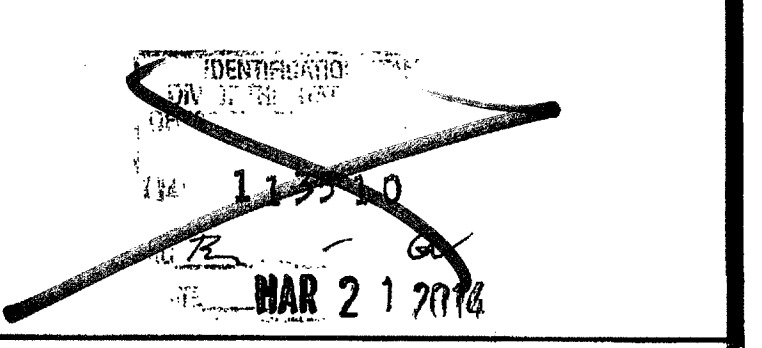

REVISIONS

SILVER CREEK INDUSTRIES 12' x 40' PC

PROJECT NO:

DRAWN BY:

SCALE: AS NOTED

DATE: 6-17-11

P.C. SHEET NUMBER

R-2.01

DATE: MAY 24 2018