

PLAN DETAIL A'-P2
SCALE: 1/4\"/>

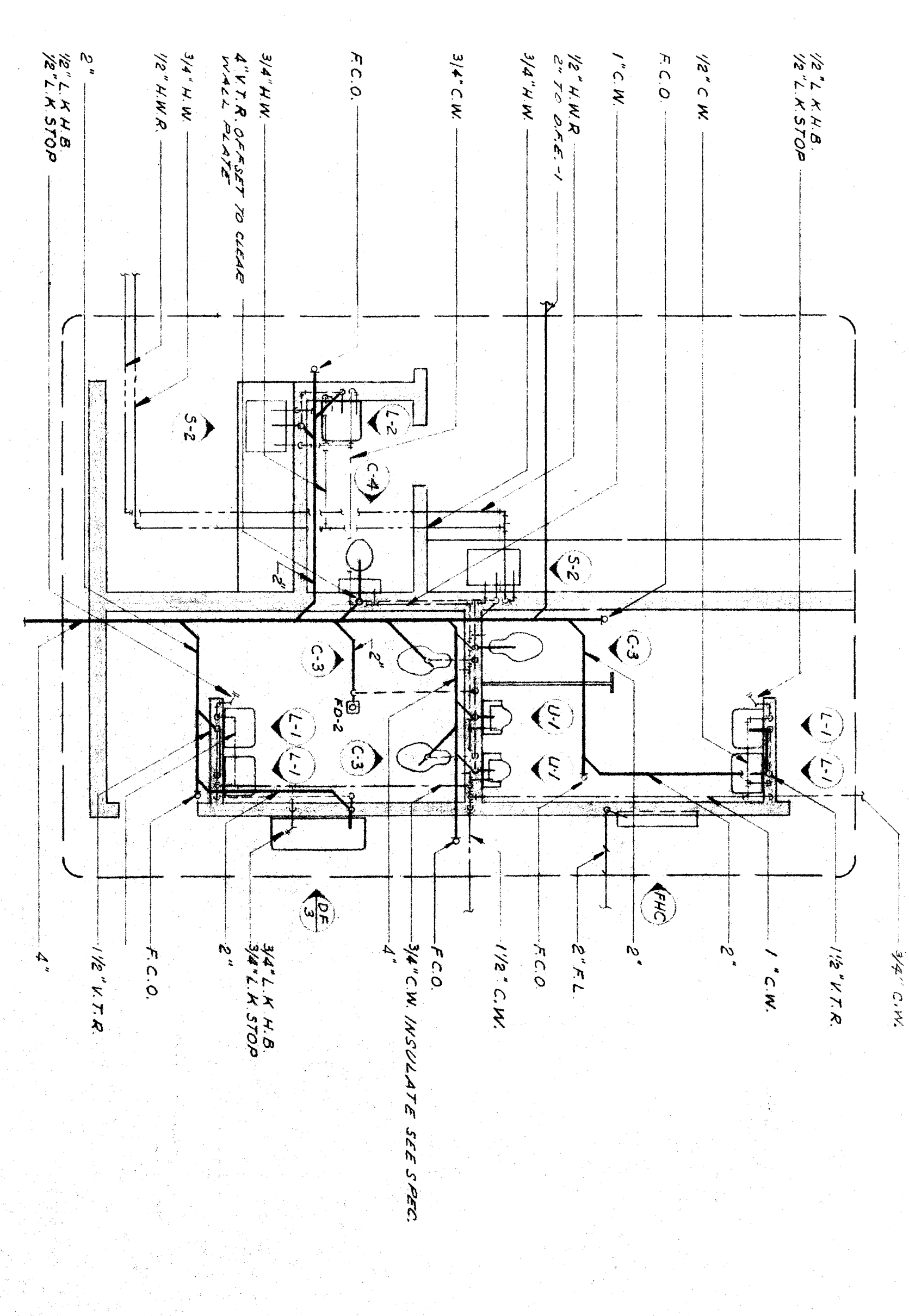

PLAN DETAIL B'-P2
SCALE: 1/4\"/>

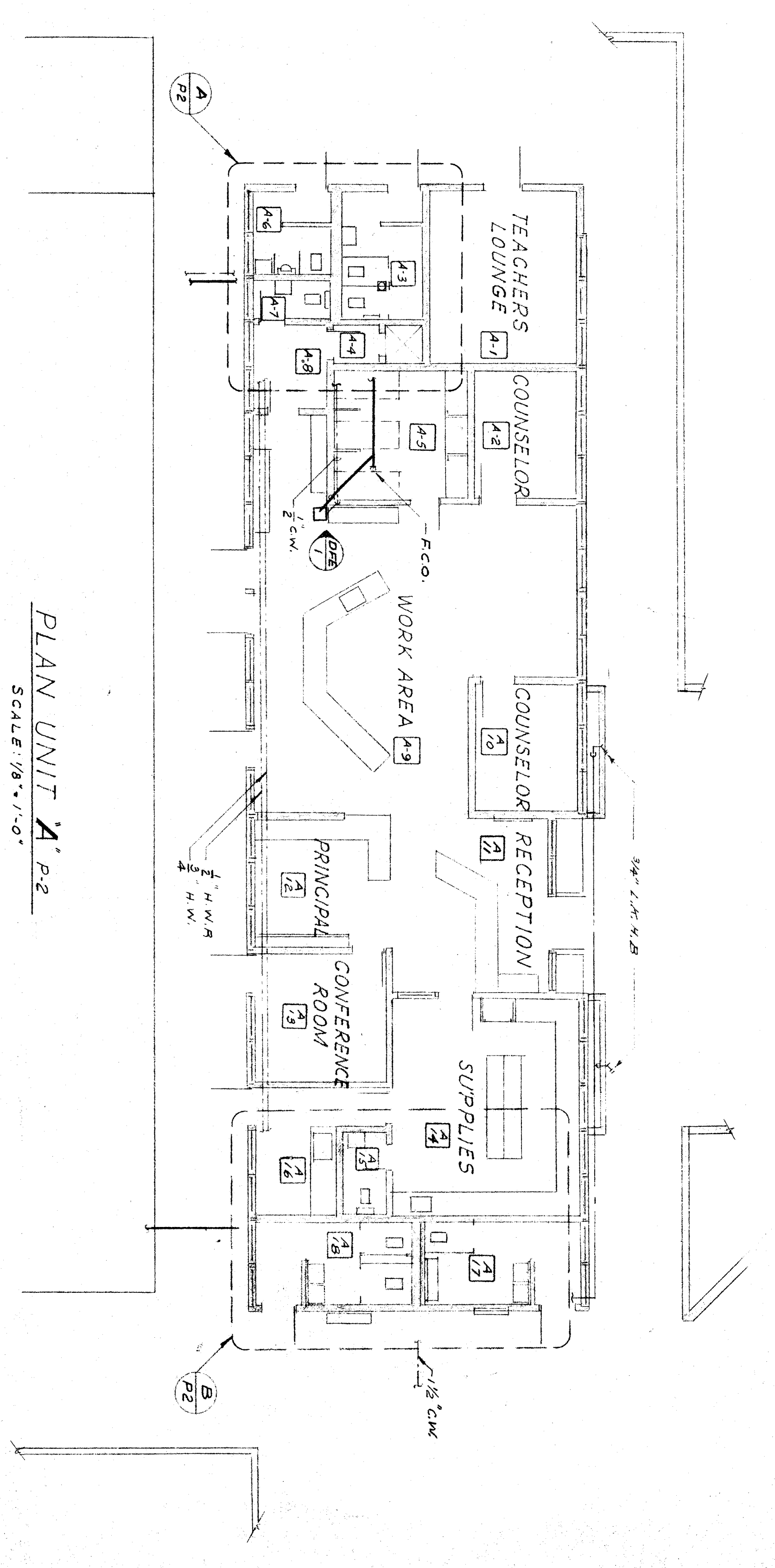

PLAN UNIT A'-P2
SCALE: 1/8\"/>

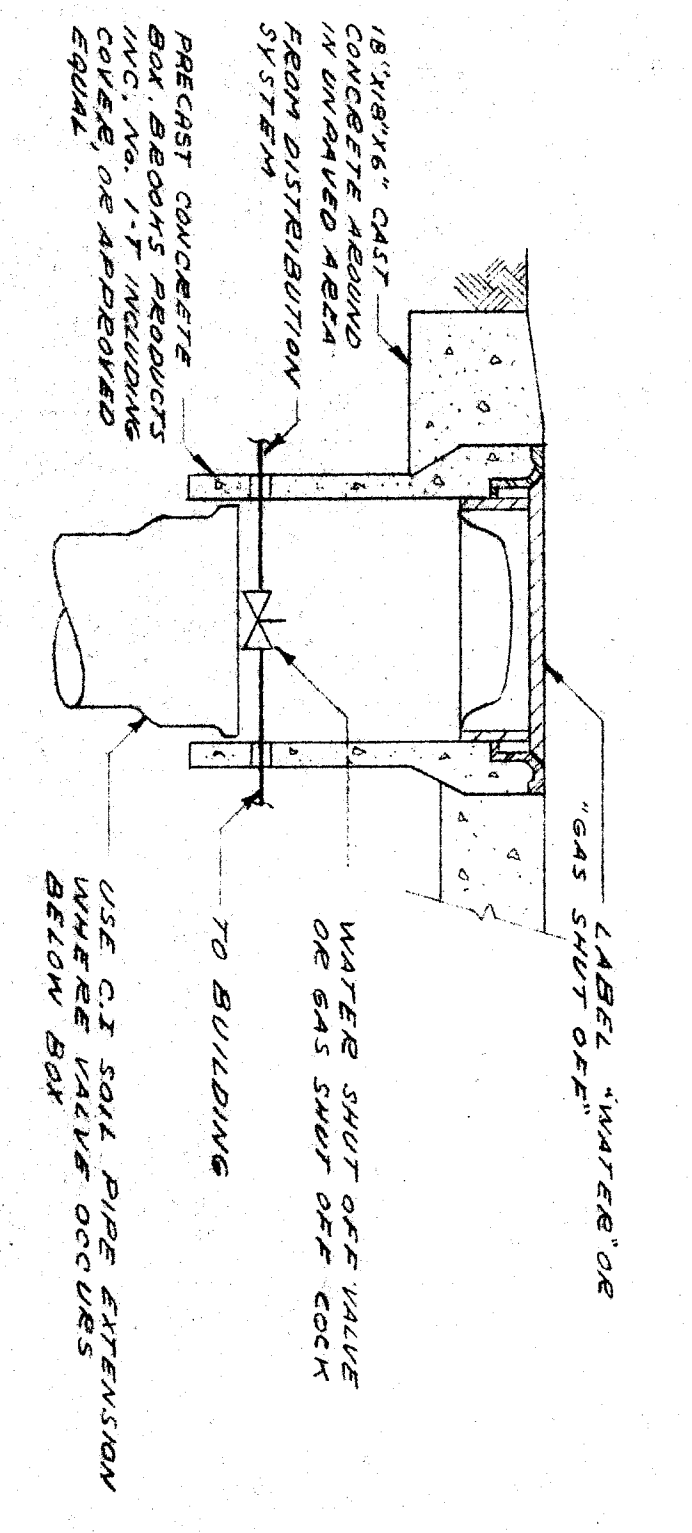

DETAIL C'-P2
WATER OR GAS SHUTOFF IN BOX
NO SCALE

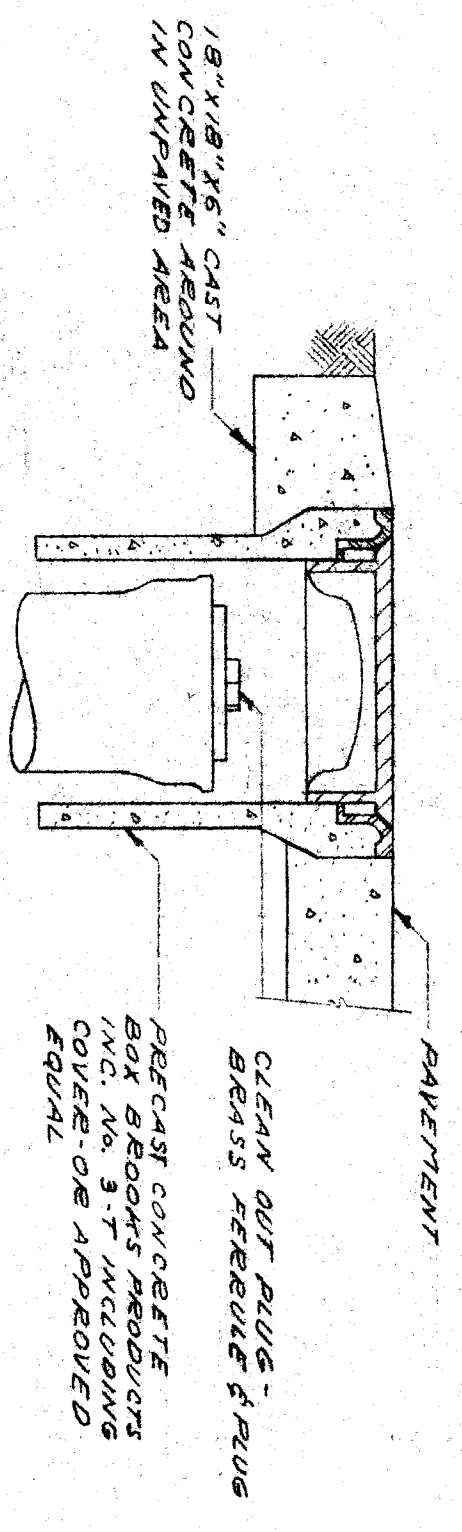

DETAIL D'-P2
SURFACE CLEANOUT IN BOX
NO SCALE

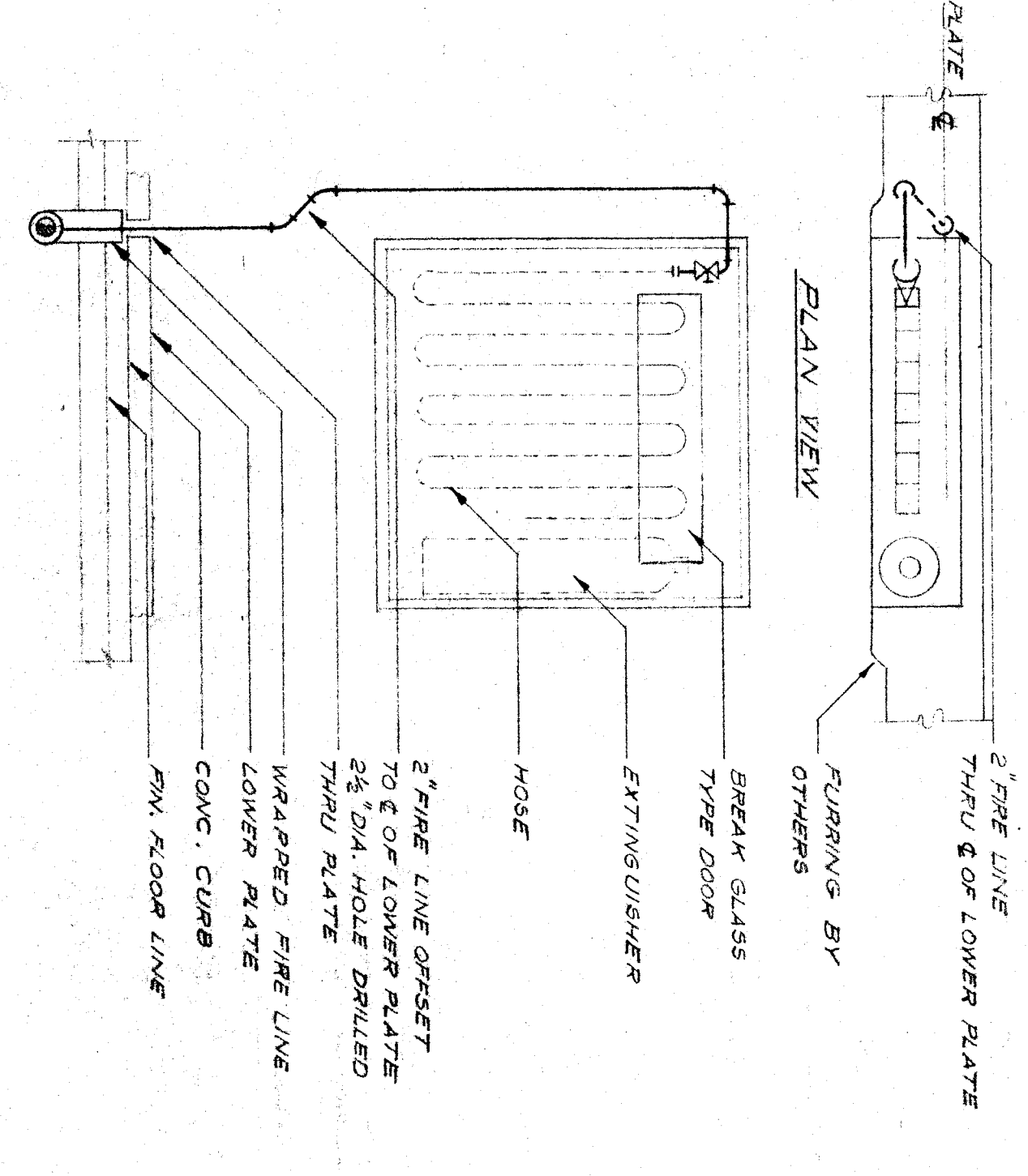

DETAIL
FIRE HOSE & EXTINGUISHER CABINET
NO SCALE

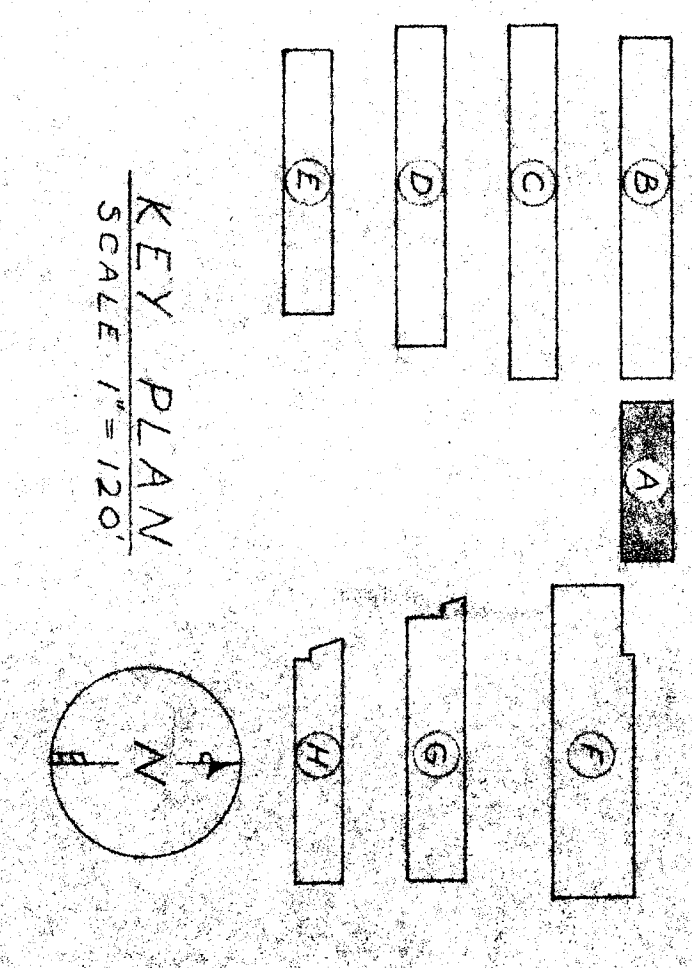

KEY PLAN
SCALE: 1\"/>

PROJECT NO. 20 DATE 8/1/57 126 69	ARCHITECT J. C. HARTILL 4908 BROADWAY OAKLAND 12, CALIF.	OFFICE OF SUPERINTENDENT OF SCHOOLS APPROVED DATE	STATE OF CALIFORNIA DEPARTMENT OF PUBLIC WORKS DIVISION OF ARCHITECTURE	PROJECT NO. 10110 DATE AUG 11 1957 APPROVED BOARD OF TRUSTEES	BAKERSFIELD CITY SCHOOLS 1600 K STREET BAKERSFIELD, CALIFORNIA BOARD OF TRUSTEES	APPROVED DATE	WASHINGTON JR. HIGH SCHOOL BAKERSFIELD CITY SCHOOL DISTRICT BAKERSFIELD CALIFORNIA	ARCHITECT ERNEST L. MCCOY 2811 H STREET BAKERSFIELD	ARCHITECT A. I. A. ARCHITECT PROJECT CHECKED 8/1/57 CHECKED BY P2	SHEET NO. P2 OF 5 SHEETS
--	---	---	---	--	---	------------------	--	--	--	--------------------------------