

DIMENSIONS FOR ACCESSIBILITY IN TOILET FACILITIES				
FIXTURE TYPE	ADULT (AGE 12 AND OVER) DIMENSION	ELEMENTARY DIMENSION	KINDERGARTEN & PRE-SCHOOL DIMENSION	REMARKS
A TOILET CENTERLINE FROM WALL	18"	15"	12"	FLUSH VALVE TO WIDE SIDE OF STALL TYP
B TOILET SEAT HEIGHT (TO TOP OF SEAT)	17"-19"	15"	10"-12"	
C GRAB BAR HEIGHT	33"	27"	20"-22" ABOVE SEAT *	36" GRAB BAR @ REAR OF TOILET (250 LB CAPACITY TYP) (ALLOWED @ 36" A.F.F. @ TANK TYPE TOILET) 42" GRAB BAR @ SIDE OF TOILET
D TOILET PAPER DISPENSER IN FRONT OF TOILET (TPD)	12" MAX.	6" MAX.	6" MAX. **	12" IN FRONT OF TOILET ROLL PAPER HOLDER WITHOUT STOPS
E NAPKIN DISPOSAL IN FRONT OF TOILET (SND)	12" MAX.	12" MAX.	N/A	24" IN FRONT OF TOILET (BY OWNER)
F DISPENSER OR MIRROR HEIGHT	40" MAX.	36" MAX.	32" MAX.	
G LAVATORY/SINK TOP HEIGHT	34" MAX.	29" MAX.	24" MAX.	WRAP DRAIN WATER IF HOT WATER OCCURS
H LAVATORY/SINK KNEE CLEARANCE	27" MIN.	24" MIN.	19" MIN.	
I URINAL LIP HEIGHT	17" MAX.	15" MAX.	13" MAX.	
J URINAL FLUSH HANDLE HEIGHT	44" MAX.	37" MAX.	32" MAX.	
K DRINKING FOUNTAIN BUBBLER HEIGHT	36" MAX.	32" MAX.	30" MAX.	
L DRINKING FOUNTAIN KNEE CLEARANCE	27" MIN.	24" MIN.	22" MIN.	
M RAMP/STAIR HANDRAIL HEIGHT	34"-38"	27"	22"	

* = ABOVE SEAT
 ** = DEVIATES FROM CODE REQUIREMENTS AND REQUIRES A WRITTEN FINDING OF UNREASONABLE HARDSHIP
 NOTE: 1. ALL ITEMS ON THIS SCHEDULE DO NOT NECESSARILY OCCUR IN THE PROJECT
 2. HEIGHTS NOTED ON INTERIOR ELEVATIONS SHALL GOVERN OVER THOSE SHOWN HERE.
 SCD = SEAT COVER DISPENSER TPD = TOILET PAPER DISPENSER
 PTD = PAPER TOWEL DISPENSER SND = SANITARY NAPKIN DISPOSAL (WHERE APPLICABLE)
 SD = SOAP DISPENSER (ALL TOILET ACCESSORIES ARE N.I.C.)
 THIS DIAGRAM ILLUSTRATES THE SPECIFIC REQUIREMENTS OF THESE REGULATIONS AND IS INTENDED ONLY AS AN AID FOR BUILDING AND CONSTRUCTION

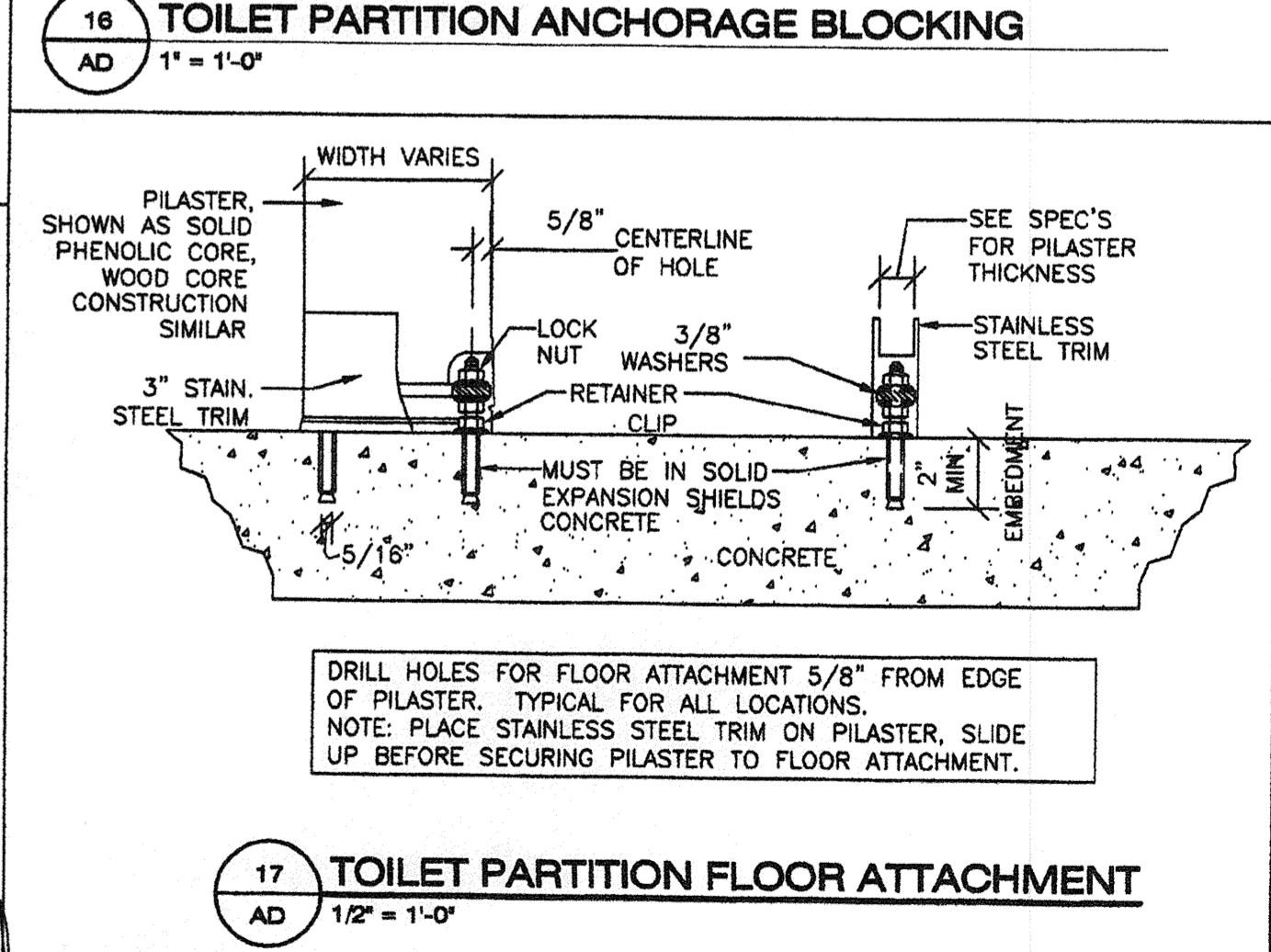
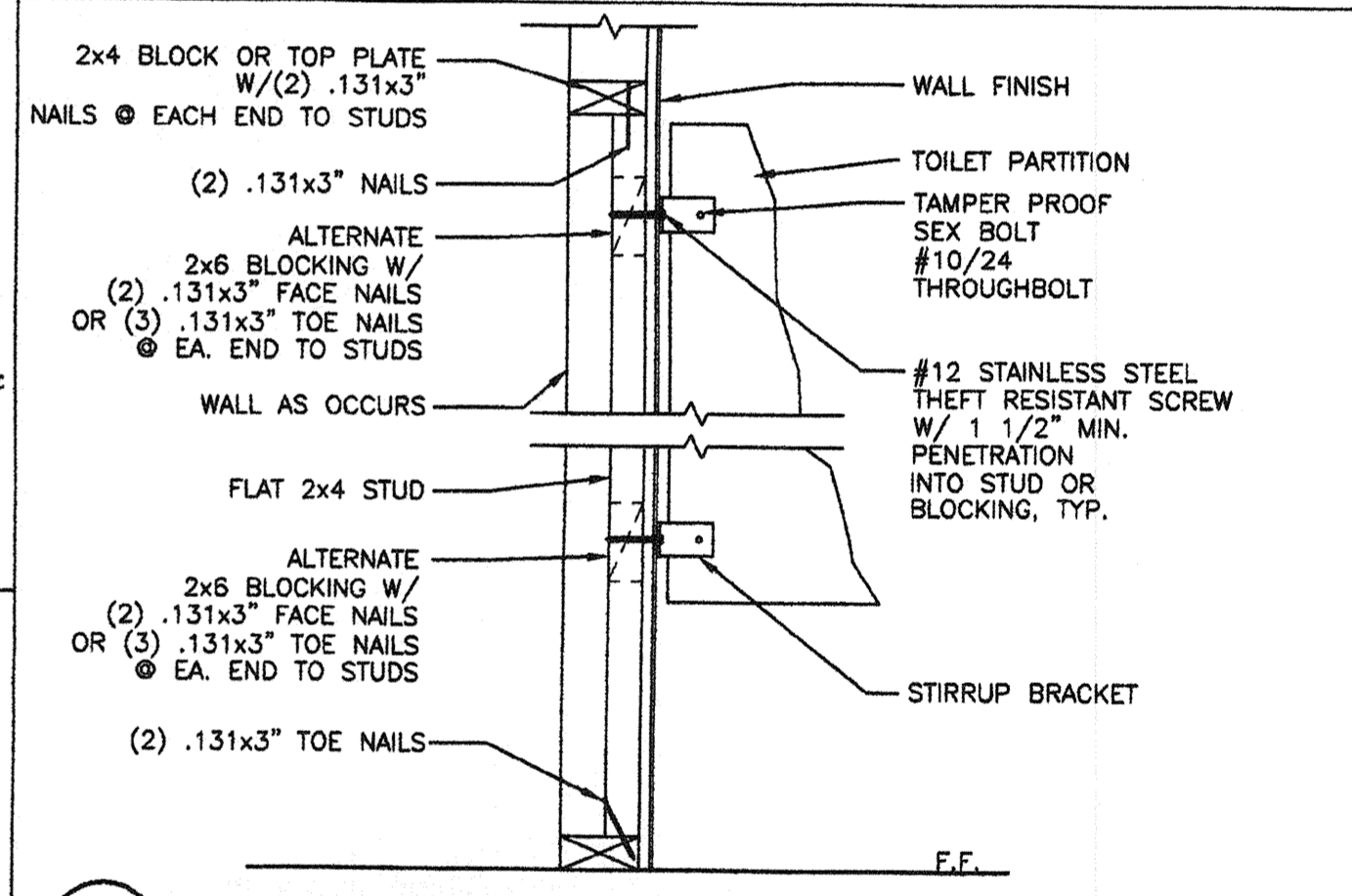
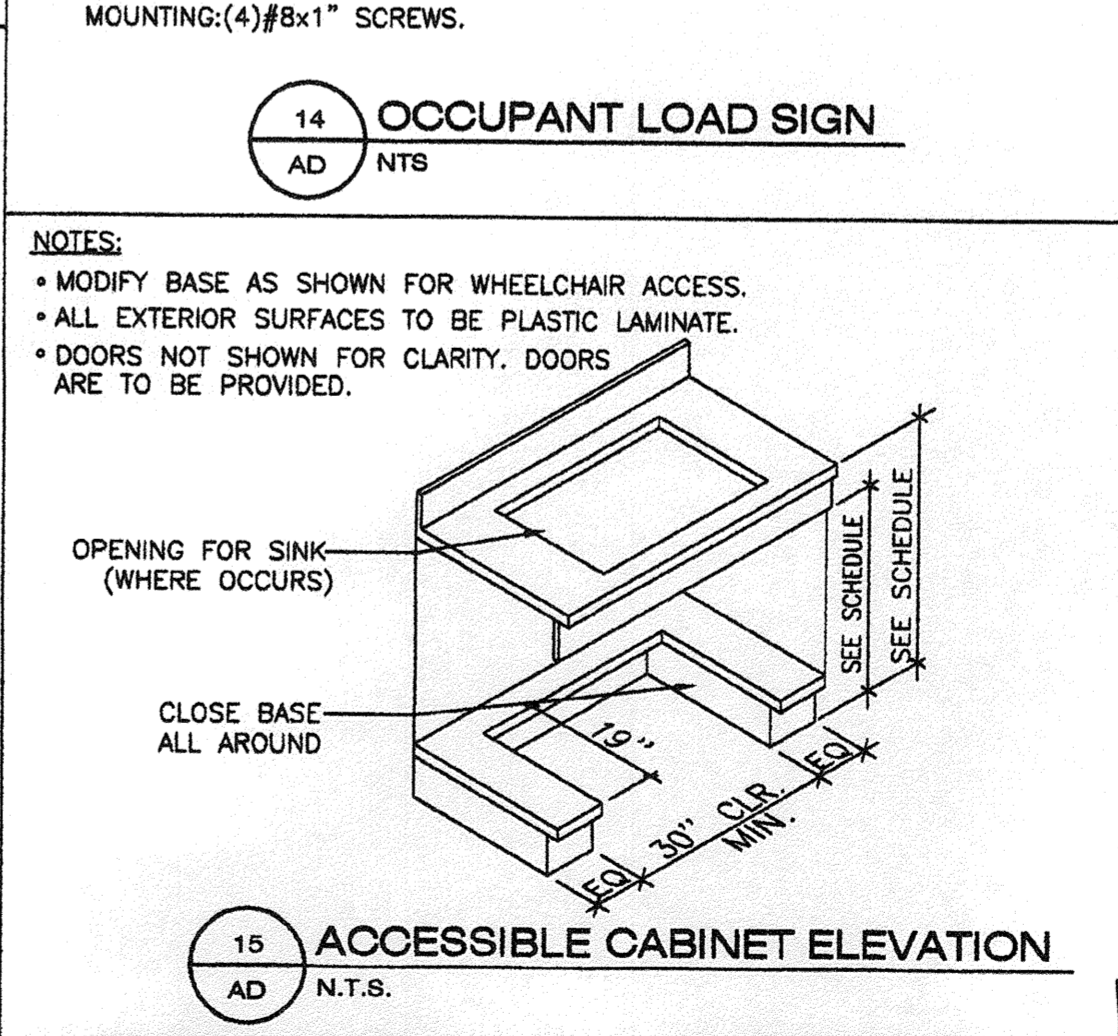
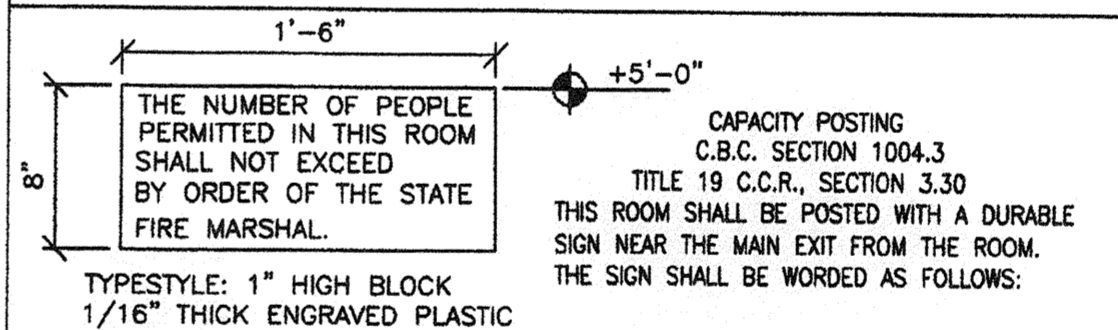
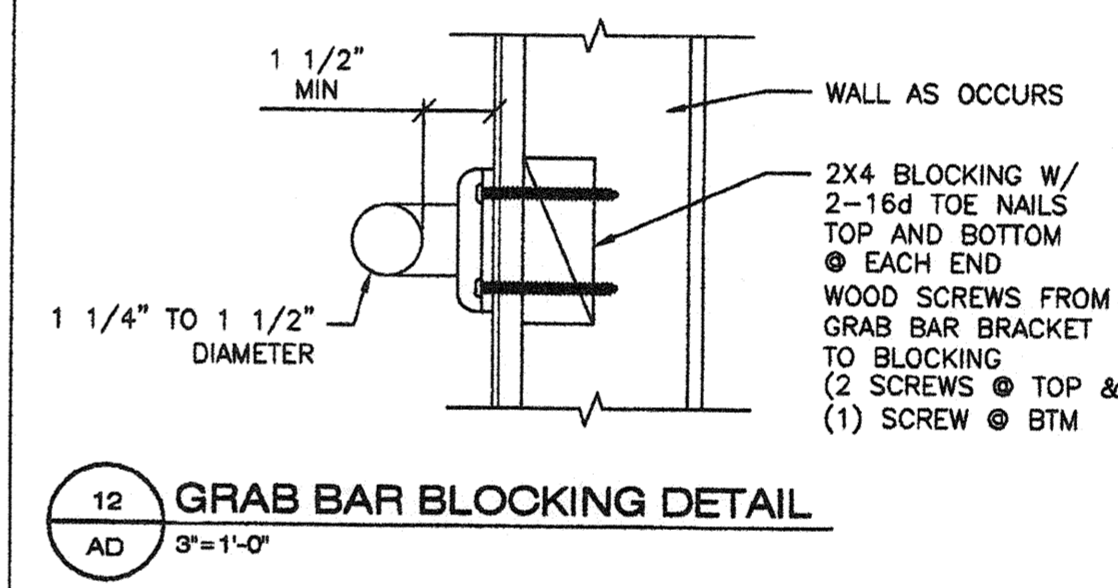
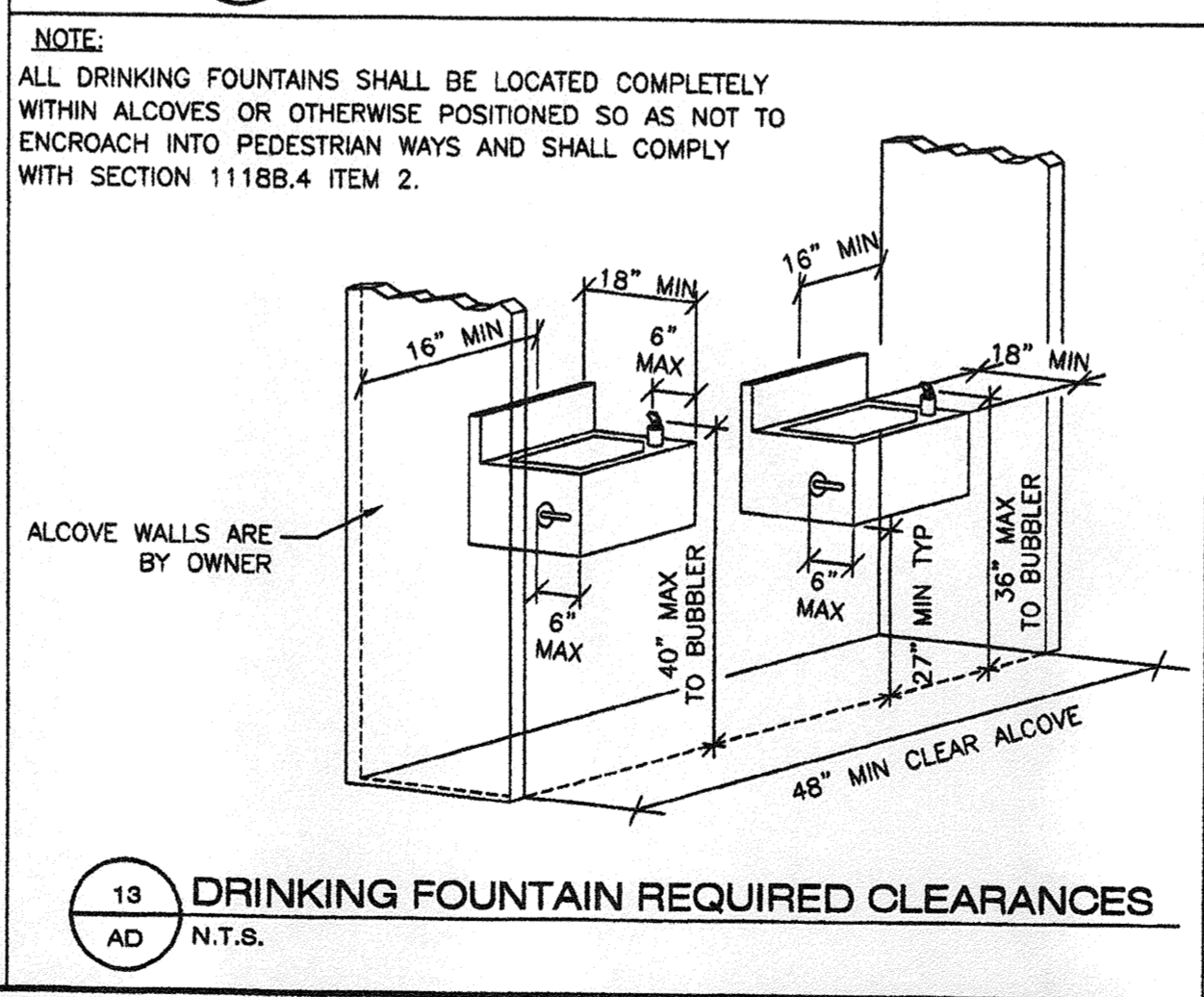
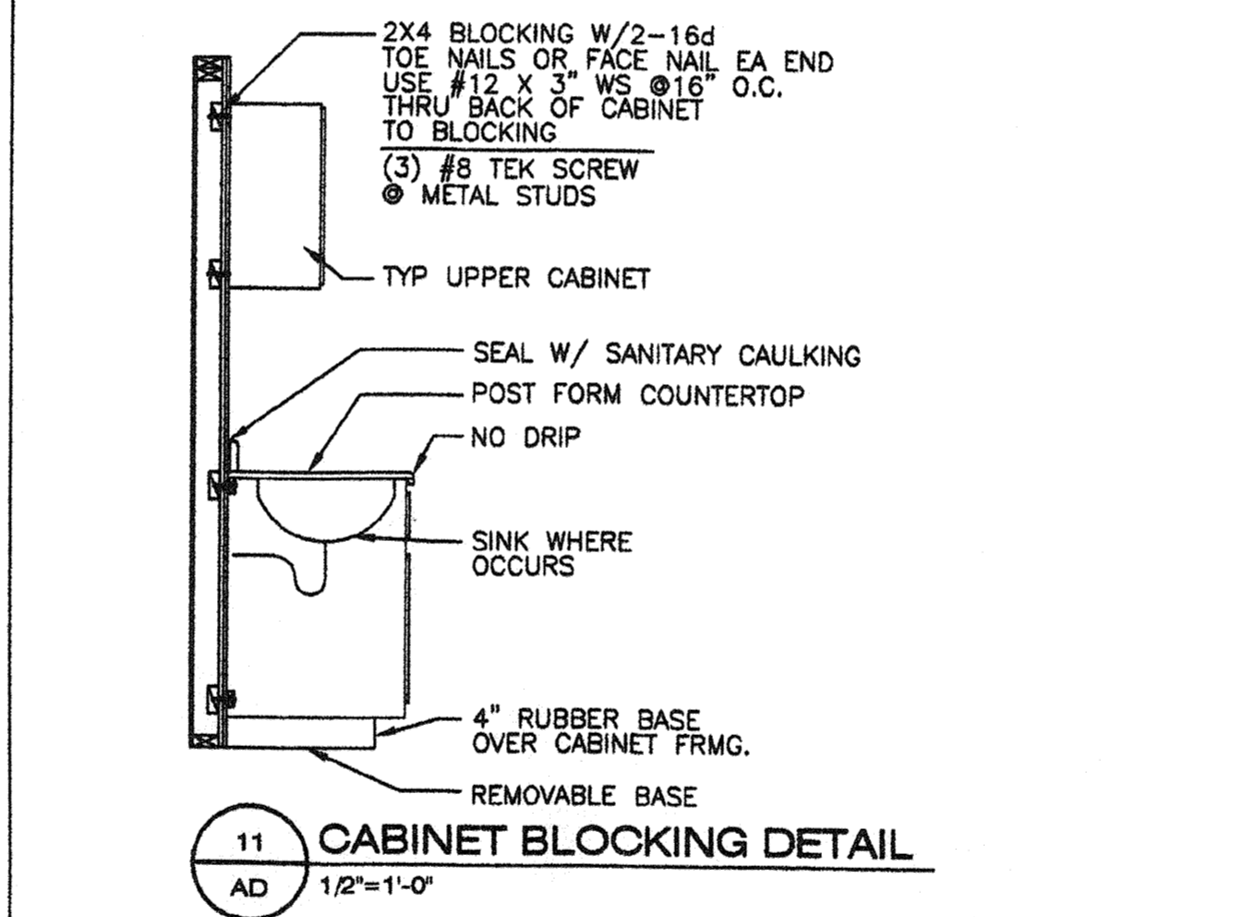
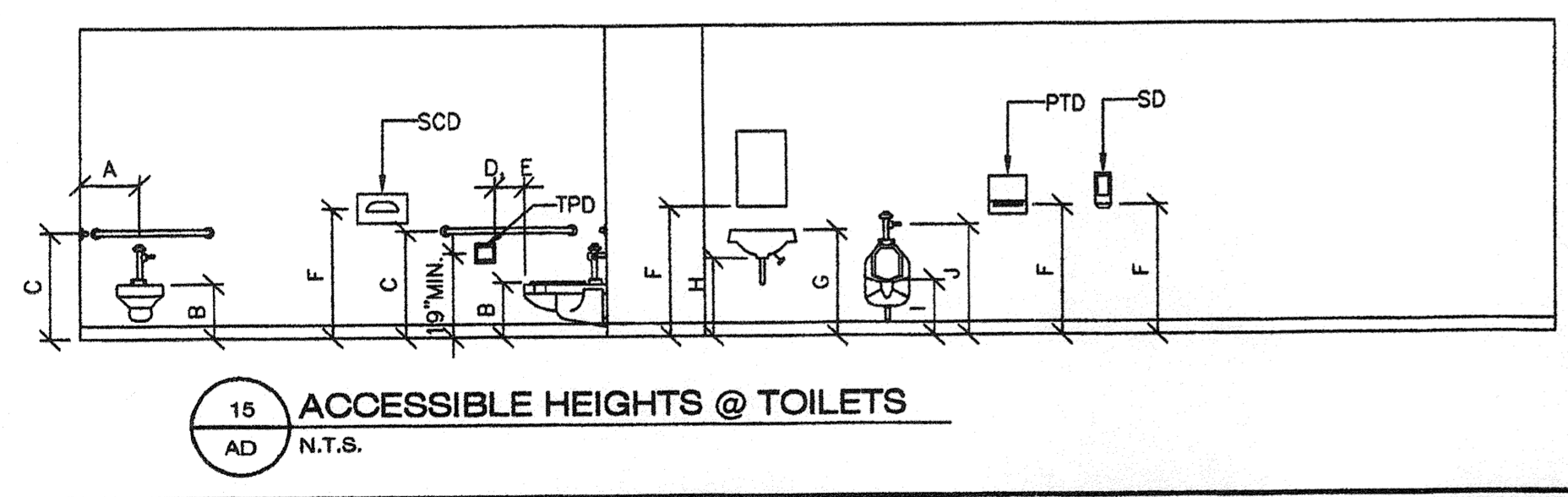

REVISIONS		
NO.	DATE	DESCRIPTION

DATE: 12/02/04
 SCALE: NOTED
 DRAWN BY: DM
 SERIAL NO.:

CUSTOMER:
 2:12 PITCHED ROOF 24' x 40' THRU 120' x 40' RELOCATABLE CLASSROOMS
 ACCESSIBLE DETAILS



APPROVALS:
 IDENTIFICATION STAMP
 DIV. OF THE STATE ARCHITECT
 112985
 DATE: SEP 24 2003

IDENTIFICATION STAMP
 DIV. OF THE STATE ARCHITECT
 OFFICE OF REGULATION SERVICES
 PC 02-109695
 AC: FLS CH SS
 DATE: 3/23/04

PROJECT NO.
 PC
 AD

GENERAL NOTES AND SPECIFICATIONS

SECTION 1A GENERAL REQUIREMENTS

1. GENERAL
 - A. THE REQUIREMENTS OF THE GENERAL CONDITIONS OF THE AGREEMENT AND THIS GENERAL REQUIREMENT APPLY TO THE SEVERAL TRADE SECTIONS WITH THE SAME FORCE AS THOUGH FULLY REPEATED IN EACH TRADE SECTION.
 - B. NAME BRANDS ARE INDICATED TO ESTABLISH A STANDARD OF QUALITY. ITEMS OF EQUAL OR BETTER QUALITY MAY BE SUBSTITUTED FOR THE LISTED BRAND NAMED PRODUCTS WITH THE WRITTEN APPROVAL OF D.S.A. AND THE ARCHITECT.
 - C. ALL WORK SHALL COMPLY WITH THE REQUIREMENTS OF TITLES 19 AND 24 CALIFORNIA CODE OF REGULATIONS 2007 C.B.C. NO CHANGES SHALL BE MADE FROM D.S.A. APPROVED DRAWINGS OR SPECIFICATIONS WITHOUT PRIOR WRITTEN APPROVAL OF D.S.A. AND THE ARCHITECT.
2. SCOPE OF WORK
 - A. THE WORK CONSISTS OF MANUFACTURING OFF-SITE IN A PLANT AND INSTALLING ON-SITE, MODULAR RELOCATABLE BUILDINGS AS DEFINED HEREIN AND SHOWN AND DETAILED ON DRAWINGS.
 - B. ALL REQUIREMENTS OF TITLES 24 OF THE STATE OF CALIFORNIA CODE OF REGULATIONS RELATING TO INSPECTIONS AND VERIFIED REPORTS SHALL BE COMPLIED WITH AND SHALL INCLUDE:
 1. GENERAL RESPONSIBLE CHARGE OF FIELD ADMINISTRATION BY THE ARCHITECT OF RECORD.
 2. INSPECTION IN-PLANT DURING THE COURSE OF CONSTRUCTION BY AN INSPECTOR APPROVED BY THE DIVISION OF THE STATE ARCHITECT AND THE DISTRICT ARCHITECT. THE INSPECTOR SHALL BE RESPONSIBLE FOR AND APPROVED TO INSPECT THE GENERAL CONSTRUCTION WELDING, MECHANICAL, AND ELECTRICAL WORK. COST OF THESE INSPECTIONS SHALL BE BORNE BY THE SCHOOL DISTRICTS.
 3. ON-SITE INSPECTION OF THE BUILDING INSTALLATION ELECTRICAL AND UTILITY INSTALLATION OR CONNECTIONS BY AN INSPECTOR APPROVED BY THE DIVISION OF THE STATE ARCHITECT AND THE DISTRICT ARCHITECT AND RETAINED BY THE SCHOOL DISTRICT.
 4. OTHER SPECIAL TESTS OR INSPECTIONS AS MAY BE REQUIRED BY THE DIVISION OF THE STATE ARCHITECT. ADDENDUMS SHALL BE SIGNED BY THE ARCHITECT & APPROVED BY D.S.A.
 5. CHANGE ORDERS SHALL BE SIGNED BY THE OWNER & ARCHITECT & APPROVED BY D.S.A.
 6. THE TESTING LAB SHALL BE IN THE EMPLOY OF THE OWNER.
 7. ALL CONTRACTORS SHALL VERIFY ALL WORK CONDITIONS, DIMENSIONS AND DETAILS AND REPORT ANY OR ALL OMISSIONS AND DISCREPANCIES TO THE DESIGNER/OWNER IMMEDIATELY BEFORE COMMENCING WORK.
 8. EACH CONTRACTOR TO BE RESPONSIBLE TO SEE THAT THEIR WORK CONFORMS TO ALL GOVERNMENTAL CODES WHETHER OR NOT SO STATED ON THE DRAWINGS.
 9. ALL MATERIALS AND WORKMANSHIP TO CONFORM TO THE LATEST REQUIREMENTS OF THE GOVERNING BUILDING CODES IN EFFECT AT TIME OF DSA APPLICATION.
 10. ALL MANUFACTURED ARTICLES, MATERIALS AND EQUIPMENT SHALL BE APPLIED, INSTALLED, CONNECTED AND ERECTED PER MANUFACTURER'S DIRECTIONS AND INSTRUCTIONS.
 11. SHOP DRAWINGS MAY BE REQUIRED. IF SO, THEY WILL BE ACCURATELY DRAWN TO A LARGE ENOUGH SCALE TO SHOW ALL PERTINENT FEATURES OF THE ITEM AND ITS CONNECTION TO RELATED WORK.
 12. THE MANUFACTURER OF BUILDING IS TO PLACE TWO PERMANENT METAL IDENTIFICATION LABEL ON EACH MODULE, MECHANICALLY FASTENED TO THE FRAME SEE "GENERAL DESIGN REQUIREMENTS", THIS PAGE.
FOR PROJECTS MANUFACTURED OFF-SITE, THE PLANT INSPECTOR IS TO INDICATE THE MANUFACTURER'S NAME AND SERIAL NUMBER OF EACH MODULE ON THE VERIFIED REPORT AND D.S.A. APP. NUMBER.
 13. ALL TESTS AND INSPECTIONS REQUIRED BY DSA SHALL BE COMPLIED WITH. ALL TESTS REQ. BY FIRE AND LIFE SAFETY REGULATIONS SHALL BE BY A NATIONALLY RECOGNIZED TESTING LABORATORY.

SECTION 2 FOUNDATION

1. ASSUMED ALLOWABLE SOIL BEARING: 1000 PSF FOR WOOD FOUNDATIONS, 1500 P.S.F. FOR CONCRETE FOUNDATIONS EMBEDDED 12" MIN BELOW GRADE.
 2. FOOTINGS SHALL BE LOCATED ON UNDISTURBED FIRM NATURAL SOIL, APPROVED COMPACTED FILL OR ON AN APPROVED PAVED SURFACE.
- NOTE: THE FOUNDATION SYSTEM PRESENTED HEREIN COMPLIES WITH INTERPRETATION OF REGULATIONS IN 16-1 ISSUED BY DIVISION OF THE STATE ARCHITECT FOR TEMPORARY BUILDINGS. THIS FOUNDATION SYSTEM IS NON-CONVENTIONAL AND THE STRUCTURAL ENGINEER TAKES NO RESPONSIBILITY FOR ITS CONSTRUCTION OR LONGEVITY.

WORK NOT INCLUDED:

- A. ALL ON-SITE OR OFF-SITE UTILITIES AND THE CONNECTION OF THEM TO THE BUILDING UNLESS INDICATED ON THE DRAWINGS.
- B. ALL LEVELING, GRADING OR OTHER SITE PREPARATION EXCEPT CONCRETE OR WOOD LEVELING STRIPS WHERE REQUIRED, UNLESS OTHERWISE INDICATED ON THE DRAWINGS.
- C. FIRE ALARM SYSTEM, PROGRAM BELL, PUBLIC ADDRESS SYSTEM, INTERCOM SYSTEM, TELEPHONE SYSTEM UNLESS OTHERWISE INDICATED ON THE DRAWINGS, OR MODIFIED BY CHANGE ORDER.
4. WHEELS AND HITCH SHALL REMAIN THE PROPERTY OF THE CONTRACTOR.
5. ACCESSIBILITY OF SITE
THE SCHOOL DISTRICT SHALL PROVIDE ACCESS TO THE SITE FOR THE INSTALLATION OF BUILDINGS. REMOVAL OF TREES SHRUBS, FENCING, SPRINKLERS ETC. NECESSARY FOR THE MOVE-IN OF BUILDINGS SHALL BE THE RESPONSIBILITY OF THE SCHOOL DISTRICT.

SECTION 5 STEEL

- A. GENERAL - ALL WORK SHALL CONFORM TO THE REQUIREMENTS OF AISC STANDARD SPECIFICATIONS, TITLE 24 OF CALIFORNIA CODE OF REGULATIONS AND THE AMERICAN IRON AND STEEL INSTITUTE SPECIFICATIONS FOR DESIGN OF STEEL STRUCTURAL MEMBERS. A COPY OF TITLE 24 SHALL BE KEPT AT THE JOBSITE AT ALL TIMES.
- B. WELDING - ALL WELDING DONE BY SHIELDED ELECTRIC-ARC OR FLUX CORED-ARC PROCESS COMPLYING WITH REQUIREMENTS OF THE "STRUCTURAL WELDING CODE" OF THE AMERICAN WELDING SOCIETY. WELDING DONE BY OPERATORS QUALIFIED BY TESTS ACCEPTABLE TO THE DIVISION OF THE STATE ARCHITECT. WELDING INSPECTION PER TITLE 24, PART 2, CCR, SECTION 1704A.3.1 WELDING ELECTRODE SHALL BE E70XX. ALL WELDS USED IN PRIMARY MEMBERS AND CONNECTIONS IN THE LATERAL FORCE-RESISTING SYSTEMS SHALL BE MADE WITH A FILLER METAL THAT HAS A MINIMUM CHARPY V-NOTCH TOUGHNESS OF 20FT-LBS AT ZERO DEGREES F, AS DETERMINED BY AWS CLASSIFICATION OR MANUFACTURER'S CERTIFICATIONS.
 1. STRUCTURAL STEEL SHALL CONFORM TO A.S.T.M. A-36
 2. PIPE COLUMNS SHALL CONFORM TO A.S.T.M. A-53 WITH SULFUR CONTENT NOT EXCEEDING 0.05%
 3. STEEL TUBING SHALL CONFORM TO A.S.T.M. A-500 GRADE B OR A.S.T.M. A579 GRADE 50 FOR GAUGE TUBING-TYP. U.N.O.
 4. STRUCTURAL WELDS ARE DESIGNED FOR FULL ALLOWABLE STRESS UNLESS OTHERWISE NOTED.
- C. ERECTION - STRUCTURAL STEEL ERECTED TRUE, STRAIGHT, PLUMB AND TO ITS DESIGNATED LOCATIONS. FIELD CONNECTIONS BOLTED OR WELDED AS INDICATED ON THE DRAWINGS.
- D. NAILS, BOLTS, SCREWS AND NUTS ETC.- FOR EXTERIOR WORK SHALL BE CADMIUM PLATED OR GALVANIZED.
 1. BOLTS FOR STRUCTURAL STEEL JOINTS SHALL CONFORM TO A.S.T.M. A-307 UNLESS OTHERWISE NOTED. ALL HOLES FOR MACHINE AND CARRIAGE BOLTS THROUGH STEEL TO BE DRILLED, OR TORCH PILOT HOLE AND REAM MIN. 1/16" TO BOLT SIZE. NELSON STUDS (WELDED TO STEEL) MAY BE SUBSTITUTED FOR BOLTS SAME LENGTH AND DIAMETER.
- E. HANDRAILS - FABRICATED, AS DETAILED, WELDS GROUND SMOOTH.
- F. SHOP PAINT
 1. EXPOSED STEEL COATED WITH ONE SHOP COAT OF RED OXIDE PRIMER.
 2. NON-EXPOSED STEEL COATED WITH ONE SHOP COAT OF RED OXIDE PRIMER.
 3. ALL SURFACES THOROUGHLY CLEANED BY EFFECTIVE MEANS PRIOR TO APPLICATION OF SHOP COATS.
- G. TESTS
 1. PROVIDE MILL CERTIFICATES OR TEST ALL STEEL MEMBERS PER T-24 PART 2, CCR SECTION 2212A.1

SECTION 6A CARPENTRY

1. SCOPE OF WORK
CONTRACTOR SHALL PROVIDE ALL LABOR, MATERIALS AND SERVICES TO INSTALL CARPENTRY
2. MATERIALS
LUMBER GRADE MARKED IN ACCORDANCE WITH "STANDARD GRADING AND DRESSING RULE NO. 17" OF WEST COAST LUMBER INSPECTION BUREAU, OR "GRADING RULES FOR LUMBER, 3RD EDITION OF WESTERN WOOD PRODUCTS ASSOCIATION OR W.C.L.I.B. PLYWOOD GRADE MARKED IN ACCORDANCE WITH PRODUCT STANDARD PS 1-95 FOR SOFTWOOD PLYWOOD, OF AMERICAN PLYWOOD ASSOCIATION. EACH SHEET SHALL BEAR THE STAMP OF APA, PITTSBURGH TESTING, OR TECO.
- A. JOISTS, PLATES, STUDS-DOUGLAS FIR OR HEM FIR #2 OR BETTER U.N.O. NOTE: MSR 1650 E1.5 MAY BE SUBSTITUTED FOR #2 GRADE IF IT MEETS THE STRUCTURAL REQUIREMENTS FOR FLOOR AND ROOF MEMBERS.
- B. H.F. HEADERS, POSTS AND TIMBERS-DOUGLAS FIR S4S #1
- C. BLOCKING - DOUG FIR #3, OR HEM FIR #3, OR STD. & BET.
- D. SILLS AND LUMBER & SHIM PLATES IN CONTACT WITH CONCRETE, MASONRY OR EARTH, DOUG FIR OR HEM FIR #2 OR BETTER PRESSURE TREATED IN ACCORDANCE WITH CBC 2304.11.2 EACH PIECE SHALL BEAR ANWPB STAMP, ANWPB STANDARD U1 & T1 GROUND CONTACT, D.F.O.R. H.F. #2 ABOVE GROUND.
- E. MOISTURE BARRIER - KRAFT WATERPROOF BUILDING PAPER, OR 15 LB. FELT, PER 2007 CBC 17-1 FOR KRAFT, 32-1 FOR FELT.
- F. STUDS - S4S DOUG FIR #2 OR #2 HEM FIR. MAXIMUM MOISTURE CONTENT OF 19% AT TIME OF INSTALLATION.
- G. FASTENERS - NAILS SHALL BE CORROSION RESISTANT PER C.B.C. 2304.9.1.1 COMMON NAILS FOR EXT. SIDING & FNDN. ONLY.
- H. BUILDING TRIM - 2X RESAWN SELECT D.F., H.F. OR CEDAR
- J. DOOR/WINDOW TRIM - 1X4 RESAWN D.F., H.F., OR CEDAR.
- K. FRAMING CONNECTORS SHALL BE FROM SIMPSON CATALOG LATEST ED.
- M. FIRE BLOCKS SHALL CONFORM TO CBC SECTION 717
- N. ALL NAILS SHALL BE COMMON NAILS UNLESS OTHERWISE NOTED.
- O. FOUNDATION LUMBER: ALL CUT ENDS AND HOLES IN PRESSURE TREATED LUMBER SHALL BE TREATED WITH "CUPRINOL".
3. WORKMANSHIP
 - A. FRAMING - SECURELY NAILED, BRIDGED AND BLOCKED TO FORM RIGID STRUCTURE. WORK CUT, FITTED AND ASSEMBLED LEVEL PLUMB AND TRUE TO LINE. TRIM IN AS LONG LENGTHS AS POSSIBLE WITH ALL STANDING TRIM IN ONE PIECE. TRIM SEALED AT ALL EDGES.
 - B. NAILING - IN ACCORDANCE WITH TITLE 24, CALIFORNIA BUILDING CODE, TABLE 2304.9.1
 - C. EXTERIOR WALLS - FACTORY FABRICATED. CAULKING PROVIDED BETWEEN PERIMETER OF WALL AND STRUCTURAL MEMBERS PROVIDING WEATHER-PROOF AND WATER-TIGHT SEAL. NECESSARY CLOSERS, SEALS, AND FLASHINGS PLACED AT TOP AND BASE SUPPORT OF PANELS AND AROUND OPENINGS.
 - D. NAILS INTO P.T. LUMBER TO BE HOT DIPPED GALVANIZED.

- E. MACHINE APPLIED NAILING: USE OF MACHINE NAILING IS SUBJECT TO A SATISFACTORY JOBSITE DEMONSTRATION FOR EACH PROJECT AND THE APPROVAL BY THE PROJECT ARCHITECT OR STRUCTURAL ENGINEER AND THE DIVISION OF THE STATE ARCHITECT. THE APPROVAL IS SUBJECT TO CONTINUED SATISFACTORY PERFORMANCE.
MACHINE NAILING WILL NOT BE APPROVED IN 5/16" PLYWOOD. IF NAILHEADS PENETRATE THE OUTER PLY MORE THAN WOULD BE NORMAL FOR A HAND HAMMER OR IF MINIMUM ALLOWABLE EDGE DISTANCES ARE NOT MAINTAINED THE PERFORMANCE WILL BE DEEMED UNSATISFACTORY.
- F. MOISTURE BARRIER - APPLIED TO STUDS WEATHER-BOARD FASHION, HORIZONTAL JOINTS LAPPED MIN 6" INCLUDING BUILDING CORNERS. SHEATHING APPLIED OVER MOISTURE BARRIER.
- G. TRIM SEALED AT ALL EDGES. SEALANT PAINTED TO MATCH TRIM OR SIDING UNLESS TRANSPARENT TYPE.

SECTION 7B SHEET METAL

1. SCOPE OF WORK
CONTRACTOR SHALL PROVIDE ALL LABOR, MATERIALS AND SERVICES TO INSTALL INDICATED SHEET METAL.
2. MATERIALS
 - A. SHEET METAL - STEEL SHEETS HOT DIP GALVANIZED WITH 1.25 OZ. PER SQUARE FOOT ZINC COATING CONFORMING TO ASTM A526. MINIMUM 26 GA UNLESS OTHERWISE NOTED ON THE DRAWINGS.
 - B. SOLDER - OF STAND. GRADE "A" OF EQUAL PARTS ARD BRAND LEAD AND TIN ASTM B32.
 - C. FLUX - ZINC SATURATED MURIATIC ACID.
 - D. GUTTERS: 26 GA. G-90 GALV. STEEL.
 - E. DOWNSPOUTS: 2"x3" CONVOLUTED 30 GA. G-90 GALV. STEEL.
 - F. GUTTER ENDCAPS: 26 GA. G-90 GALV. STEEL.
 - G. GUTTER CLIPS: 18 GA. G-90 GALV. STEEL.
3. WORKMANSHIP
SHEET METAL ACCURATELY FORMED TO DIMENSIONS AND SHAPES DETAILED WITH TRUE STRAIGHT LINES. CORNERS AND ANGLES. FLASHING INSTALLED IN LONGEST LENGTHS POSSIBLE. EXTERIOR WORK FORMED, FABRICATED AND INSTALLED SO THAT IT ADEQUATELY PROVIDES FOR EXPANSION AND CONTRACTION IN THE COMPLETED WORK AND FINISHES WATER AND WEATHER TIGHT. ALUMINUM SHALL BE SEPARATED FROM FERROUS METAL BY POLYETHYLENE TAPE OR FLOOR COAT OF ASPHALTIC PAINT.

SECTION 7C METAL ROOFING

1. SCOPE OF WORK
CONTRACTOR SHALL PROVIDE ALL LABOR, MATERIALS AND SERVICES TO INSTALL METAL ROOFING. TEST RESULTS SHOWING THE ROOFING SYSTEM WILL WITHSTAND THE UPLIFT OF A 85 MPH WIND SHALL BE SUBMITTED WITH THE PLANS AND SPECIFICATIONS.
2. MATERIALS
 - A. ROOFING - 1 1/4" INCH STANDING SEAM MIN 26-GAUGE G-90 GALV. INTERLOCKING (UNPENETRATED) SHEET STL PANELS (G90).
 - B. ALTERNATE: ROOFING - 3 INCH STANDING SEAM MIN 20-GAUGE G-90 GALV. INTERLOCKING (UNPENETRATED) SHEET STL PANELS (G90).
 - C. ROOFING: CLASS B FIRE RATING

SECTION 7J SEALANT

1. SCOPE OF WORK
CONTRACTOR SHALL PROVIDE ALL LABOR, MATERIAL AND SERVICES TO SEAL BUILDINGS.
2. MATERIALS
VULKEM SEALANT, POLYURETHANE, MANUFACTURED BY MAMECO INTERNATIONAL FOR ROOFS, "GEOCEL" SILICONIZED CAULK, GE, DUPONT, EAGLESEAL OR DAP FOR ALL OTHER APPLICATIONS, OR EQUAL.
3. WORKMANSHIP
SEALANT APPLIED TO DRY CLEAN SURFACES, WHEREVER INDICATED ON DETAILS AND AS NEEDED TO MAKE BUILDING WATERTIGHT IN ACCORDANCE WITH MANUFACTURER'S SPECIFICATIONS.

SECTION 8 CONCRETE

1. CONCRETE CONSTRUCTION SHALL CONFORM TO ACI 318-05
2. THE MINIMUM 28 DAY STRENGTH AND TYPE OF CONCRETE SHALL BE AS FOLLOWS:
SLABS ON GRADE & FOUNDATIONS 2500 PSI (150 PCF)
CONCRETE OVER METAL DECK 3000 PSI (110 PCF) OR (150 PCF)
3. REINFORCING SHALL CONFORM TO ASTM A615-GR40 UNO.
4. CONCRETE COVERAGE SHALL BE AS FOLLOWS, UON ON DRAWINGS:
CONCRETE DEPOSITED DIRECTLY AGAINST GROUND (EXCEPT SLABS)3"
CONCRETE EXPOSED TO GROUND BUT PLACED IN FORMS.....2"
SLABS (ON GROUND).....POSITION IN "CENTER OF SLAB"
5. ALL BARS SHALL HAVE A CLASS B MINIMUM SPLICE LAP UON.
6. NOTIFY THE STRUCTURAL ENGINEER PRIOR TO PLACING CONCRETE.

SECTION 8A EXTERIOR PLASTER

- LATHING AND PLASTERING MATERIALS AND ACCESSORIES SHALL BE MARKED BY THE MANUFACTURER'S DESIGNATION TO INDICATE COMPLIANCE WITH THE APPROPRIATE STANDARDS REFERENCED IN THIS SECTION AND STORED IN SUCH A MANNER TO PROTECT THEM FROM THE WEATHER. PER 2507.1
- LATHING AND PLASTERING MATERIALS SHALL CONFORM TO THE STANDARDS LISTED IN TABLE 2507.2 AND CHAPTER 35 AND, WHERE REQUIRED FOR FIRE PROTECTION, SHALL ALSO CONFORM TO THE PROVISIONS OF CHAPTER 7. PER 2507.2
- GYPSUM BOARD AND GYPSUM PLASTER CONSTRUCTION SHALL BE OF THE MATERIALS LISTED IN TABLES 2506.2 AND 2507.2. THESE MATERIALS SHALL BE ASSEMBLED AND INSTALLED IN COMPLIANCE WITH THE APPROPRIATE STANDARDS LISTED IN TABLES 2508.1 AND 2511.1, AND CHAPTER 35 PER 2508.1 PROVIDE 2 LAYERS OF GRADE D PAPER PER CBC SECTION 2510.6
- 2510.6 WATER-RESISTIVE BARRIERS. WATER-RESISTIVE BARRIERS SHALL BE INSTALLED AS REQUIRED IN SECTION 1404.2 AND, WHERE APPLIED OVER WOOD-BASED SHEATHING, SHALL INCLUDE A WATER-RESISTIVE VAPOR-PERMEABLE BARRIER WITH A PERFORMANCE AT LEAST EQUIVALENT TO TWO LAYERS OF GRADE D PAPER.
- EXCEPTION: WHERE THE WATER-RESISTIVE BARRIER THAT IS APPLIED OVER WOOD-BASED SHEATHING HAS A WATER RESISTANCE EQUAL TO OR GREATER THAN THAT 60-MINUTE GRADE D PAPER AND IS SEPARATED FROM THE STUCCO BY AN INTERVENING, SUBSTANTIALLY NONWATER-ABSORBING LAYER OR DRAINAGE SPACE.

1. GENERAL NOTES
PLASTERING WITH CEMENT PLASTER SHALL NOT BE LESS THAN THREE COATS WHEN APPLIED OVER METAL LATH OR WIRE FABRIC LATH AND SHALL NOT BE LESS THAN TWO COATS WHEN APPLIED OVER MASONRY CONCRETE OR GYPSUM BACKING AS SPECIFIED IN SECTION 2510.5
- A. THE FIRST COAT SHALL BE APPLIED WITH SUFFICIENT MATERIAL AND PRESSURE TO FILL SOLIDLY ALL OPENINGS IN THE LATH. THE SURFACE SHALL BE SCORED HORIZONTALLY SUFFICIENTLY ROUGH TO PROVIDE ADEQUATE BOND TO RECEIVE THE SECOND COAT.
- B. THE SECOND COAT SHALL BE BROUGHT OUT TO PROPER THICKNESS, RODDED AND FLOATED SUFFICIENTLY ROUGH TO PROVIDE ADEQUATE BOND FOR THE FINISH COAT. THE SECOND COAT SHALL HAVE NO VARIATION GREATER TO FINISH 1/4 INCH (6.4 mm) IN ANY DIRECTION UNDER 5-FOOT STRAIGHT EDGE.
- C. THE FINISH COATS SHALL BE APPLIED OVER BASE COATS THAT HAVE BEEN IN PLACE FOR THE TIME PERIODS SET FORTH IN ASTM C 926 THE THIRD OR FINISH COAT SHALL BE APPLIED WITH SUFFICIENT MATERIAL AND PRESSURE TO BOND TO AND TO COVER THE BROWN COAT AND SHALL BE OF SUFFICIENT THICKNESS TO CONCEAL THE BROWN COAT.

SECTION 8B HOLLOW METAL DOORS AND FRAMES

1. SCOPE OF WORK
CONTRACTOR SHALL PROVIDE ALL LABOR, MATERIALS AND SERVICES TO INSTALL HOLLOW METAL DOORS AND FRAMES.
2. MATERIALS
 - A. DOORS - INSULATED TYPE I FULL FLUSH, MANUFACTURED BY AMWELD MANUFACTURING COMPANY, 18 GA. 1 3/4" THICK PER CS242 MIN. REINFORCE FOR HARDWARE-BOTH FACES FOR CLOSER, SOUND DEADEN INTERIOR.
 - B. FRAMES - 16 GA COLD ROLLED, 2" FACES, CS242 MIN. 3 ANCHORS PER JAMB + ADJUSTABLE FLOOR ANCHOR EACH JAMB REINFORCE FOR HARDWARE. PROVIDE STRIKE BOX, PROVIDE SOUND DEADENING: 1/8" UNDERCOATING OR INSULATING FILL.
3. WORKMANSHIP
ALL WORK FABRICATED IN SHOP TO REQUIRED PROFILES BY FORMING AND WELDING, WITH ARISES AND EDGES STRAIGHT, SHARP FIT FABRICATED ACCURATELY WITH SQUARE CORNERS, HAIRLINE JOINTS AND SURFACES FREE FROM WARP, WAVE, BUCKLE OR OTHER DEFECTS AFTER FABRICATION, DOORS AND FRAMES CLEANED THOROUGHLY, ALL WELDS GROUND SMOOTH AND GIVEN PRIME COAT.

SECTION 9E PAINTING

1. SCOPE OF WORK
CONTRACTOR SHALL PROVIDE ALL LABOR, MATERIALS AND SERVICES TO PAINT BUILDING. ALL EXPOSED SURFACES OF BUILDING AND RAMPS SHALL BE PAINTED EXCEPT ALUMINUM WINDOW FRAMES, THRESHOLDS, AND ROOFING.
2. MATERIALS
 - A. FOR EXTERIOR WOOD:

REF. BRAND	DUNN EDWARDS	KELLY MOORE	SHERWIN WILLIAMS	SINCLAIR
PRIMER	42-9M	1240	Y24W20	289-N
FINISH	QD-60-XX	1240-XXX	B54WZ102	GE2-NXX
 - B. FOR INTERIOR TRIM

REF. BRAND	DUNN EDWARDS	KELLY MOORE	SHERWIN WILLIAMS	SINCLAIR
FINISH	W450-XX	1650-XXX	A26W11	40XX
 - C. FOR METAL

REF. BRAND	DUNN EDWARDS	KELLY MOORE	SHERWIN WILLIAMS	SINCLAIR
PRIMER	43-4	1710	B50NZ6	15N
FINISH	10-XX	1700-XXX	B54WZ102	GE2-NXX
3. WORKMANSHIP
ALL EXPOSED SURFACES SHALL BE PAINTED EXCEPT ALUMINUM WINDOW FRAMES AND THRESHOLDS. MATERIAL SHALL BE OF THE GRADE SPECIFIED OR EQUAL.
 - A. EXTERIOR - WOOD SIDING, TRIM AND SKIRTING FLAT OR SEMI-GLOSS LATEX - APPLY ONE COAT OF PRIME AND AT LEAST ONE FINISH COAT. PRIME COAT SHALL BE BRUSHED ON OR SPRAYED AND BACK BRUSHED INTO ALL GROOVES IN THE SIDING. IF NECESSARY, IN THE OPINION OF THE INSPECTOR, AN EXTRA COAT SHALL BE APPLIED TO ALL GROOVES SO THAT THE FINISH COAT WILL HAVE A UNIFORM APPEARANCE. ALLOW PRIME COAT TO DRY ACCORDING TO MANUFACTURER'S RECOMMENDATION. PRIME AND FINISH COATS SHALL BE COMPATIBLE AND MANUFACTURED BY THE SAME COMPANY.
 - B. INTERIOR TRIM - TRIM NOT PRECOATED SHALL BE PAINTED WITH TWO COATS OF SEMI-GLOSS LATEX OVER PRIMER.
 - C. INTERIOR HARDWOOD CABINETS - TWO COATS LOW LUSTER POLYURETHANE FINISH. APPLY FIRST COAT THINNED WITH ONE QUART MINERAL SPIRITS PER GALLON. APPLY SECOND COAT AS RECOMMENDED BY MANUFACTURER.
 - D. METAL - ALL METAL SURFACES SHALL BE PAINTED WITH TWO COATS OF ALKYL FINISH COAT OVER ZINC CHROMATE OR EQUAL RUST INHIBITING PRIMER.
 - E. RAMP - ONE COAT OF FERROX NON-SLIP (0.8 MIN. C.O.F.) SURFACING AS MANUFACTURED BY AMERICAN ABRASIVE METALS OR COMPARABLE. ALL PAINTS OF THE TYPE INDICATED SHALL BE LISTED ON THE STATE OF CALIFORNIA QUALIFIED PRODUCTS LIST FOR MAINTENANCE PAINTS 8010-910-98A DATED JULY 1989. OR EQUAL.
 - F. SUBMIT ONE SET COLOR SAMPLES TO ARCHITECT FOR EACH PRODUCT TO ASSIST IN SELECTION.

SECTION 13F SITE ASSEMBLY

1. SCOPE OF WORK
CONTRACTOR SHALL PROVIDE ALL LABOR MATERIALS AND SERVICES TO PREPARE THE BUILDING ELEMENTS, TRANSPORT THEM FROM THE PLANT TO THE SITE AND TO COMPLETE THE ASSEMBLY AT THE SITE. THE CONDITION OF THE SITE, SUCH AS DRAINAGE AND SOIL BEARING CAPACITY, SHALL BE THE RESPONSIBILITY OF THE SCHOOL DISTRICT. UNLESS SPECIFICALLY CALLED FOR IN THE CONTRACT, STEPS, RAMPS, OR HANDRAILS SHALL BE THE RESPONSIBILITY OF THE CONTRACTOR.
2. ASSEMBLY OF ELEMENTS
 - A. IN A LOCATION ON THE SITE AS DETERMINED BY THE SCHOOL DISTRICT (APPROVED BY DSA) THE CONTRACTOR SHALL PLACE WOOD LEVELING STRIPS OR OTHER SUITABLE SUPPORTS AS DETAILED ON THE DRAWINGS.
 - B. THE ELEMENTS SHALL BE BROUGHT TO THE SITE ON WHEEL ASSEMBLY AND TRANSFERRED TO THE PREPARED SITE. GREAT CARE SHALL BE TAKEN TO AVOID DAMAGE TO THE ELEMENTS BY RACKING OR BUMPING EACH OTHER.

- C. CONNECTION OF THE ELEMENTS TOGETHER SHALL BE DONE ACCORDING TO INSTRUCTION ON THE DRAWINGS. FLASHINGS, TRIM AND OTHER LOOSE ITEMS SHALL BE INSTALLED PER DETAILS ON THE DRAWINGS.

SECTION 15A AIR CONDITIONING

1. SCOPE OF WORK (SEE SHEET M3 FOR HVAC SPEC. AND NOTES)
CONTRACTOR SHALL PROVIDE ALL LABOR, MATERIALS AND SERVICES TO INSTALL THE AIR CONDITIONING SYSTEM AS SHOWN ON THE DRAWINGS AND SPECIFICATIONS, INCLUDING A/C UNITS AND ACCESSORIES, REMOTE THERMOSTAT, GRILLS AND POWER WIRING COMPLETE TO LOAD CENTER. CONTRACTOR SHALL INSTRUCT OWNER'S OPERATORS ON OPERATION AND MAINTENANCE OF A/C SYSTEM.
2. EQUIPMENT
SEE NOTE ON FLOOR PLAN FOR SIZE AND TYPE.
3. WORKMANSHIP
UNITS SHALL BE INSTALLED COMPLETE AND OPERATING WITH ALL ACCESSORIES IN ACCORDANCE WITH THE MANUFACTURER'S INSTRUCTIONS.

SECTION 16A ELECTRICAL

1. SCOPE OF WORK
CONTRACTOR SHALL PROVIDE ALL LABOR, MATERIALS AND SERVICES FOR ELECTRICAL INSTALLATION COMPLETE WITH ASSOCIATED EQUIPMENT AND FIXTURES, IN OPERATING CONDITION READY FOR USE. THE WORK INCLUDES: LIGHT AND POWER SYSTEMS, LIGHTING FIXTURES COMPLETE WITH LAMPS, CONNECTIONS AND DISCONNECTS TO A/C EQUIPMENT.
- A. PROVIDE CONDUIT WITH PULL STRINGS AND JUNCTION BOXES FOR AUTOMATIC DETECTION FIRE ALARM SYSTEM AND NOTIFICATION PER NFPA 72
2. MATERIALS
ALL NEW COMPLYING WITH REQUIREMENTS OF CALIFORNIA ELECTRIC CODE AND NATIONAL FIRE PROTECTION ASSOCIATION
- A. ELECTRIC METALLIC TUBING - COUPLING AND FLEX CONDUIT GALVANIZED OR SHERARIZED, EXTERIOR FLEX- GALV. STEEL W/ FACTORY APPLIED P.V.C. JACKET.
- B. PANELBOARDS - FLUSH MOUNTED.
- C. CONDUCTORS - COPPER, INSULATED FOR 600 VOLTS, TYPE THHN FOR SIZES #12 TO #6, TYPE THW FOR LARGER SIZES. MINIMUM SIZE- #14.
- D. RECEPTACLES - AS NOTED. +18" A.F.F. MIN.
- E. CLOCK RECEPTACLE - AS NOTED.
- F. SWITCHES - AS NOTED. +48" A.F.F. MAX.
- G. LIGHTING FIXTURES - AS NOTED ON THE DRAWINGS.
3. WORKMANSHIP
MATERIALS AND EQUIPMENT INSTALLED IN A SECURE, NEAT WORKMANLIKE MANNER IN ACCORDANCE WITH CODE REQUIREMENTS. PANELBOARD CARDS FILLED OUT. CONDUIT AND CABLE INSTALLED IN WALL AND CEILING SPACES. WORK PIERCING WATERPROOFED AREAS FLASHED AND SEALED TO A WATERTIGHT CONDITION. BUILDING CONDUIT/WIRING FROM FACE OF BLDG TO SITE TERMINATION BY SITE CONTRACTOR (N.I.C.), (FLEXIBLE CONDUIT S-BEND SEALTITE)

INSPECTION

INSPECTION OF PREFABRICATED BUILDINGS IS DIVIDED INTO TWO SEPARATE FUNCTIONS.

1. IN-PLANT INSPECTION.
2. ON-SITE INSPECTION.

THE CONTRACTOR SHALL ALLOW UP TO SEVEN (7) DAYS FROM THE DATE OF PLAN APPROVAL TO OBTAIN AN IN PLANT INSPECTOR APPROVED BY D.S.A.

IN-PLANT INSPECTION AND MATERIAL TESTING SHALL BE ACCOMPLISHED UNDER THE SUPERVISION OF THE DISTRICT ARCHITECT. THE CONTRACTOR SHALL NOTIFY THE DISTRICT ARCHITECT, DSA, AND THE DESIGNATED INSPECTOR/INSPECTION AGENCY AT LEAST 48 HOURS PRIOR TO COMMENCING WORK. THE MANUFACTURER SHALL PROVIDE THE INSPECTOR WITH FULL ACCESS TO ALL PLANT OPERATIONS INVOLVING WORK UNDER THIS CONTRACT AND SHALL ADVISE THE INSPECTOR IN ADVANCE OF THE TIME AND PLACE WHEN OPERATIONS THAT THE INSPECTOR WANTS TO OBSERVE TAKE PLACE. BEFORE THE BUILDING(S) ARE REMOVED FROM THE PLANT FOR DELIVERY TO THE STORAGE FACILITY OR FROM THE STORAGE FACILITY TO THE SITE THE INSPECTOR SHALL DETERMINE THAT THEY ARE ACCEPTABLE AND ISSUE A WRITTEN RELEASE WHICH SHALL BE IN THE FORM OF A VERIFIED REPORT (FORM SSS-6). A COPY OF THE INSPECTOR'S VERIFIED REPORT SHALL ACCOMPANY EACH BUILDING TO STORAGE OR TO THE SITE. THE INSPECTOR SHALL PUT ONE COPY IN EACH BUILDING.

COORDINATION OF WORK

IT SHALL BE THE CONTRACTOR'S RESPONSIBILITY TO MAKE ALL NECESSARY ARRANGEMENTS WITH THE SCHOOL DISTRICT AUTHORIZED REPRESENTATIVE FOR ACCESS TO GROUNDS AND REMOVAL OF EQUIPMENT, IF NECESSARY. THIS CONTACT SHALL BE MADE AT LEAST 48 HOURS PRIOR TO DELIVERY OF ANY MODULE. ON-SITE INSPECTION SHALL BE DONE BY THE SITE INSPECTOR. ALL WORK WHICH THE MANUFACTURER OR HIS SUBCONTRACTORS PERFORM AT THE SITE SHALL BE SUBJECT TO THE INSPECTION OF THE SITE INSPECTOR. THE MANUFACTURER WILL FURNISH THE SITE INSPECTOR WITH SUCH INFORMATION AS MAY BE NECESSARY TO KEEP HIM FULLY INFORMED AS TO PROGRESS OF WORK AND DATES WHEN SITE WORK WILL OCCUR. THE CONTRACTOR SHALL NOTIFY THE INSPECTION AGENCY AT LEAST 48 HOURS PRIOR TO COMMENCING WORK.

THE CONTRACTOR SHALL VERIFY THAT THE DISTRICT'S SITE IS READY TO RECEIVE THE CLASSROOM(S) PRIOR TO THE DELIVERY OF ANY CLASSROOM(S) BY VISITING EACH SITE (THIS MAY BE DONE BY THE INSPECTOR).

REVISIONS		
NO	DATE	DESCRIPTION

DATE: 12/02/04
SCALE: NOTED
DRAWN BY: RL
SERIAL NO.:

CUSTOMER:
2:12 PITCHED ROOF 24' x 40' THRU 120' x 40' RELOCATABLE BUILDINGS
GENERAL NOTES

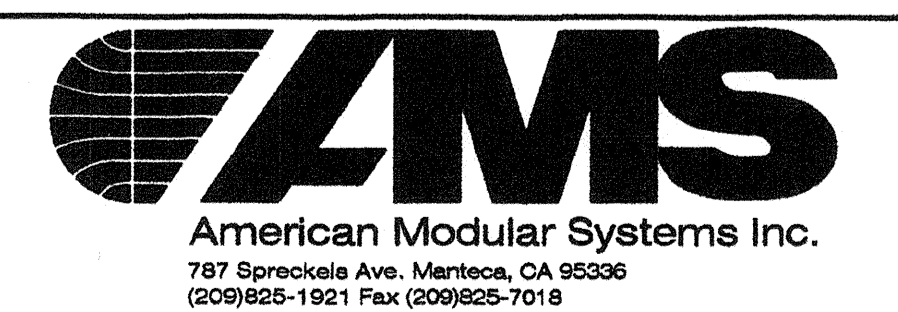

APPROVALS:
IDENTIFICATION STAMP
DIV. OF THE STATE ARCHITECT
OFFICE OF REGULATION SERVICES
No. C12631
Rev. 2.21.01
DATE: SEP 24 2009

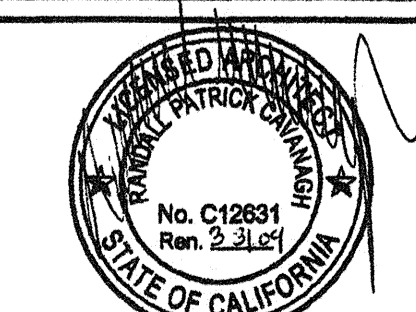

IDENTIFICATION STAMP
DIV. OF THE STATE ARCHITECT
OFFICE OF REGULATION SERVICES
PC 02-108695
AC: FLS: SSS
DATE: 3/23/09

PROJECT No.
N1

MATERIALS AND WORKMANSHIP

ALL CONTRACTORS SHALL CERTIFY THAT NO ASBESTOS-CONTAINING BUILDING MATERIALS WHICH EXCEED STATE AND FEDERAL MANDATED SAFE ASBESTOS LEVELS HAVE BEEN USED IN THE CONSTRUCTION OF RELOCATABLE FACILITIES.

ALL WORKMEN SHALL BE SKILLED AND QUALIFIED FOR THE WORK WHICH THEY PERFORM. ALL MATERIALS USED, UNLESS OTHERWISE SPECIFIED, SHALL BE NEW AND OF THE TYPES AND GRADES SPECIFIED. THE CONTRACTOR SHALL, IF REQUESTED, FURNISH EVIDENCE SATISFACTORY TO THE ARCHITECT THAT SUCH IS THE CASE.

CONTRACTOR'S CREWS ASSIGNED TO ANY WORK PERFORMED UNDER THIS CONTRACT SHALL INCLUDE ONE COMPETENT AND FULLY EXPERIENCED PERSON DESIGNATED AS THE RESPONSIBLE PERSON IN CHARGE. SUCH PERSON MUST BE IDENTIFIED BY NAME TO THE DISTRICT IN ADVANCE OF ANY WORK. UPON REQUEST, THE CONTRACTOR SHALL PROMPTLY FURNISH TO THE DISTRICT INFORMATION RELATING TO THIS EMPLOYEE'S EXPERIENCE.

WORKMANSHIP SHALL BE EQUAL OR BETTER IN QUALITY TO THAT REQUIRED BY THE CONSTRUCTION TRADES FOR A FINISHED PRODUCT. A QUALITY CONTROL SUPERVISOR, DESIGNATED BY THE MANUFACTURER, SHALL REVIEW ALL WORK IN PROGRESS AND SHALL REVIEW THE FINISHED BUILDING PRIOR TO FINAL INSPECTION TO ASSURE IT IS COMPLETE AND CORRECT. THE QUALITY CONTROL SUPERVISOR SHALL HAVE THE AUTHORITY TO HAVE MATERIALS REPLACED AND WORK REDONE IN ORDER TO CORRECT FAULTY MATERIALS OR WORKMANSHIP.

GENERAL DESIGN REQUIREMENTS:

UP TO (12) APPROXIMATELY 12' x 40' MODULES DESIGNED SO THAT TWO MODULES MAY BE JOINED TOGETHER TO FORM A COMPLETE STRUCTURE TO MAINTAIN A POSITIVE ALIGNMENT OF FLOORS, WALLS, AND ROOF AND TO PERMIT SIMPLE NON-DESTRUCTIVE DETACHMENT FOR FUTURE RELOCATION.

EACH MODULE SHALL BE PERMANENTLY IDENTIFIED WITH AN IMPRINTED (STAMPED NOT ENGRAVED) METAL IDENTIFICATION TAG 3"x1 1/2" MINIMUM SIZE WITH THE FOLLOWING INFORMATION:

1. MANUFACTURER'S NAME AND BUILDING SERIAL NUMBER.
2. DESIGN WIND LOAD / EXPOSURE
3. DESIGN ROOF LIVE LOAD
4. DESIGN FLOOR LIVE LOAD
5. D.S.A. APPLICATION NUMBER.

2-TAGS PER MODULE ONE ON EXTERIOR AND ONE ON MODULE BEAM AT FRONT OF BUILDING ABOVE CEILING.

EACH MODULE SHALL BE CAPABLE OF RESISTING ALL VERTICAL AND LATERAL LOADS DURING TRANSPORTATION AND RELOCATION. (NORMAL INDUSTRY PRACTICE FOR BRACING MODULES DURING TRANSPORTATION AND RELOCATIONS IS ACCEPTABLE.) WHEN MODULES ARE ASSEMBLED JOINTS SHALL BE SEALED WITH REMOVABLE CLOSING STRIPS OR OTHER METHOD TO PRESENT A FINISHED APPEARANCE AND BE PERMANENTLY WATERPROOF.

EACH MODULE SHALL BE SUFFICIENTLY RIGID TO BE JACKED UP AT THE FRONT AND BACK CORNERS FOR RELOCATION WITHOUT DAMAGE OR THE MODULE SHALL HAVE LIFT LUGS AT FRONT AND BACK LOCATED AS REQUIRED SO THAT THE MODULE MAY BE JACKED UP FOR RELOCATION IN ONE PIECE WITHOUT ADDITIONAL SUPPORTS OF ANY TYPE. EVIDENCE OF EXCESSIVE BOWING DURING THE INSTALLATION OF THE MODULES WHICH, IN THE OPINION OF THE AGENCY ARCHITECT OR STRUCTURAL ENGINEER, CAUSES EXCESSIVE WORKING AT ANY JOINT OR COMPROMISES THE STRUCTURAL INTEGRITY OF THE MODULE SHALL BE SUFFICIENT REASON FOR REJECTION OF THE MODULE.

FINISH AND BASE MATERIALS AT EACH MODULE SHALL TERMINATE AT INTERIOR MODULE JOINTS IN A MANNER TO JOIN FLUSH AND TIGHT WITH SAME MATERIAL IN ADJACENT MODULE SO THE MODULE MAY BE RELOCATED WITH MINIMUM CUTTING AND PATCHING.

MARKERBOARD SPECIFICATIONS

MARKERBOARDS SHALL BE 24 ga. PORCELAIN STEEL FACING SHEET SUITABLE TO ACCEPT DRY ERASE FLET MARKERS. THE FACING SHEET SHALL BE LAMINATED TO PARTICLE BOARD SUBSTRATE WITH A MINIMUM DENSITY OF 45#/c. ft.
THE PANEL SHALL HAVE A FOIL BACKING. THE PANELS SHALL HAVE EXTRUDED ALUMINUM MOLDING AND CHALKRAIL WITH A MINIMUM OF 2-1/8" PROJECTION FROM THE FACE OF PANEL. THREE MAP HOOKS WITH CLIPS PER PANEL SHALL BE PROVIDED. ONE FLAG HOLDER, 1/2" SIZE, SHALL BE PROVIDED FOR EACH CLASSROOM. EACH CLASSROOM SHALL HAVE 2 EACH 4 X 8 PANELS INSTALLED SIDE BY SIDE TO MAKE A 4 X 16 PANEL. CENTERED ON THE LONG WALLS.
REFERENCE BRANDS: CHATFIELD-CLARKE Co, Inc. SERIES 500 OR NELSON ADAMS Co. NACO SERIES 60.

NOTE:

WALL FINISH MATERIAL	PIPE INSULATION
FLAME SPREAD MAX = 200	FLAME SPREAD MAX = 25
SMOKE DENSITY MAX = 450	SMOKE DENSITY MAX = 450
BUILDING INSULATION	DUCT INSULATION
FLAME SPREAD MAX = 25	FLAME SPREAD MAX = 25
SMOKE DENSITY MAX = 450	SMOKE DENSITY MAX = 50

INTERIOR

1. FLOOR: CARPETS - CLASSROOM SHALL BE CARPETED AS INDICATED ON FLOOR PLAN WITH DIRECT GLUE DOWN TYPE PER STATE OF CALIFORNIA SPECIFICATION 7220-XXX-01, GROUP 1, TYPE A, CLASS 26. COLOR WILL BE SELECTED BY ARCHITECT AFTER AWARD OF BID. THE CARPET DENSITY SHALL BE 4600 MINIMUM. PILE YARN SHALL BE BRANDED NYLON. NO CROSS SEAMS SHALL BE ALLOWED. PILE HEIGHT 1/2" MAX
2. BASE: RESILIENT COVE BASE - BEST QUALITY, MOULDED RUBBER, 1/8" THICK, 4" HIGH, MOULDED TOP SET COVE: PROVIDE PREFORMED BASE FOR SQUARE EXTERNAL CORNERS AND PREFORMED END STOPS WHERE BASE DOES NOT ABUT. SOLID COLOR AS MANUFACTURED BY "JOHNSONITE CO.", FLEXCO, OR EQUAL. APPLY COVE TO COMPLETE PERIMETER OF CLASSROOM.
3. INTERIOR WALLS SHALL BE VINYL COVERED TACKBOARD (U.O.N.) APPLIED IN ONE CONTINUOUS LENGTH FROM FLOOR TO CEILING. THE TACKBOARD SHALL BE INDUSTRIAL INSULATION BOARD MANUFACTURED SPECIFICALLY AS A SUBSTITUTE FOR VINYL COVERED WALL PANELS. THE BOARD SHALL BE ASPHALT FREE, SHALL HAVE AN IRONED-ON COATING AND SHALL HAVE A MINIMUM DENSITY OF 18 LBS. PER FT. THE VINYL COATING SHALL BE MADE OF VIRGIN VINYL CALENDERED BASE COLOR, WEIGHING A MINIMUM OF 8 OZ. PER SQUARE YARD. THE COATING BACKING SHALL BE SHEETING OR NON-WOVEN FABRIC. THE VINYL COATING SHALL BE MECHANICALLY LAMINATED, WITH THE LONG EDGES WRAPPED, TO THE TACKBOARD. TACKBOARD SHALL BE APPLIED OVER 1/2" SHEETROCK OR PLYWOOD SHEATHING. THE VINYL WALL COVERED PANEL SHALL HAVE A CLASS III FLAME SPREAD RATING. THE PANEL SHALL BE APPROVED FOR CLASSROOM USE BY THE CALIFORNIA STATE FIRE MARSHAL. REFERENCE BRAND: VINYL COVERED TACKBOARD AS MANUFACTURED BY CHATFIELD-CLARKE OR COMPARABLE. CARE SHALL BE TAKEN IN MOUNTING THE TACKBOARD SO THAT THE TEXTURE OF ALL PANELS WILL HAVE THE SAME ORIENTATION AND COLOR MATCH.
4. CEILING: SUSPEND T-BAR SYSTEM, SEE SHEET M2 FOR DETAILS ETC. MATERIALS AND INSTALLATION PER CCR 2501.A.5 AND IR 25-2 INCLUSIVE AS APPLICABLE TO CLASSROOMS.

DOORS & WINDOWS

EXTERIOR DOORS: METAL DOORS - 3'-0"x7'-0" HOLLOW METAL DOOR CONSTRUCTION OF 1 SHEET OF 18 GA. GRADE II STEEL ASSEMBLED PER CS242 MIN AND REINFORCED WITH 20 GA. MIN. FILL DOOR SPACES WITH MINERAL WOOL OR OTHER INSULATION. (REINFORCE BOTH FACES FOR CLOSURE) PROVIDE FLUSH TOP ON DOORS. HARDWARE REINFORCEMENT SHALL BE 10 GA. MIN FOR HINGES, DOOR FRAME SHALL BE 16 GA. PRESSED STEEL FRAME ASTM A366 & CS242. HARDWARE REINFORCEMENT SHALL BE 10 GA. PLATE. FRAMES SHALL BE DESIGNED WITH INTEGRAL STOP AND TRIM. PROVIDE (3) ANCHORS PER JAMB PLUS ADJUSTABLE FLOOR ANCHOR.
EXTERIOR WINDOWS: PROVIDE ANODIZED ALUMINUM FRAME 5/8" MINIMUM DUAL PANE WINDOW UNITS, AS SHOWN ON FLOOR PLANS. THE 5/8" DIMENSION IS THE MINIMUM THICKNESS FOR THE DUAL GLAZED WINDOW PANEL CONSISTING OF TWO LIGHTS OF GLASS AND THE AIR SPACE. GLAZING MATERIAL SHALL BE:
EXTERIOR LITE - 3/16" MINIMUM TEMPERED GLASS OR LAMINATED AS - 1 GLASS OF SOLAR GRAY GLARE REDUCING TYPE WITH A LIGHT TRANSMISSION FACTOR OF 45% MAXIMUM.
INTERIOR LITE - 1/8" MINIMUM CLEAR TEMPERED.
MINIMUM AIR SPACE SHALL BE 1/4".
SPACE - BENT OR SEALED CORNER ALUMINUM WITH DESICCANT FILL SEALER - BUTYL PRIMARY SEAL AND POLYSULFIDE OF SILICONE SECONDARY SEAL.
CERTIFICATION - ALL GLAZING TO BE CERTIFIED IN ACCORDANCE WITH ASTM E-773, E-774.
HEADER HEIGHT SHALL BE THE SAME AS THE DOOR. ALL OPERABLE SASH SHALL HAVE ALUMINUM SCREENS. WINDOWS SHALL NOT BE MOUNTED TO THE EXTERIOR PLYWOOD SURFACE. ALL WINDOWS SHALL MEET THE AAMA GS101-88 VOLUNTARY SPEC. FOR ALUMINUM PRIME WINDOWS AND SLIDING GLASS (ANSI), COMMERCIAL GRADE.

HARDWARE

1. EXTERIOR DOOR
 - A) HINGES: HAGER 4-1/2x4-1/2 BUTTS, BB1279 US26D, 1-1/2 PAIR EACH DOOR WITH SET SCREW IN BARREL AND BALL BEARING DESIGN, OR APPROVED EQUAL.
 - B) EXTERIOR LOCKSET: SCHLAGE ND70PD CORBIN OR YALE OR EQUIVALENT, ALUM. FINISH. OR PANIC BARS/PULL HANDLE PANIC BAR TYPE VON DUPRIN 22L (PULL ON EXT.) OR CORBIN OR YALE OR EQUIVALENT, ALUM. FINISH. PANIC BARS ARE ONLY REQUIRED WHERE THE OCCUPANT LOAD IS 50 OR MORE.
 - C) CLOSER: NORTON 8500DA OR 8500BF SERIES, LCN 1460 DEL SERIES OR EQUAL. MAXIMUM 5 LBS FOR EXTERIOR AND INTERIOR DOORS. THE MAXIMUM EFFORT FOR FIRE DOORS MAY BE INCREASED TO THE MAXIMUM ALLOWED BY THE APPROPRIATE ADMINISTRATIVE AUTHORITY, NOT TO EXCEED 15 LBS. THE SWEEP PERIOD FROM AN OPEN POSITION OF 70 DEGREES SHALL BE AT LEAST 3 SECONDS TO MOVE TO A POINT 3 INCHES FROM THE LATCH, MEASURED TO THE LEADING EDGE OF THE DOOR.
 - D) WEATHERSTRIPPING: ALL EXTERIOR DOORS SHALL BE WEATHERSTRIPPED WITH PEMKO 299D, ULTRA W5007, AT DOOR JAMBS AND HEAD OR EQUAL.
 - E) THRESHOLD: THRESHOLD SHALL BE PEMKO 271 AV 5" ALUMINUM WITH PEMKO 216 AV ULTRA TH042 DOOR BOTTOM.
 - F) DOORSTOP: QUALITY #44, OR EQUAL.
- D) INTERIOR LOCKSET: SCHLAGE LEVER HANDLE LOCKSET, AS FOLLOWS:

STUDENT TOILETS	S10A PASSAGE LATCH OR EQUAL
OFFICES	70D CLASSROOM LOCKSET OR EQUAL
CUSTODIAL	S80A LOCKSET OR EQUAL
PUBLIC TOILETS	S40A PRIVACY LATCHSET OR EQUAL

FIRE EXTINGUISHER

1. EACH PORTABLE CLASSROOM SHALL BE EQUIPPED WITH PRESSURE TYPE FIRE EXTINGUISHERS WITH 2A10BC UL RATING. TO BE MOUNTED ON THE INTERIOR WALL OF THE BUILDING NEAR THE DOORWAY(S) AT A MAXIMUM HEIGHT OF 4 FEET TO THE MOUNTING BRACKET AND THE BOTTOM OF FE MOUNTED 27" AFF. FIRE EXTINGUISHERS SHALL BE TOTALLY CHARGED AND HAVE A DIAL INDICATING THE STATE OF CHARGE.

ACCESSIBILITY STANDARDS

2007 CALIFORNIA BUILDING CODE (PART 2, TITLE 24, CCR) SEC. 1103B.1 BUILDING ACCESSIBILITY, GENERAL.
THE 2007 CBC REQUIRES THAT BUILDINGS EXCEEDING 10,000 SQUARE FEET ON ANY FLOOR MUST HAVE AN ACCESSIBLE MEANS OF VERTICAL ACCESS VIA RAMP, ELEVATOR, OR LIFT WITHIN 200 FEET OF TRAVEL OF EACH STAIR AND EACH STAIR AND EACH ESCALATOR. TABLE 1115B-1 SUGGESTED DIMENSIONS FOR CHILDREN'S USE.
THE 2007 CBC REQUIRES A 27" MINIMUM DIMENSION FOR LAVATORY/SINK KNEE CLEARANCE, WHICH IS THE DISTANCE FROM THE FINISH FLOOR TO THE UNDERSIDE OF THE LAVATORY/SINK.
SECTION 1115B.3.1 ACCESSIBLE WATER CLOSET COMPARTMENT. THE 2007 CBC REQUIRES AN ACCESSIBLE TOILET STALL TO HAVE A MINIMUM WIDTH OF 60" AND SHALL BE EQUIPPED WITH A DOOR THAT HAS AN AUTOMATIC-CLOSING DEVICE, AND SHALL HAVE A CLEAR, UNOBSTRUCTED OPENING WIDTH OF 32 INCHES WHEN LOCATED AT THE END AND 34 INCHES WHEN LOCATED AT THE SIDE WITH THE DOOR POSITIONED AT AN ANGLE OF 90 DEGREES FROM ITS CLOSED POSITION. THE INSIDE AND OUTSIDE OF THE COMPARTMENT DOOR SHALL BE EQUIPPED WITH A LOOP OR U-SHAPED HANDLE IMMEDIATELY BELOW THE LATCH. THE LATCH SHALL BE FLIP-OVER STYLE, SLIDING OR OTHER HARDWARE NOT REQUIRING THE USER TO GRASP OR TWIST. EXCEPT FOR DOOR-OPENING WIDTHS AND DOOR SWINGS, A CLEAR, UNOBSTRUCTED ACCESS OF NOT LESS THAN 44 INCHES SHALL BE PROVIDED TO THE WATER CLOSET COMPARTMENTS DESIGNED FOR USE BY PERSONS WITH DISABILITIES.
SECTION 1115B.4.4.4. WATER CONTROLS. THE 2007 CBC REQUIRES THAT THE FORCE TO OPERATE A WATER CONTROL (VALVE) FOR AN ACCESSIBLE SHOWER SHALL NOT EXCEED 5LBS. MAXIMUM FORCE (PULL).
SECTION 1117B.5 SIGNS AND IDENTIFICATION (ALSO REFER TO SECTIONS 1115B.6, 1116B, 1007.6.5 1007.7, 1008.1.8.6, 1011.3, 1020.1.5 & 1020.1.6.1-5)
THE 2007 CBC MAKES SEVERAL GENERAL DESIGN CHANGES AND CLARIFICATIONS TO SIGNAGE.
*ALL GROUND FLOOR EXIT DOOR SHALL HAVE TACTILE EXIT SIGNAGE.
*AT STAIRS, EACH FLOOR SHALL RECEIVE TACTILE "STAIR LEVEL" SIGNAGE IN ADDITION TO SPECIAL TACTILE AT THE EXIT DISCHARGE LEVEL.
*EACH EXIT DOOR THAT LEADS TO A GRADE LEVEL EXIT BY MEANS OF A STAIRWAY SHALL HAVE TACTILE EXIT SIGNAGE.
*EACH EXIT ACCESS DOOR TO A CORRIDOR OR HALLWAY THAT IS REQUIRED TO HAVE A VISUAL EXIT SIGN SHALL BE IDENTIFIED BY TACTILE EXIT SIGNAGE.
SECTION 1129B ACCESSIBLE PARKING REQUIRED.
THE 2001 CBC REQUIRES THE WORDS "NO PARKING", IN 12" HEIGHT WHITE LETTERS, TO BE PAINTED ON THE PAVEMENT WITHIN ALL PARKING SPACE ACCESS AISLES. VAN PARKING ACCESS AISLES SHALL BE PLACED ON THE PASSENGER SIDE OF THE VEHICLE. RAMP MAY NOT ENCRoACH INTO ANY REQUIRED ACCESS AISLE. PARKING SPACE ACCESS AISLES SHALL NOT EXCEED 2% SLOPE IN ANY DIRECTION.*
*EXISTING SITES:
AT EXISTING SITES, ANY RAMP WHICH EXCEEDS A 2% SLOPE ACCESS AISLES FOR ACCESSIBLE PARKING SPACES PER CBCS SECTION 1129B, MAY REQUIRED REMOVAL AND REDESIGN PER THE PATH OF TRAVEL (POT) PROVISIONS OF CBCS SECTION 1134B, IN ORDER TO APPROVE THE BUILDING PLACEMENT.
SECTION 1133B.2.5 CLOSURE EFFORT TO OPERATE DOORS.
THE 2007 CBC REQUIRES THAT THE EFFORT TO OPEN AN EXTERIOR DOOR SHALL NOT EXCEED 5 POUNDS (PULL).
THE 2007 CBC REQUIRES THAT THE SWEEP PERIOD OF ACCESSIBLE DOORS SHALL BE 3 SECONDS MAXIMUM, BASED ON AN OPEN DOOR POSITION OF 70 DEGREES (FROM CLOSED), TO A DOOR POSITION OF 3" FROM THE LATCH.
SECTIONS 1133B.2.4.5 & 1133B.2.5.3 RECESSED DOORS.
THE 2007 CBC REQUIRES THAT DOORS RECESSED 8" OR MORE SHALL HAVE STRIKE EDGE CLEARANCES IN ACCORDANCE WITH FIGURE 11B-33 (A).
SECTION 1133B.4.2.4 HANDRAIL ORIENTATION.
THE 2007 CBC SPECIFIES THAT AT LEAST ONE HANDRAIL SHALL BE PARALLEL TO THE DIRECTION OF THE STAIR RUN, AND PERPENDICULAR TO THE EDGE OF THE STAIR NOSING.
SECTION 1133B.5.2 RAMP WIDTH:
MINIMUM 48" CLEAR AT OCCUPANT LOAD 300 OR LESS, 60" CLEAR AT OCCUPANT LOAD MORE THAN 300.
RADIUS MINIMUM OF 0.125"
THE 2001 CBC REQUIRES THAT SIGN EDGES LESS THAN 80" ABOVE THE FINISHED FLOOR MUST CONTAIN ROUNDED OR EASED RADIUS MINIMUM OF 0.125"
THE PROJECT PLANS OR SPECIFICATIONS SHALL INDICATE THE REQUIREMENT THAT THE MANUFACTURER SHALL PROVIDE A WRITTEN FIVE-YEAR PRODUCT WARRANTY, IN ACCORDANCE WITH THE BULLETIN.

LIGHT GAUGE METAL STUDS

1. ALL GALVANIZED STUDS AND JOISTS SHALL BE FORMED FROM STEEL THAT CORRESPONDS TO THE MINIMUM REQUIREMENTS OF THE 2001 AISI/COS/ANSI.
2. ALL GALVANIZED STUDS, JOISTS, TRACK, BRIDGING AND ACCESSORIES SHALL BE FORMED FROM STEEL HAVING A GALVANIZED COATING MEETING THE REQUIREMENTS OF ASTM A 653
3. GALVANIZED FRAMING PRODUCTS SHALL BE COATED IN ACCORDANCE WITH REQUIREMENTS OF ASTM A 653. PRODUCTS WILL BE FURNISHED WITH A G-60 OR EQUIVALENT COATING IF SPECIFIED AND ORDERED TO BE IN CONFORMANCE WITH ASTM C-955 OTHERWISE, G-40 OR EQUIVALENT COATING WILL BE PROVIDED.

METAL FLOOR DECK

1. SECTION PROPERTIES SHALL BE DERIVED IN ACCORDANCE WITH AISI " SPECIFICATION FOR DESIGN OF COLD-FORMED STEEL STRUCTURAL MEMBERS, LATEST EDITION."
2. METAL DECKING IS TO BE ATTACHED TO THE STRUCTURAL FRAME IN CONFORMANCE WITH AWS D1.1 AND D1.3 "SPECIFICATION FOR WELDING SHEET STEEL IN STRUCTURES."
3. ASTM REFERENCE NUMBERS:
A) ASTM A653, STEEL SHEET, ZINC-COATED (GALVANIZED) OR ZINC-IRON ALLOY-COATED (GALVANNEALED) BY THE HOT-DIP PROCESS STRUCTURAL (PHYSICAL) QUALITY.
4. STEEL DECK INSTITUTE (SDI)-METAL FLOOR DECK PROFILES SHALL BE IN CONFORMANCE WITH SDI STANDARDS.
5. METAL FLOOR DECK TO BE ASC STEEL DECK
 1. B-36, 18 GAUGE 1 1/2" DEEP X 36" WIDE
 - N-24, 18 GAUGE 3" DEEP X 24" WIDE
6. DECK UNITS ARE TO BE FABRICATED FROM SHEET STEEL CONFORMING TO ASTM A653, Fy=38 KSI WITH A GALVANIZED COATING, G-60 OR G-90.

REVISIONS		
NO.	DATE	DESCRIPTION

DATE: 01/20/09
SCALE: NOTED
DRAWN BY: RL
SERIAL NO.:

CUSTOMER:
2:12 PITCHED ROOF 24' x 40' THRU 120' x 40' RELOCATABLE CLASSROOMS
GENERAL NOTES



APPROVALS:

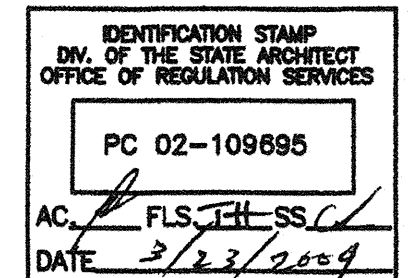
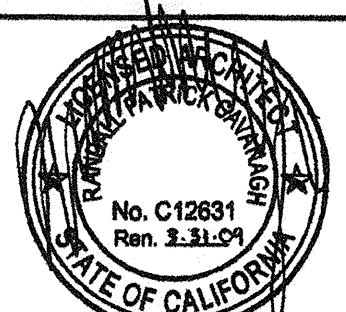

PROJECT No.
N2

THESE DRAWINGS ARE THE PROPERTY OF AMERICAN MODULAR SYSTEMS, INC. AND ARE NOT TO BE REPRODUCED, CHANGED OR COPIED IN ANY FORM OR MANNER, NOR ARE THEY TO BE ASSIGNED TO ANY THIRD PARTY WITHOUT THE WRITTEN AUTHORIZATION OF AMERICAN MODULAR SYSTEMS, INC.

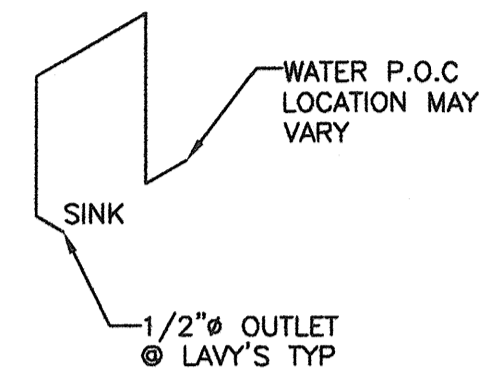

A WATER SUPPLY ISOMETRIC
P1 NO SCALE

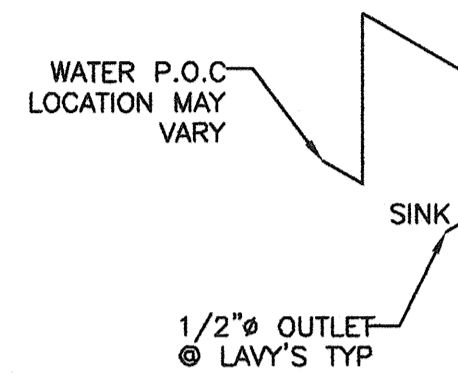

A.1 WATER SUPPLY ISOMETRIC
P1 NO SCALE

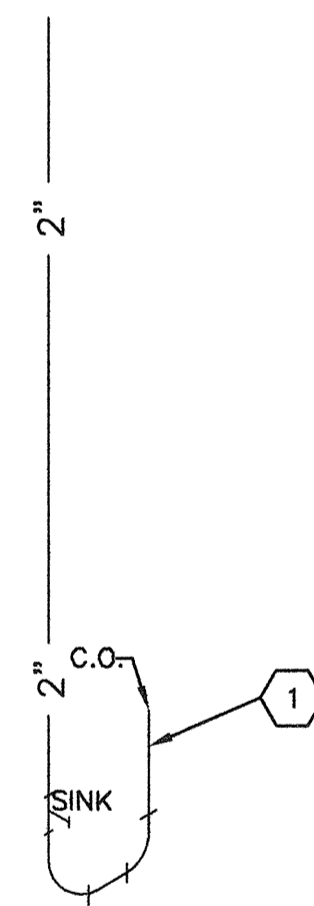

B WASTE ISOMETRIC
P1 NO SCALE

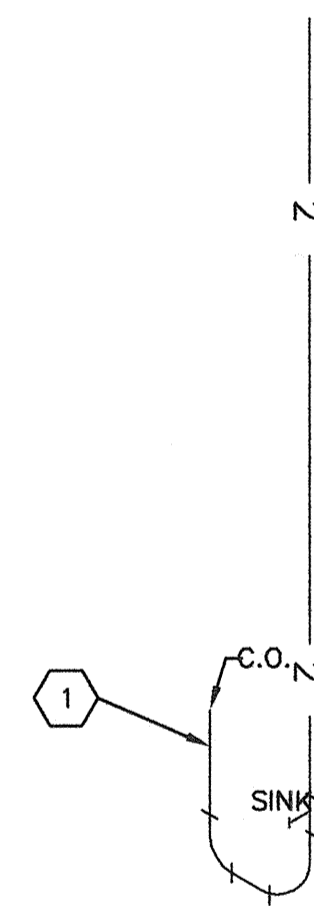

B.1 WASTE ISOMETRIC
P1 NO SCALE

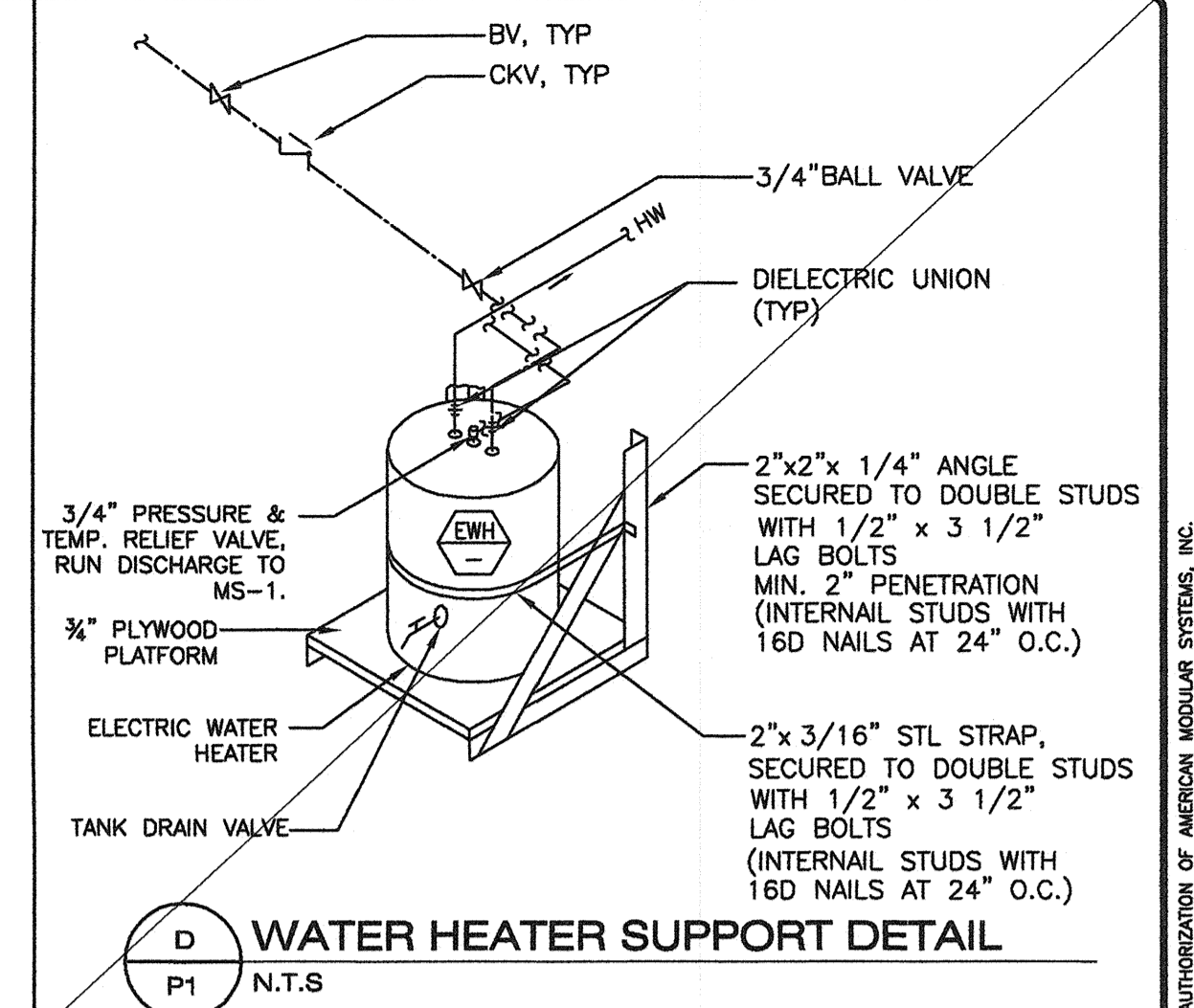

D WATER HEATER SUPPORT DETAIL
P1 N.T.S

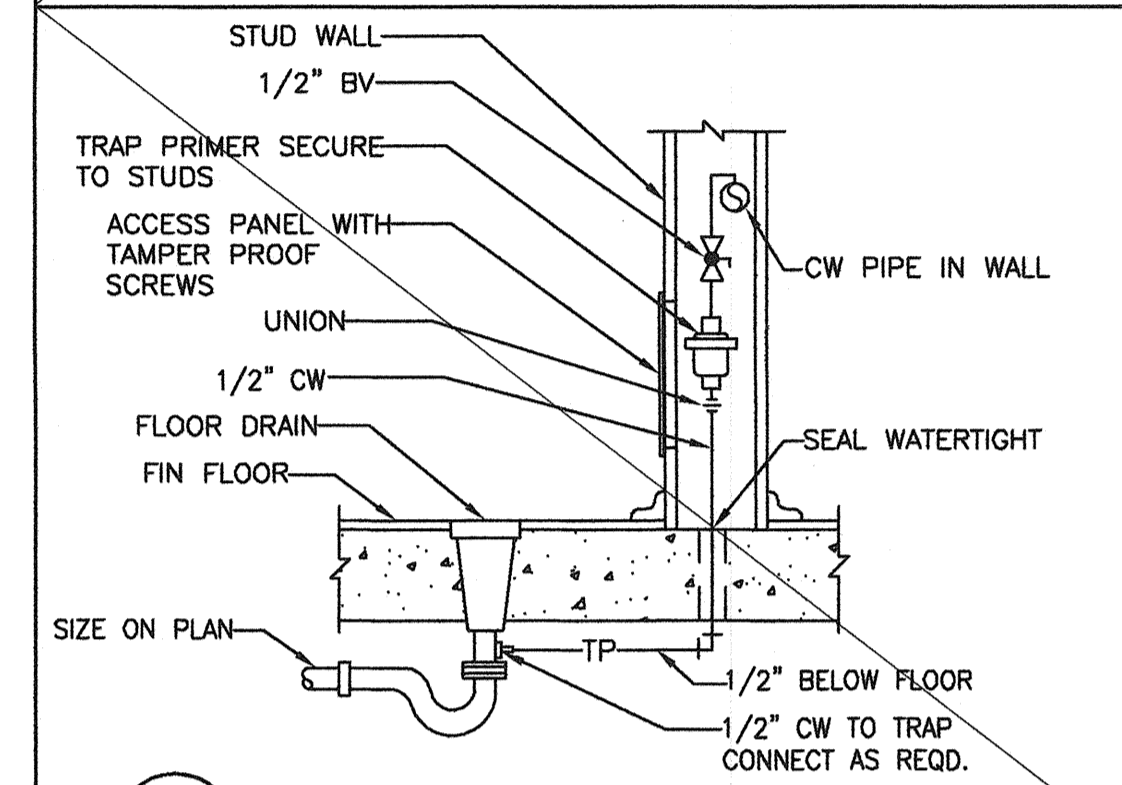

E TRAP PRIMER DETAIL
P1 N.T.S

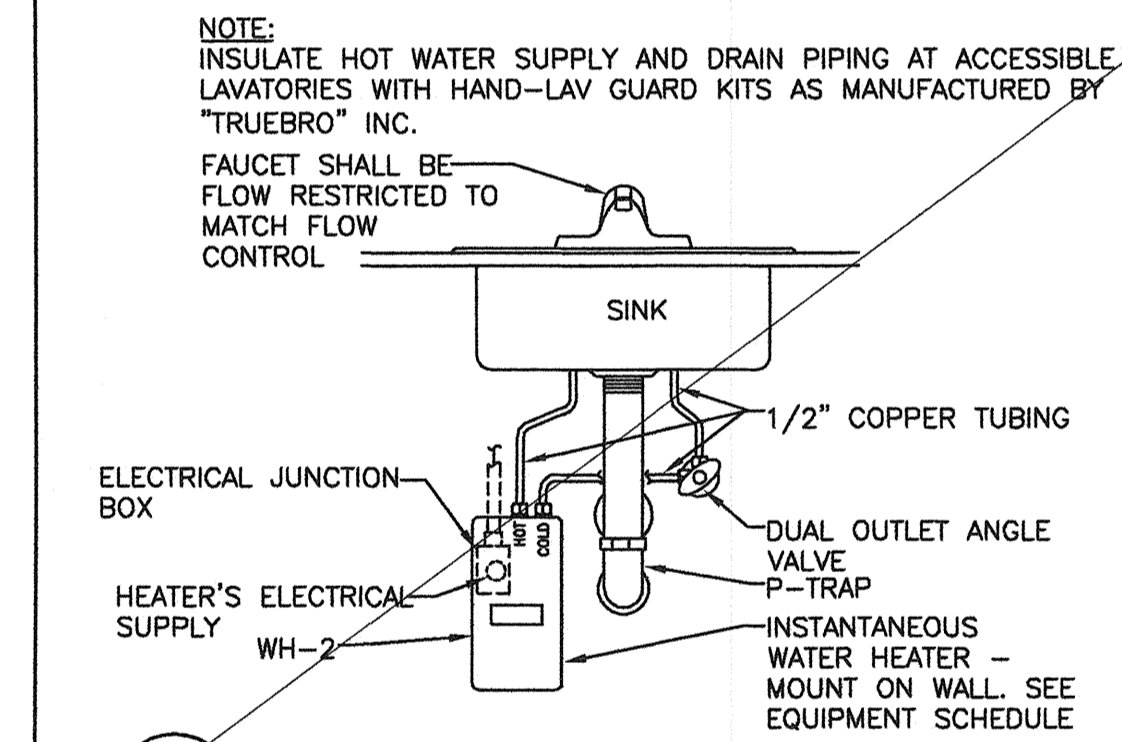

F INSTANT WATER HEATER DETAIL
P1 N.T.S

SHEET NOTES

- DWV PIPING SHALL BE ABS PLASTIC
- COLD WATER SUPPLY SHALL BE TYPE L COPPER
- DWV PIPING:
MIN SLOPE 1/4" PER FOOT
MAY SLOPE 4" CI @ 1/8" PER FOOT
VENTS SHALL TERMINATE NOT LESS THAN 10 FEET FROM OR AT LEAST 3 FT. ABOVE ANY WINDOW, DOOR, AIR INTAKE OR VENT SHAFT, NOR LESS THAN 3FT. IN EVERY DIRECTION FROM ANY LOT LINE; ALLEY AND STREET EXCEPTED; EXTEND 6" ABOVE THE ROOF

BASED ON PC# 02-109635

REVISIONS		
NO	DATE	DESCRIPTION

DATE: 08/13/09
SCALE: NOTED
DRAWN BY: RS
SERIAL NO.:

CUSTOMER: BAKERSFIELD CITY SCHOOLS
MUNSEY AND FREMONT ELEMENTARY SCHOOL

2:12 PITCHED ROOF 24' x 40' RELOCATABLE BUILDINGS
ISOMETRIC PLANS & DETAILS



APPROVALS:

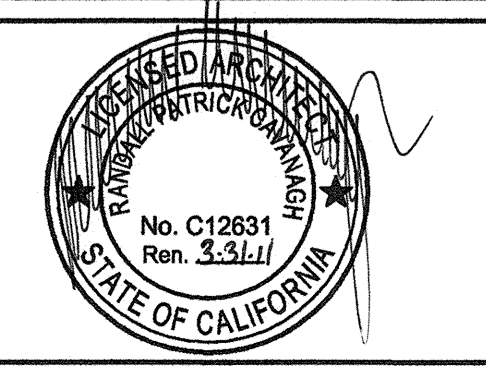

IDENTIFICATION STAMP
DIV. OF THE STATE ARCHITECT
OFFICE OF REGULATION SERVICES
AC, FLS, SS
DATE: SEP 24 2009

PROJECT No.
P1

THESE DRAWINGS AND SPECIFICATIONS ARE THE PROPERTY OF AMERICAN MODULAR SYSTEMS, INC. AND ARE NOT TO BE REPRODUCED, CHANGED OR COPIED IN ANY FORM OR MANNER, NOR ARE THEY TO BE ASSIGNED TO ANY THIRD PARTY WITHOUT THE WRITTEN AUTHORIZATION OF AMERICAN MODULAR SYSTEMS, INC.

- SHEET NOTES -

- 1 WALL HUNG HVAC UNIT
- 2 THERMOSTAT @ +60" SEALED
- 3 MAIN RUNNER TYP
- 4 CROSS RUNNER TYP
- 5 INTERIOR LIGHT FIXTURE REFER TO SHEET SHEET E1 FOR SPEC'S
- 6 CEILING HEIGHT @ 8'-6" NOM
- 7 SPLAY WIRE SEE 4/M2 FOR DETAILS
- 8 FIXED CEILING END
- 9 FREE CEILING END
- 10 CENTER SECTION THAT CROSSES MODULE LINE TO BE FIELD INSTALLED
- 11 NOT USED
- 12 CONCEALED SUPPLY AIR DUCT ABOVE T-BAR CEILING
- 13 TYPICAL 4-WAY SUPPLY AIR REGISTER LOCATION AND SIZE MAY VARY PER CEILING LAYOUT AND BUILDING SIZE

NOTE:
 WHERE TWO OR MORE HVAC UNITS SERVE A COMMON SPACE, UNITS SHALL BE EQUIPPED WITH DUCT SMOKE DETECTOR FOR AUTO SHUTDOWN. INTERCONNECT WITH FIRE ALARM SYSTEM
 AUTOMATIC SHUT-OFF IS NOT REQUIRED WHEN ALL OCCUPIED ROOMS SERVED BY THE AIR HANDLING EQUIPMENT HAVE DIRECT ACCESS TO THE EXTERIOR AND THE TRAVEL DISTANCE DO NOT EXCEEDS 100 FT. PER CMC 609 EXEPTION #2

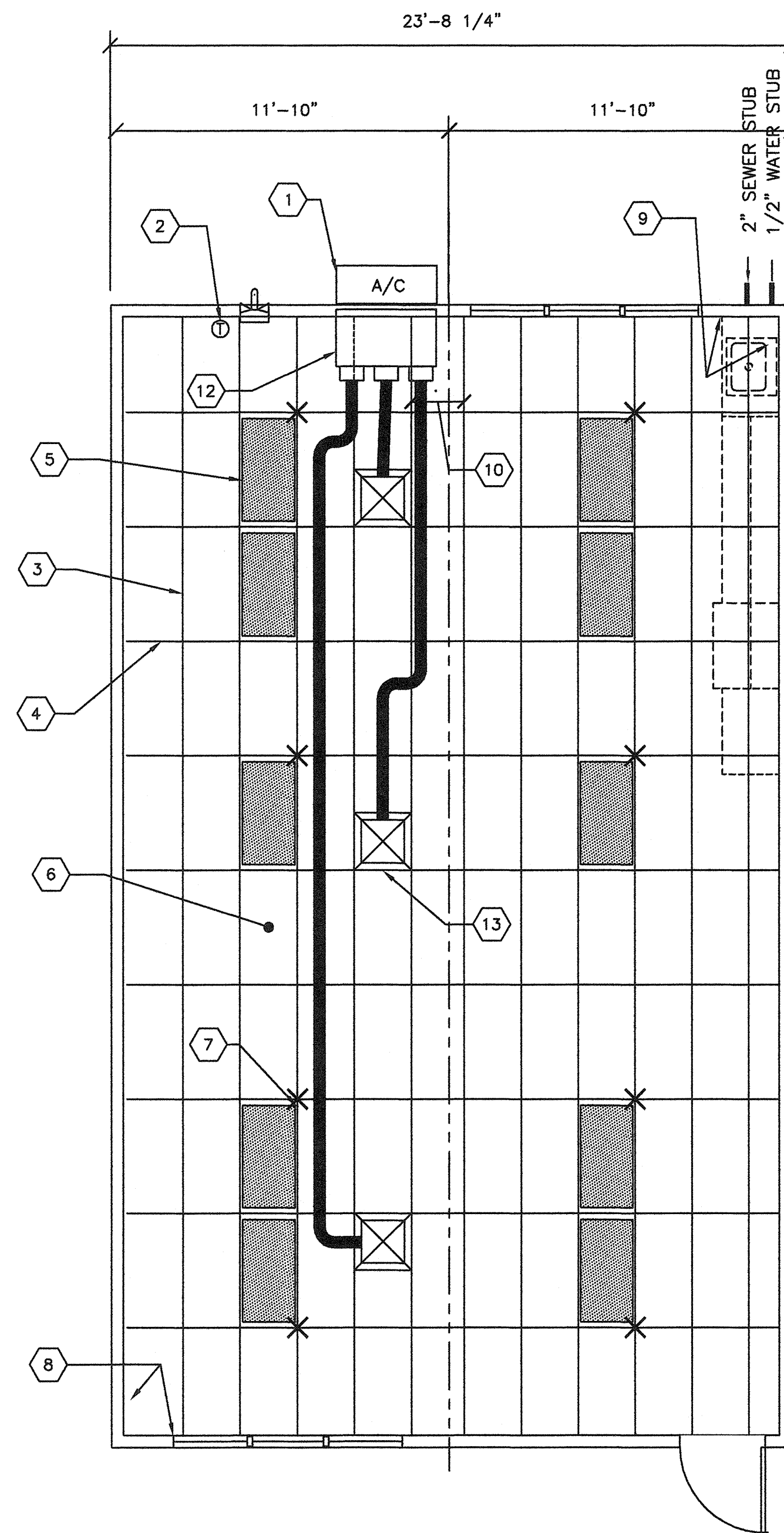

1 TYPICAL REFLECTED CEILING PLAN
 M1 1/4"=1'-0"

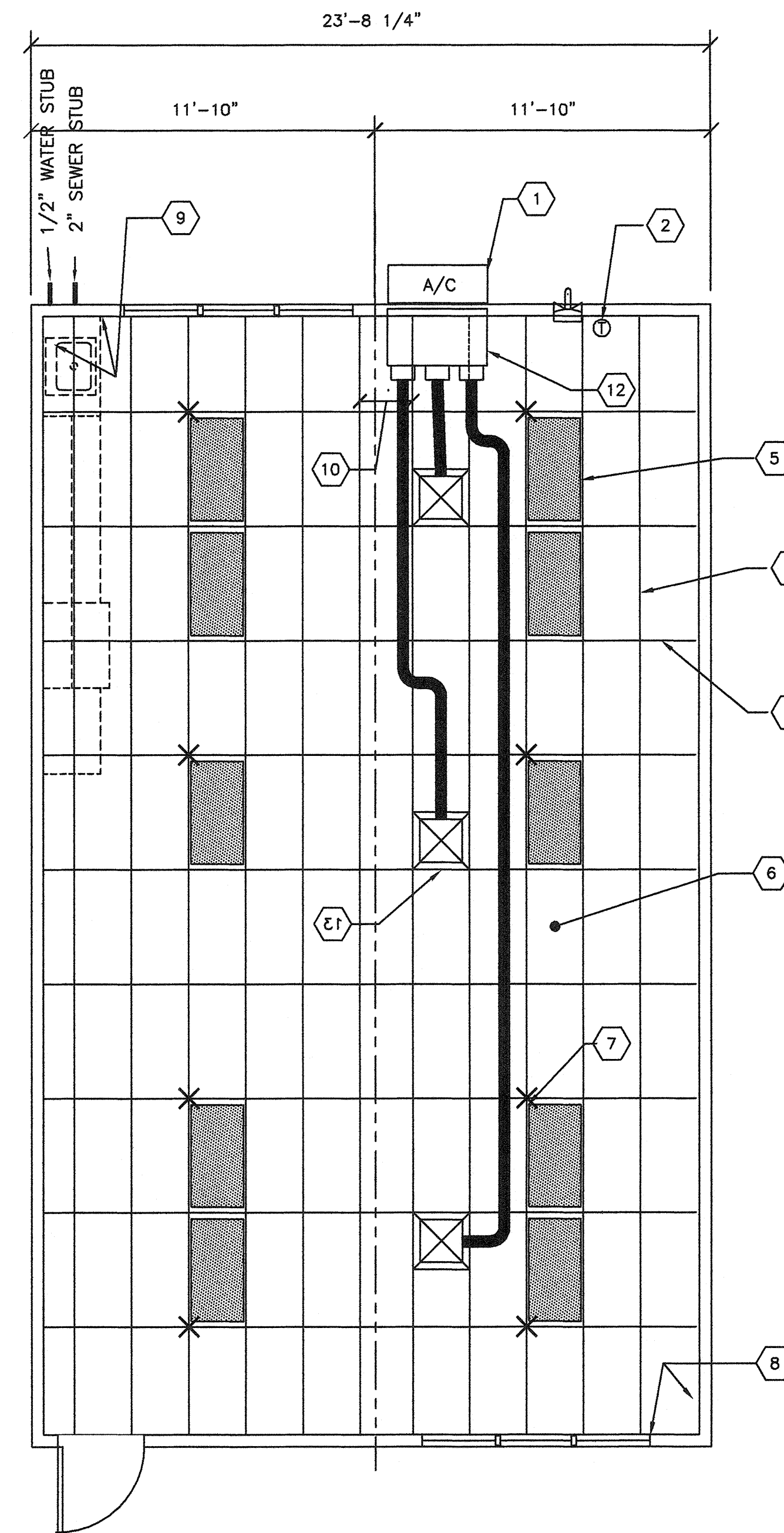

2 TYPICAL REFLECTED CEILING PLAN
 M1 1/4"=1'-0"

REVISIONS		
NO	DATE	DESCRIPTION

DATE: 08/13/09
 SCALE: NOTED
 DRAWN BY: RS
 SERIAL NO.:

CUSTOMER:
 BAKERSFIELD CITY SCHOOLS
 MUNSEY AND FREMONT SCHOOL ELEMENTARY SCHOOL

24' x 40' RELOCATABLE BUILDINGS
 TYPICAL REFLECTED CEILING PLAN



APPROVALS:

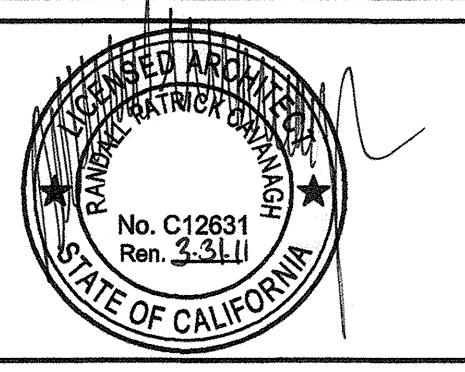

IDENTIFICATION STAMP
 DIV. OF THE STATE ARCHITECT
 OFFICE OF REGULATION SERVICES
 OS 112435
 AC, FLS, SS
 DATE: SEP 24 2009

PROJECT No.
 PC
M1

BASED ON PC 02-109695

THESE DRAWINGS AND SPECIFICATIONS ARE THE PROPERTY OF AMERICAN MODULAR SYSTEMS, INC. AND ARE NOT TO BE REPRODUCED, CHANGED OR COPIED IN ANY FORM OR MANNER, NOR ARE THEY TO BE ASSIGNED TO ANY THIRD PARTY WITHOUT THE WRITTEN AUTHORIZATION OF AMERICAN MODULAR SYSTEMS, INC.