

FOUNDATION PLAN

1/4" = 1'-0"

LEGEND

- 1 1/2"x12" WIDE x 48" LONG, UNO ON PLAN, PT STRUCTURAL PLYWOOD W/ FACE GRAIN IN SHORT DIRECTION (CDX PLYWOOD)
- 2 NOT USED
- 3 2x10x8'-0" LONG, UNO ON PLAN, PT R ALT. 2x10 REDWOOD
- 4 2x8x8'-0" LONG, UNO ON PLAN, R
- 5 NOT USED
- 6 2x8x4'-0" LONG, UNO ON PLAN, R
- 7 2x10x4'-0" LONG, UNO ON PLAN, R (PT R WHERE PLYWOOD DOES NOT OCCUR)
- 8 MULTIPLE 2x6x8'-0" LONG, UNO ON PLAN, AS REQ'D FOR HEIGHT
- 9 MULTIPLE 2x6x4'-0" LONG, UNO ON PLAN, AS REQ'D FOR HEIGHT
- 10 2x10 R W/ SHIM, SEE 2/S1
- 11 2x10 BLKG, SEE 2/S1
- 12 (4) 2x12x2'-0" PT R OR (5) 2x10x2'-0" PT R OR (6) 2x8x2'-0" PT R, SEE 2/S1
- 13 (4) 2x12x2'-0" PT R OR (4) 2x10x2'-0" PT R OR (5) 2x8x2'-0" PT R, SEE 2/S1

1" Ø GALV. PIPE LOCATIONS-TYPICAL

- NOTES:**
- TOP OF WOOD PADS TO BE LEVEL.
 - DO NOT INSTAL BUILDINGS IN AREAS OF WATER LINES.
 - SITE TO BE GRADED TO PREVENT WATER PONDING BENEATH THE STRUCTURE.
 - FOUNDATION PLYWOOD TO BE CUT PERPENDICULAR TO THE FACE GRAIN.
 - PER THE CONTRACT OF THIS PROJECT-THE BUILDING PAD MUST BE A MINIMUM OF 30'x50' AND SHALL NOT EXCEED 6" OUT OF LEVEL IN ANY DIRECTION.
 - VENT AREA REQUIRED = $\frac{1000 \times 50}{1000} = 6.4$ SF
VENT AREA PROVIDED = 6.4 SF

- SILL RESTRAINT:**
- ON SOIL: 1" Ø HOT DIPPED GALV PIPE W/ 12" MIN PENETRATION BELOW SOIL SURFACE @ 10'-0" OC, MIN 2 EA 2x R. DRILL SILL 1 1/4" MAX. PIPE MAY BE DRIVEN MAX 45° ANGLE TO VERTICAL.
- ON A/C PAVING: 1" Ø HOT DIPPED GALV PIPE W/ 12" MIN PENETRATION BELOW PAVING SURFACE @ 10'-0" OC, MIN 2 EA 2x R. DRILL SILL 1 1/4" MAX. ALT: 60d HOT DIPPED GALV NAILS THRU PREDRILLED SILL R @ 32" OC.
- ON CONC PAVING: 1" Ø HOT DIPPED GALV PIPE W/ 12" MIN PENETRATION BELOW PAVING SURFACE @ 10'-0" OC, MIN 2 EA 2x R. DRILL SILL 1 1/4" MAX. ALT: 1/2" HILTI KBI'S THRU SILL R W/ 3/2" MIN CONC EMBEDMENT @ 5'-0" OC MAX.

FOUNDATIONS:

ALL FOUNDATION MATERIALS IN CONTACT WITH THE GROUND SHALL BE PRESSURE TREATED EXCEPT SHIMS MAY BE REDWOOD, HEM FIR OR CEDAR. PRESSURE TREATED DOUGLAS FIR, HEM FIR, PLYWOOD ETC. SHALL BE VERIFIED BY A CERTIFICATE OF TREATMENT STATING: "THE MATERIAL IN THIS UNIT WAS TREATED PER 2001 CALIFORNIA BUILDING CODE. ALL MATERIAL FOR USE IN GROUND CONTACT SHALL BE STAMPED "FOR GROUND CONTACT" (LP22). ALL MATERIAL NOT USED IN GROUND CONTACT SHALL BE HF#2 OR DF#2 "FOR ABOVE GROUND USE." THE IN-PLANT INSPECTOR SHALL VERIFY THAT ALL PRESSURE TREATED FOUNDATION MATERIAL IS CUT FROM ANWP STAMPED STOCK AND THAT ALL CUTS AND HOLES ARE RE-TREATED PER SPECIFICATIONS. LP-2 AND LP-22 MATERIAL SHALL BE Banded SEPARATELY FOR SHIPMENT TO THE JOB SITE. THE IN-PLANT INSPECTOR'S VERIFICATION OF EACH Banded UNIT SHALL BE ATTACHED TO THE MATERIAL.

CONCRETE OR CONCRETE BLOCK FOUNDATIONS ARE NOT ALLOWED. THE FOOTING DESIGN SHALL PROVIDE FOR SHIMS AND BLOCKS NECESSARY TO PERMIT INSTALLATION ON SITES NOT LEVEL, BUT WITHIN TOLERANCE ALLOWED.

INSTALLATION SHALL BE PERMITTED ON EITHER SOIL, CONCRETE OR A/C PAVING, HAVING SUITABLE DESIGN BEARING CAPACITY. THE BUILDINGS SHALL BE SECURELY FASTENED TO THE FOUNDATIONS. THE FOUNDATIONS AND THE METHOD OF FASTENING SHALL BE SUBJECT TO APPROVAL BY THE ARCHITECT AND DSA. PADS SHALL NOT BE PLACED ON TURF.

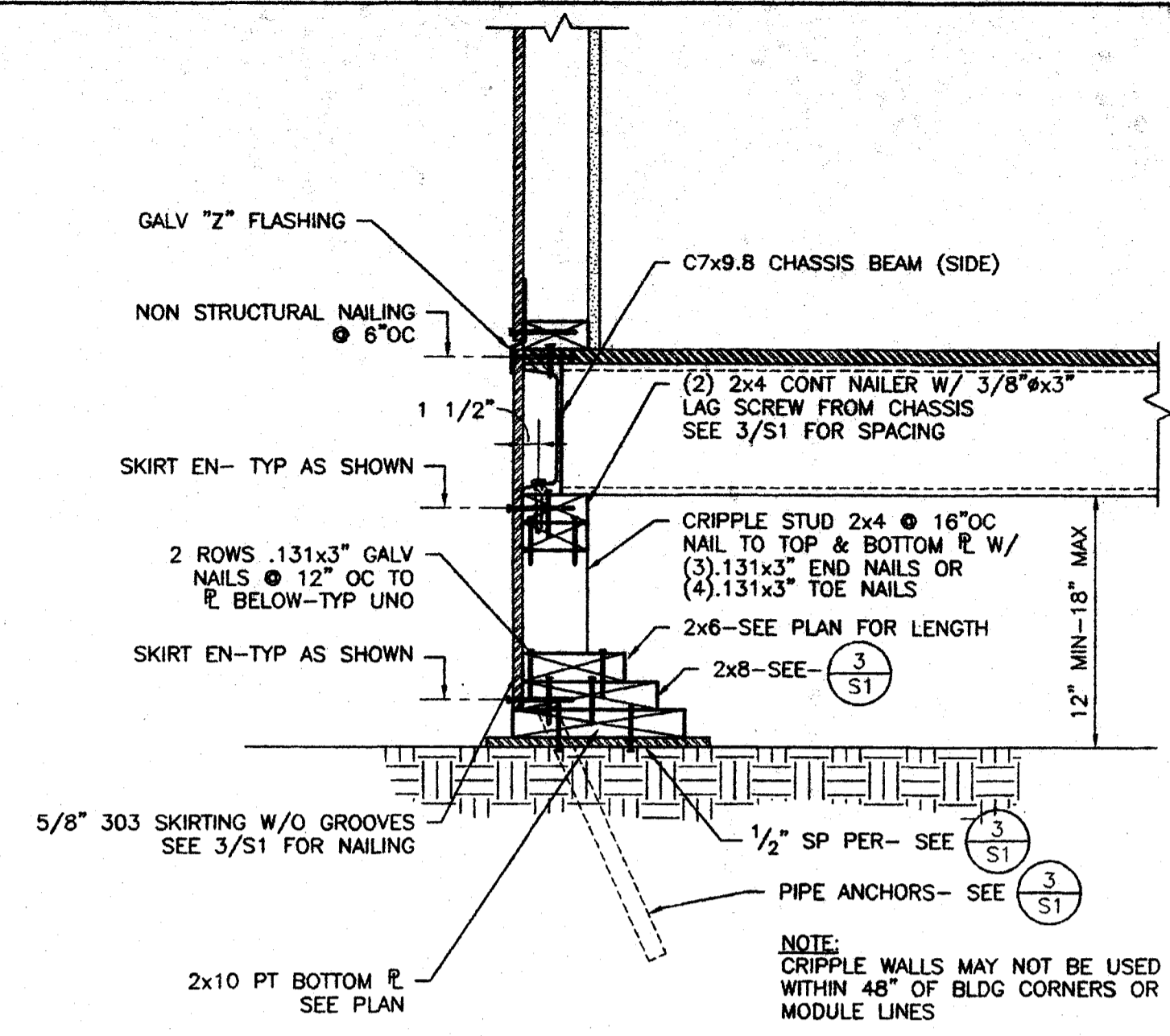

FOUNDATION DETAIL

1 1/2" = 1'-0"

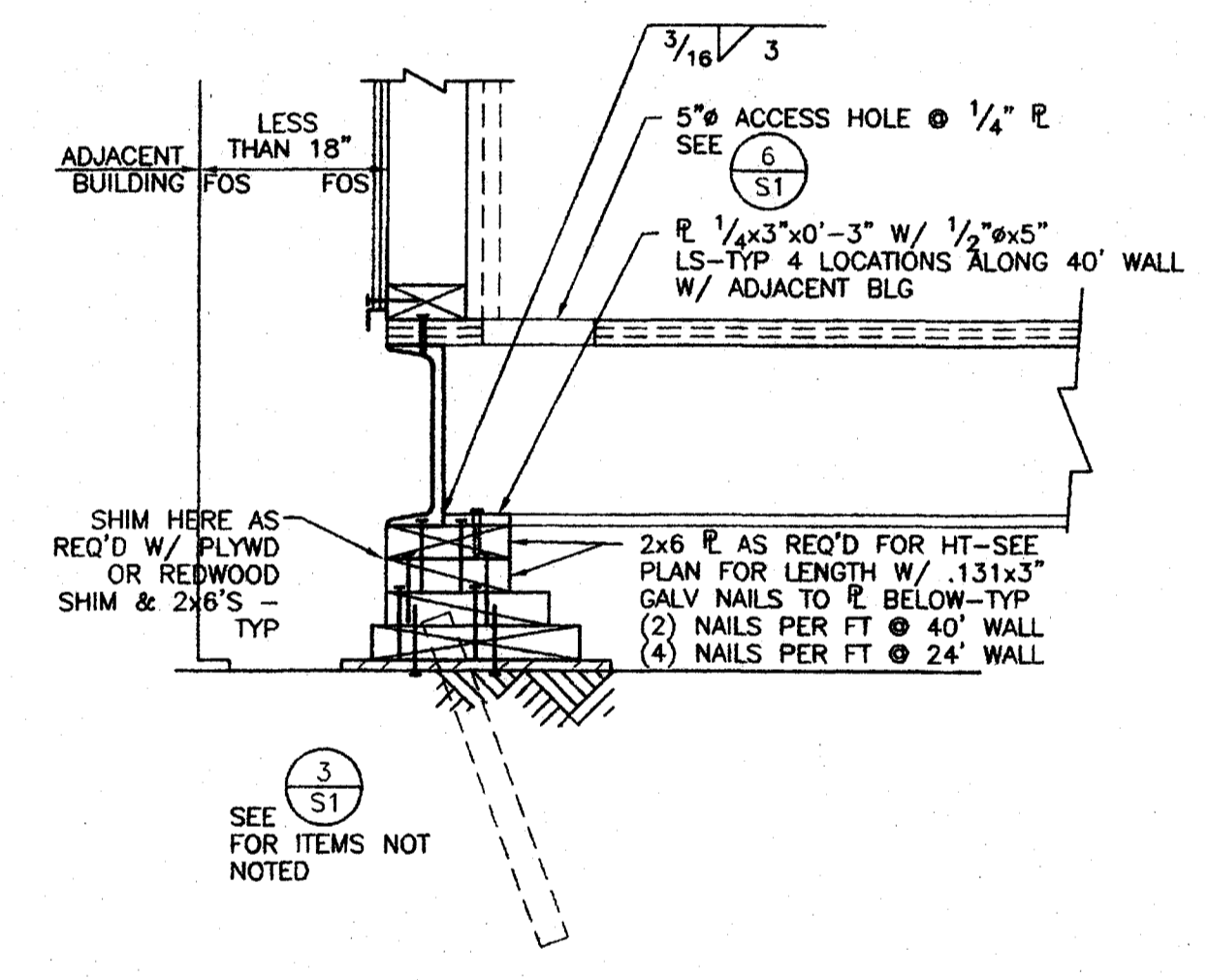

OPTIONAL FOR BUILDING PLACES LESS THAN 18" APART

FOUNDATION DETAIL

1 1/2" = 1'-0"

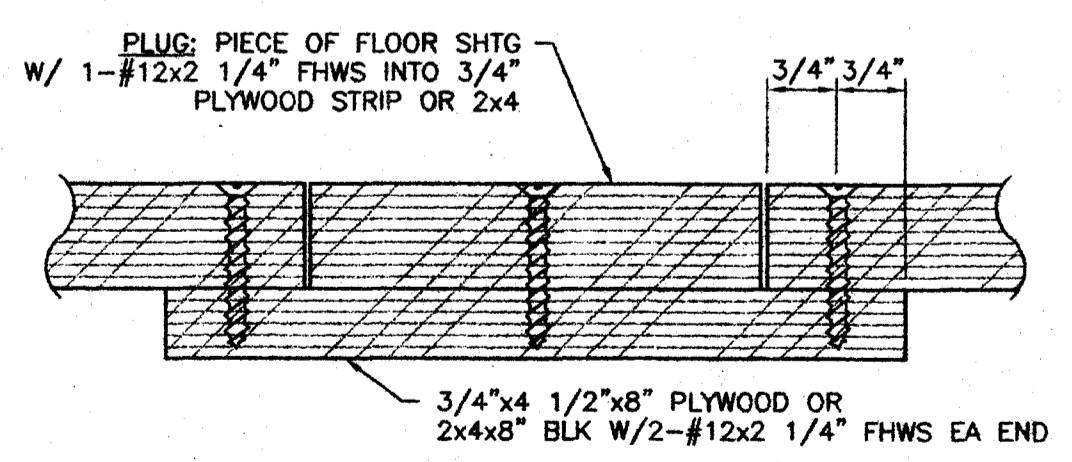

FILLER ACCESS HOLE

DETAIL

NO SCALE

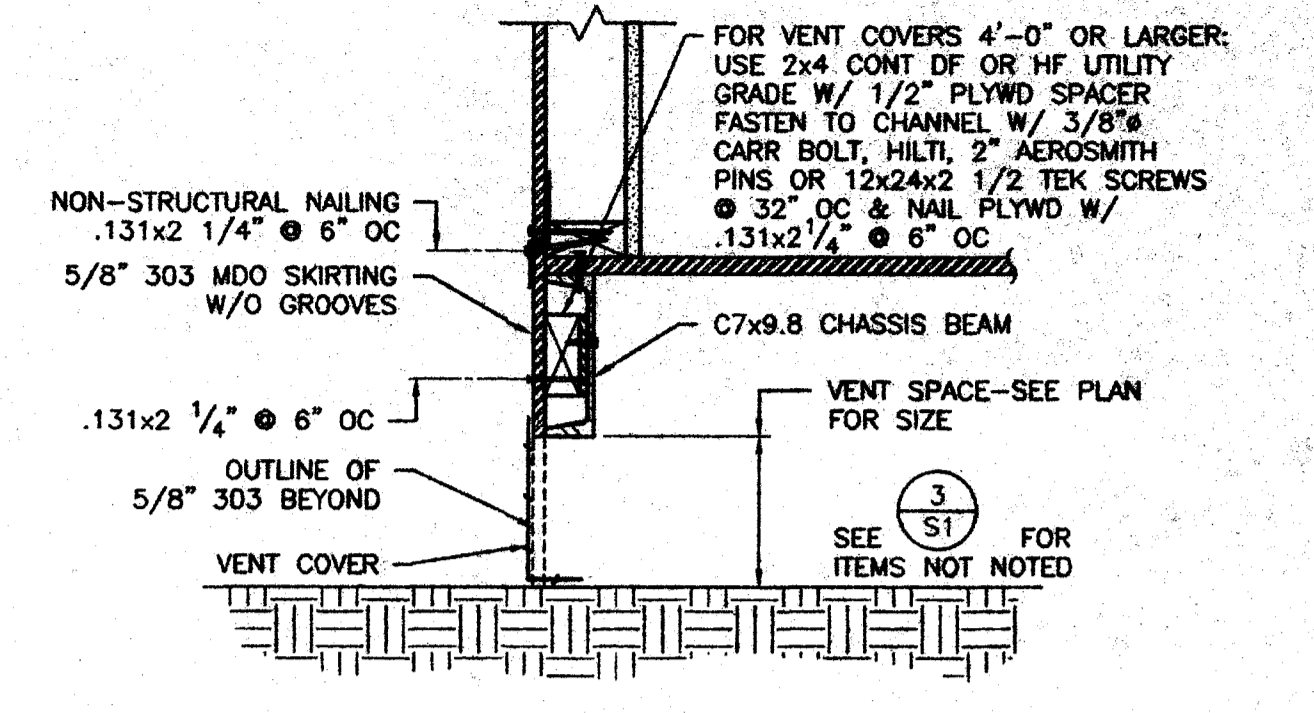

FOUNDATION DETAIL

1 1/2" = 1'-0"

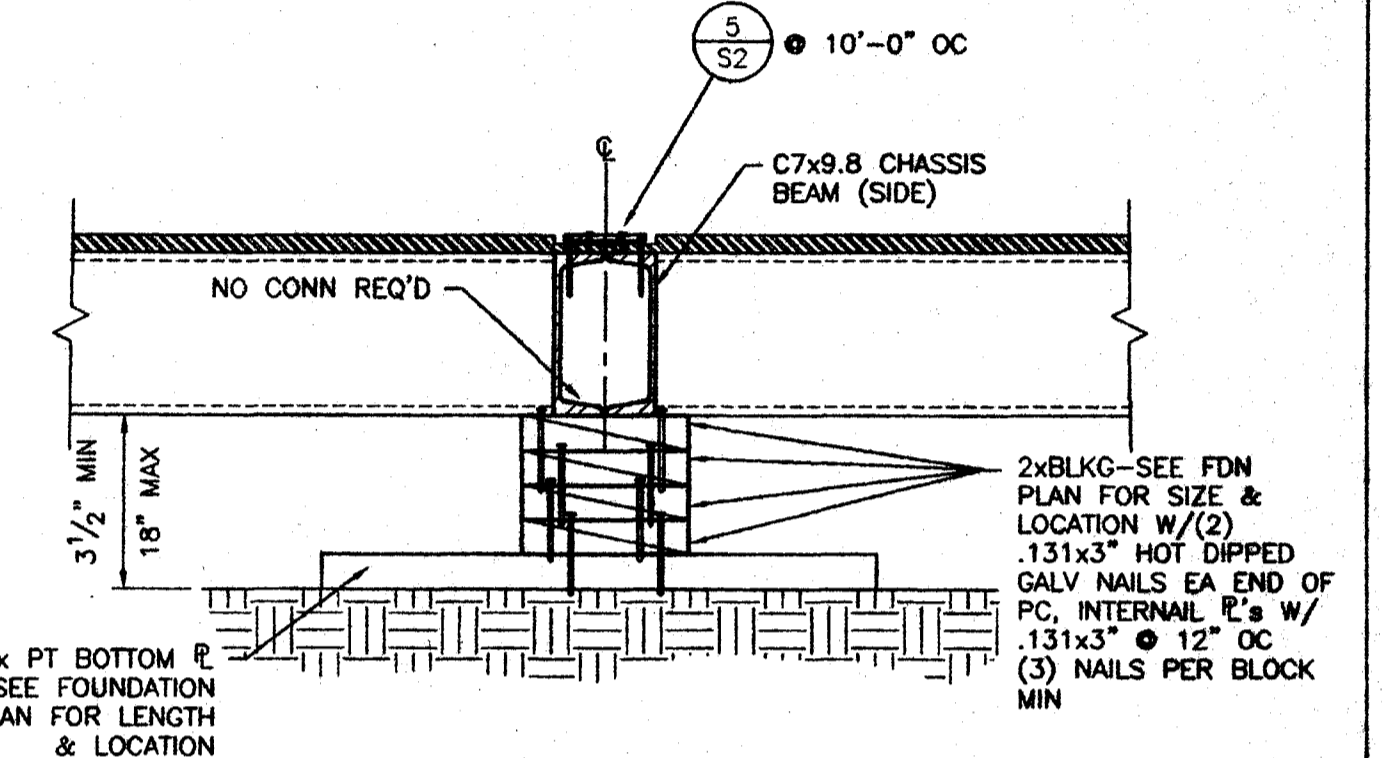

DETAIL

1 1/2" = 1'-0"

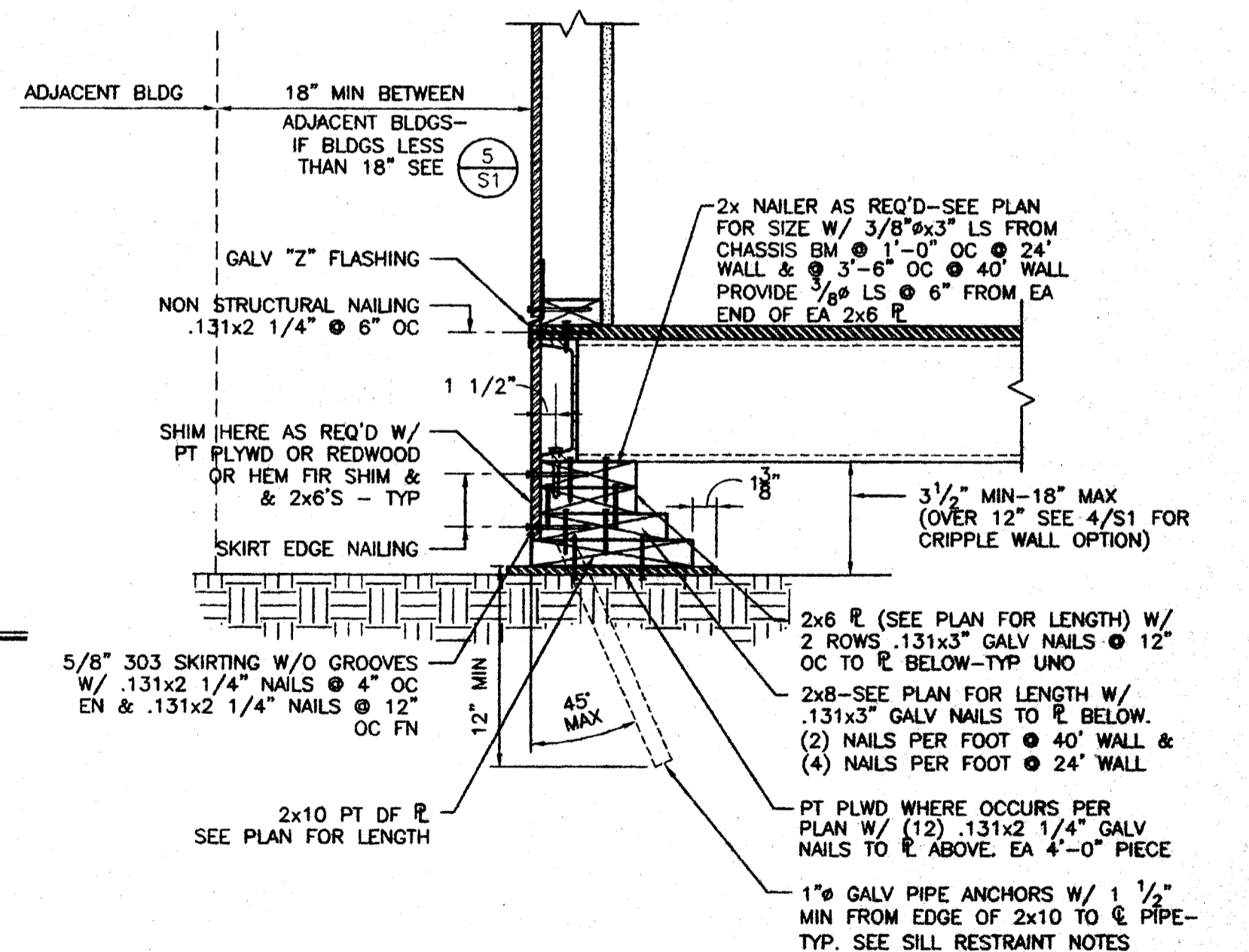

FOUNDATION DETAIL

1 1/2" = 1'-0"

IDENTIFICATION STAMP
DIV. OF THE STATE ARCHITECT
OFFICE OF REGULATION SERVICES
APPROV: 108670
DATE: JUL 26 2005

2001 CBC FILE NO. PC
IDENTIFICATION STAMP
DIV. OF THE STATE ARCHITECT
OFFICE OF REGULATION SERVICES
APPLICATION NO. 02-104915
DATE: JUL 22 2005

24 x 40
RELOCATABLE
CLASSROOM



CUSTOMER: _____

DATE: 5/30/03
SCALE: AS NOTED
DRAWN BY: REM
DESIGNED BY: MDB
CHECKED BY: KAL
SERIAL NO. _____

WOOD FOUNDATION PLAN & DETAILS
50 PSF FLOOR LIVE LOAD

REVISIONS

NO	DATE	DESCRIPTION	NO	DATE	DESCRIPTION

PROJECT No.
02156-01

SHEET No.
S1