

LANDING FRAME 12

SCALE: NTS

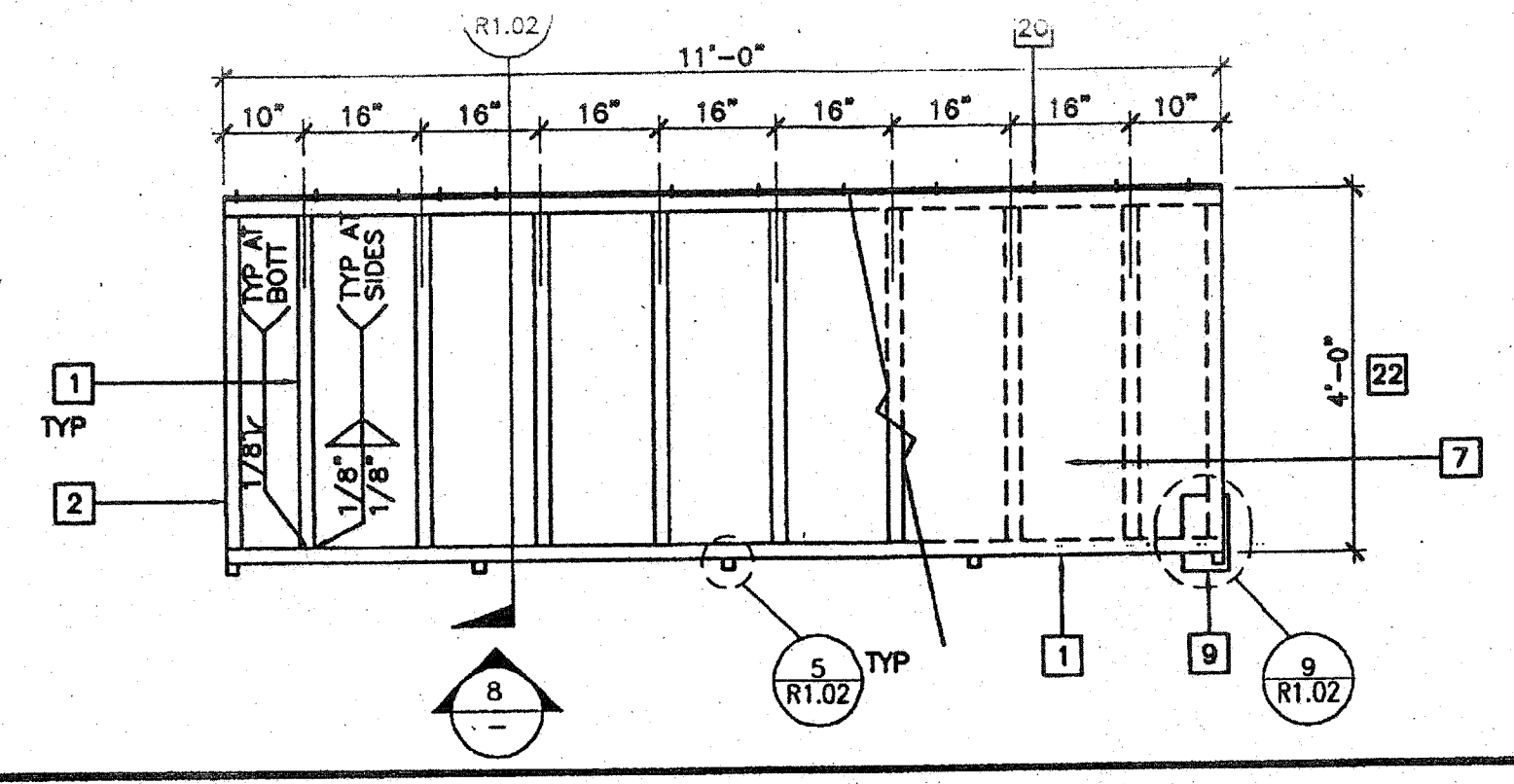

RAMP FRAME 7

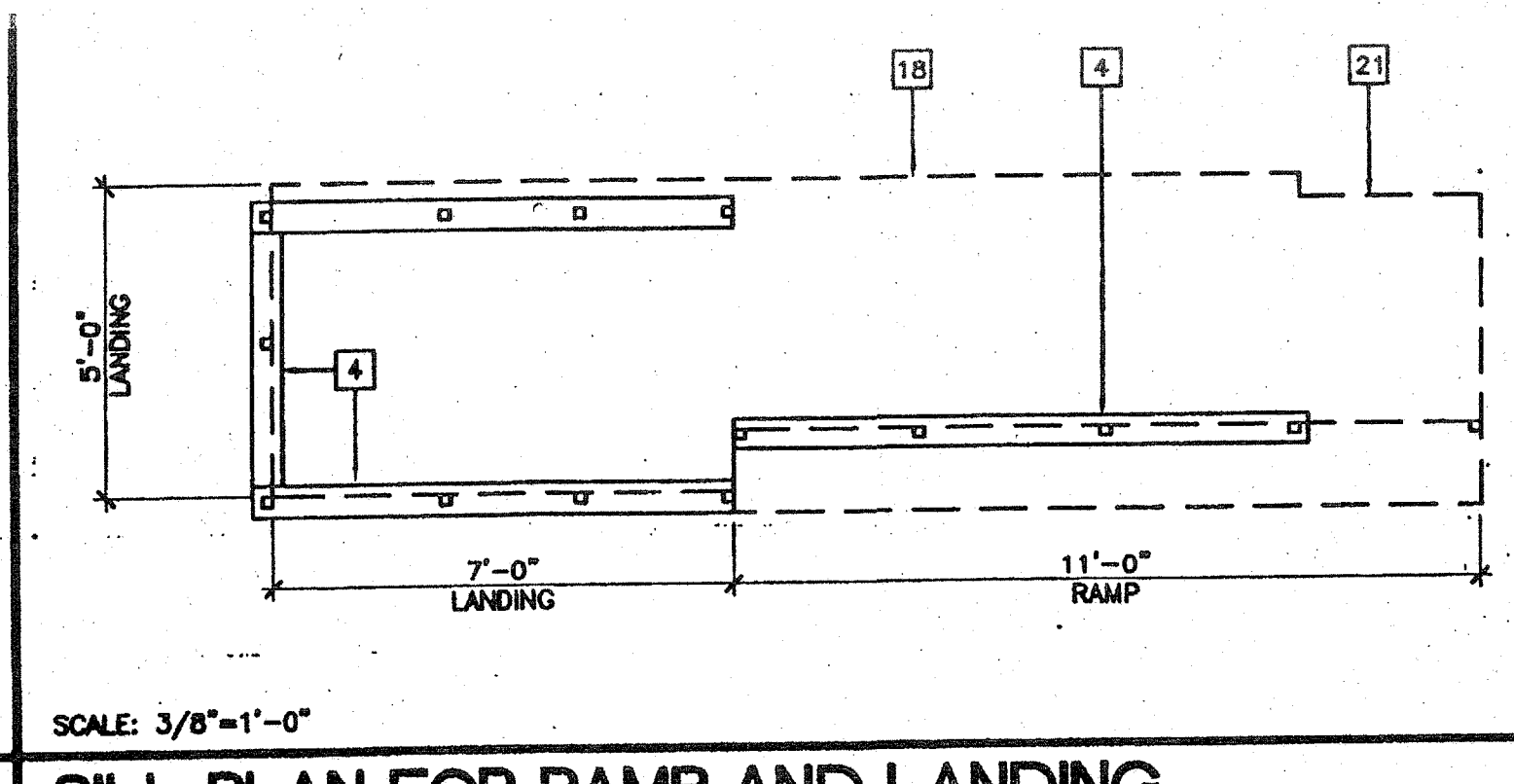

SILL PLAN FOR RAMP AND LANDING 1

SCALE: 3/8"=1'-0"

- 1 TS 2"x2"x14 GA
- 2 TS 1 1/2"x1 1/2"x14 GA (Fy = 39KSI), EASED OR ROUNDED CORNERS
- 3 TS 1"x1"x16 GA WHEELCHAIR GUIDE
- 4 2"x6" PRESSURE TREATED SILL PLATE
- 5 2"x4"x12 GA BASE PLATE WITH (2) 1/4"x1" LAGS
- 6 SKIRTING: PLYWOOD TO MATCH BUILDING SIDING. BLOCK ALL EDGES. ATTACH WITH 8d AT 8" OC EDGES AND 12" OC FIELD. AT EDGE CONNECTION TO TUBE STEEL USE #14x2" TEK SCREWS AT 8" OC
- 7 12 GA METAL DECK: NON-SLIP SURFACE. DESIGN COEFFICIENT OF FRICTION GREATER THAN 0.7 C.O.F. MAINTAINABLE FOR 1 YEAR EXISTING BUILDING
- 8 6"x10"x12 GA BASE PLATE AT RAMP TOE
- 9 LOWER LANDING BY DISTRICT
- 10 RAMP BY MODTECH RAMP
- 11 FLUSH TRANSITION
- 12 6"x12"x10 GA PLATE WITH (2) 1/4"x3" LAGS TO STRUCTURAL FRAME OF BUILDING
- 13 3"x1"x3'-0"x10 GA BENT PLATE
- 14 2"x4"x 1/8" PLATE
- 15 TS 1 1/2"x1 1/2"x14 GA HANDRAIL - CONTINUOUS AND UNINTERRUPTED, ROUNDED OR BEVELED AT CORNERS
- 16 TS 1"x1"x16 GA RAIL SUPPORT
- 17 LINE OF RAMP/LANDING ABOVE
- 18 RAMP EXTENSION FRAME
- 19 6"x10 GA CONTINUOUS PLATE WITH 1/4"x2" TEK SCREWS AT 9" OC INTO WOOD OR FOUNDATION BLOCKS OR #14x2" TEK SCREWS INTO STEEL AT 9" OC
- 20 NOTCH BOTTOM PLATE (MUD SILL) AS REQUIRED TO CLEAR RAMP TOE. MAX NOTCH 1 1/2"x4'-0" LONG.
- 21 RAMP WIDTH MINIMUM CLEAR DIMENSION IS 4'-0" IF AT LEAST TWO EXIT/DISCHARGE ARE REQUIRED OR 5'-0" IF ONLY ONE EXIT/DISCHARGE IS REQUIRED. SEE CBC1133B.5.2.2
- 22

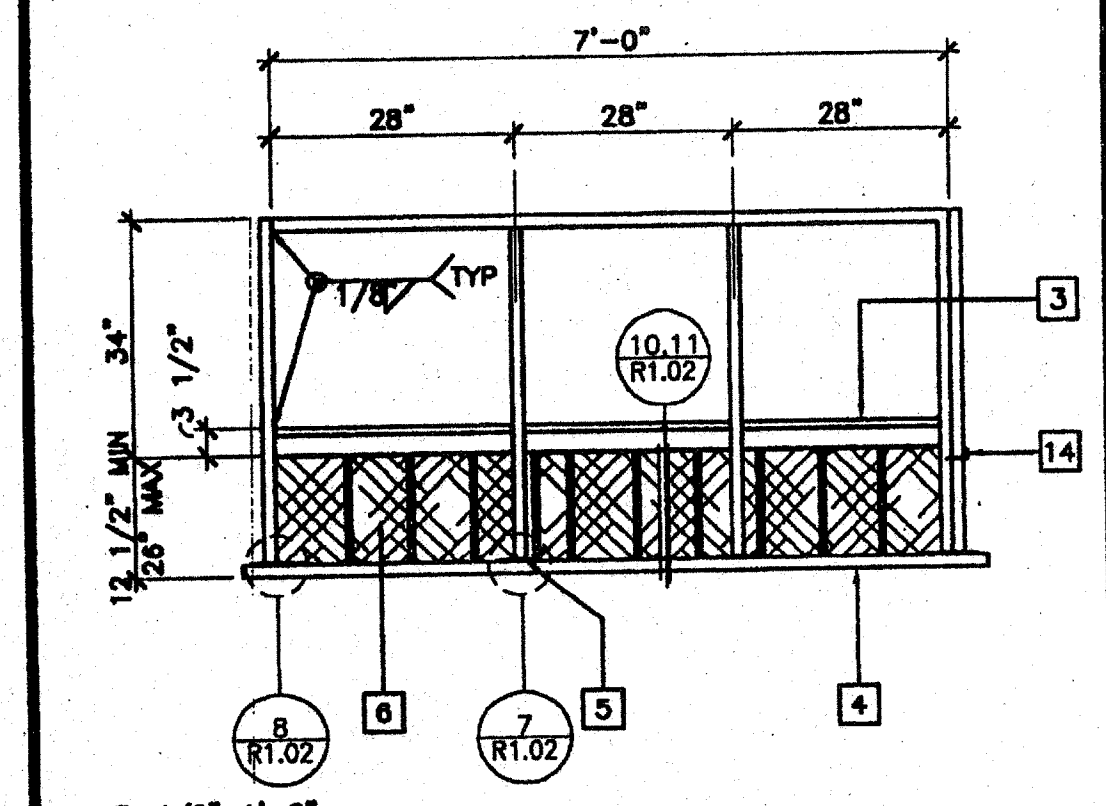

LANDING ELEVATION 13

SCALE: 1/2"=1'-0"

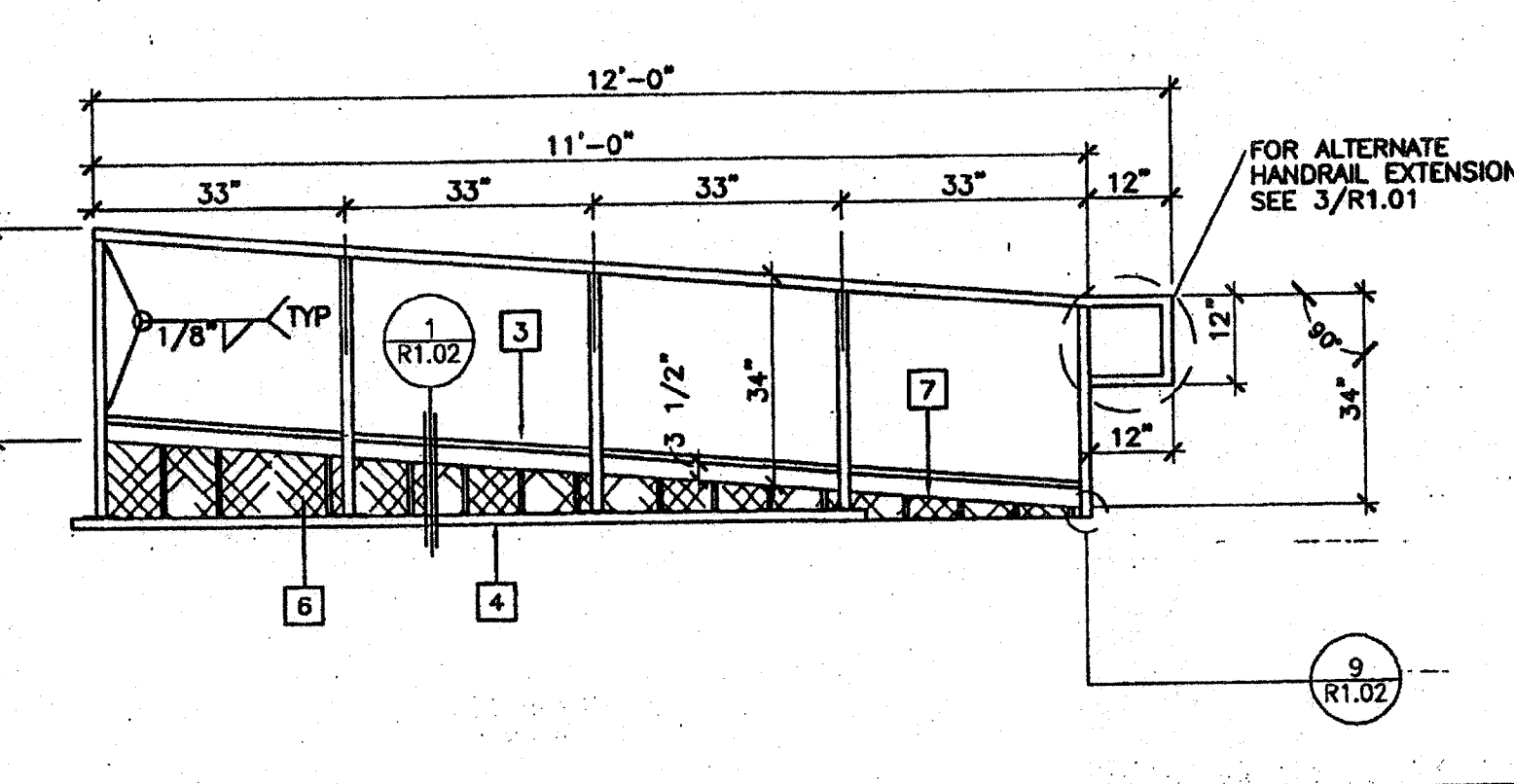

RAMP ELEVATION 8

SCALE: 1/2"=1'-0"

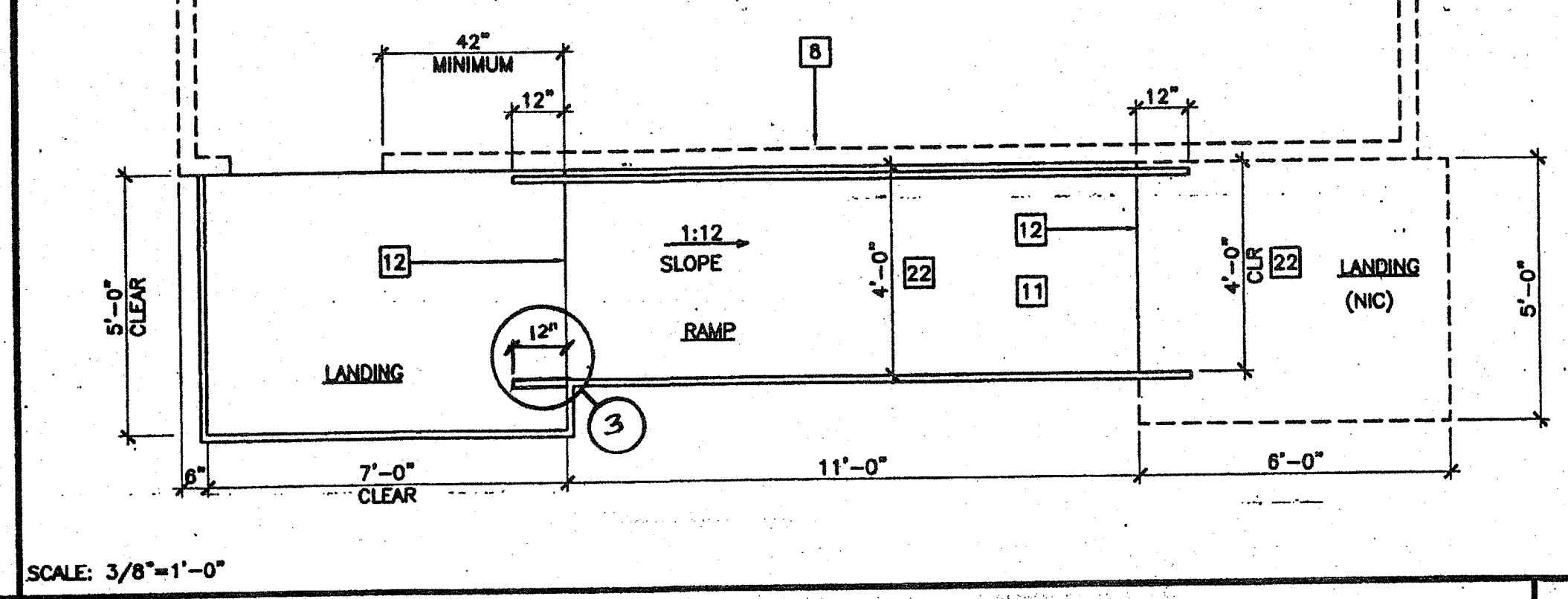

RAMP AND LANDING AT BUILDING 2

SCALE: 3/8"=1'-0"

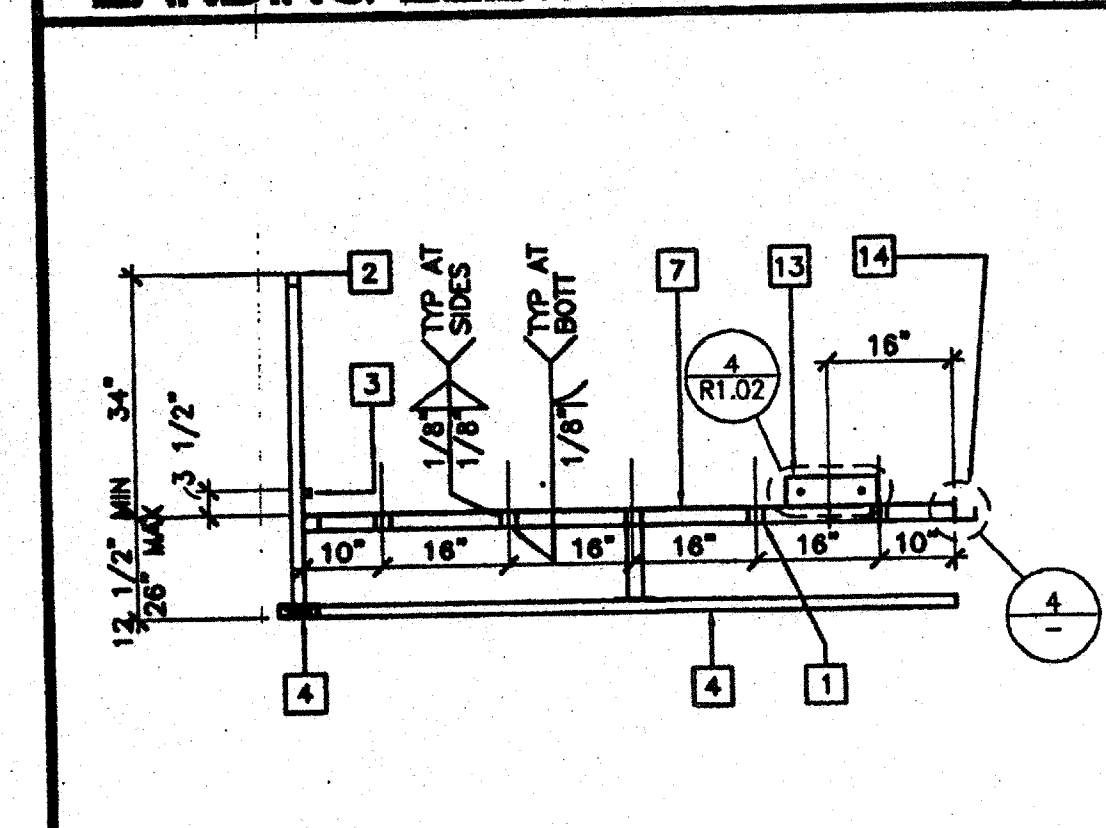

SECTION AT LANDING 14

SCALE: NTS

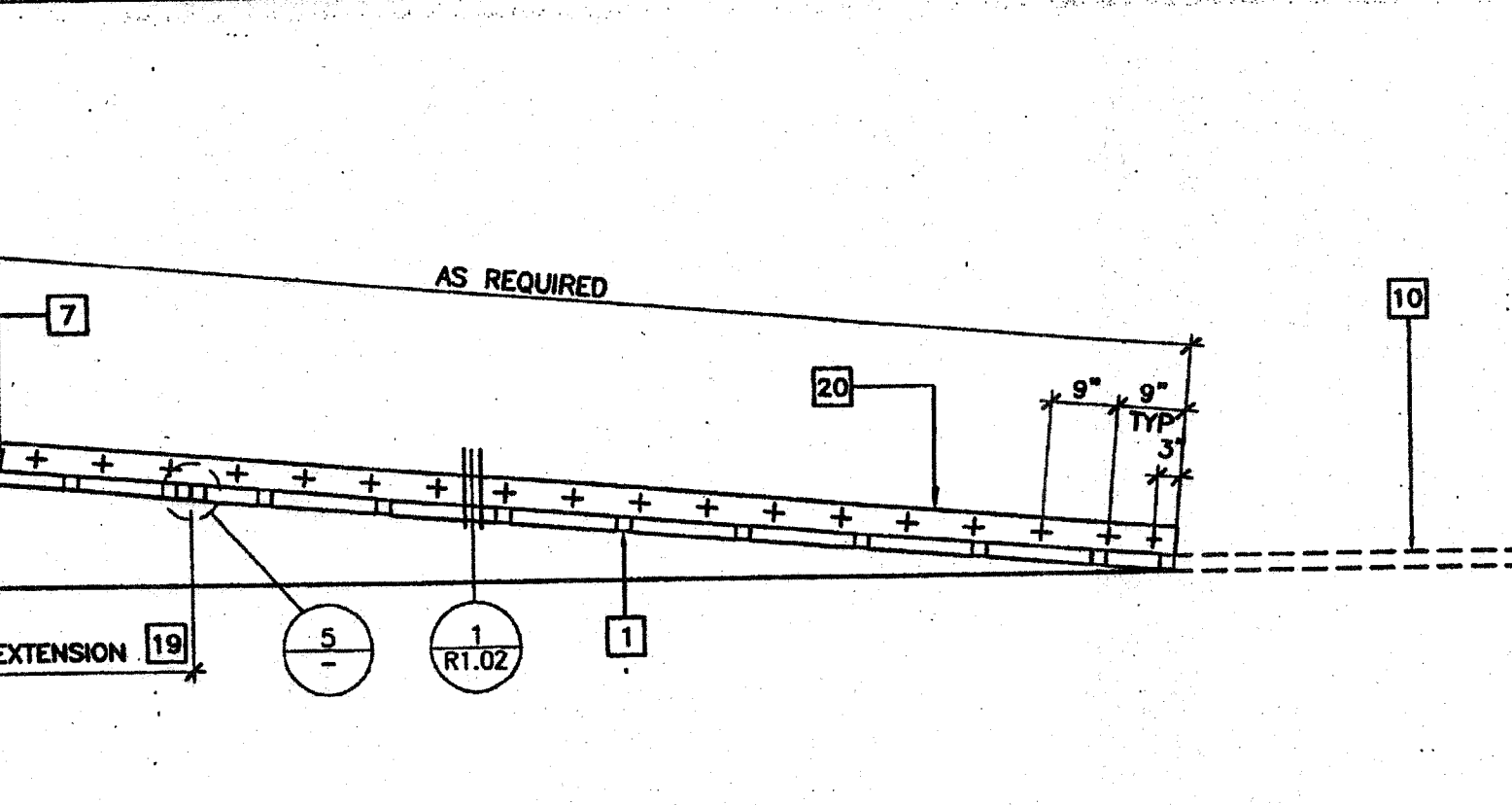

LONGITUDINAL SECTION AT RAMP 9

SCALE: NTS

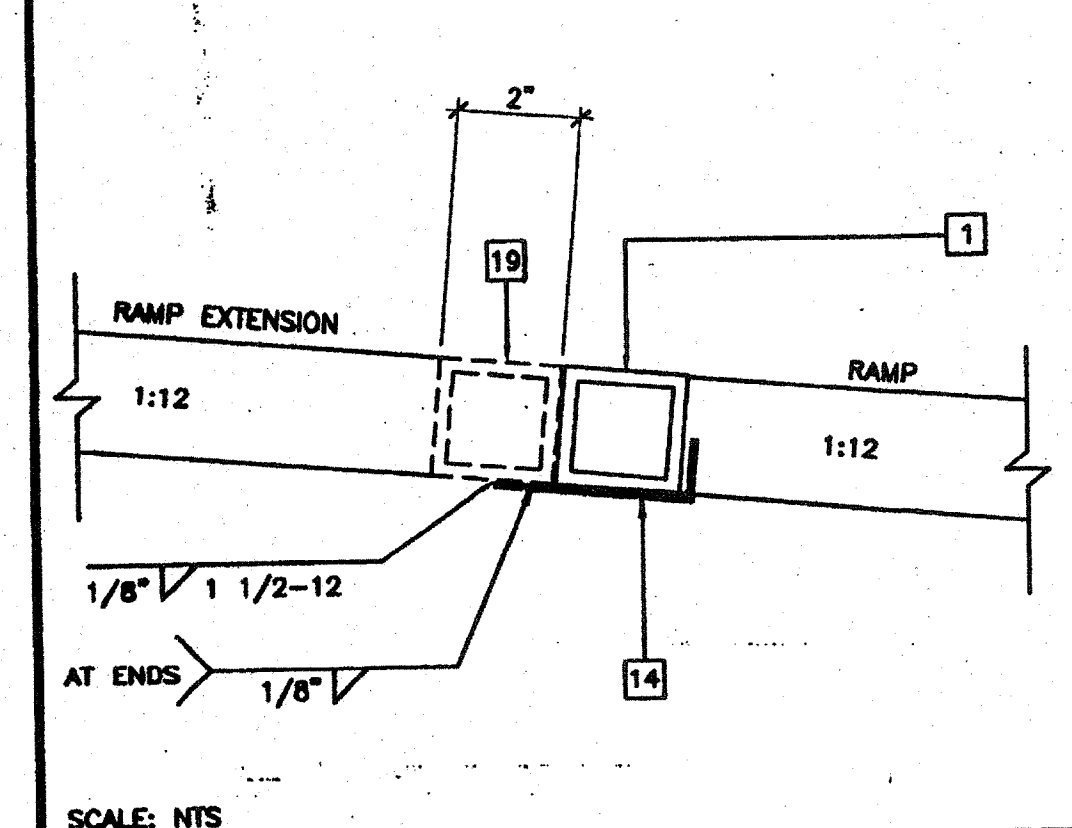

RAMP EXTENSION TO RAMP 5

SCALE: NTS

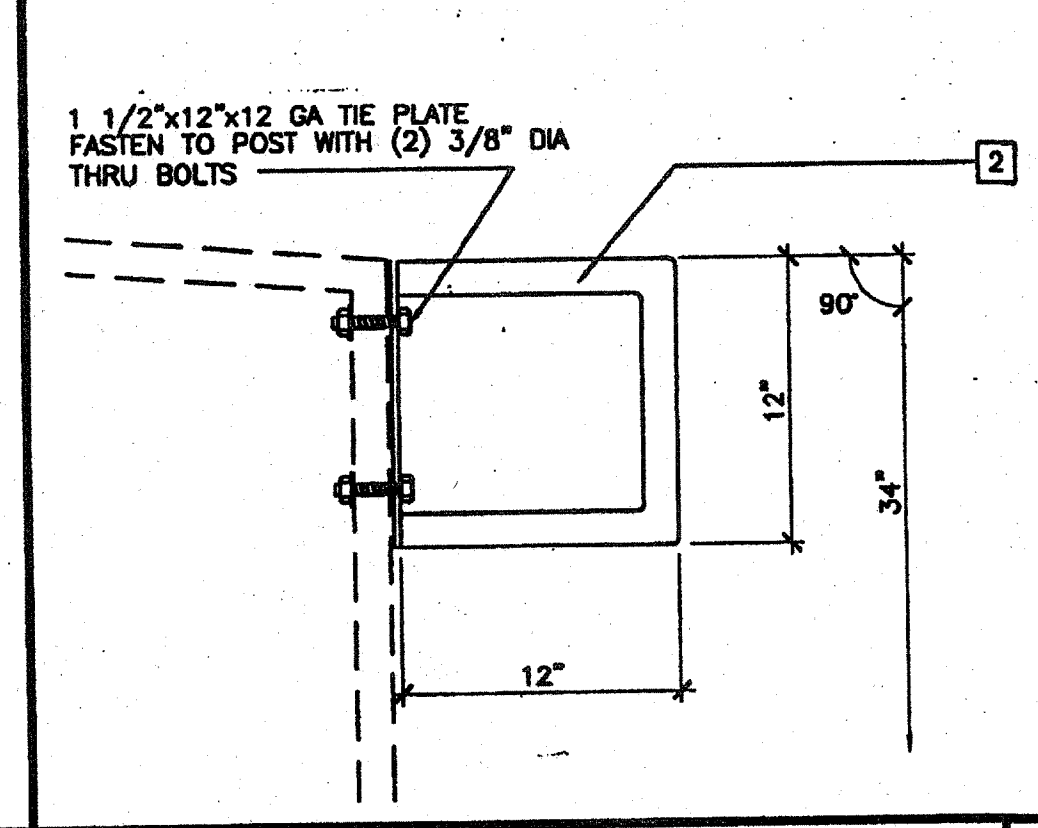

ALTERNATE GUARD RAIL EXTENSION 3

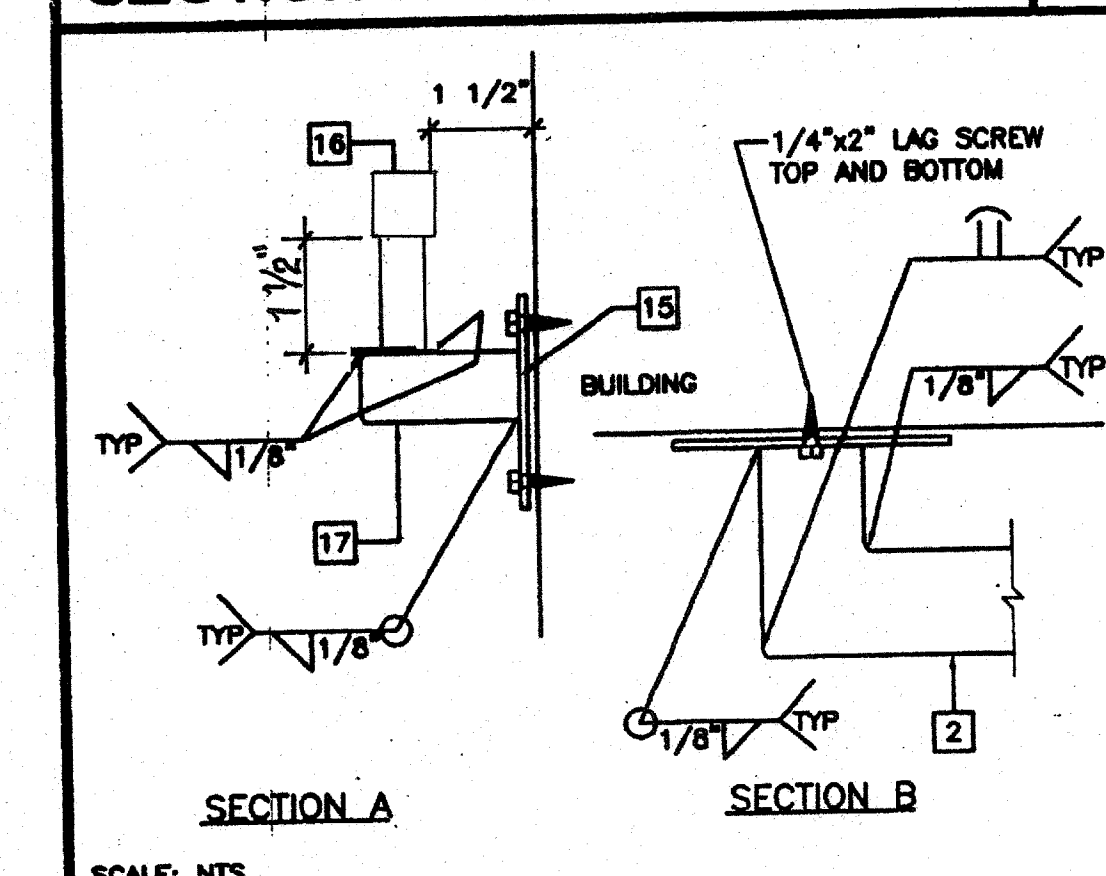

HANDRAIL CONNECTION 15

SCALE: NTS

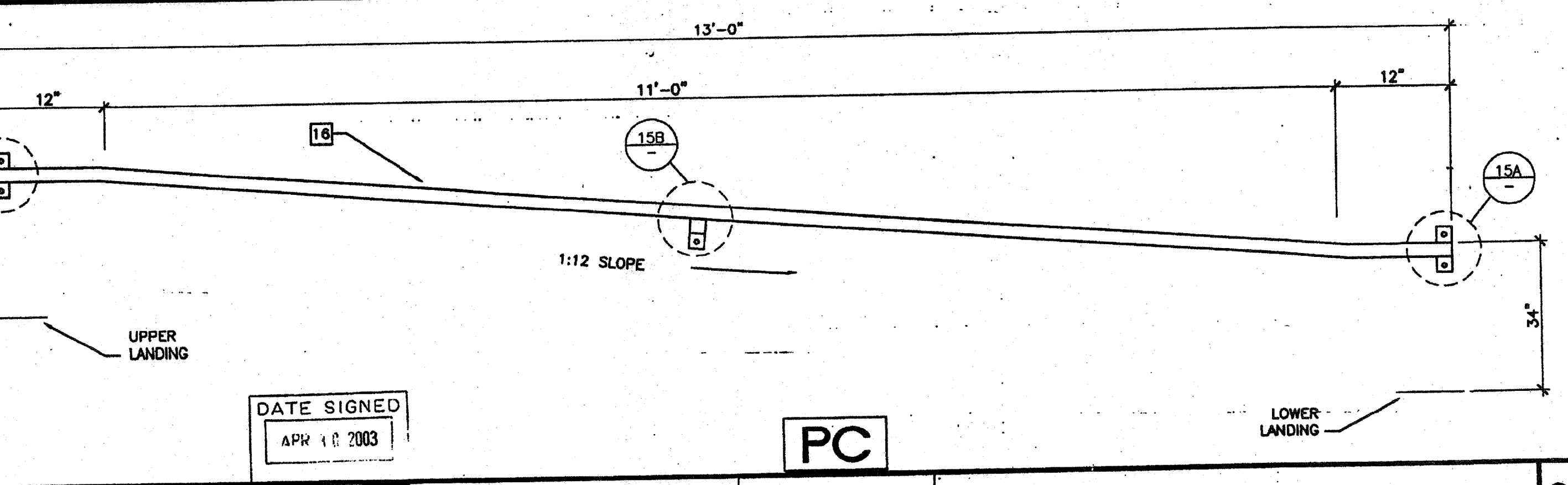

HANDRAIL ATTACHED TO BUILDING (OPTIONAL) 6

SCALE: NTS

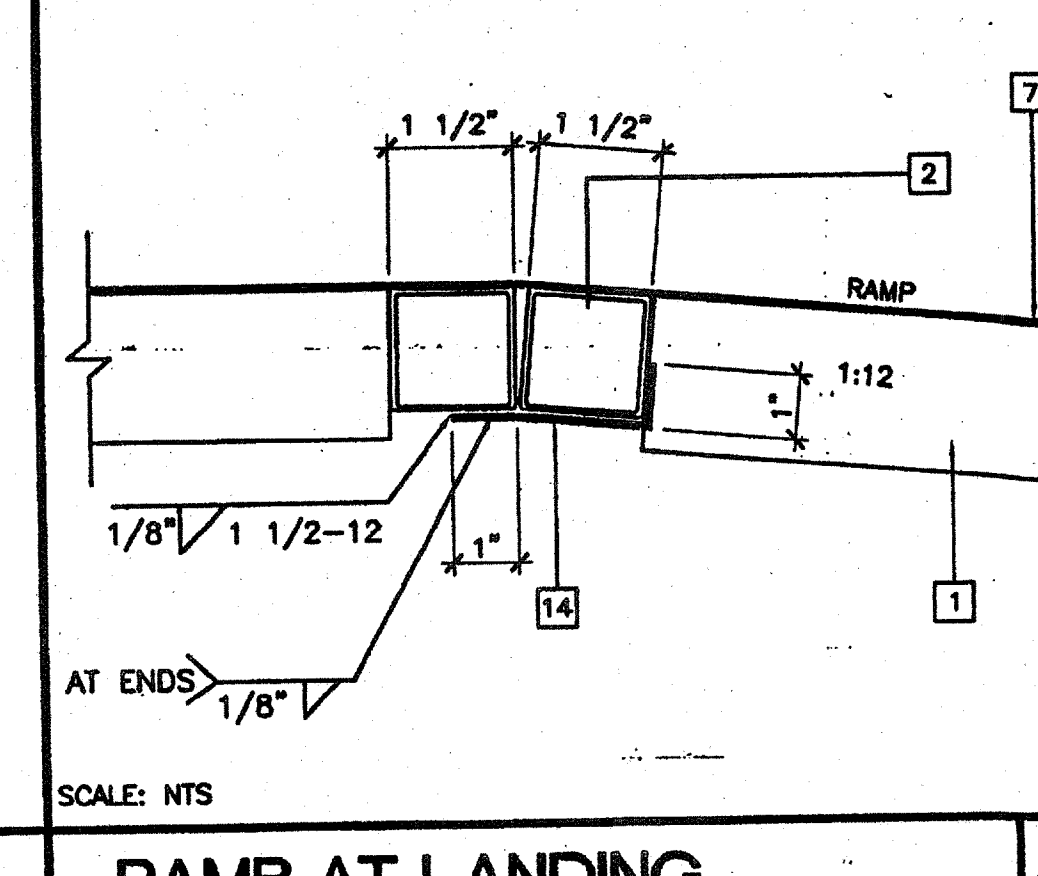

RAMP AT LANDING 4

SCALE: NTS

- NOTES**
1. RAMP: RAMP SHALL NOT SLOPE MORE THAN 1" IN 12"
  2. HANDRAILS: HANDRAILS AT BOTH SIDES OF RAMP AT 34" HEIGHT.
  3. SURFACE: LANDING AND RAMP TO HAVE NON-SLIP 0.7 MIN. COEFFICIENT OF FRICTION SURFACE AMCOR GRIP II AS MANUFACTURED BY AMERICAN CHEMICAL COMPANY (OR EQUAL)
  4. GROUNDING: PROVIDE GROUNDING OF RAMP TO BUILDING FRAME WITH #8 COPPER TO BOTH GROUND LUGS.
  5. ARCHITECT SITE/RAMP/LANDING PLANNING: DUE TO VARYING SITE CONDITIONS THE MAXIMUM HEIGHT OF FINISH FLOOR FROM GRADE IS 28". THEREFORE IT IS POSSIBLE THAT THE ACCESS RAMP ATTACHED TO THE BUILDING COULD BE 26'-0" AT A SLOPE OF 1:12. ARCHITECT MUST TAKE INTO ACCOUNT THAT THE RAMP SUPPLIED BY MODTECH INC. IS 11'-0" AT A SLOPE OF 1:12. THEREFORE THE ARCHITECT WILL HAVE TO DESIGN AND PROVIDE DETAILS OF RAMP EXTENSIONS AND BOTTOM LANDING DEPENDING ON PARTICULAR SITE CONDITIONS. IN NO WAY IS MODTECH INC RESPONSIBLE FOR ANY RAMP EXTENSION EXCEEDING THE ORIGINAL PLAN AS SHOWN ON THIS SHEET
  6. ALL 1 1/4" AND 1 1/2" TUBE STEEL TO BE OF ASTM A500 GRADE A STEEL (Fy = 39 KSI)

IDENTIFICATION STAMP  
DIV. OF THE STATE ARCHITECT  
OFFICE OF REGULATION SERVICES  
04 105299  
AC: FLS  
DATE: MAY 22 2003

**REVISIONS**

AGENCY TRACKING NO. 62231-2-67  
FILE NO.: 15-6  
IDENTIFICATION STAMP  
DIV. OF THE STATE ARCHITECT  
03118255  
AC: FLS  
DATE: JUL 11 2003

PC Professional of Record Seal  
Architects Seal  
DATE SIGNED  
APR 18 2003

PC  
CBC 2001  
LICENSE EXPIRES 6-30-2004

IDENTIFICATION STAMP  
DIV. OF THE STATE ARCHITECT  
OFFICE OF REGULATION SERVICES  
PC-04  
104801  
AC: FLS  
DATE: 5/11/03

**MODTECH™**  
2830 BARRETT AVENUE PH (909) 943-4014  
PERRIS, CALIF. 92571 FAX (909) 940-0427

PROJECT NUMBER: © MODTECH, INC. 2002  
DRAWN BY: STKP-70  
DATE: 05-22-03  
CLASS LEASING INC STOCKPILE # 70  
100-24 x 40 CLASSROOM BUILDINGS  
4012-125 05-22-2003 80 MPH  
CHECKED BY: DATE:  
MODTECH Index No.  
**4 FOOT RAMP AND LANDING PLAN R1.01**