

A WATER SUPPLY ISOMETRIC
P1 NO SCALE

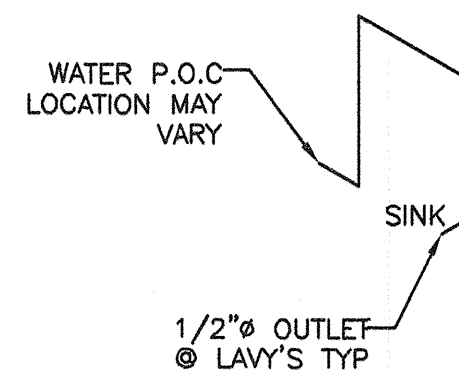

A.1 WATER SUPPLY ISOMETRIC
P1 NO SCALE

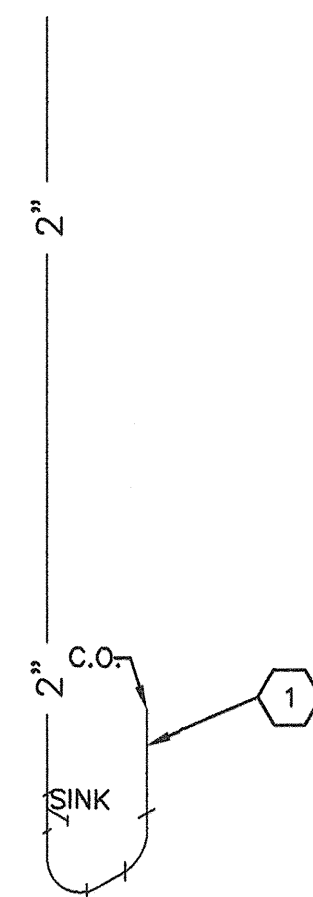

B WASTE ISOMETRIC
P1 NO SCALE

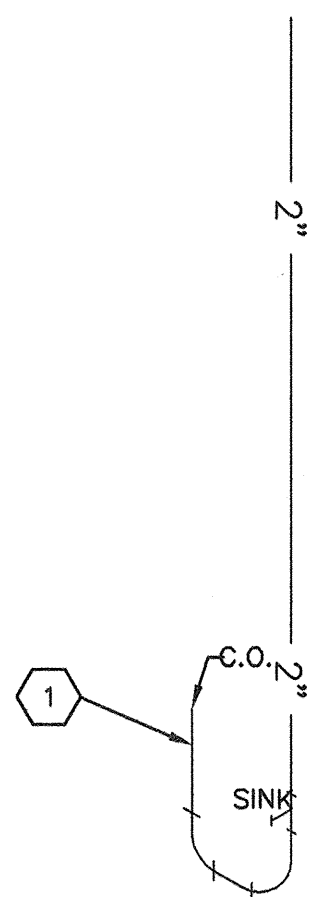

B.1 WASTE ISOMETRIC
P1 NO SCALE

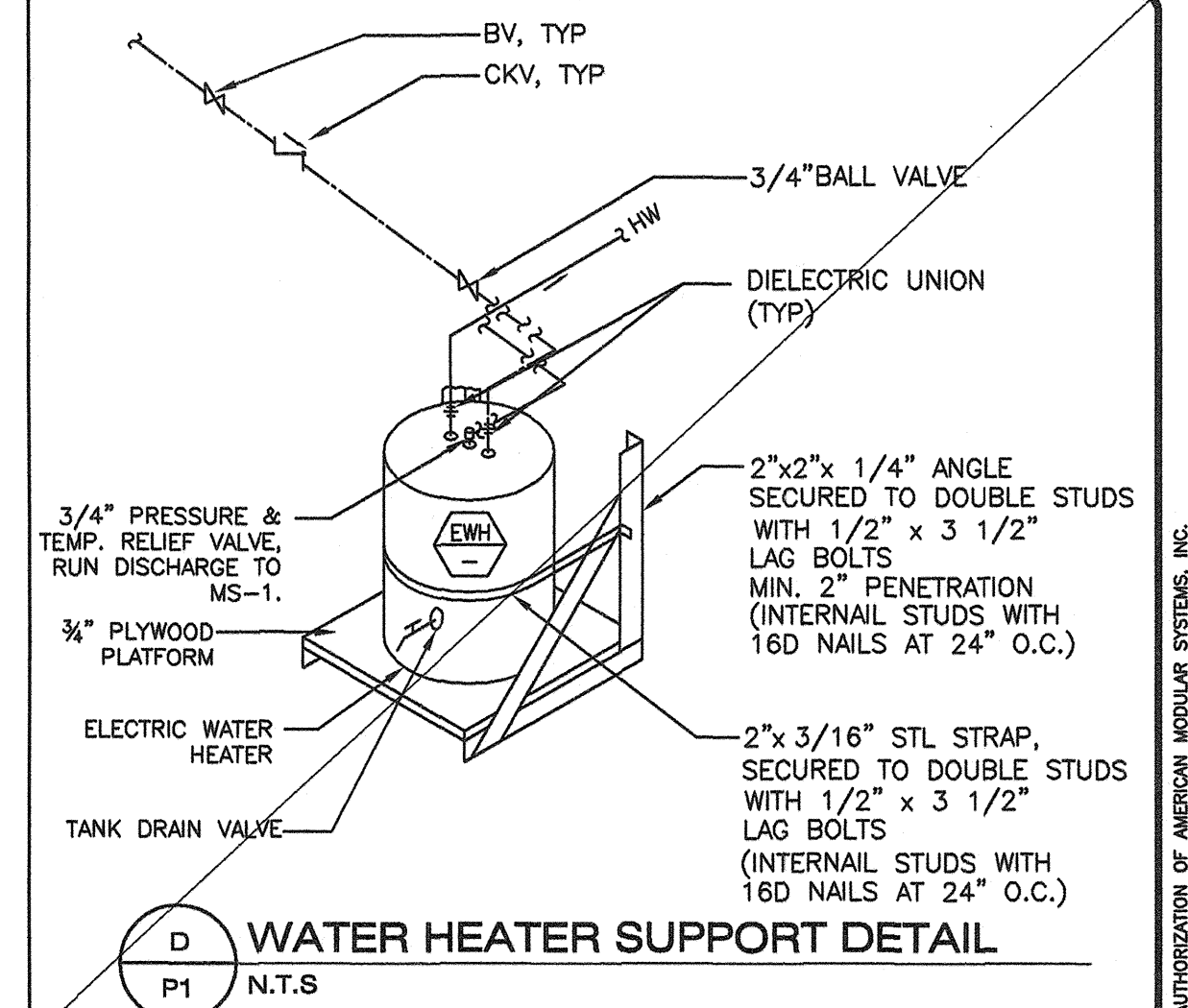

D WATER HEATER SUPPORT DETAIL
P1 N.T.S

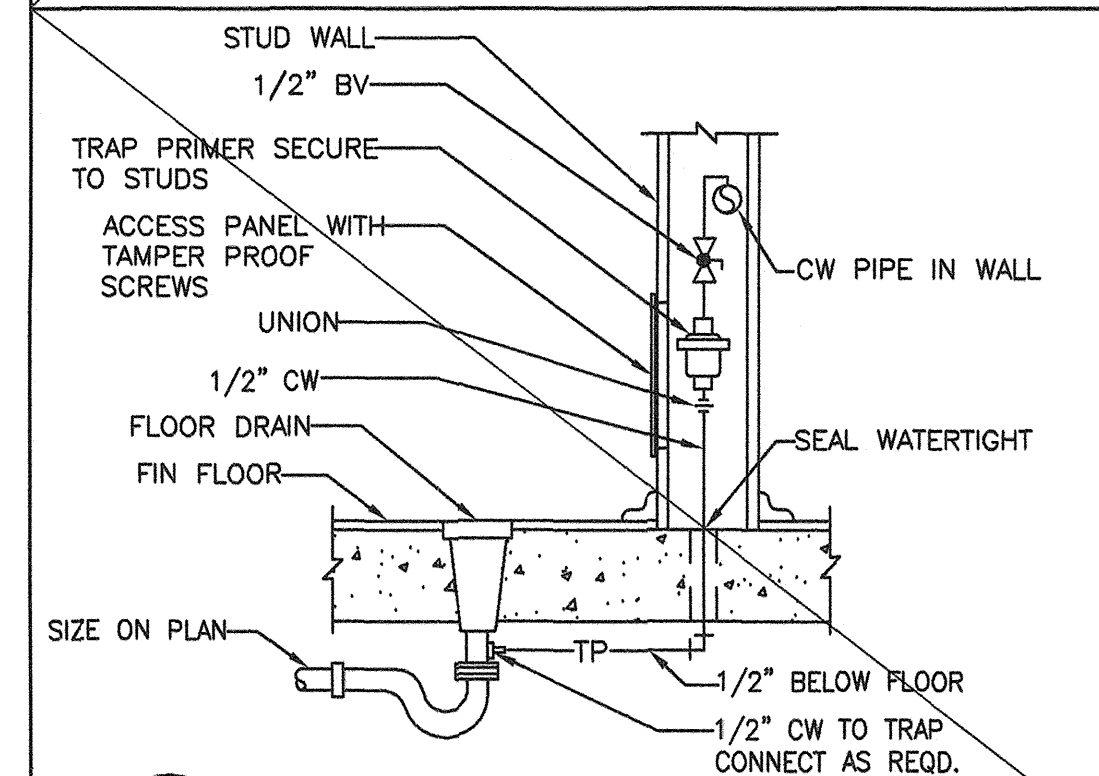

E TRAP PRIMER DETAIL
P1 N.T.S

NOTE:
INSULATE HOT WATER SUPPLY AND DRAIN PIPING AT ACCESSIBLE LAVATORIES WITH HAND-LAV GUARD KITS AS MANUFACTURED BY "TRUEBRO" INC.
FAUCET SHALL BE FLOW RESTRICTED TO MATCH FLOW CONTROL

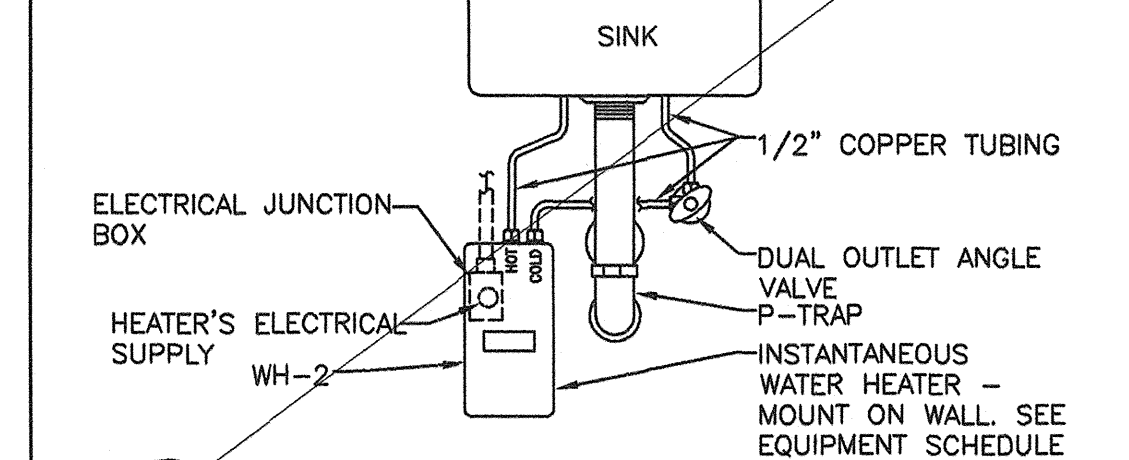

F INSTANT WATER HEATER DETAIL
P1 N.T.S

SHEET NOTES

- DWV PIPING SHALL BE ABS PLASTIC
- COLD WATER SUPPLY SHALL BE TYPE L COPPER
- DWV PIPING:
MIN SLOPE 1/4" PER FOOT
MAY SLOPE 4" CI @ 1/8" PER FOOT
VENTS SHALL TERMINATE NOT LESS THAN 10 FEET FROM OR AT LEAST 3 FT. ABOVE ANY WINDOW, DOOR, AIR INTAKE OR VENT SHAFT, NOR LESS THAN 3FT. IN EVERY DIRECTION FROM ANY LOT LINE, ALLEY AND STREET EXCEPTED; EXTEND 6" ABOVE THE ROOF

BASED ON PC# 02-109685

REVISIONS		
NO	DATE	DESCRIPTION

DATE: 08/12/10
SCALE: NOTED
DRAWN BY: RS
SERIAL NO.:

CUSTOMER:
BAKERSFIELD CITY SCHOOLS
PIONEER DRIVE ELEMENTARY SCHOOL

2:12 PITCHED ROOF 24' x 40' RELOCATABLE BUILDINGS
ISOMETRIC PLANS & DETAILS

APPROVALS:

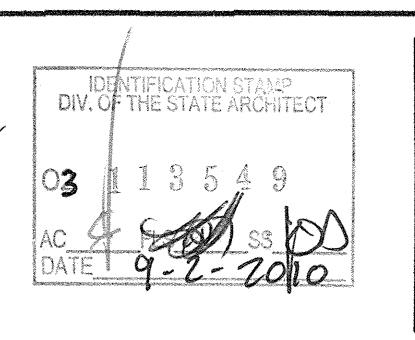
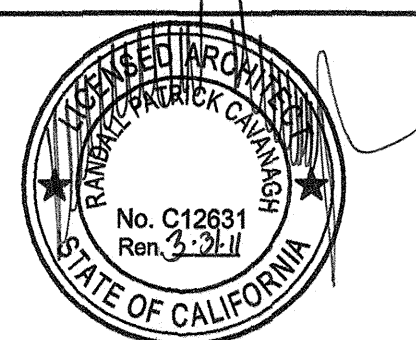

IDENTIFICATION STAMP
DIV. OF THE STATE ARCHITECT
OFFICE OF REGULATION SERVICES
AC: FLS: SS
DATE:

PROJECT NO.
P1-C

THESE DRAWINGS AND SPECIFICATIONS ARE THE PROPERTY OF AMERICAN MODULAR SYSTEMS, INC. AND ARE NOT TO BE REPRODUCED, CHANGED OR COPIED IN ANY FORM OR MANNER, NOR ARE THEY TO BE ASSIGNED TO ANY THIRD PARTY WITHOUT THE WRITTEN AUTHORIZATION OF AMERICAN MODULAR SYSTEMS, INC.