

LANDING FRAME 12

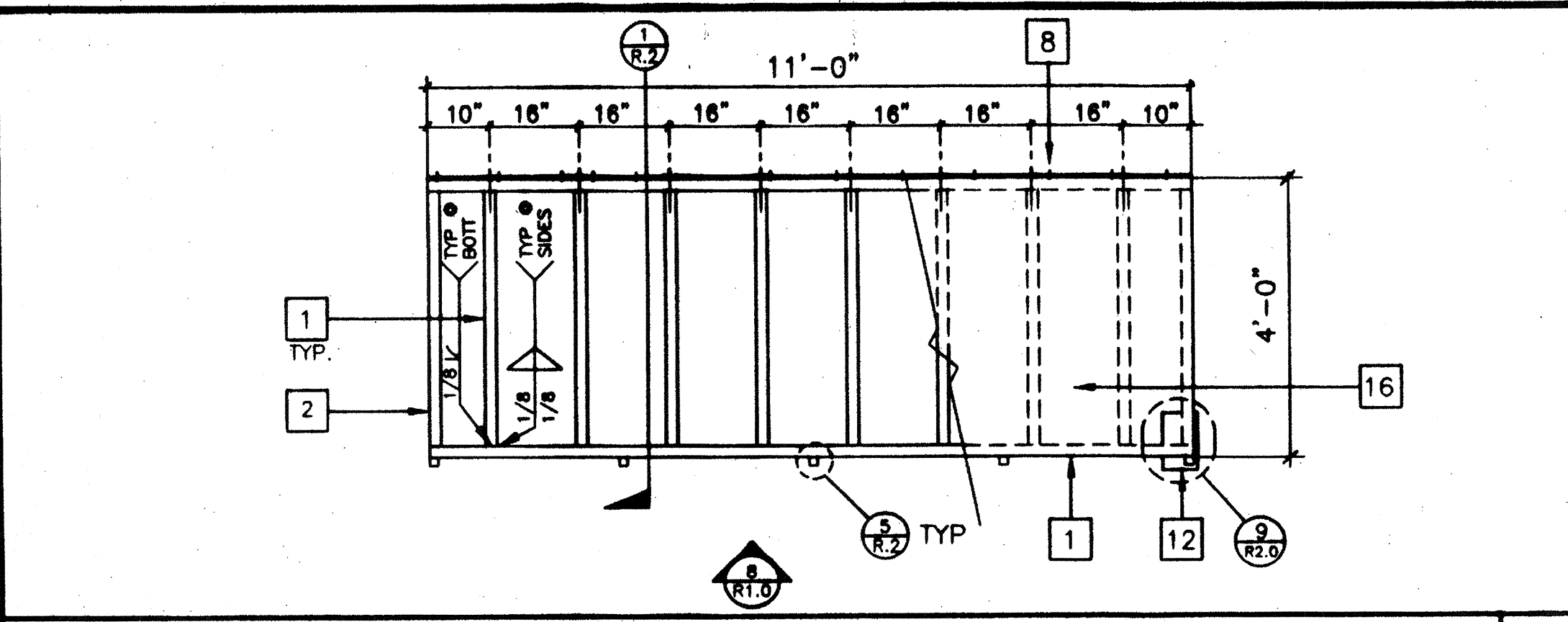

RAMP FRAME 7

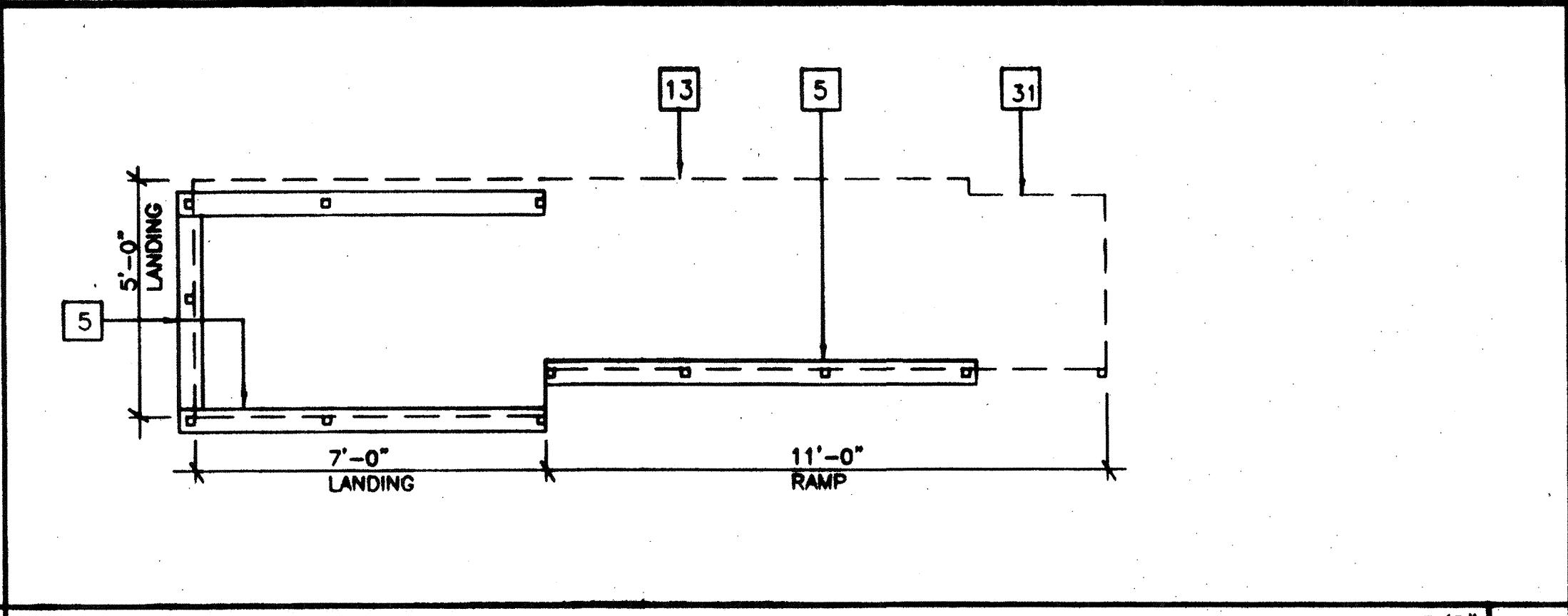

SILL PLAN FOR RAMP AND LANDING 3/8" 1

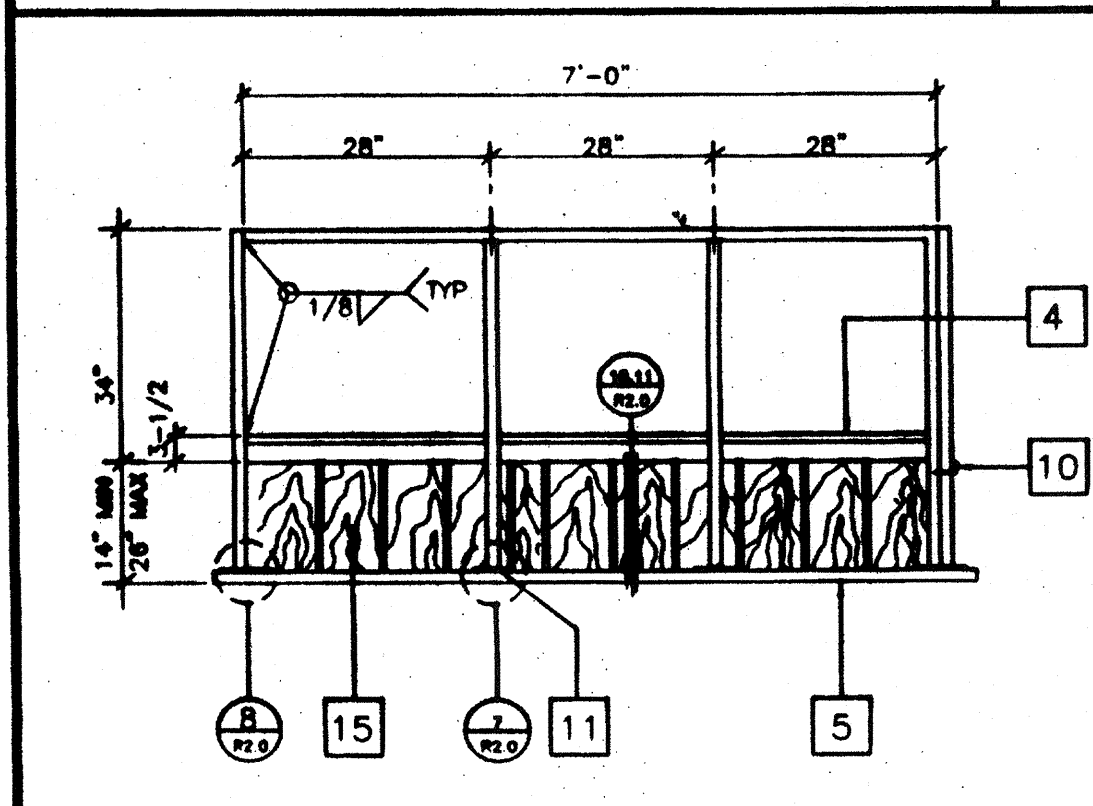

LANDING ELEVATION 13

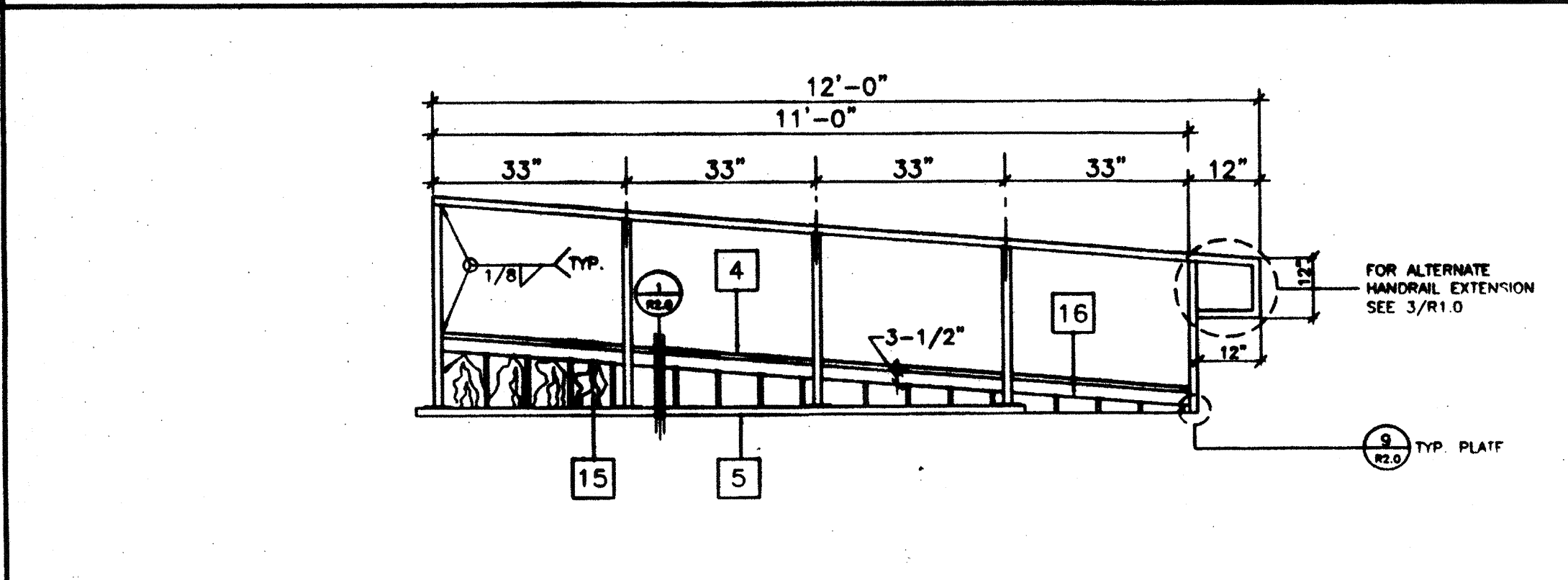

RAMP ELEVATION 13

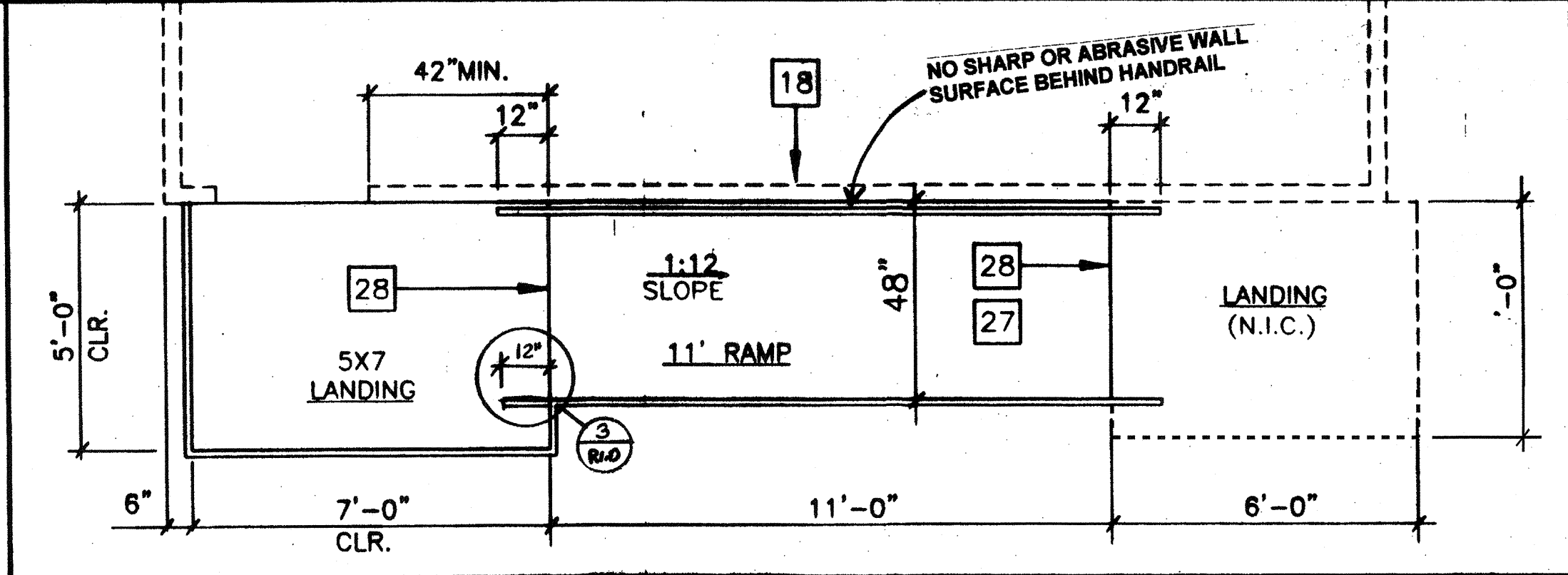

RAMP AND LANDING AT BUILDING 3/8" 2

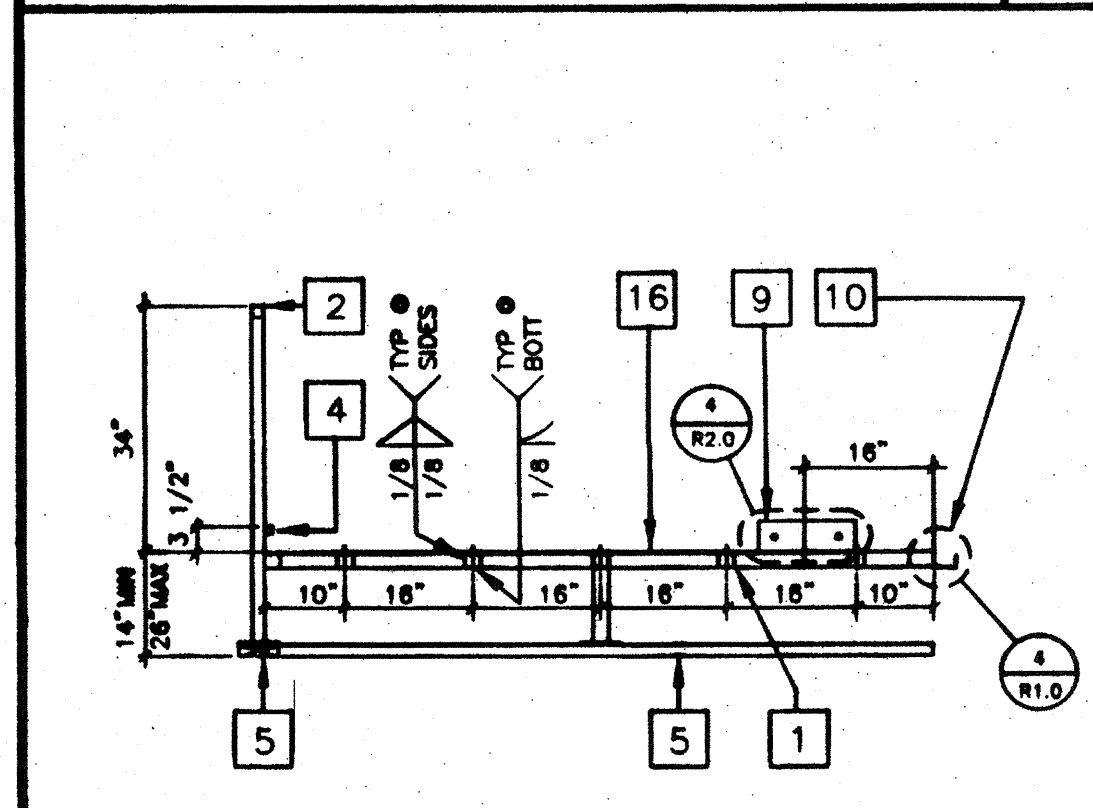

LONG. SECTION @ LANDING 14

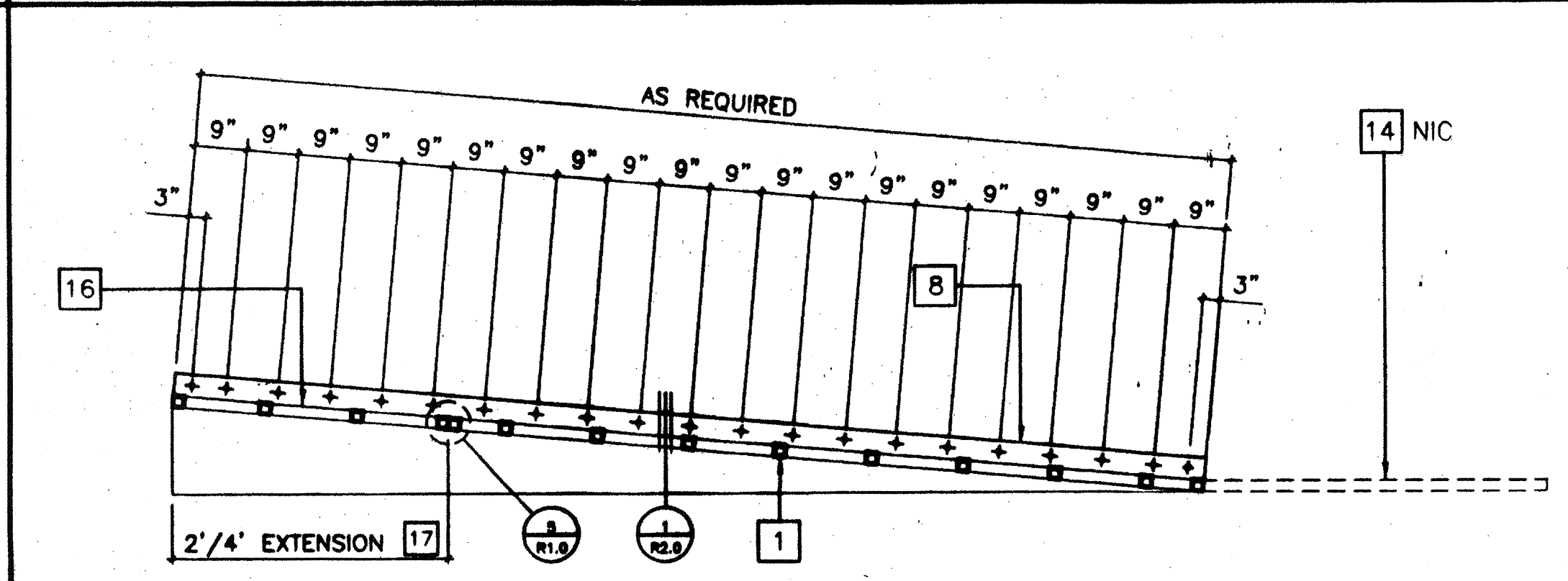

LONGITUDINAL SECTION @ RAMP 9

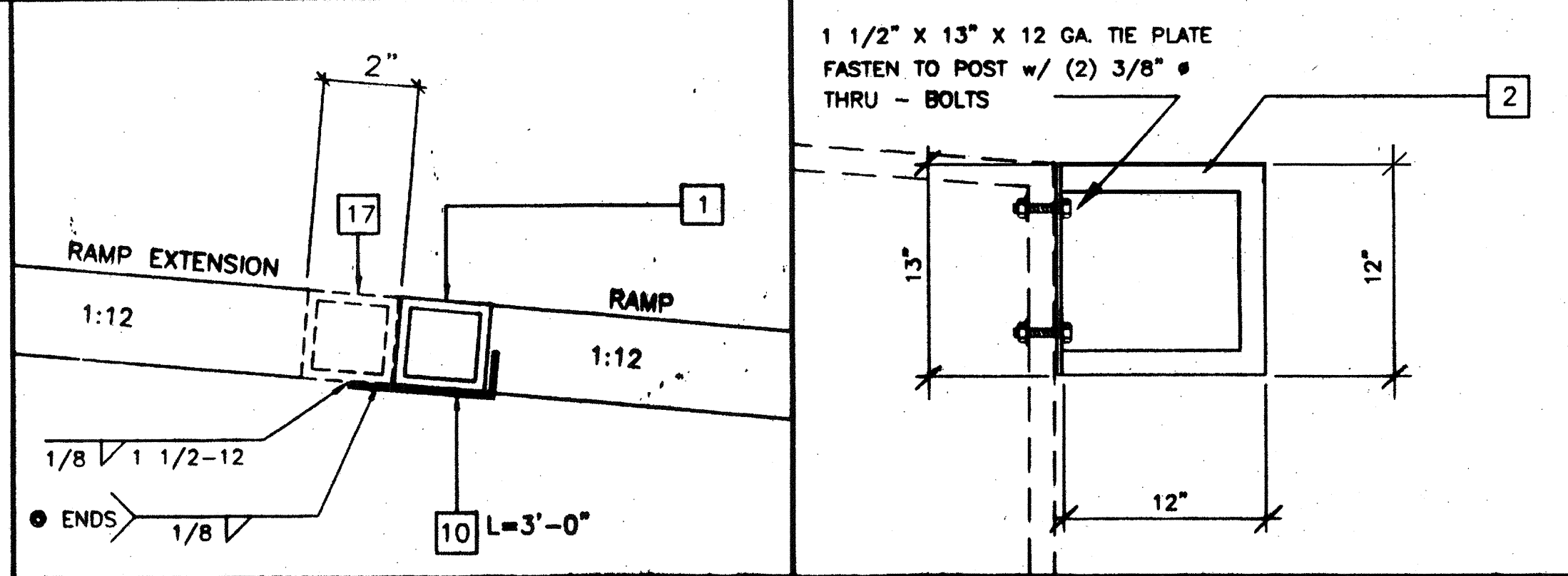

RAMP EXTENSION TO RAMP 5

- ### KEY NOTES
- TS 2" x 2" x 14ga
  - TS 1 1/2" x 1 1/2" x 14ga (Fy = 39KSI)
  - TS 1" x 1" x 16ga WHEELCHAIR GUIDE
  - 2 x 6 FT SILL PLATE
  - 6" x 10ga CONT. PLATE W/ 1/4" X 2" TEK SCREWS @ 9" OC INTO WOOD OR FOUND. BLOCKS OR #14 X 2" TEK SCREWS INTO STEEL @ 9" OC
  - 6" x 12" x 10ga PLATE W/ 2-1/4" X 3" LAGS TO STRUCTURAL FRAME OF BUILDING
  - 3" x 1" x 3'-0" x 10ga BENT PLATE
  - 2" x 4" x 12ga BASE PLATE W/ 2-1/4" X 1" LAGS
  - 6" x 10" x 12ga BASE PLATE @ RAMP TOE
  - LINE OF RAMP/LANDING ABOVE
  - LOWER LANDING BY DISTRICT
  - SKIRTING: PLYWOOD TO MATCH BUILDING SIDING. BLOCK ALL EDGES. ATTACH W/ 8d @ 6" OC EDGES AND 12" OC FIELD. AT EDGE CONNECTION TO T.S. USE #14 X 2" TEK SCREWS @ 6" OC
  - 12ga METAL DECK: NON-SLIP SURFACE. DESIGN COEFFICIENT OF FRICTION GREATER THAN 0.6. MAINTAINABLE FOR 1 YR. RAMP EXTENSION FRAME.
  - EXISTING BUILDING.
  - RAMP BY MODTECH
  - FLUSH TRANSITION
  - NOTCH BOTTOM PLATE (MUD SILL) AS REQUIRED TO CLEAR RAMP TOE. MAX NOTCH 1 1/2" X 4'-0" LONG.
  - TS 1" x 1" x 18ga

FILE #15-6  
 IDENTIFICATION STAMP  
 DIV. OF THE STATE ARCHITECT  
 OFFICE OF REGULATION SERVICES  
 03-118271  
 AC. FLS. SS. CA  
 DATE MAR 14 2019  
 TRACKING #: 63321-294

IDENTIFICATION STAMP  
 DIV. OF THE STATE ARCHITECT  
 OFFICE OF REGULATION SERVICES  
 APPL 67533  
 AC. FLS. SS. CA  
 DATE MAR 11 1997

### NOTES

- RAMP: RAMPS SHALL NOT SLOPE MORE THAN 1" IN 12"
- HANDRAILS: HANDRAILS AT BOTH SIDES OF RAMP AT 34" HT.
- SURFACE: LANDING & RAMP TO HAVE NON SLIP SURFACE AMCOR GRIP II AS MANUFACTURED BY AMERICAN CHEMICAL COMPANY (OR EQUAL)
- GROUNDING: PROVIDE GROUNDING OF RAMP TO BLDG FRAM W/ #8 CU TO BOTH GROUND LUGS.
- ARCHITECT SITE / RAMP / LANDING PLANNING: DUE TO VARYING SITE CONDITIONS THE MAXIMUM HEIGHT OF FINISH FLOOR FROM GRADE IS 28" THEREFORE IT IS POSSIBLE THAT THE ACCESS RAMP ATTACHED TO THE BUILDING COULD BE 28'-0" AT A SLOPE OF 1:12 ARCHITECT MUST TAKE INTO ACCOUNT THAT THE RAMP SUPPLIED BY MODTECH INC. IS 11'-0" AT A SLOPE OF 1:12 THEREFORE THE ARCHITECT WILL HAVE TO DESIGN AND PROVIDE SUFFICIENT DETAILS OF RAMP EXTENSIONS AND BOTTOM LANDING DEPENDING ON PARTICULAR SITE CONDITIONS. IN NO WAY IS MODTECH INC. RESPONSIBLE FOR ANY RAMP EXTENSION EXCEEDING THE ORIGINAL PLAN AS SHOWN ON SHEET R-1.
- ALL 1 1/4" AND 1 1/2" TUBE STEEL TO BE OF ASTM A500 GRADE A STEEL (Fy = 39 KSI)

REVISIONS	Electrical Engineer's Seal	Mechanical Engineer's Seal	Structural Engineer's Seal	Architects Seal

Professional seals and stamps for Electrical, Mechanical, Structural, and Architectural disciplines. Includes a stamp for PC 266 dated JAN 21 1997.

**MODTECH INC.**  
 2830 BARRETT AVENUE  
 PERRIS, CALIF. 92572  
 PH (909) 943-4014  
 FAX (909) 940-0427

Job Number: PC 266 # 2510 # 2514 # 2515  
 © MODTECH, INC. 1997

drawn by: FWH  
 checked by: 11/98  
 date:  
 Modtech project no:  
 Modtech job no:  
**R1.0**

# RAMP / LANDING