

STEEL JOIST SCHEDULE

Member	Mark	Q Weld	Remarks
U.C.	T-9	3"	
L.C.	T-9	3"	
1-2	D-1	3"	
2-3	D-1	4"	
3-4	D-1	4"	
4-5	D-1	5"	
5-6	D-1	5 1/2"	
6-7	D-1	5 1/2"	
7-8	D-2	9"	
8-9	D-1	3"	
9-10	D-1	5 1/2"	
10-11	D-3	4 1/2"	
11-12	D-1	4 1/2"	
12-13	D-2	4 1/2"	
13-14	D-2	4 1/2"	
14-15	D-1	3"	
15-16	D-2	3"	
16-17	D-1	3"	
17-18	D-1	3"	
18-19	D-2	3"	
19-20	D-1	4 1/2"	
20-21	D-2	4 1/2"	
21-22	D-1	4 1/2"	
22-23	D-1	4 1/2"	
23-24	D-1	4 1/2"	
24-25	D-1	4 1/2"	

Use 1/2 of length of weld on side of stem of chord tee.

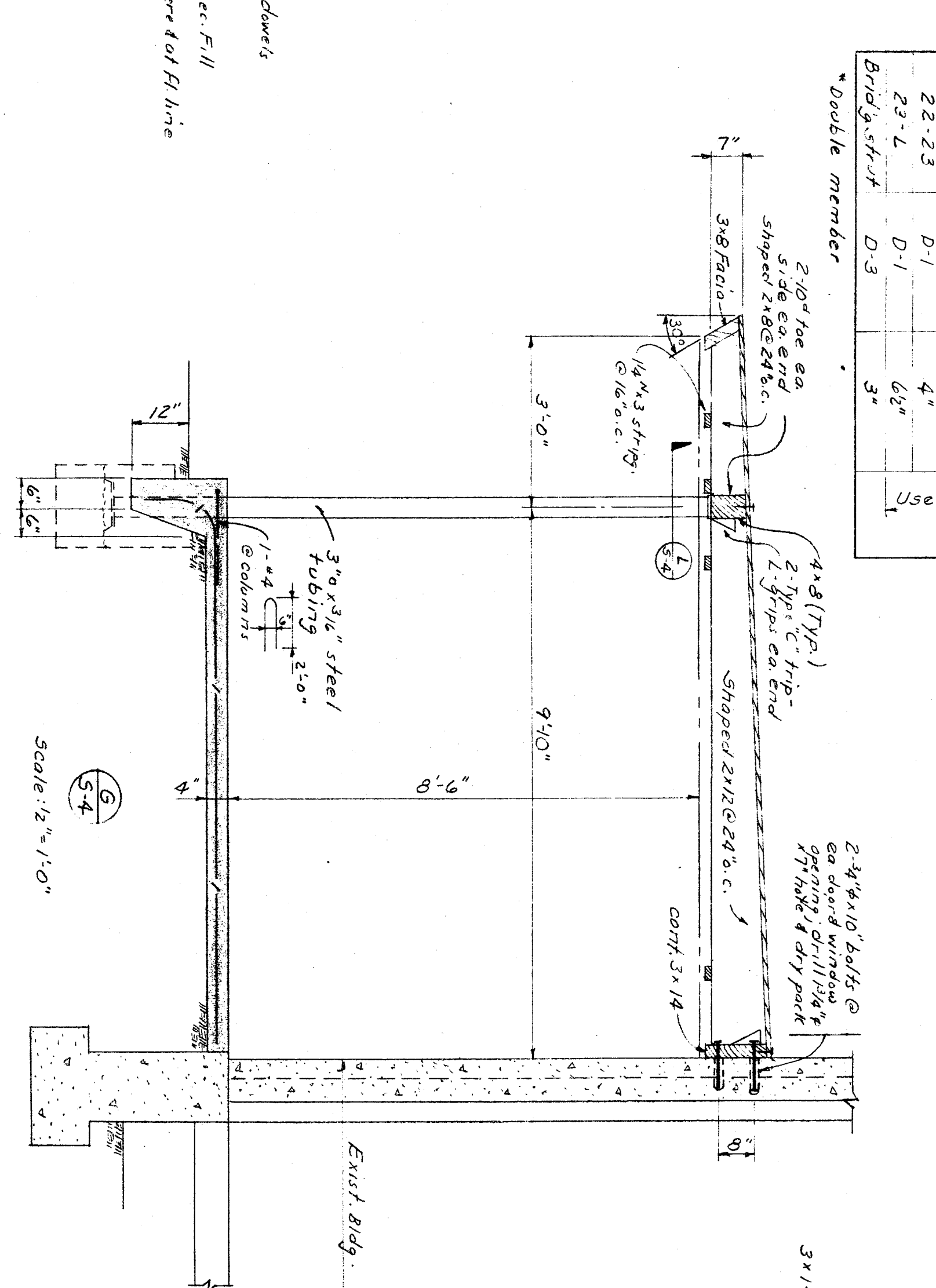
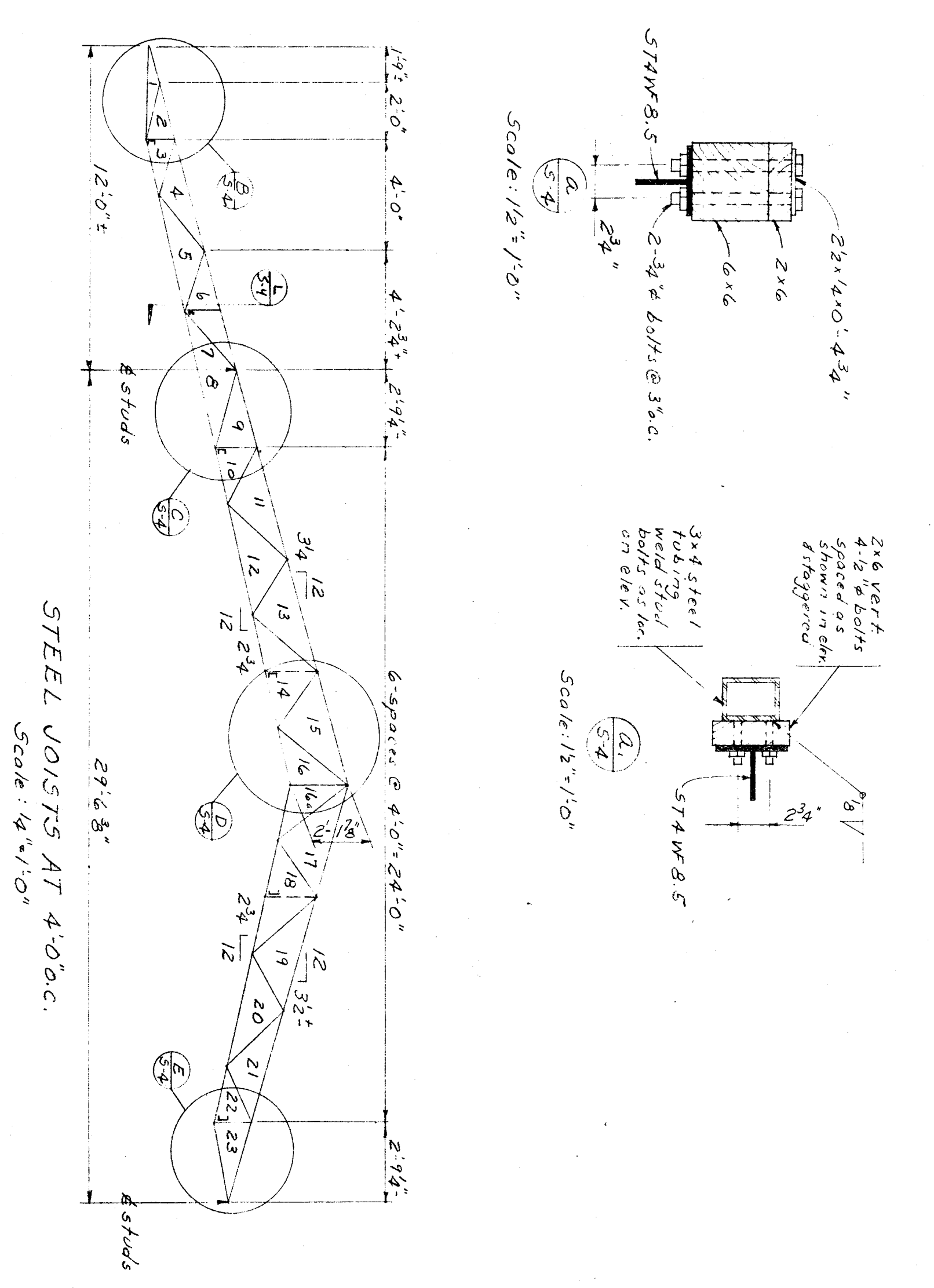

Chord member

Mark	Steel	Notes
D-1	4 x 1 1/2 x 1/8	3/4" lip of 2"
D-2	4 x 1 1/2 x 1/8	3/4" lip of 2"
D-3	4 x 1 1/2 x 1/8	3/4" lip of 2"

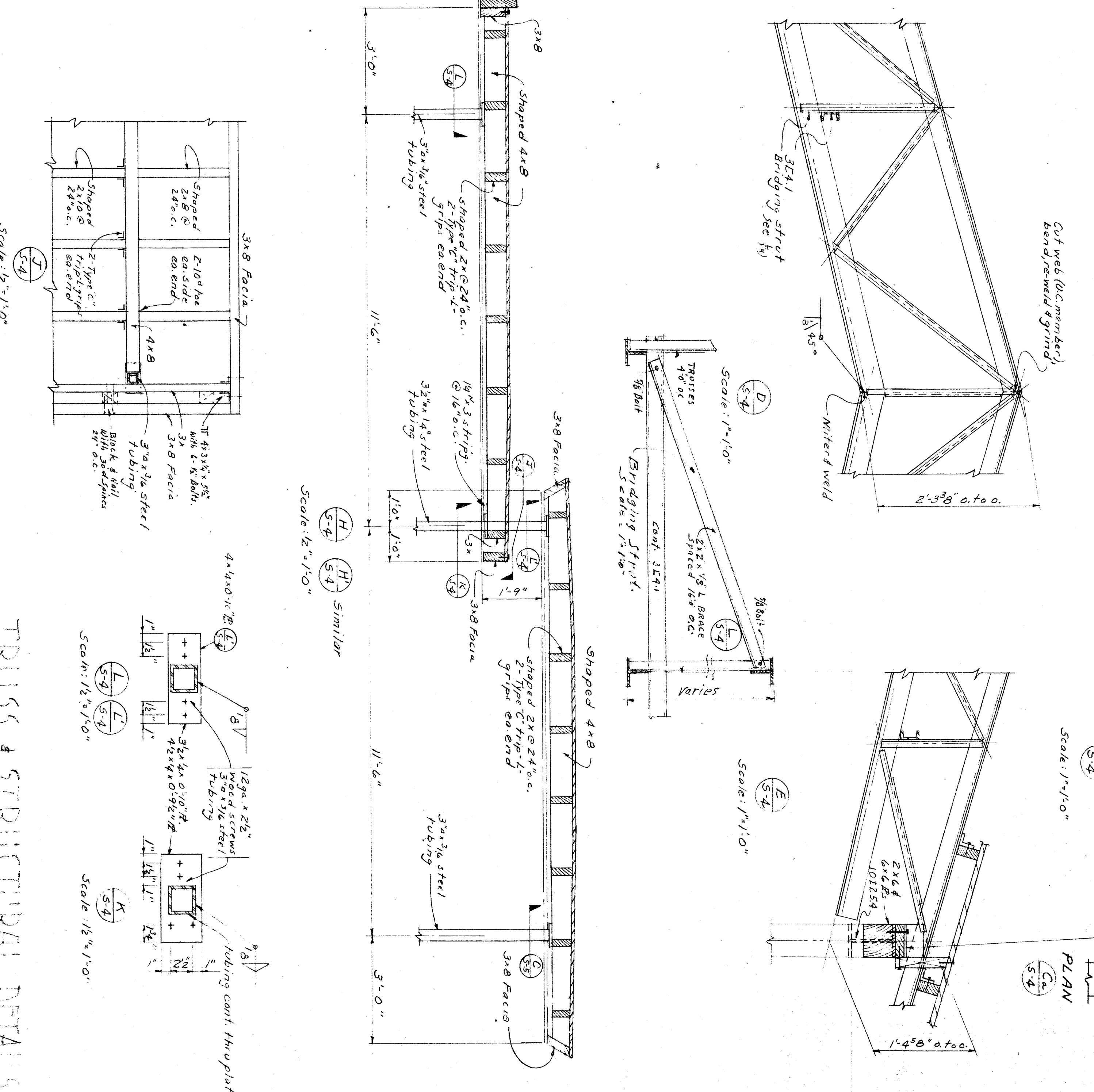
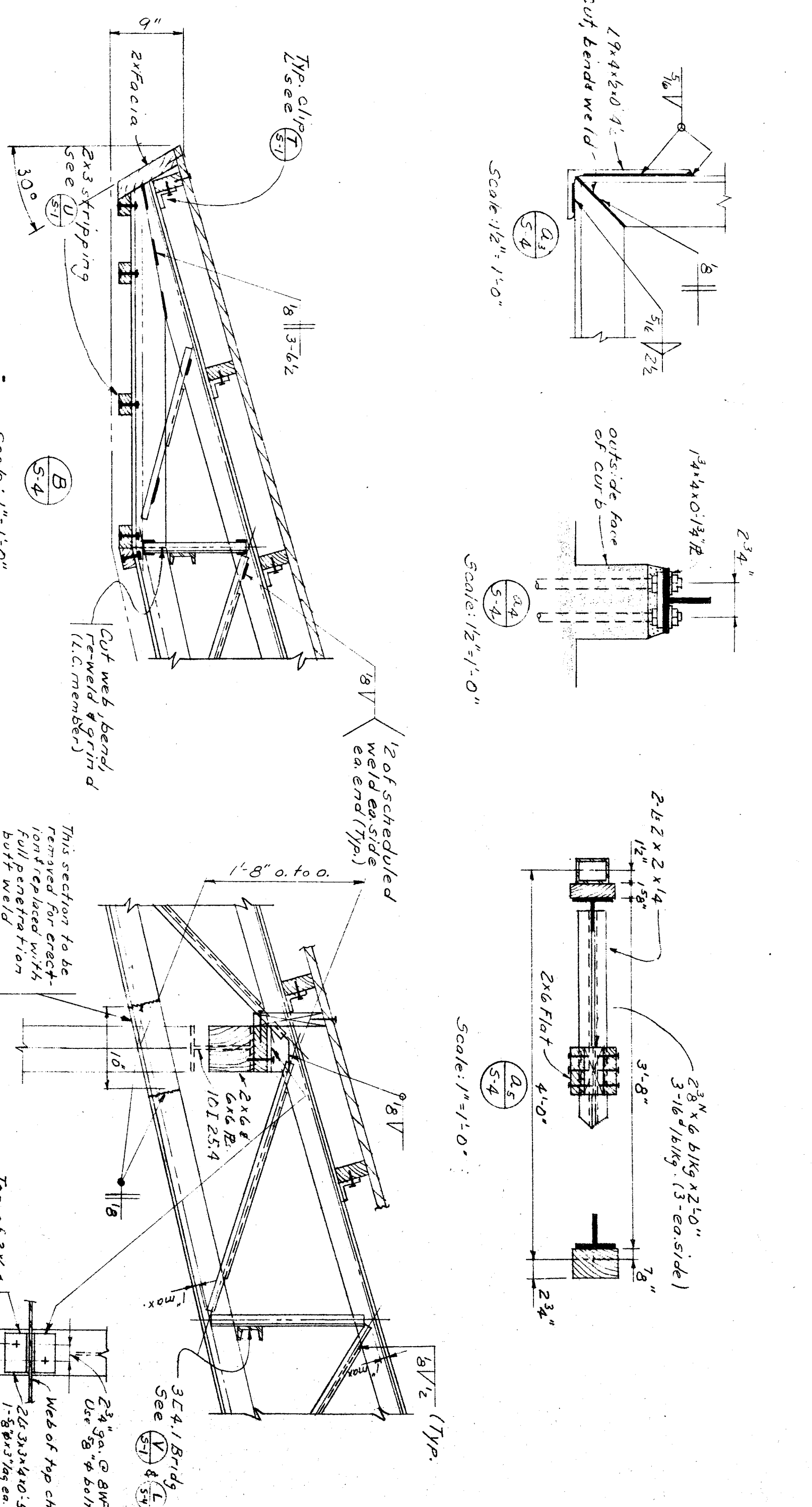

WILLIAMS & BIRD
STRUCTURAL ENGINEERS
1000 S. BAKERSFIELD CALIF.
BAKERSFIELD, CALIF.

OFFICE OF SUPERINTENDENT OF SCHOOLS
DEPARTMENT OF PUBLIC WORKS
DIVISION OF ARCHITECTURE

STATE OF CALIFORNIA
DEPARTMENT OF PUBLIC WORKS
DIVISION OF ARCHITECTURE

STATE OF CALIFORNIA
DEPARTMENT OF PUBLIC WORKS
DIVISION OF ARCHITECTURE

BAKERSFIELD CITY SCHOOLS
1000 S. BAKERSFIELD CALIF.
BAKERSFIELD, CALIF.

ADDITIONS & ALTERATIONS TO
HORACE MANN ELEM. SCHOOL
2710 NILES STREET
BAKERSFIELD, CALIFORNIA

ERNEST L. MCCOY ARCHITECT
PHOTOGRAPHY
CALIFORNIA

TRUSS & STRUCTURAL DETAILS