

THESE DRAWINGS AND ALL MATERIAL CONTAINED HEREIN ARE THE PROPERTY OF SILVERCREEK INDUSTRIES, INC (SCI INC) AND SHALL NOT BE REPRODUCED, COPIED OR OTHERWISE DISPOSED OF DIRECTLY OR INDIRECTLY AND SHALL NOT BE USED IN WHOLE OR IN PART TO ASSIST IN THE MAKING OF OR THE MAKING OF DRAWINGS, PRINTS, APPARATUS OR PARTS THEREOF WITHOUT THE FULL KNOWLEDGE AND WRITTEN CONSENT OF SCI INC. ALL PATENTABLE MATERIAL CONTAINED HEREIN AND ORIGINATING WITH SCI INC SHALL BE THE PROPERTY OF SCI INC.

SILVER CREEK INDUSTRIES, INC.



195 EAST MORGAN PERRIS, CALIFORNIA 92571
PHONE: 951-949-5393 FAX: 951-949-2211

PROJECT NAME:

CLASS LEASING CLASSROOM BLDG'S

SHEET TITLE:

RAMP DETAILS

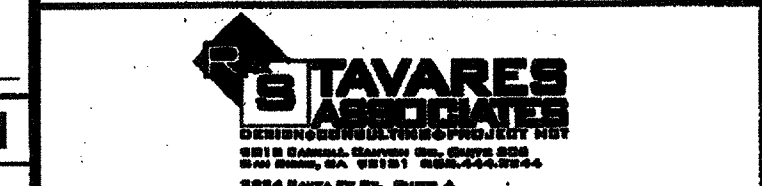

ARCHITECT OF RECORD
SUBMISSION DATE
12/23/2011

REGISTERED ARCHITECT
ROBERT A. MCKEY
DATE: AUG 28 2014

PROJECT SPECIFIC STATE AGENCY APPROVAL
IDENTIFICATION STAMP
DIV. OF THE STATE ARCHITECT
OFFICE OF REGULATION SERVICES
DATE: APR 04 2014

ORIGINAL PC STATE AGENCY APPROVAL
IDENTIFICATION STAMP
DIV. OF THE STATE ARCHITECT
OFFICE OF REGULATION SERVICES
DATE: DEC 2 2011

REVISIONS

SILVER CREEK INDUSTRIES
24' x 40' PC
PROJECT NO:
DRAWN BY: AS NOTED
SCALE:
DATE: 12-23-11
P.C. SHEET NUMBER

R-2.01 STKP 126

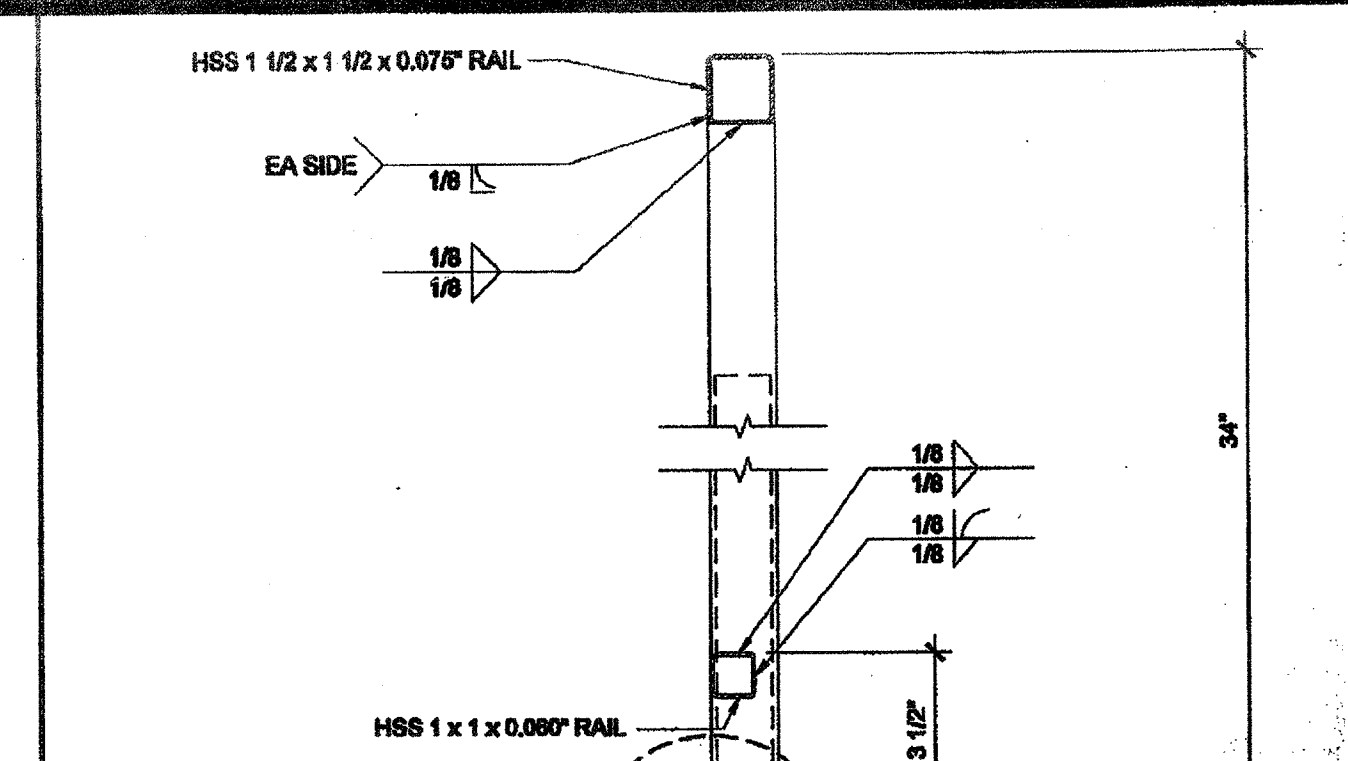

ADJUSTABLE LEG SCALE: 3\"/>

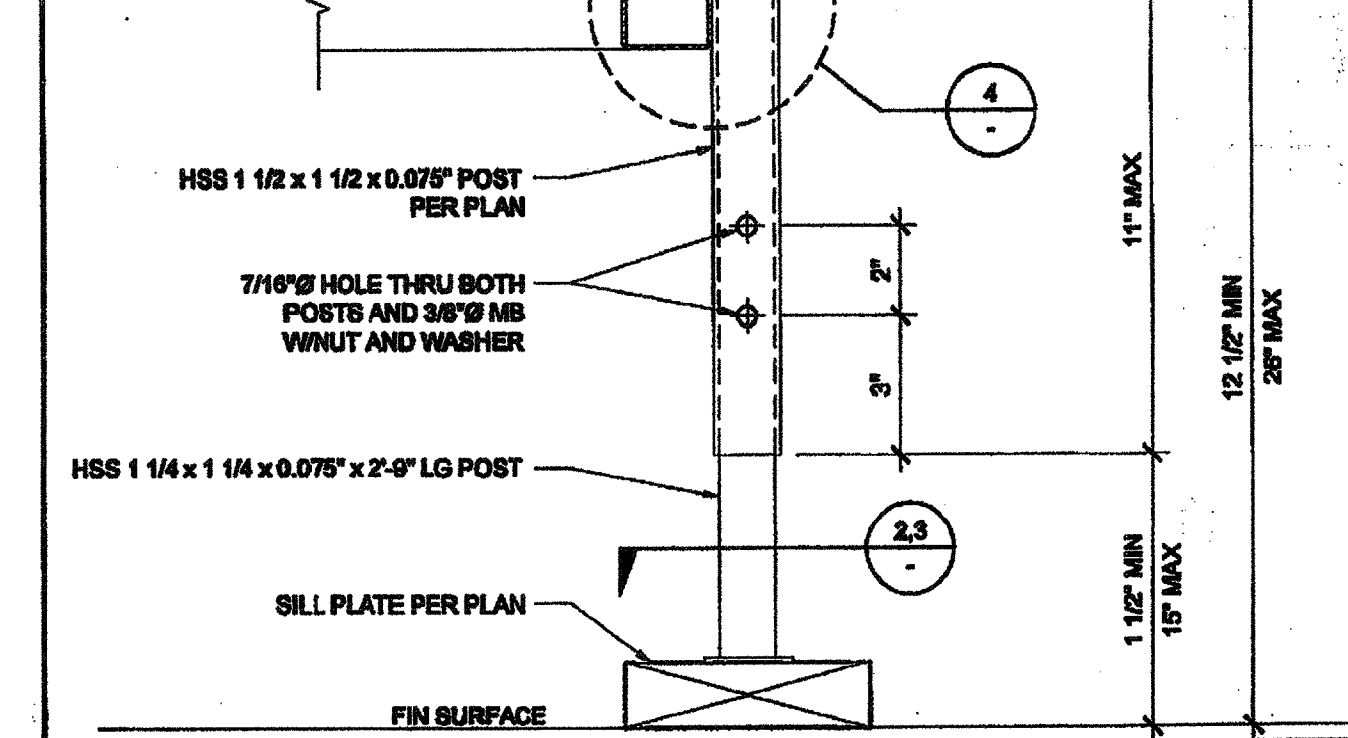

ADJUSTABLE LEG BASE PLATE SCALE: 3\"/>

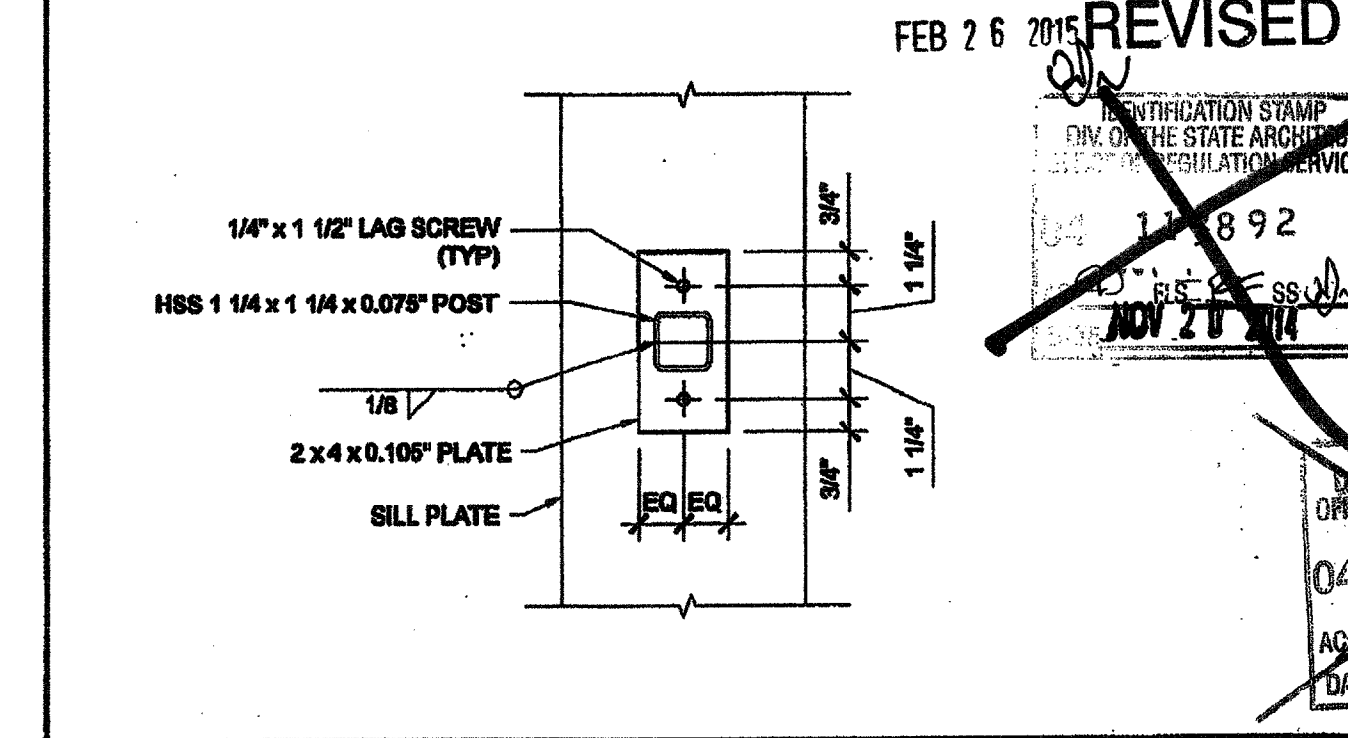

ADJUSTABLE LEG BASE PLATE SCALE: 3\"/>

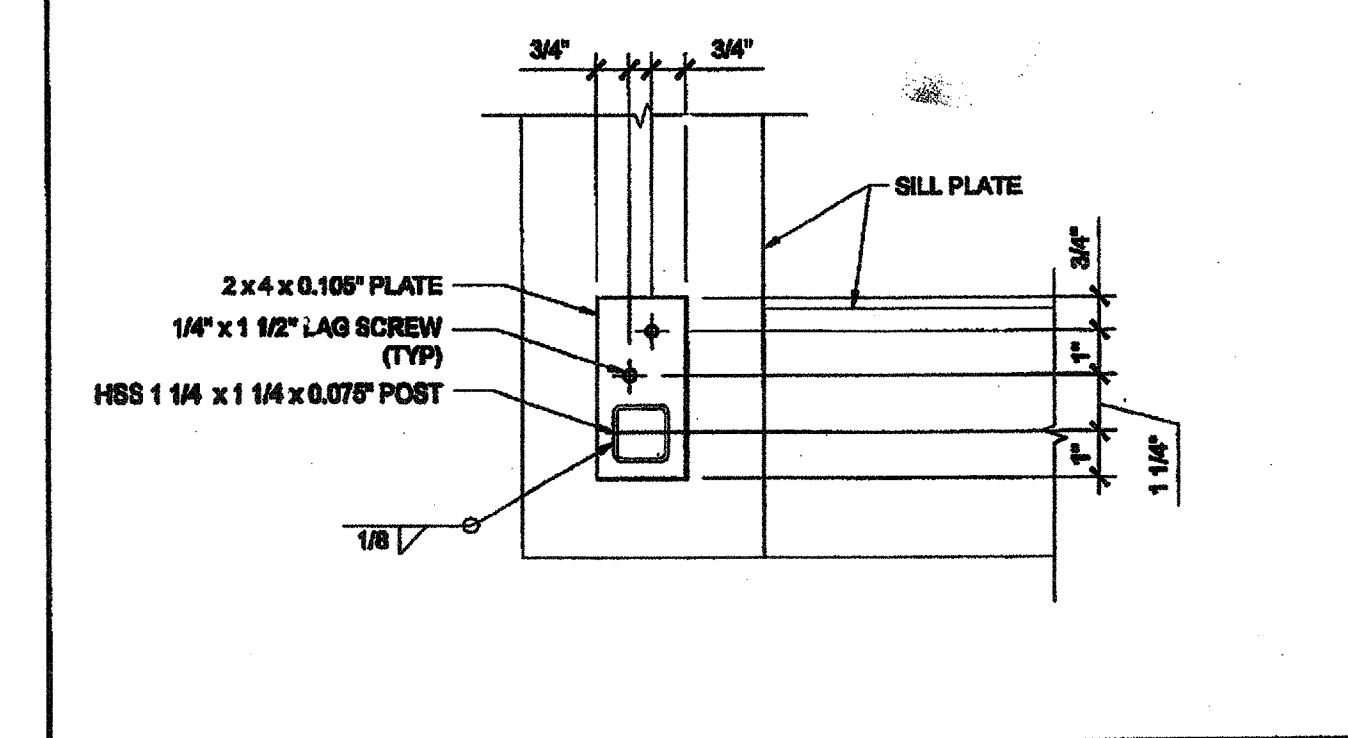

ADJUSTABLE LEG BASE PLATE SCALE: 3\"/>

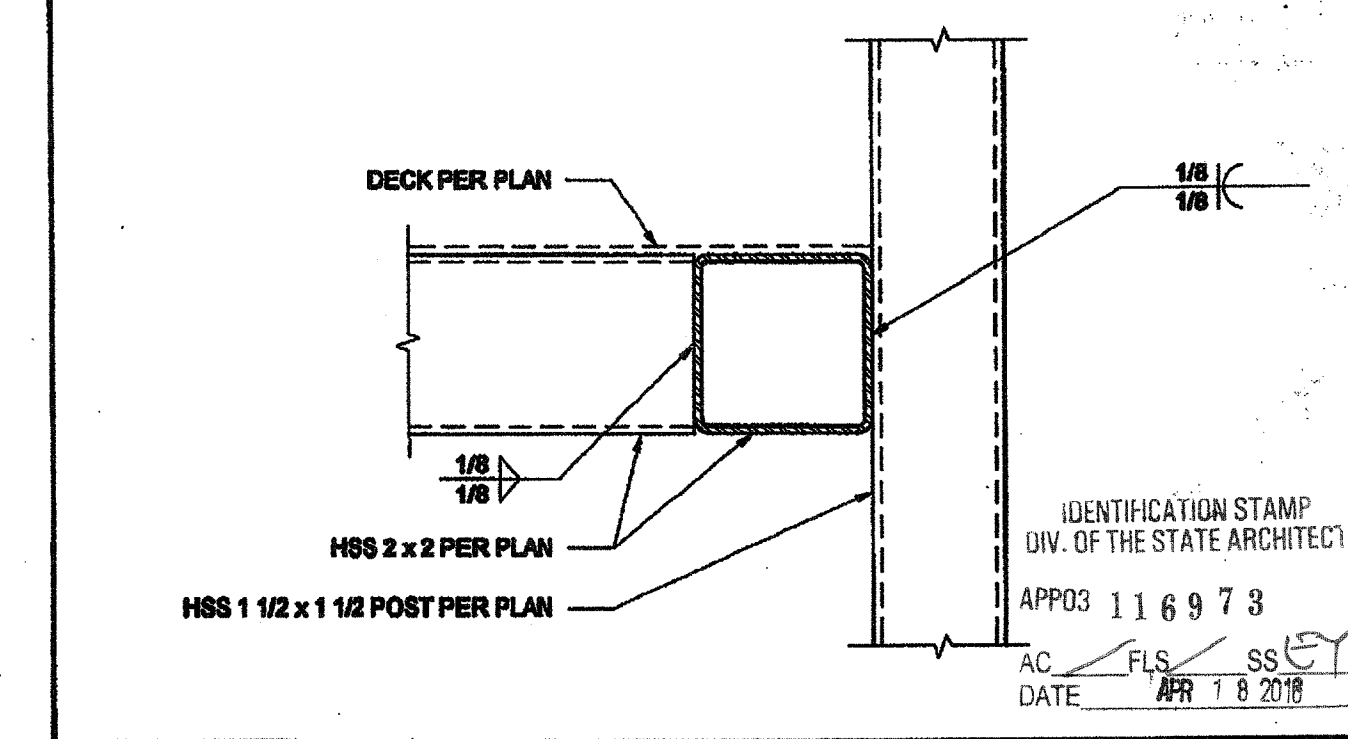

GUARDRAIL POST ATTACHMENT SCALE: 6\"/>

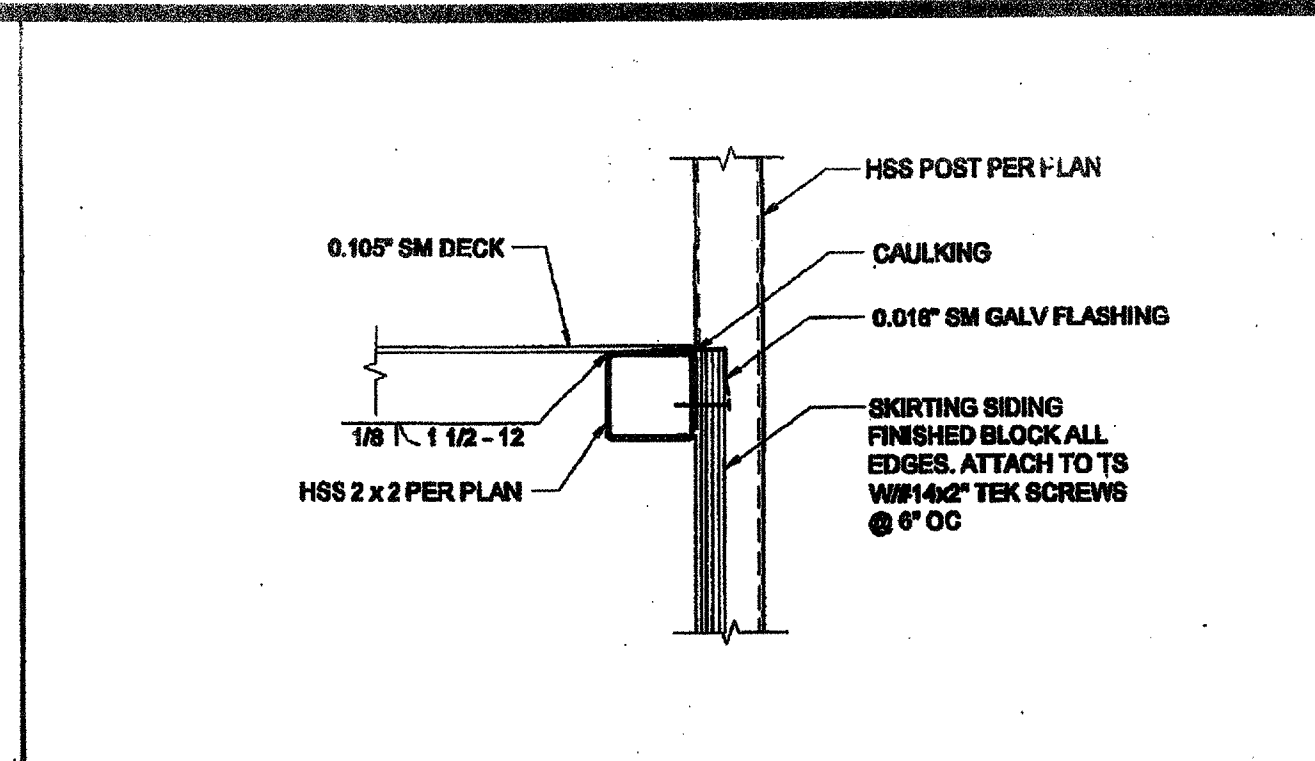

SKIRT FLASHING SCALE: 3\"/>

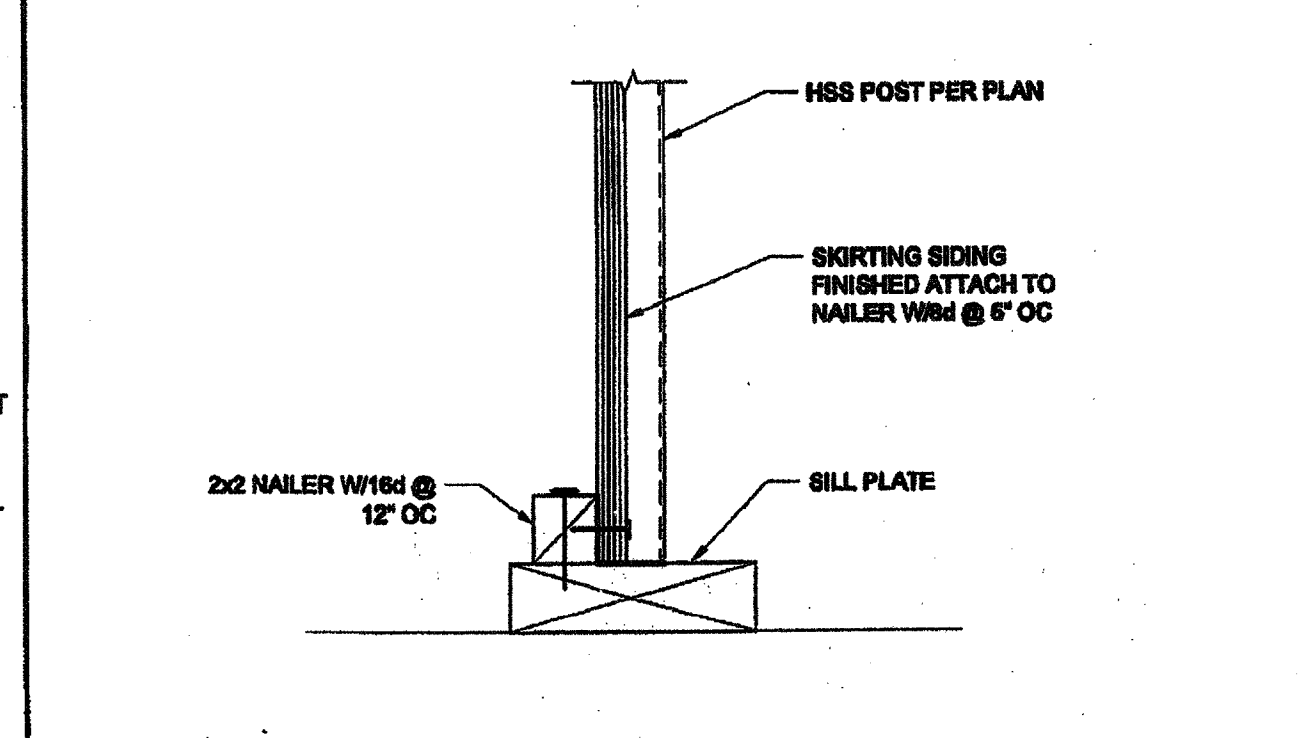

SKIRT FLASHING AT SILL PLATE SCALE: 3\"/>

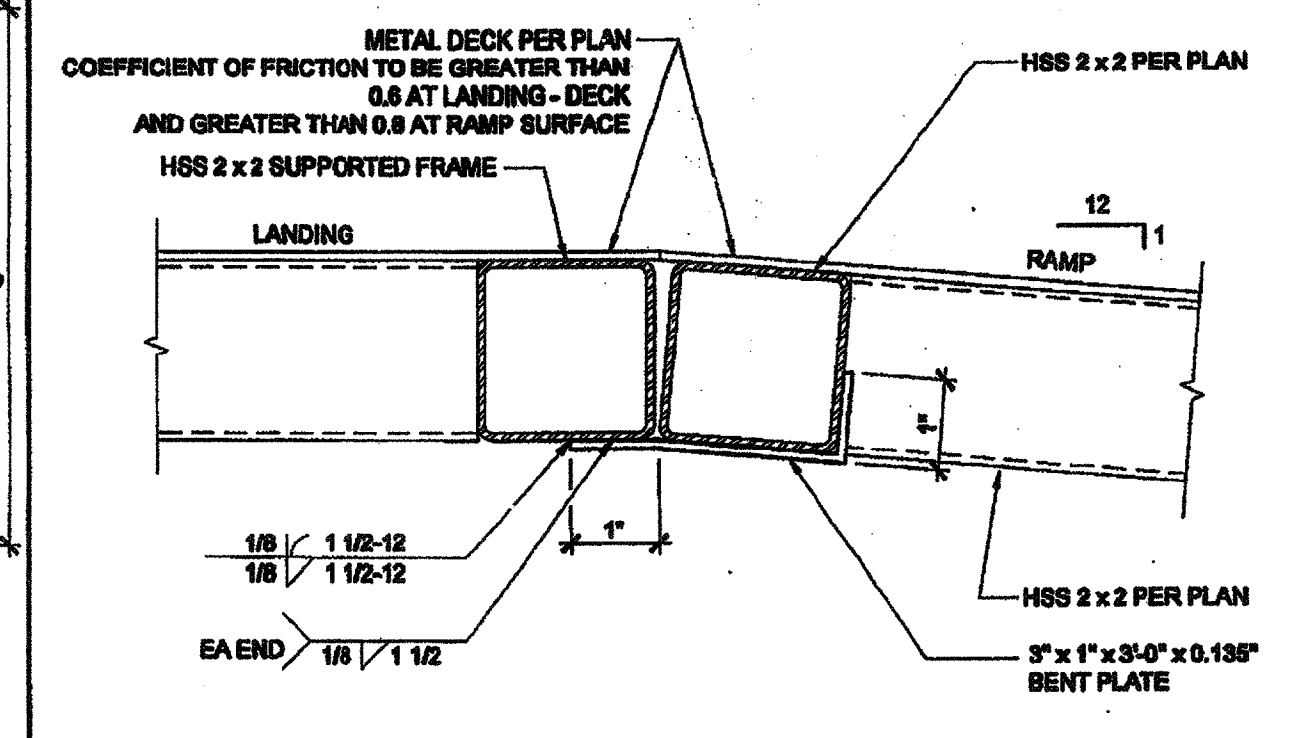

RAMP AT LANDING SCALE: 6\"/>

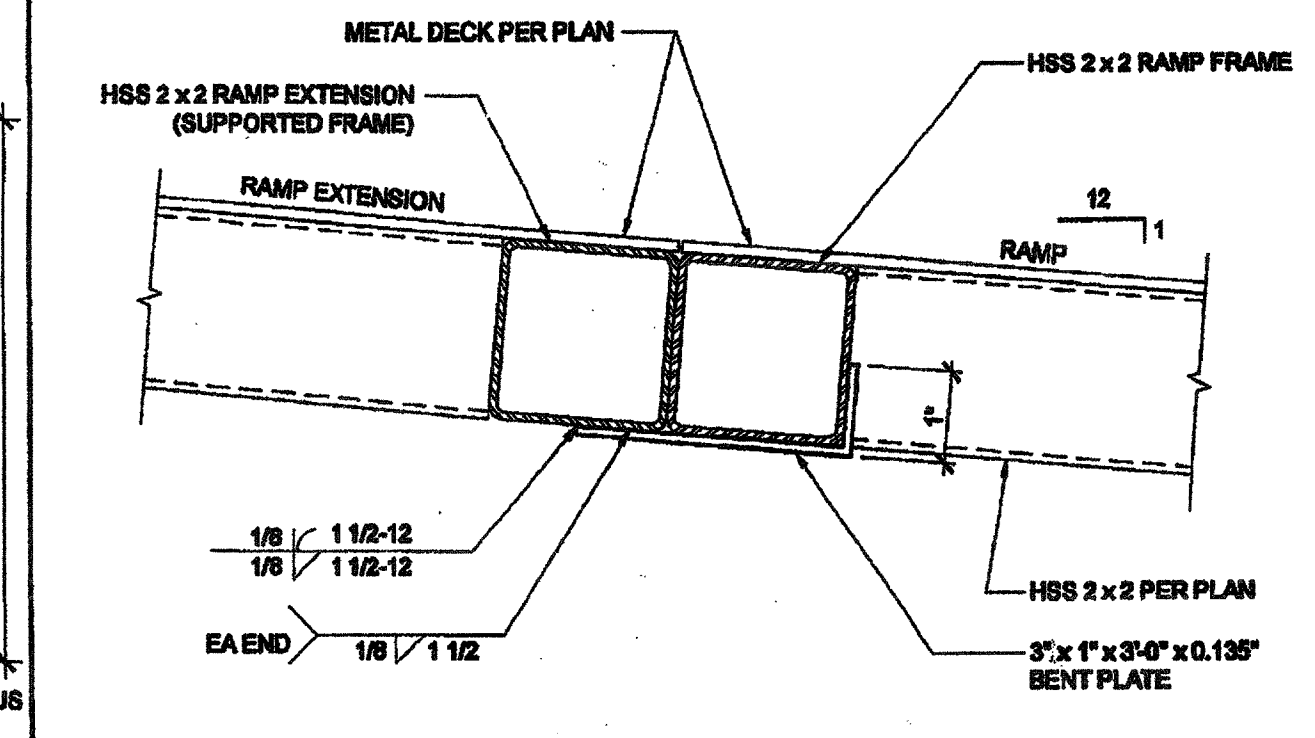

RAMP EXTENSION SCALE: 6\"/>

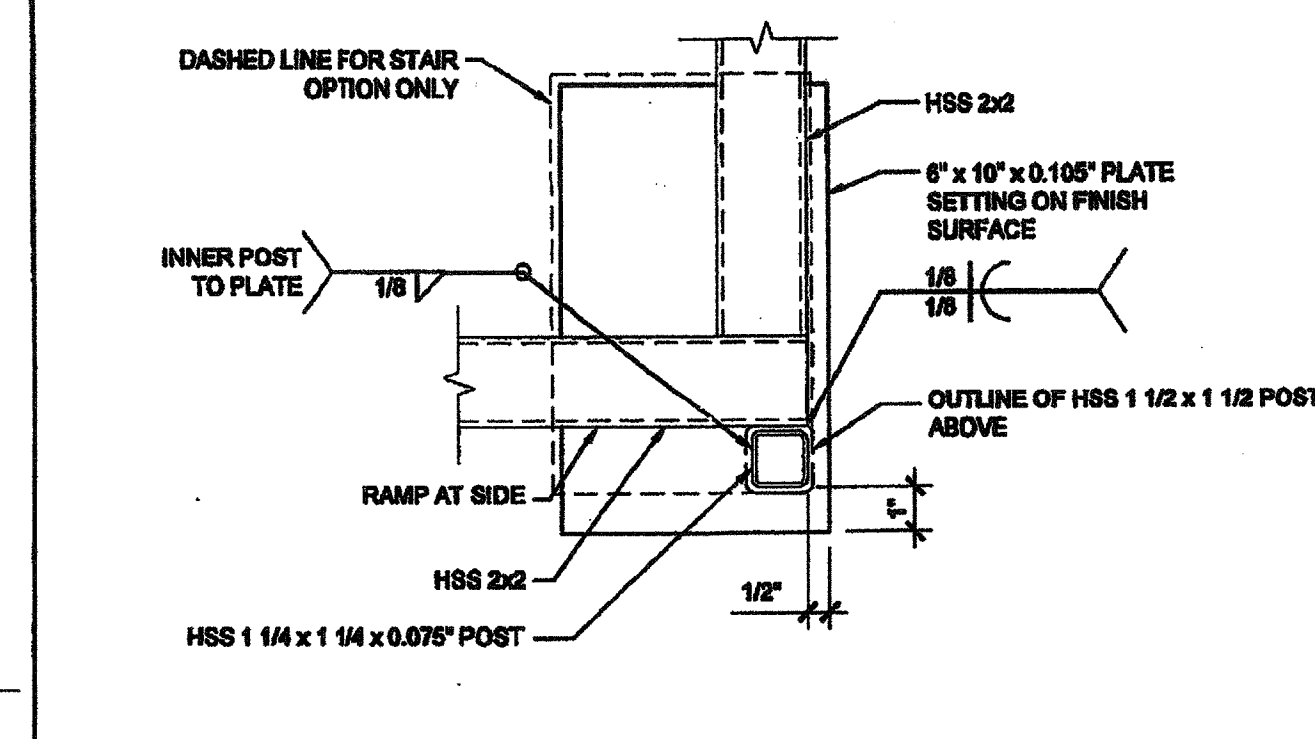

BASE PLATE AT RAMP TOE SCALE: 3\"/>

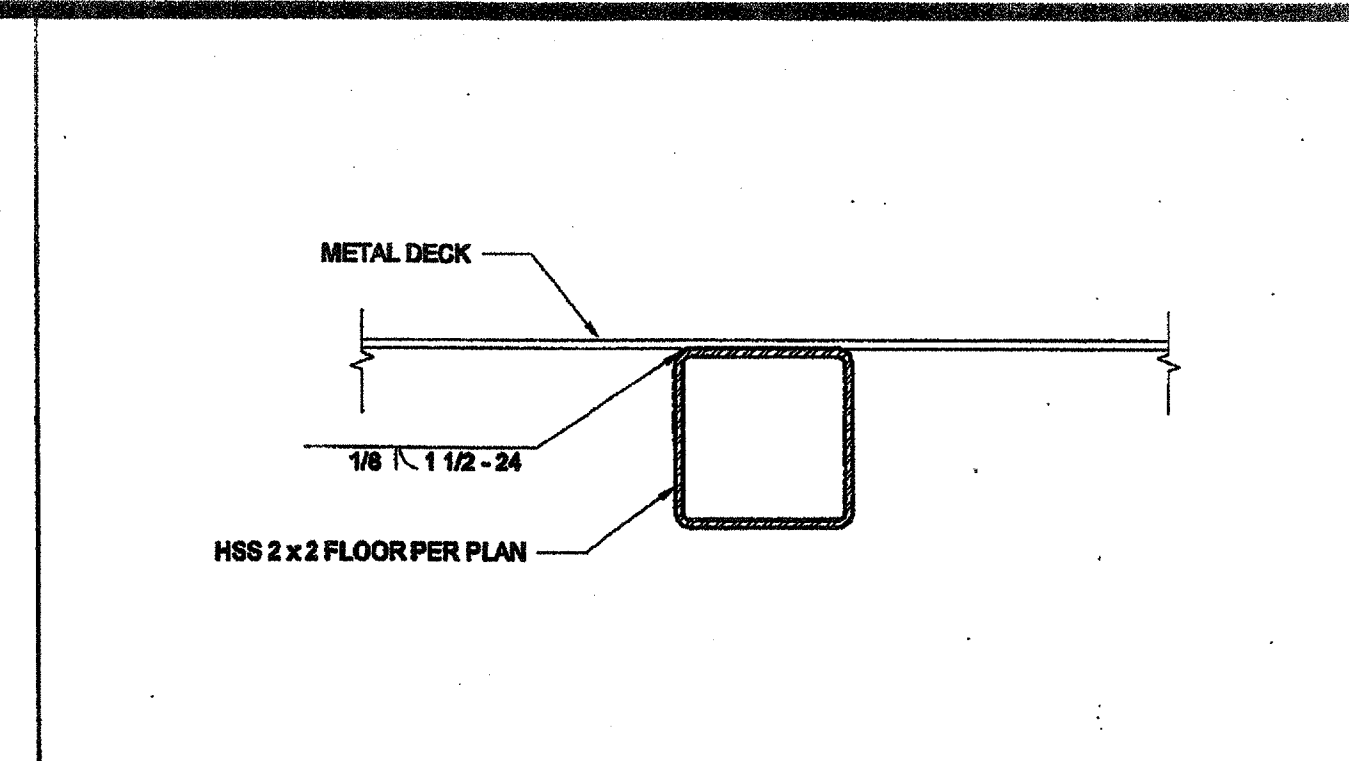

DECK TO FRAME SCALE: 6\"/>

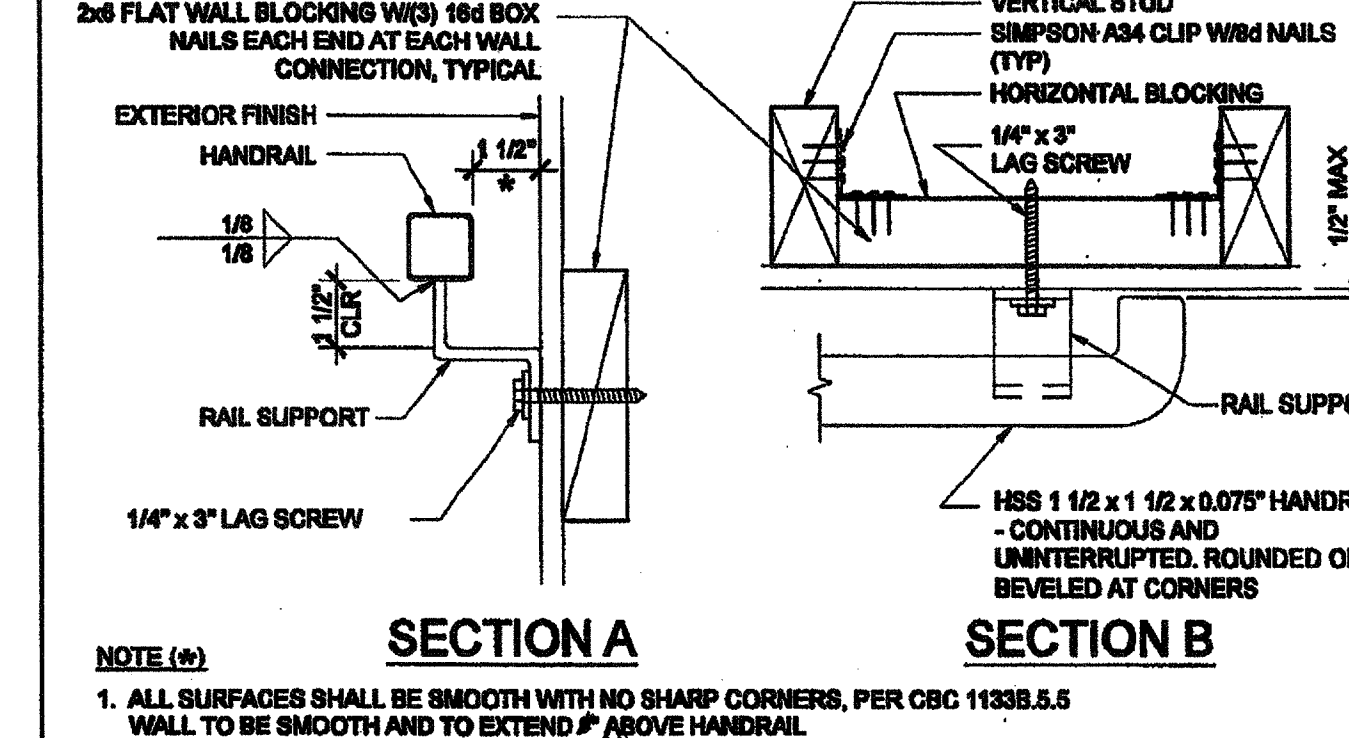

HANDRAIL CONNECTION AT WOOD BLOCKING SCALE: 3\"/>

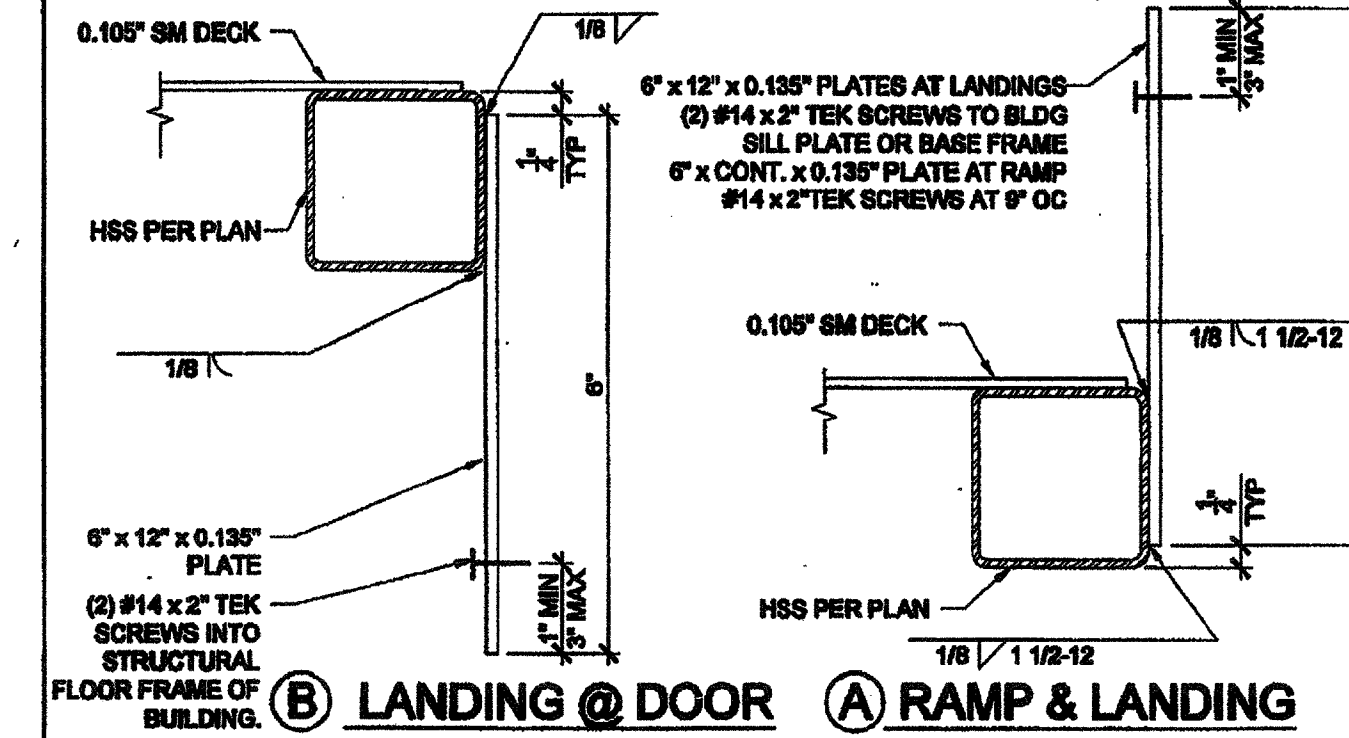

SECTION AT PLATE SCALE: 6\"/>

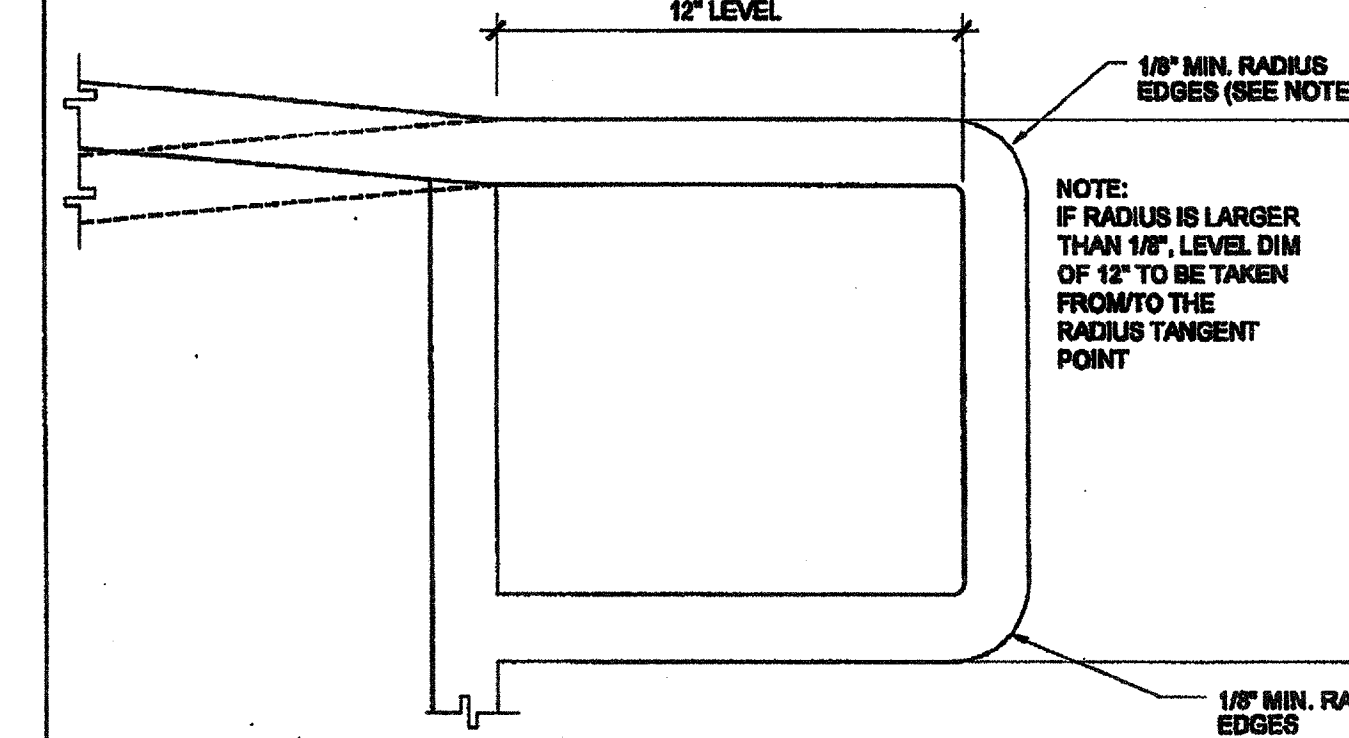

EXTEND HANDRAIL @ TOP OR BOTT. ENDS SCALE: 3\"/>

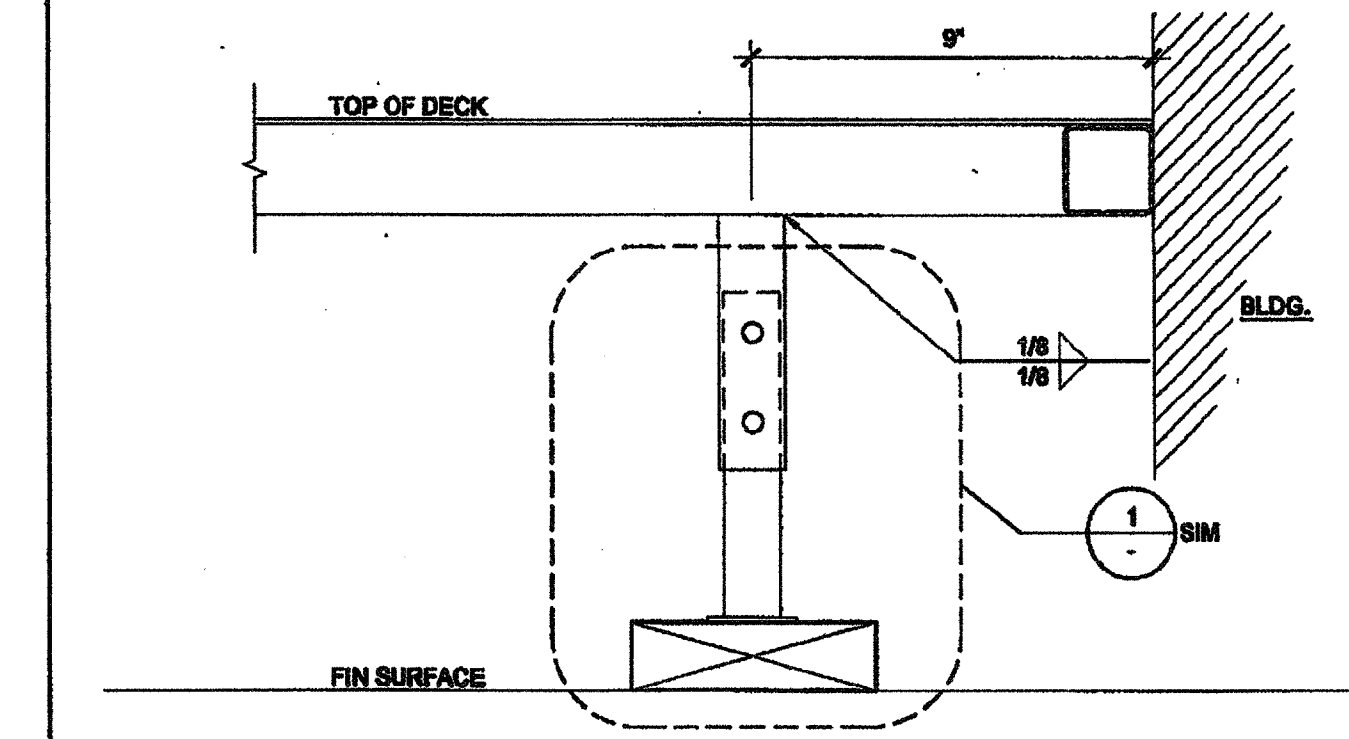

INTERIOR LANDING LEG SECTION SCALE: 3\"/>

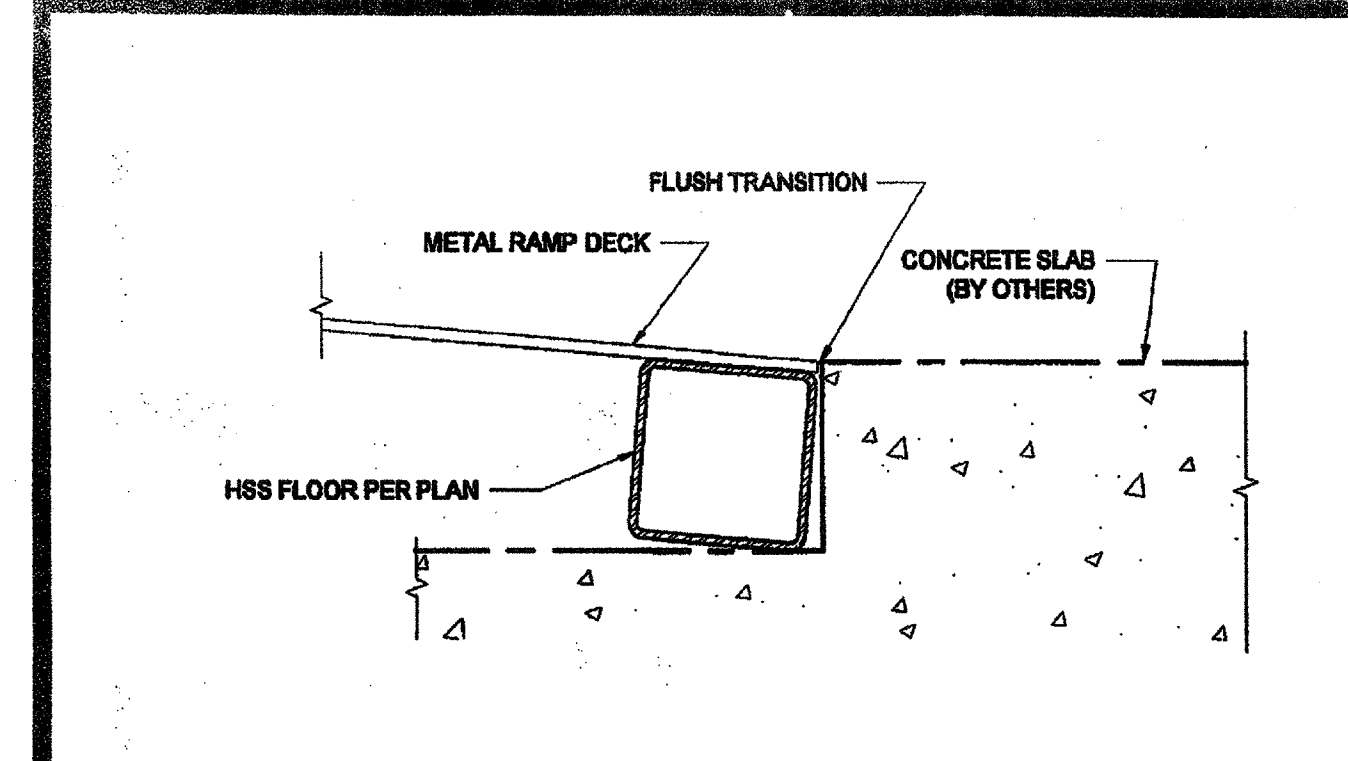

FLUSH TRANSITION AT BOTTOM OF RAMP SCALE: 6\"/>

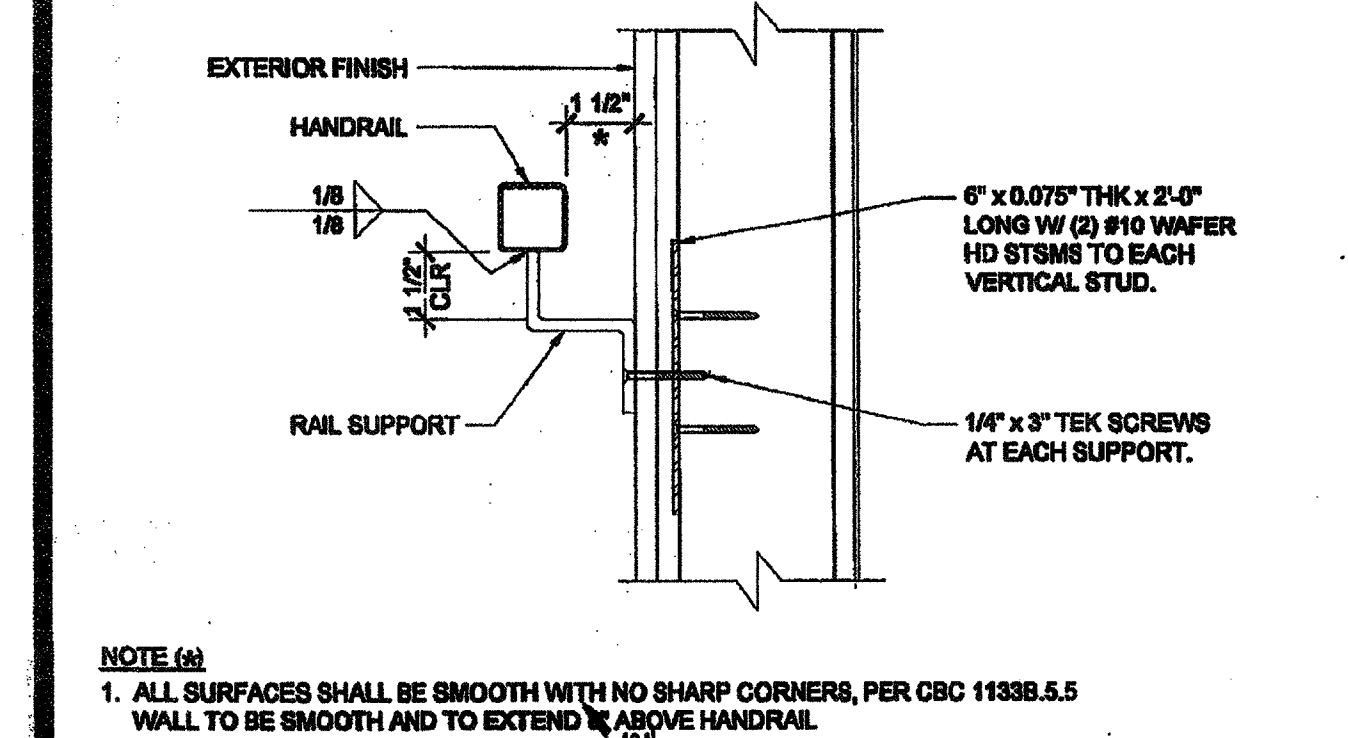

HANDRAIL CONNECTION AT SHEETMETAL BLKG SCALE: 3\"/>



HANDRAIL CONNECTION AT WOOD BLOCKING SCALE: 3\"/>

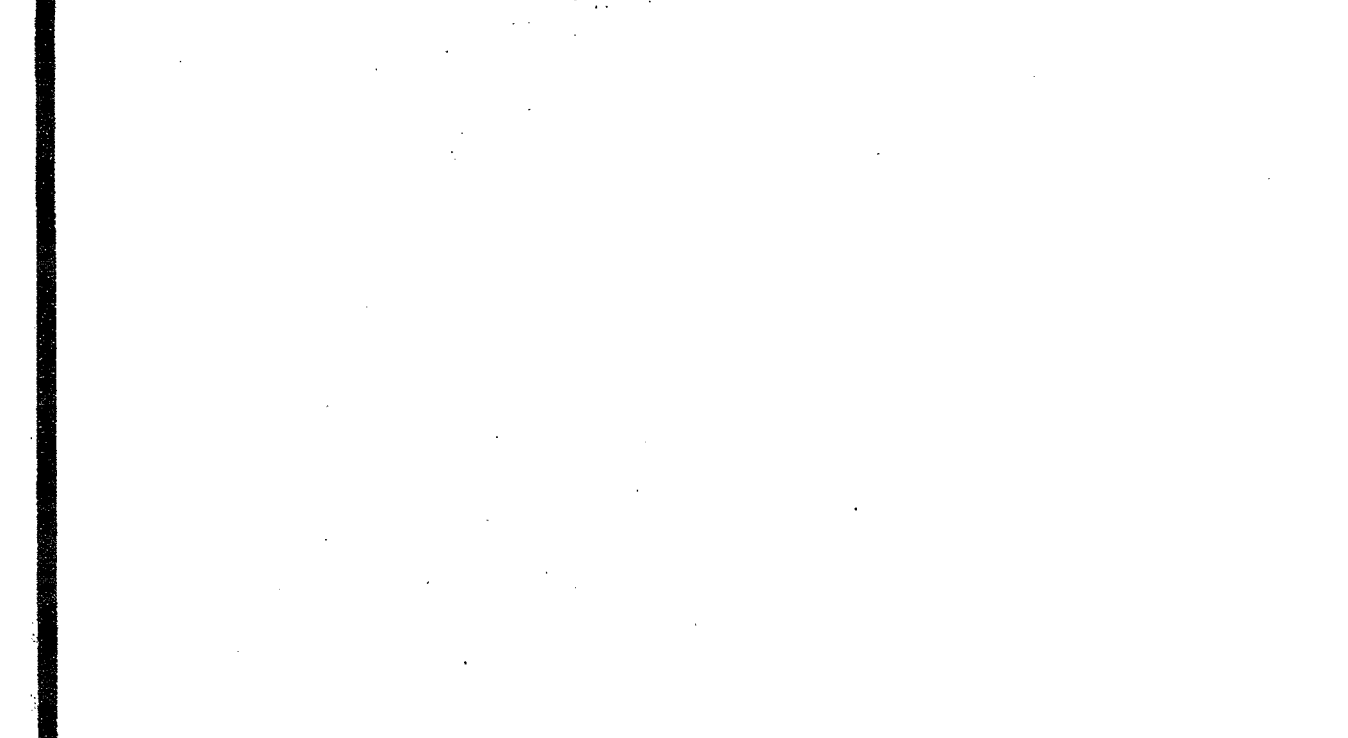

RAMP AT LANDING SCALE: 6\"/>



BASE PLATE AT RAMP TOE SCALE: 3\"/>

INTERIOR LANDING LEG SECTION SCALE: 3\"/>

FLUSH TRANSITION AT BOTTOM OF RAMP SCALE: 6\"/>