

THESE DRAWINGS AND ALL MATERIAL CONTAINED HEREIN ARE THE PROPERTY OF SILVERCREEK INDUSTRIES, INC. (SCI INC) AND SHALL NOT BE REPRODUCED, COPIED OR OTHERWISE DISPOSED OF DIRECTLY OR INDIRECTLY AND SHALL NOT BE USED IN WHOLE OR IN PART TO ASSIST IN THE MAKING OF OR FOR THE PURPOSE OF FURNISHING ANY INFORMATION FOR THE MAKING OF DRAWINGS, PRINTS, APPARATUS OR PARTS THEREOF WITHOUT THE FULL KNOWLEDGE AND WRITTEN CONSENT OF SCI INC. ALL PATENTABLE MATERIAL CONTAINED HEREIN AND ORIGINATING WITH SCI INC SHALL BE THE PROPERTY OF SCI INC.

SILVER CREEK INDUSTRIES, INC.



195 EAST MORGAN FERRIS, CALIFORNIA 92571
PHONE: 951-943-5393 FAX: 951-943-2211

PROJECT NAME:
CLASS LEASING CLASSROOMS BLDG'S

SHEET TITLE:
ARCHITECTURAL DETAILS MISCELLANEOUS/OPTIONS



REVISED
FEB 26 2015
ON THE STATE ARCHITECT ARCHITECT OF RECORD OFFICE OF REGULATION SERVICES
04 11 1892
AG: [Signature] SS: [Signature]
DATE: NOV 20 2011

PROJECT SPECIFIC STATE AGENCY APPROVAL
IDENTIFICATION STAMP
DIV. OF THE STATE ARCHITECT OFFICE OF REGULATION SERVICES
04 11 1892
AG: [Signature] SS: [Signature]
DATE: AUG 28 2011

ORIGINAL PC STATE AGENCY APPROVAL
IDENTIFICATION STAMP
DIV. OF THE STATE ARCHITECT OFFICE OF REGULATION SERVICES
PC 04-112072
AG: [Signature] SS: [Signature]
DATE: DEC 28 2011

REVISIONS

SILVER CREEK INDUSTRIES
24' x 40' PC
PROJECT NO:
DRAWN BY: AS NOTED
SCALE: AS NOTED
DATE: 12-23-11
P.C. SHEET NUMBER

A-5.80 STKP 126

IDENTIFICATION STAMP
DIV. OF THE STATE ARCHITECT
APPROD 116973
AG: FLS SS: [Signature]
DATE: 1/18/2012

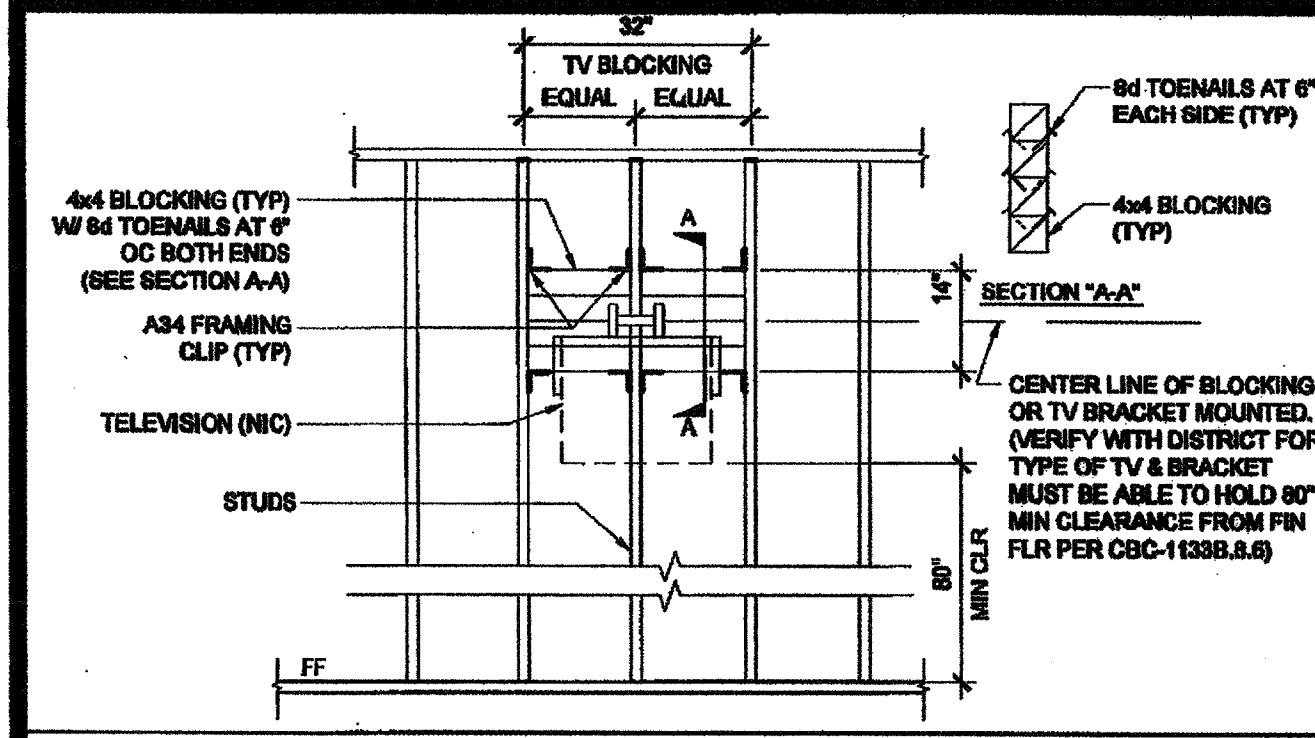

T.V. BLOCKING ATTACHMENT AT WOOD STUD SCALE: 1/2" = 1'-0" 16

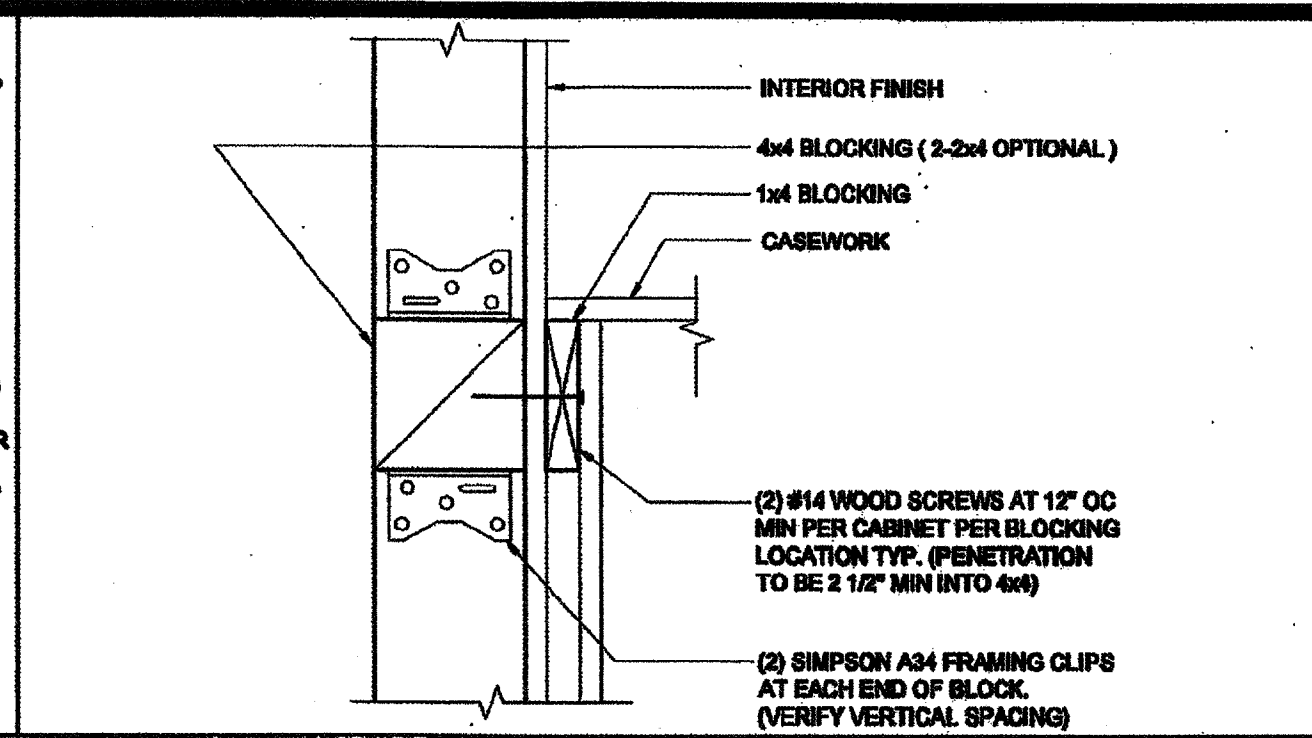

ATTACHMENT TO BLOCKING AT WOOD STUD SCALE: 3/4" = 1'-0" 11

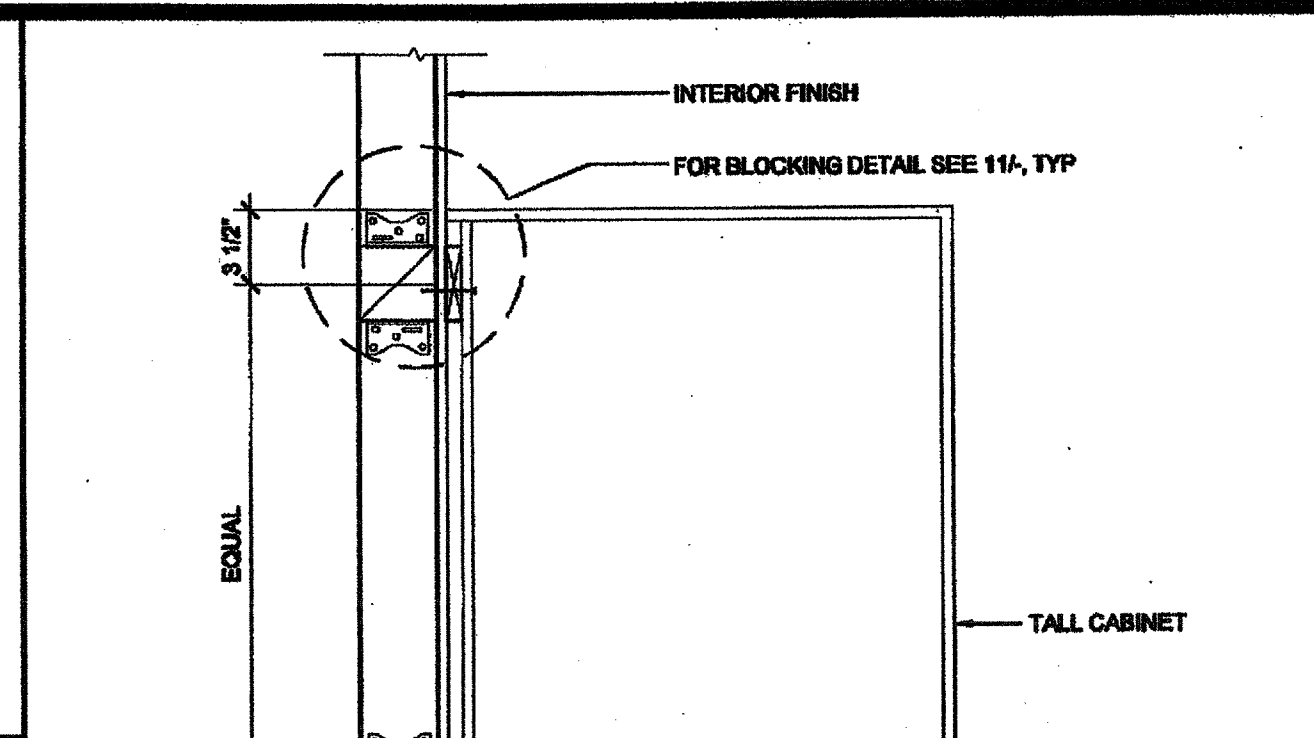

TALL CABINET WALL ANCHORAGE AT WOOD STUD SCALE: 1 1/2" = 1'-0" 7

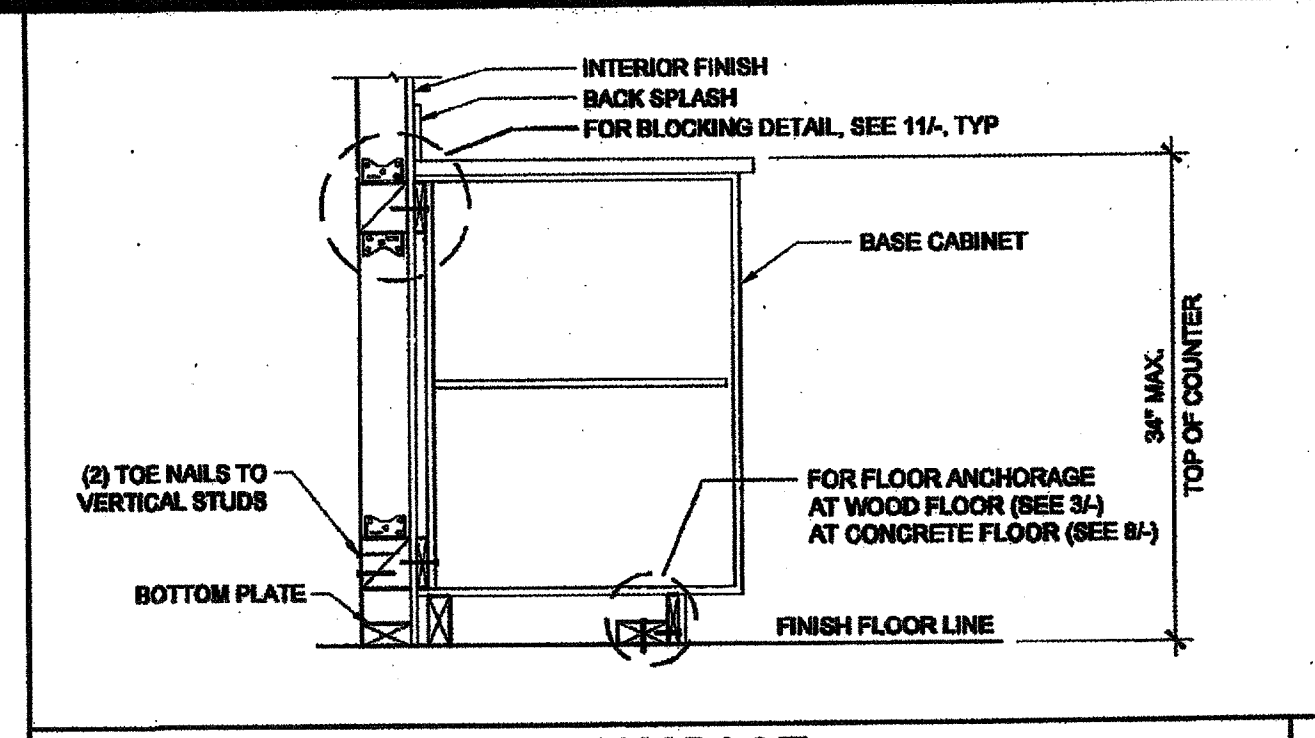

BASE CABINET WALL ANCHORAGE AT WOOD STUD SCALE: 1" = 1'-0" 1

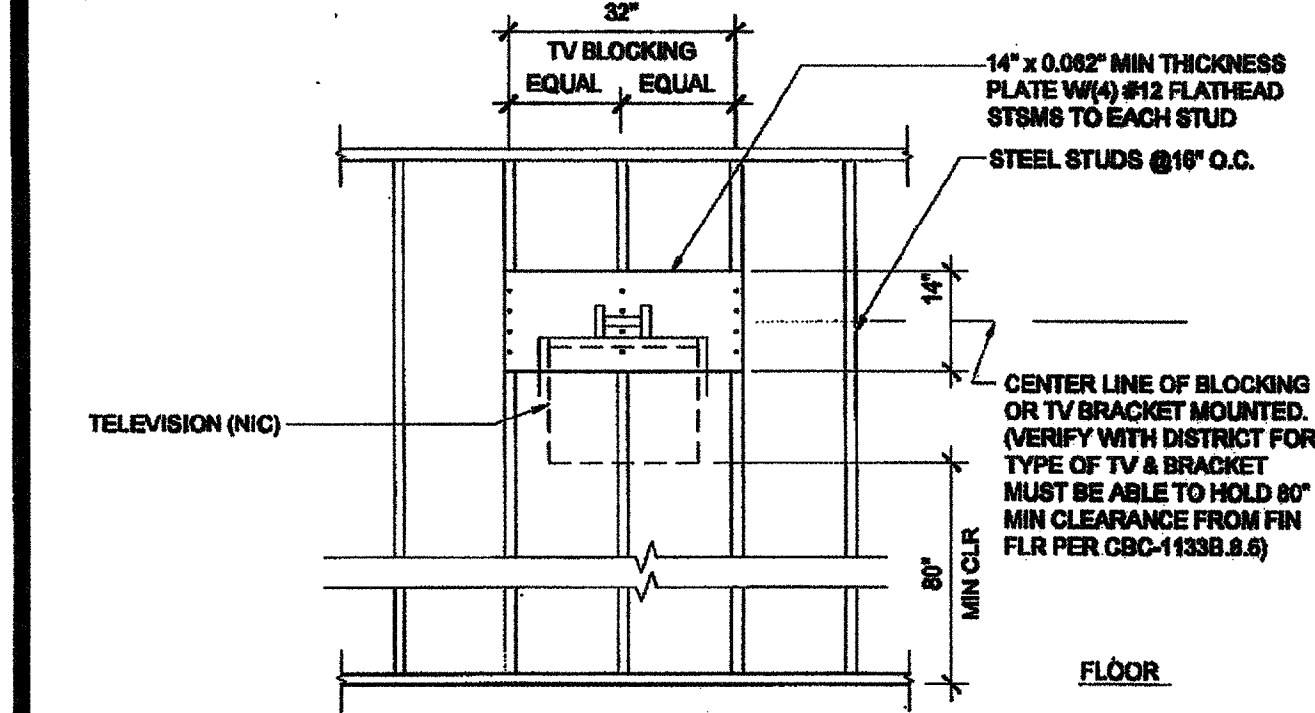

T.V. BLOCKING ATTACHMENT AT STEEL STUD SCALE: 1/2" = 1'-0" 17

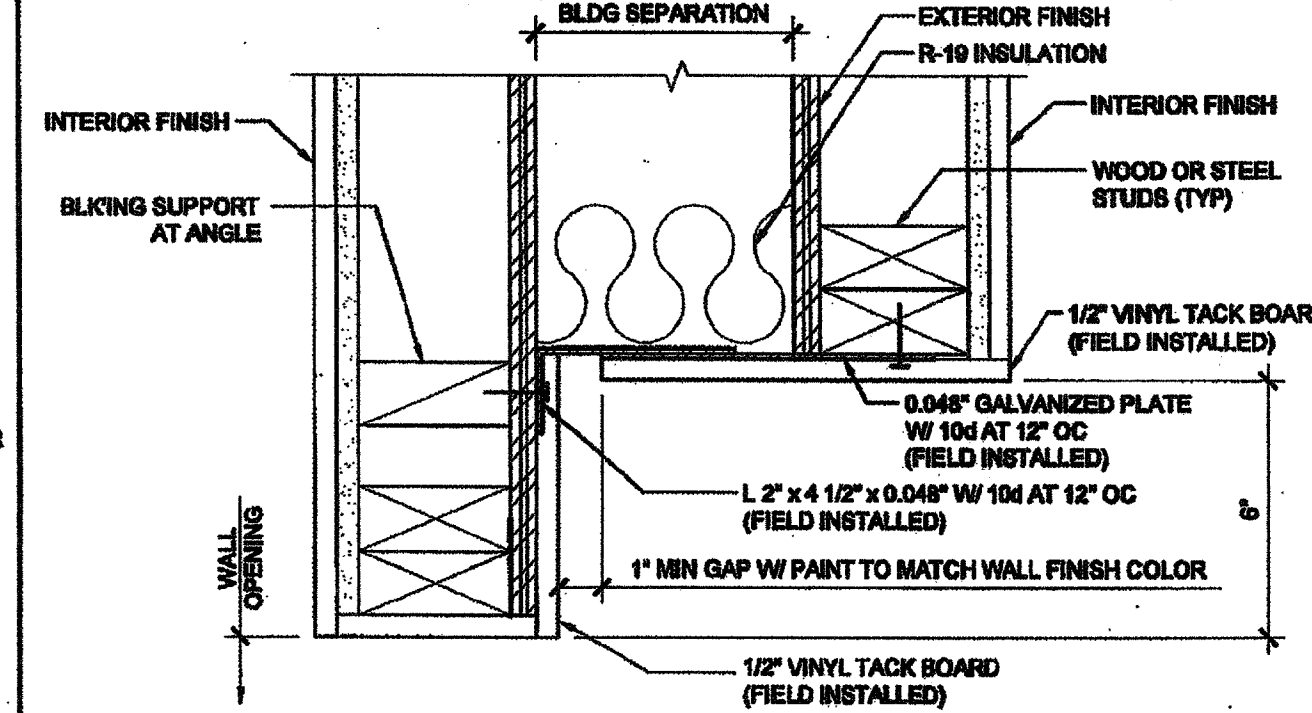

WALL OPENING AT HEADER AND JAMB SCALE: 3/4" = 1'-0" 12

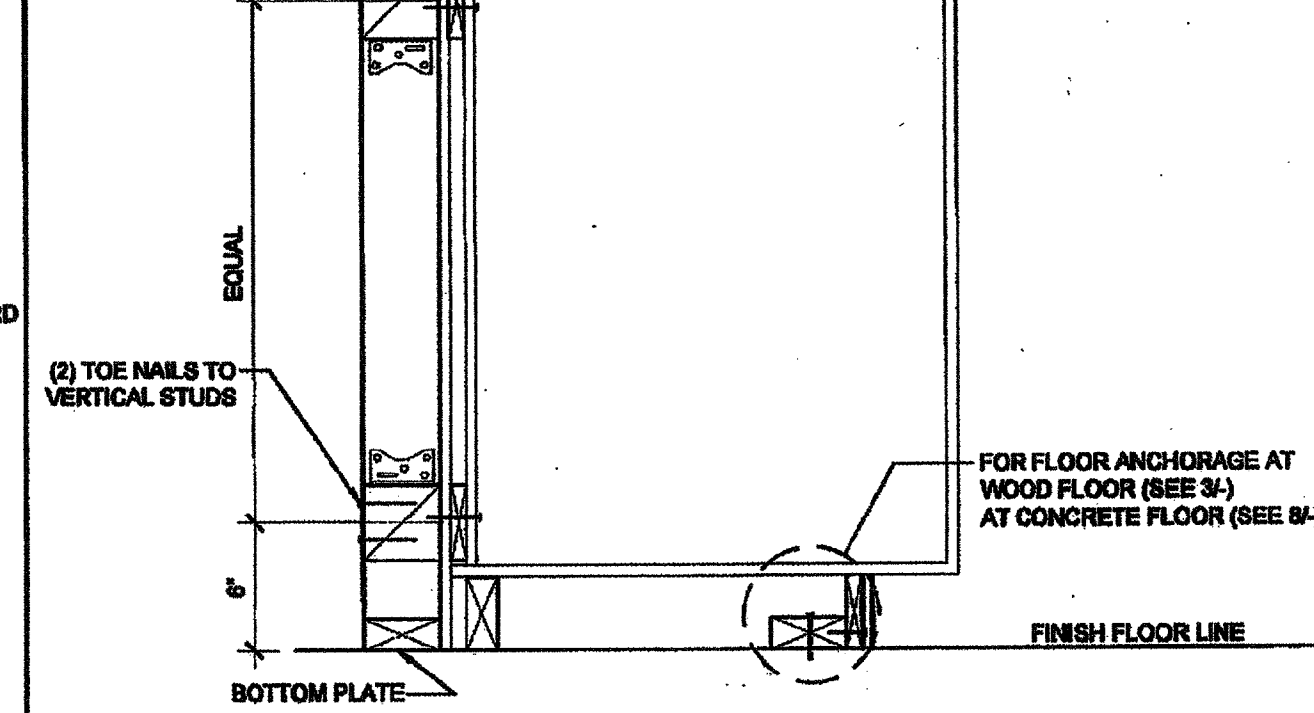

WALL HUNG ANCHORAGE CABINET AT WOOD STUD SCALE: 1 1/2" = 1'-0" 2

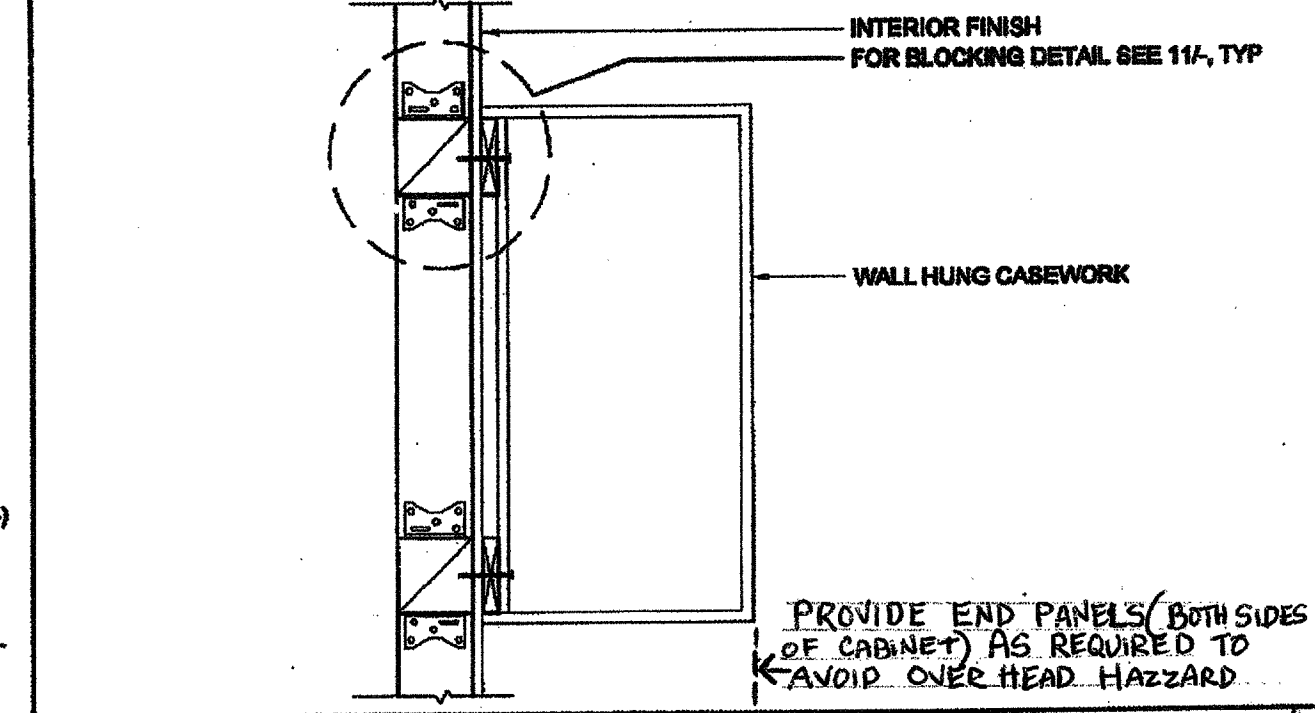

WALL HUNG ANCHORAGE CABINET AT WOOD STUD SCALE: 1 1/2" = 1'-0" 2

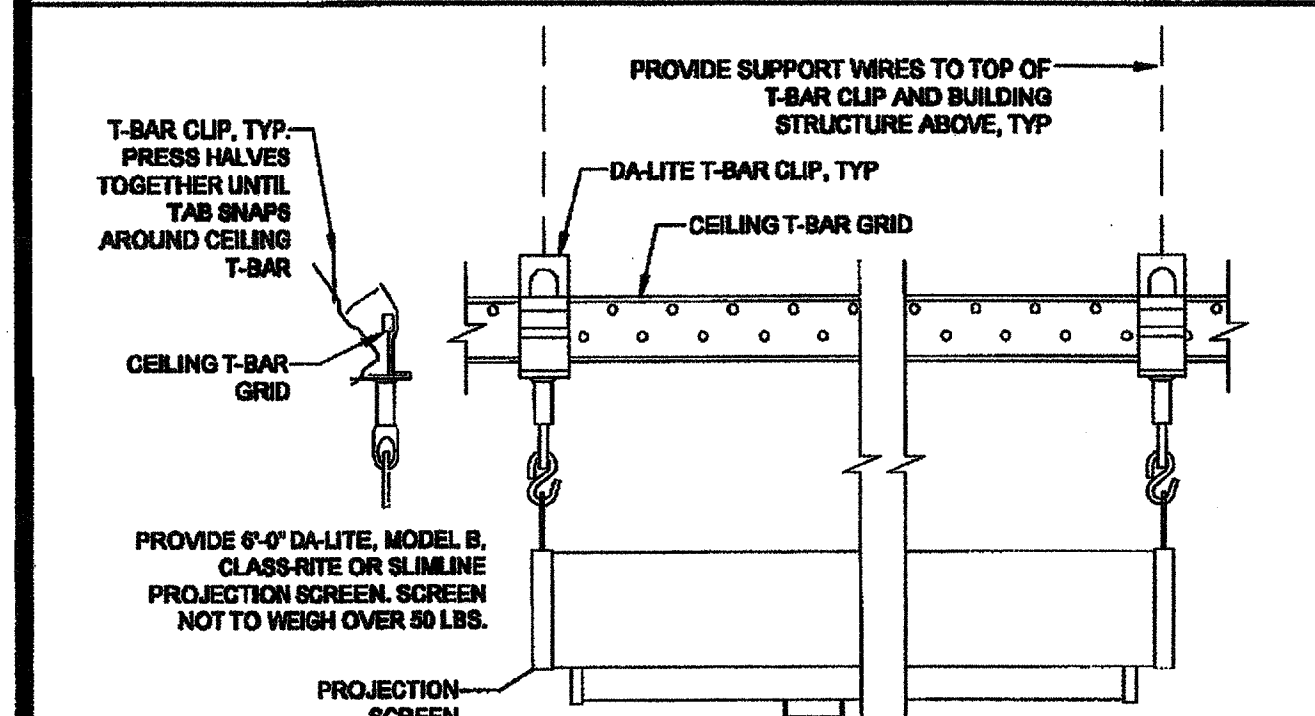

PROJECTION SCREEN MOUNTING SCALE: NTS 18

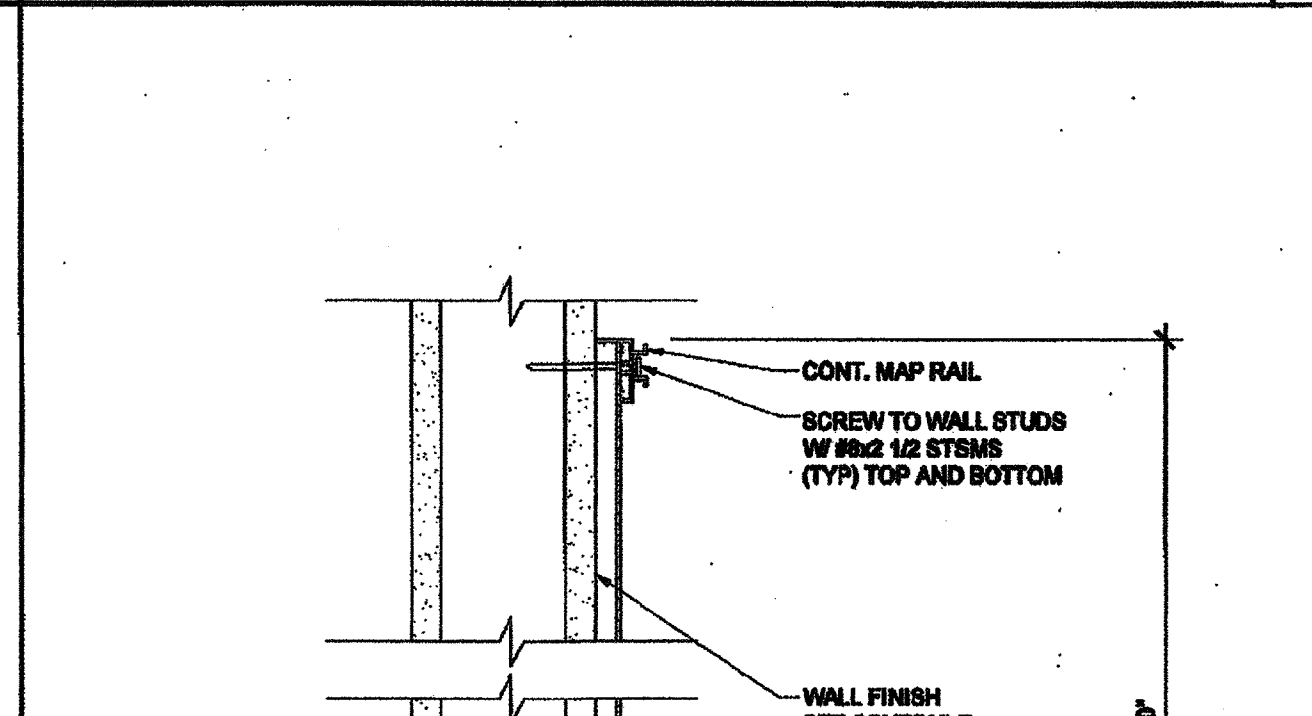

MARKER BOARD ATTACHMENT SCALE: 3/4" = 1'-0" 14

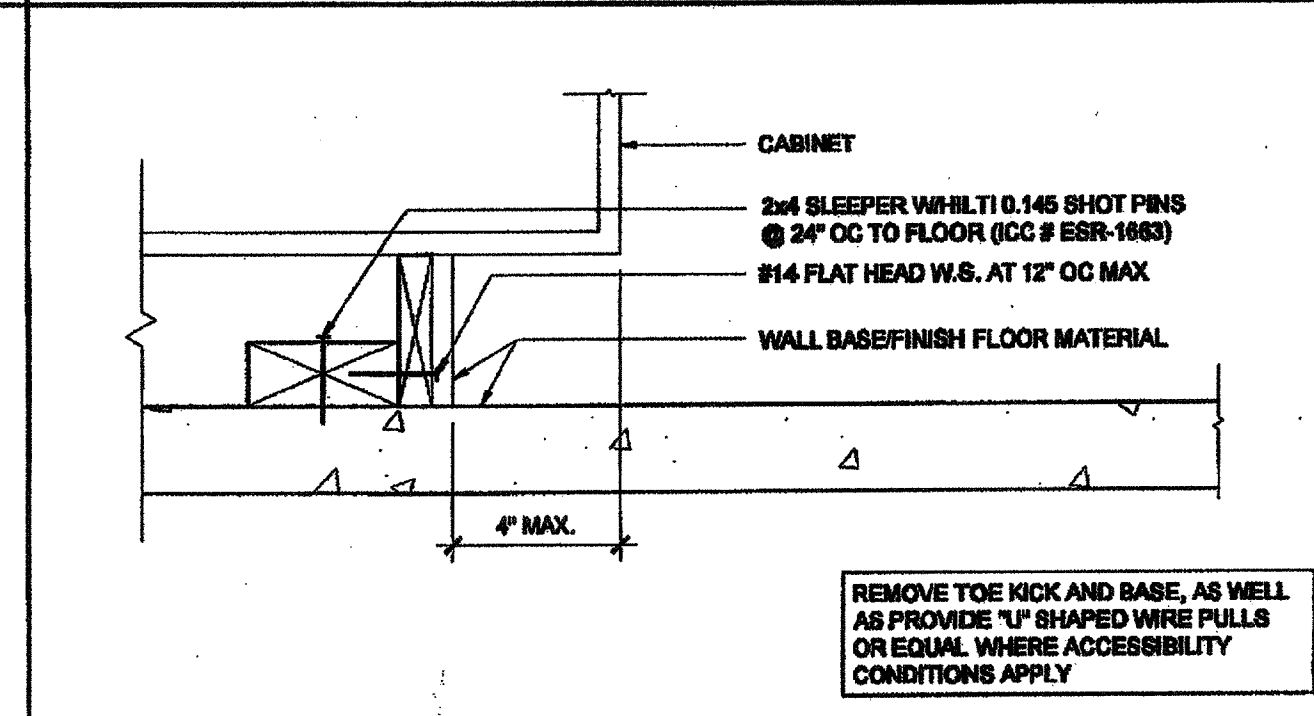

ATTACHMENT TO BLOCKING - CONC. FLOOR SCALE: 3/4" = 1'-0" 8

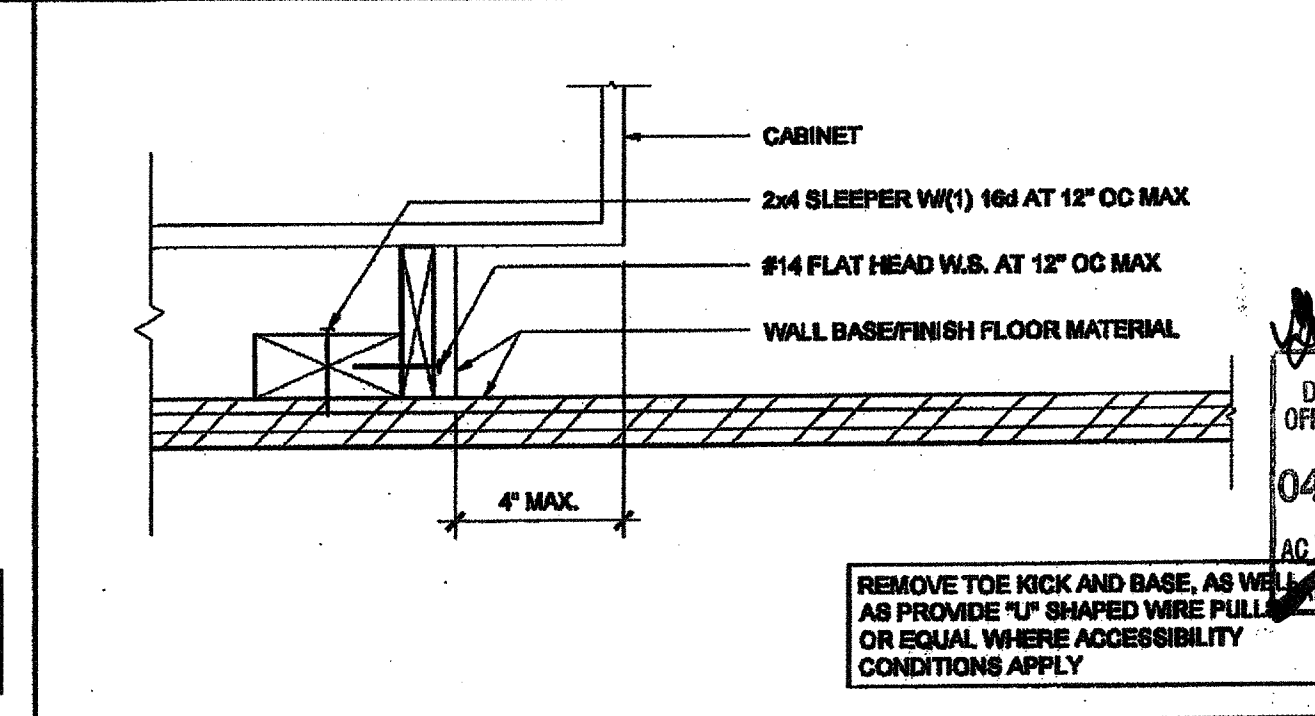

ATTACHMENT TO BLOCKING - WOOD FLOOR SCALE: 3/4" = 1'-0" 3

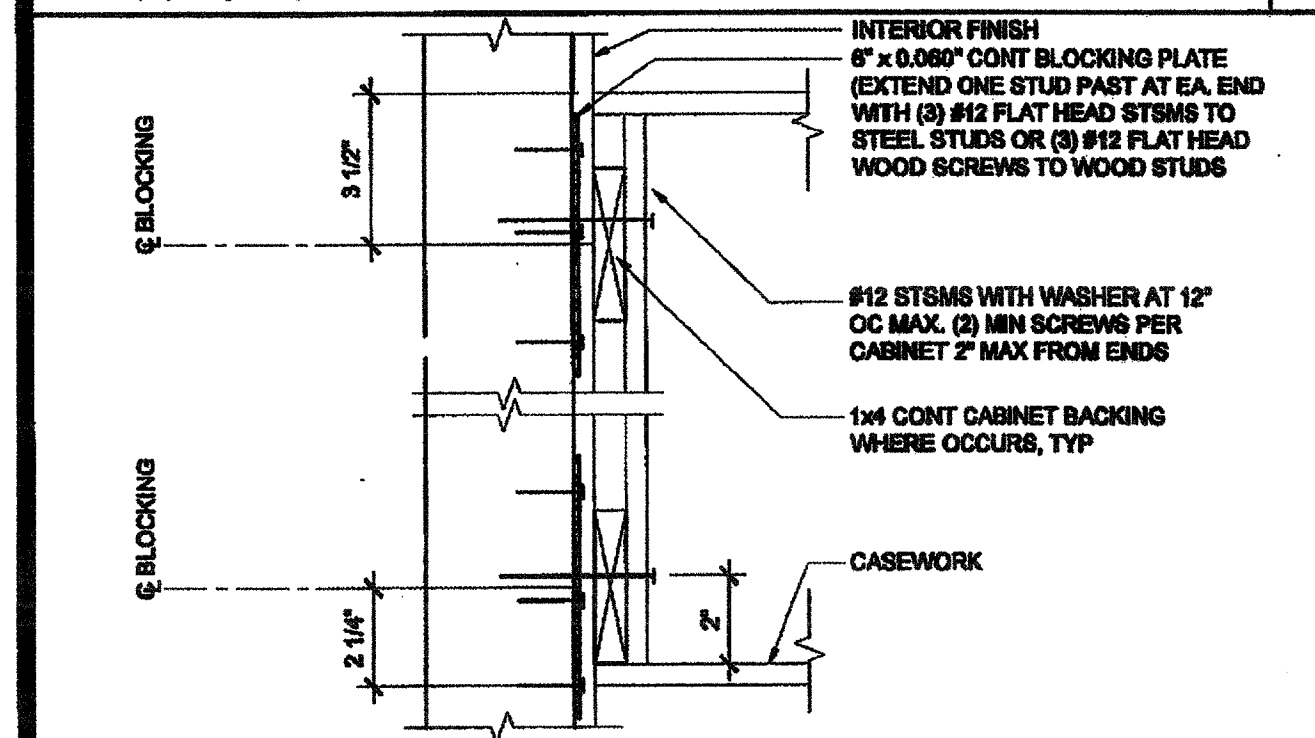

ATTACHMENT TO BLOCKING SCALE: 3/4" = 1'-0" 19

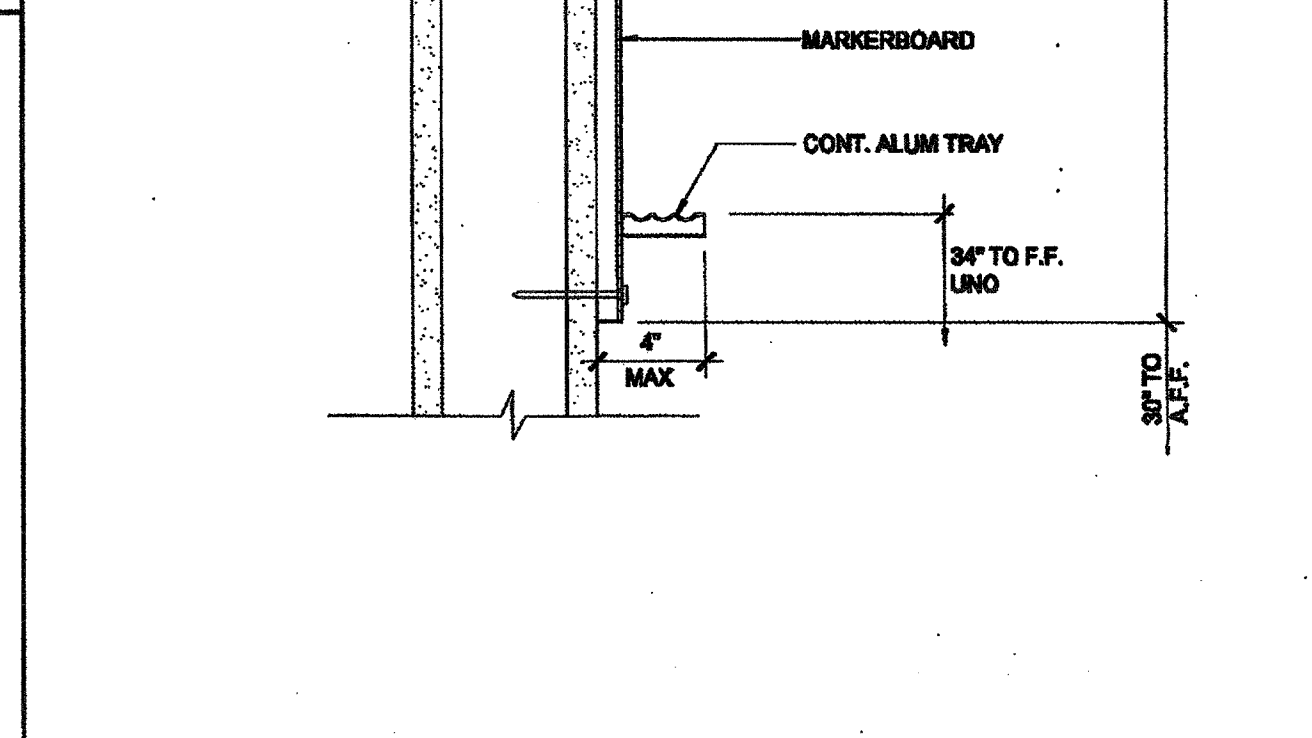

TALL CABINET WALL ANCHORAGE SCALE: 1 1/2" = 1'-0" 10

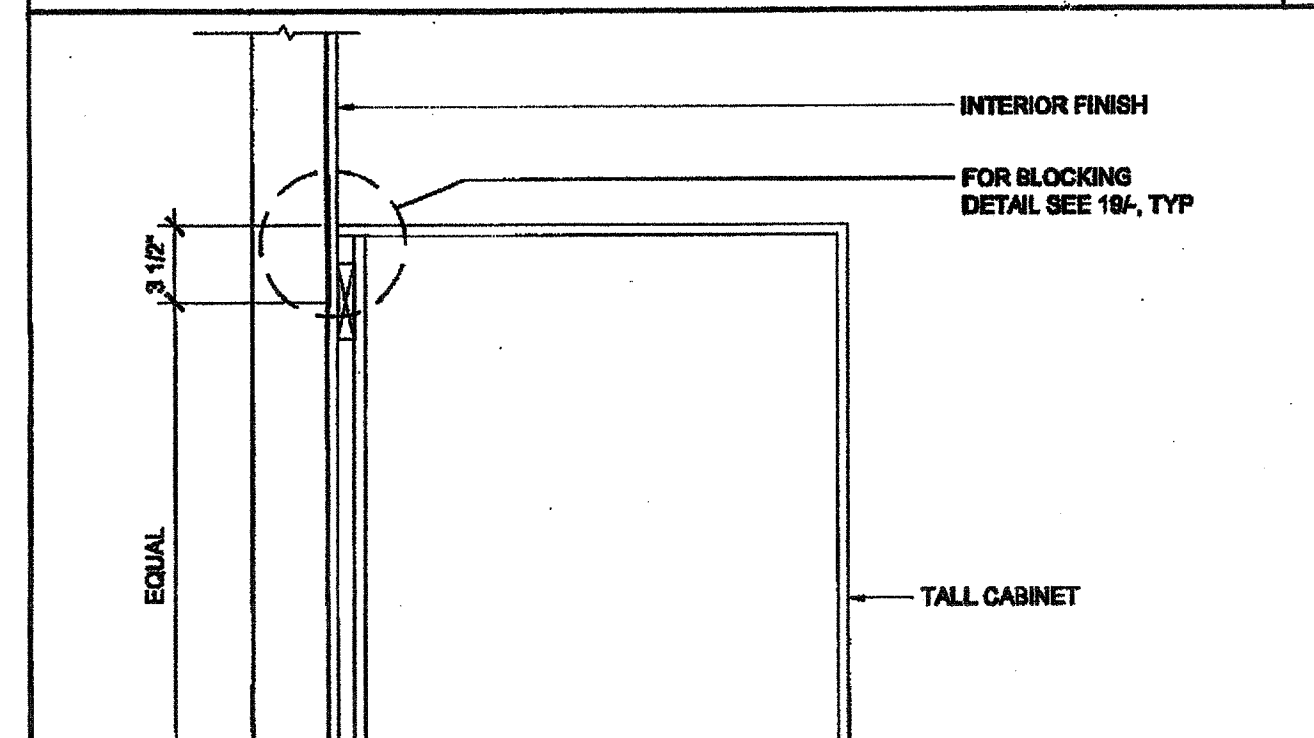

WALL HUNG ANCHORAGE CABINET SCALE: 1 1/2" = 1'-0" 5

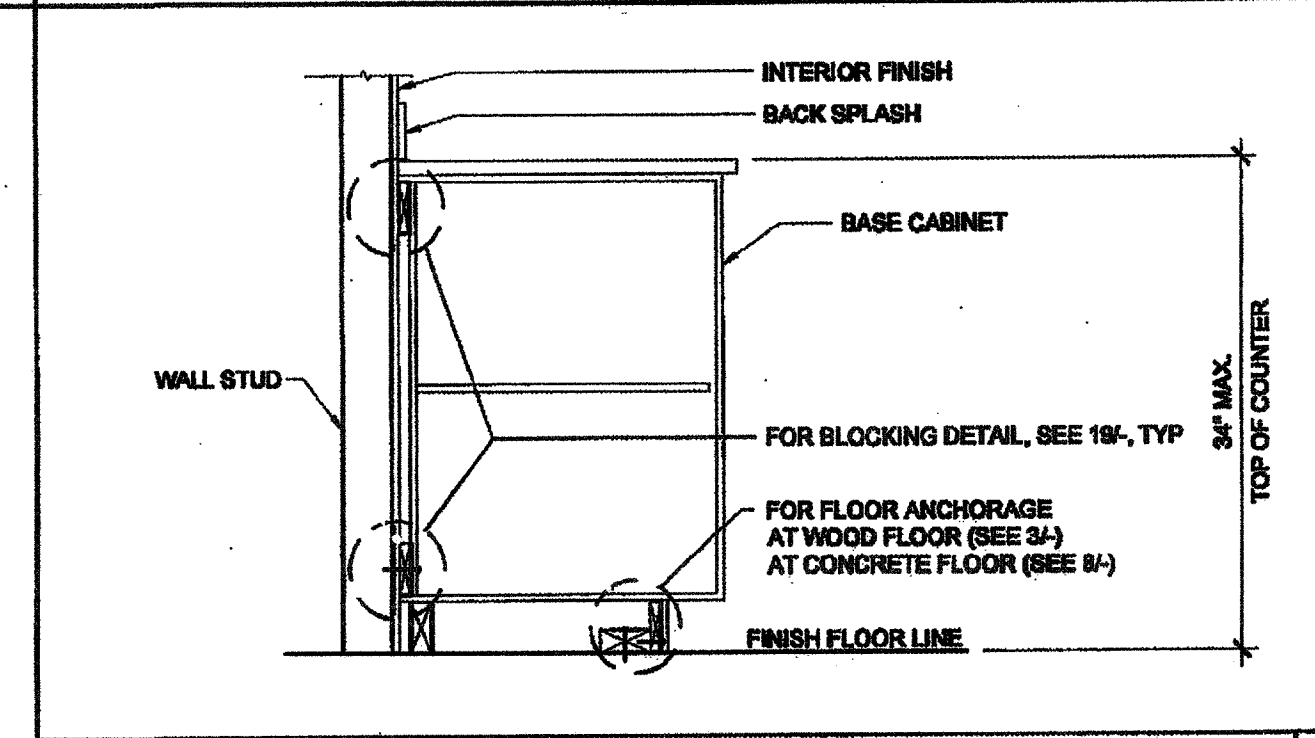

BASE CABINET WALL ANCHORAGE SCALE: 1" = 1'-0" 4

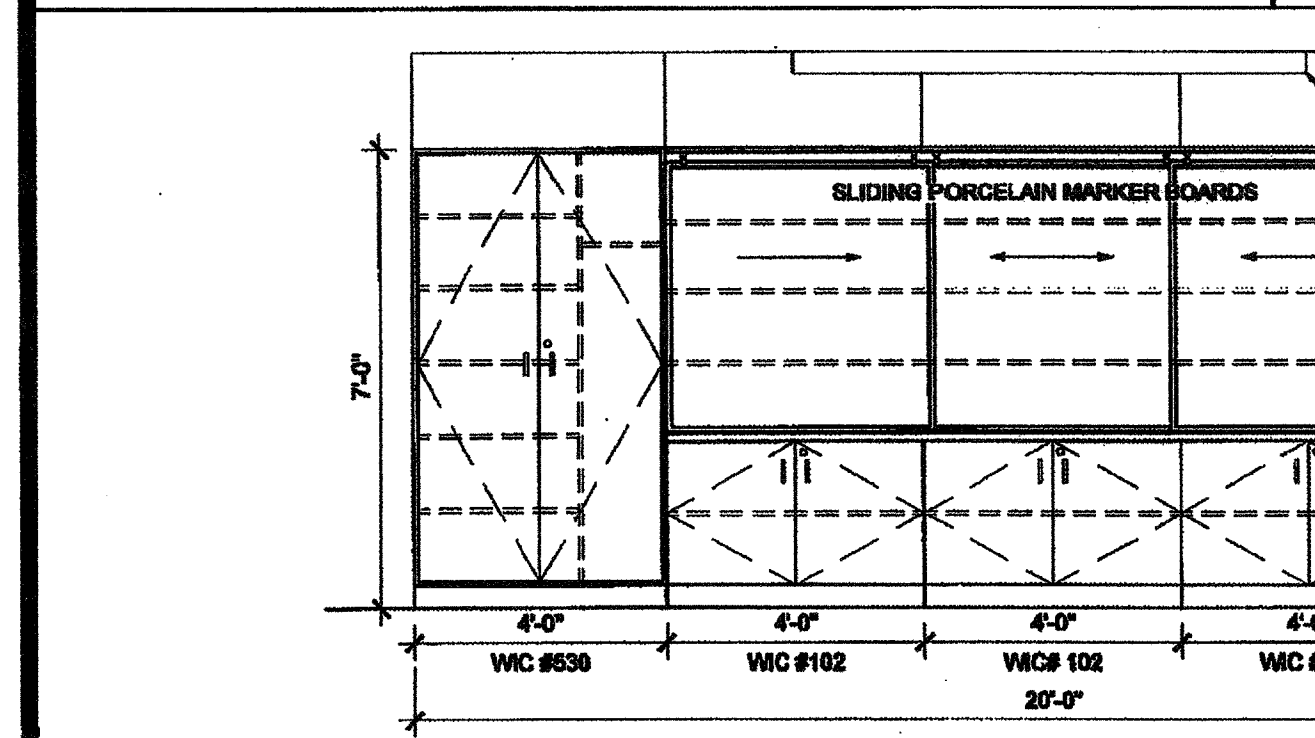

TEACHING WALL - ELEVATION / SECTION - OPTION SCALE: 3/8" = 1'-0" 15

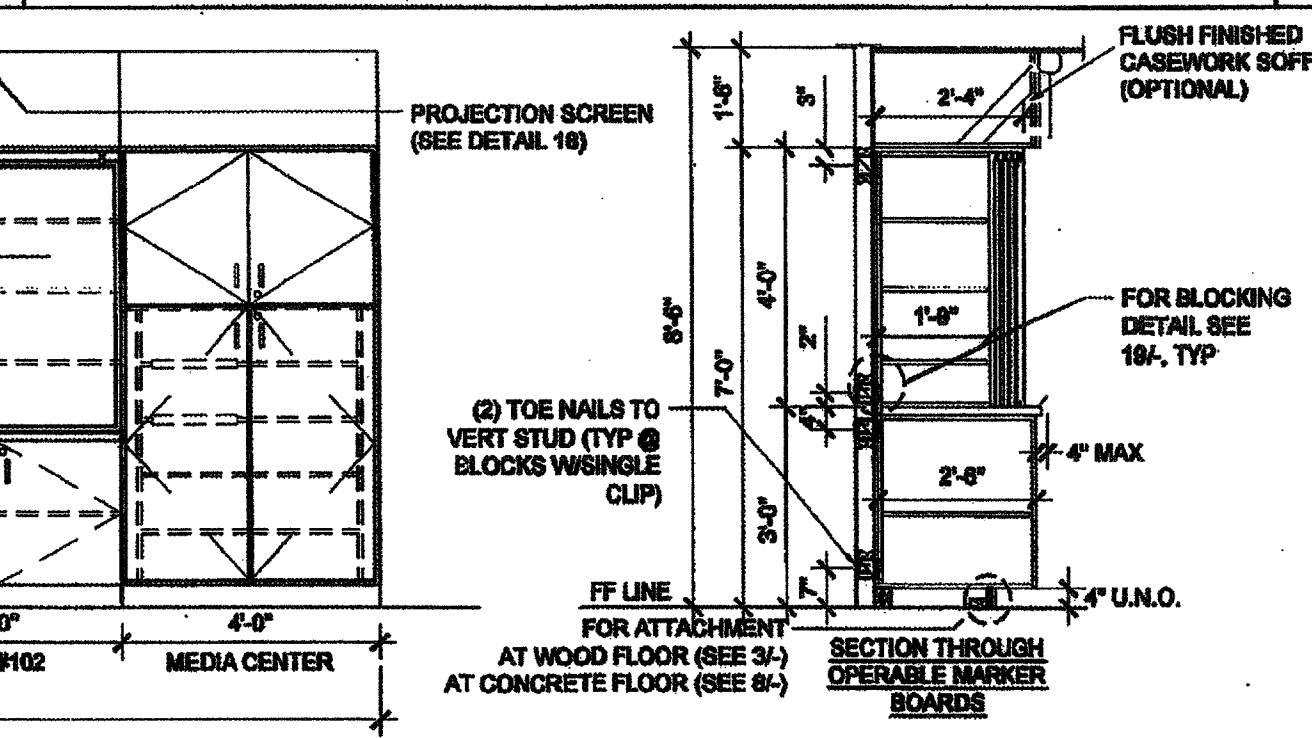

TALL CABINET WALL ANCHORAGE SCALE: 1 1/2" = 1'-0" 10

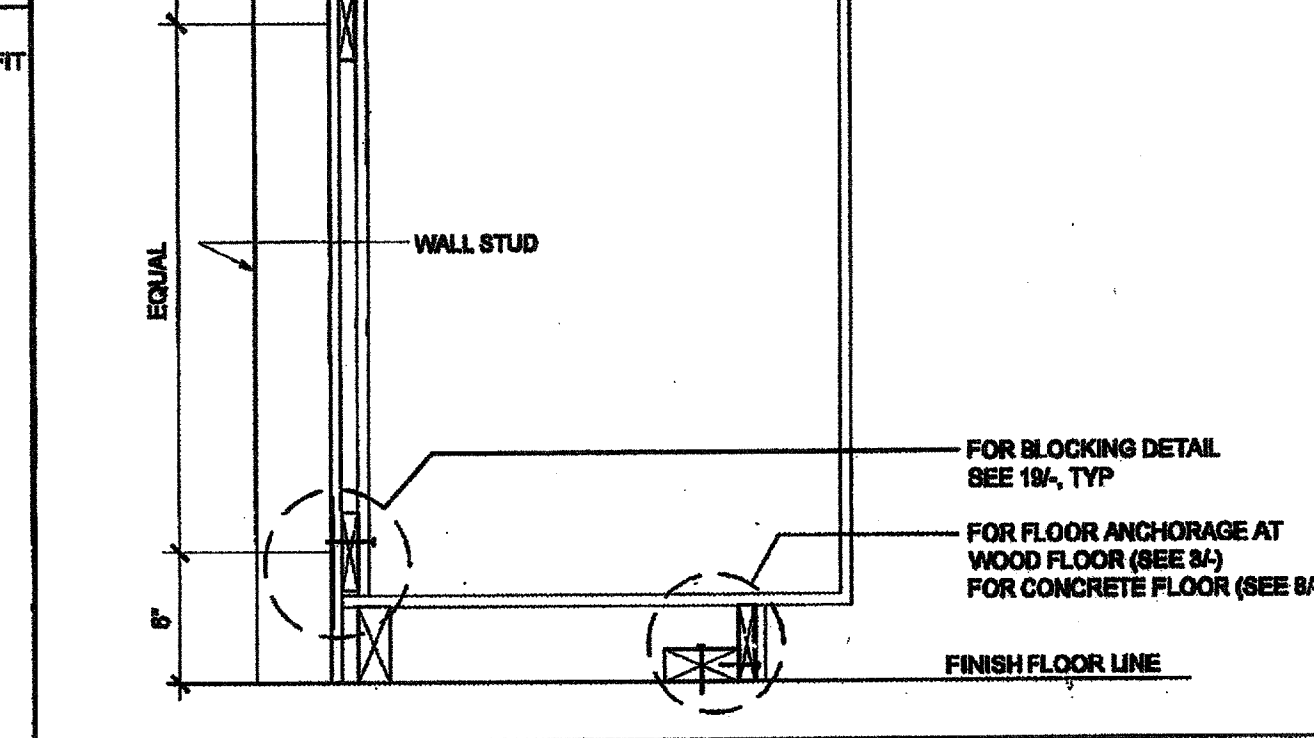

WALL HUNG ANCHORAGE CABINET SCALE: 1 1/2" = 1'-0" 5

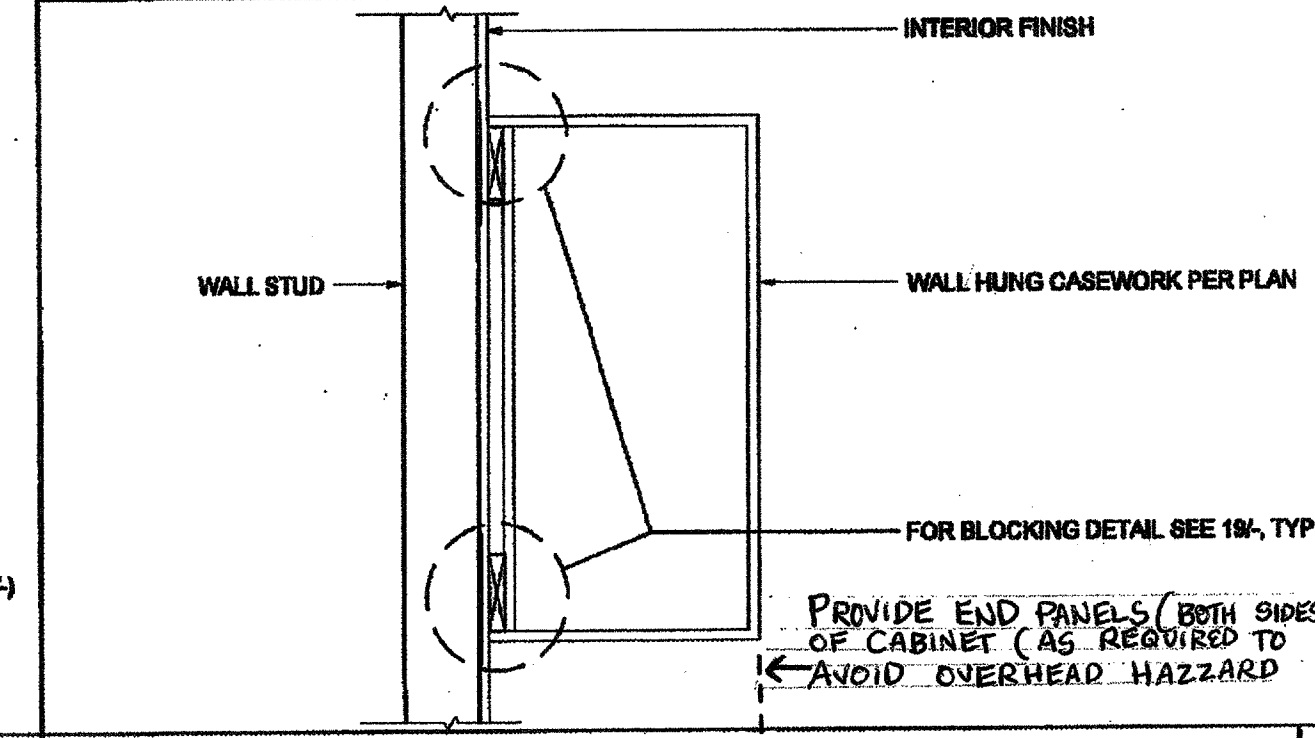

BASE CABINET WALL ANCHORAGE SCALE: 1" = 1'-0" 4