

INTERIOR PARTITION SCALE: 3" = 1'-0" 14

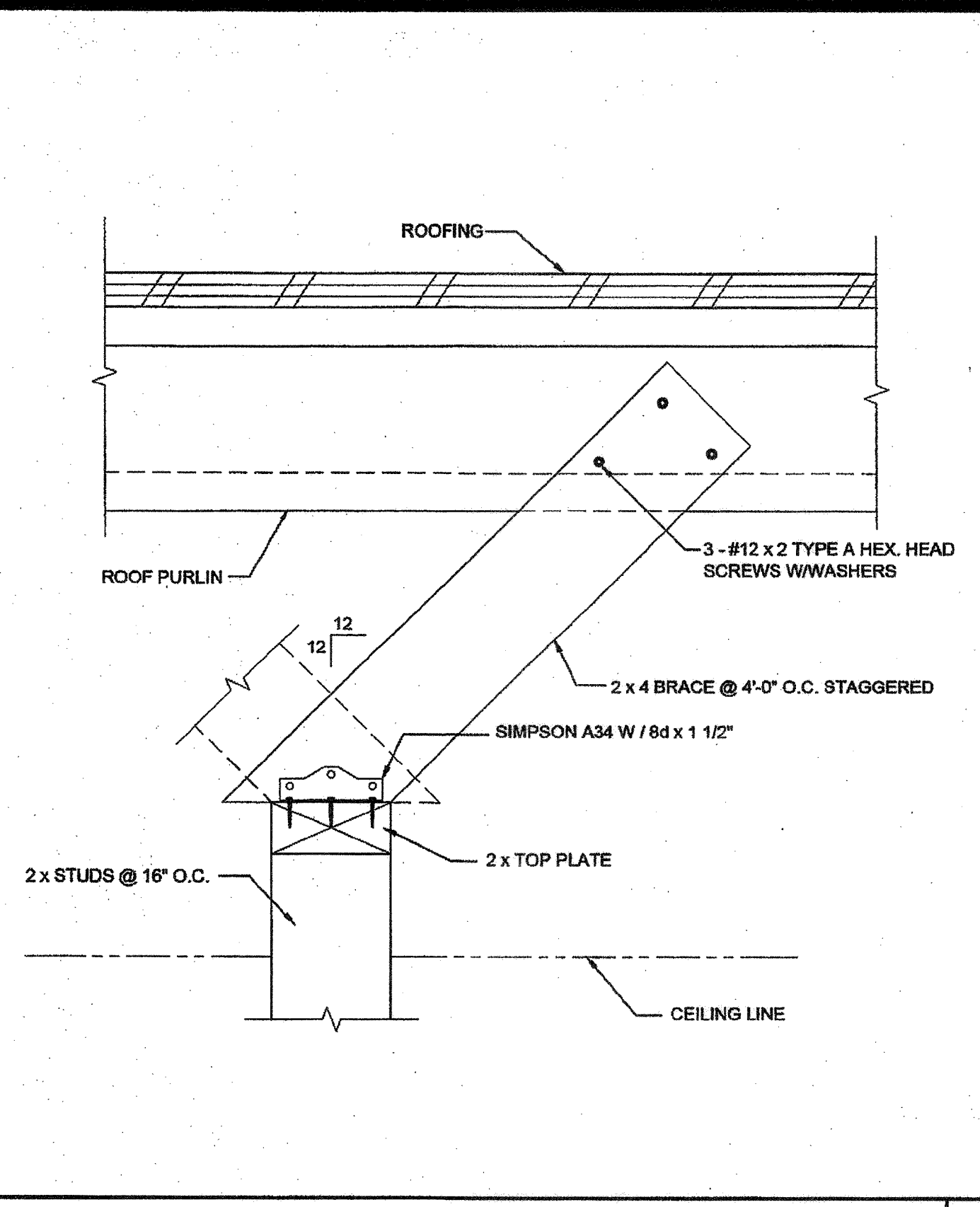

INTERIOR PARTITION SCALE: 3" = 1'-0" 12

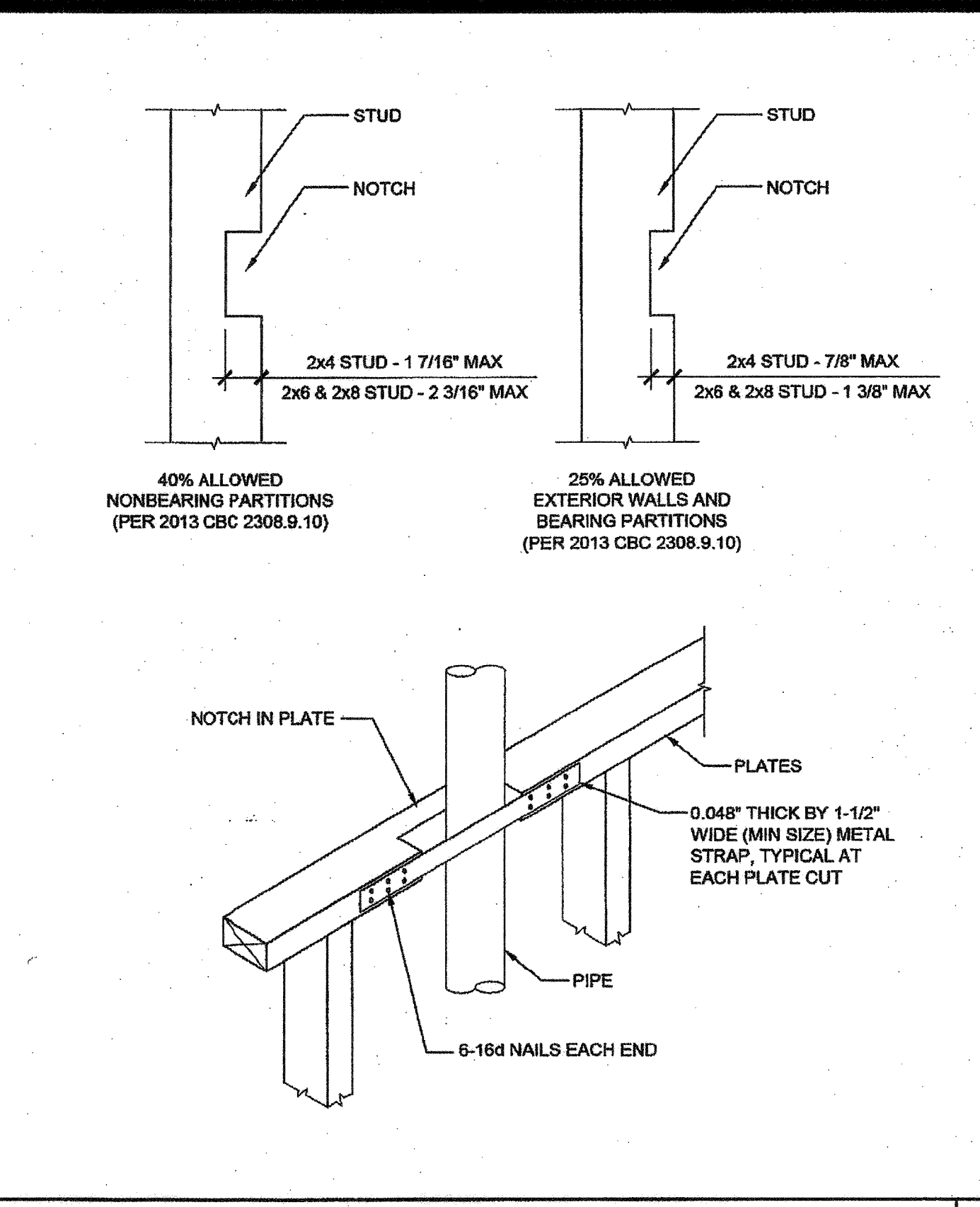

CUTTING AND NOTCHING SCALE: 1 1/2" = 1'-0" 7

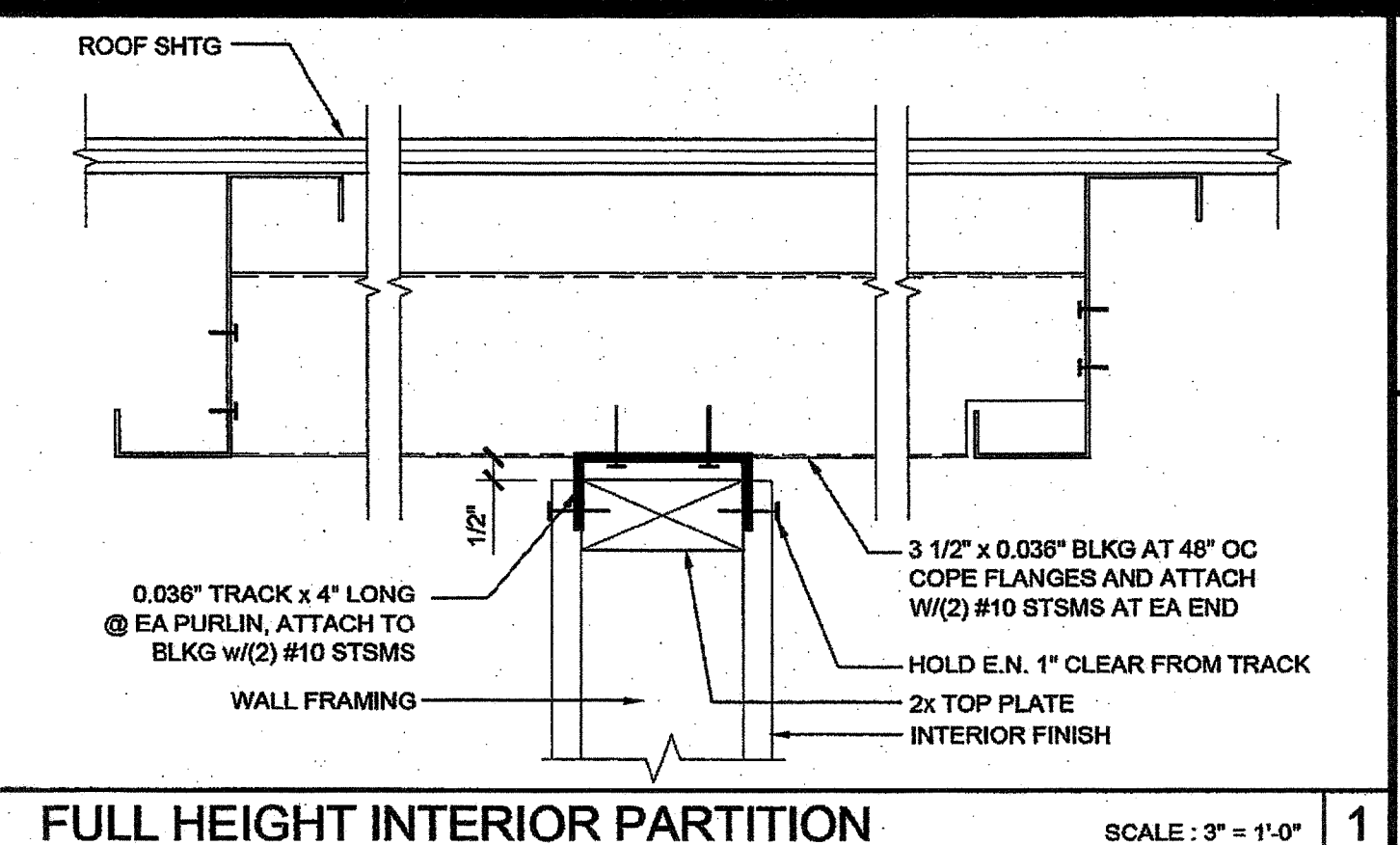

FULL HEIGHT INTERIOR PARTITION SCALE: 3" = 1'-0" 1

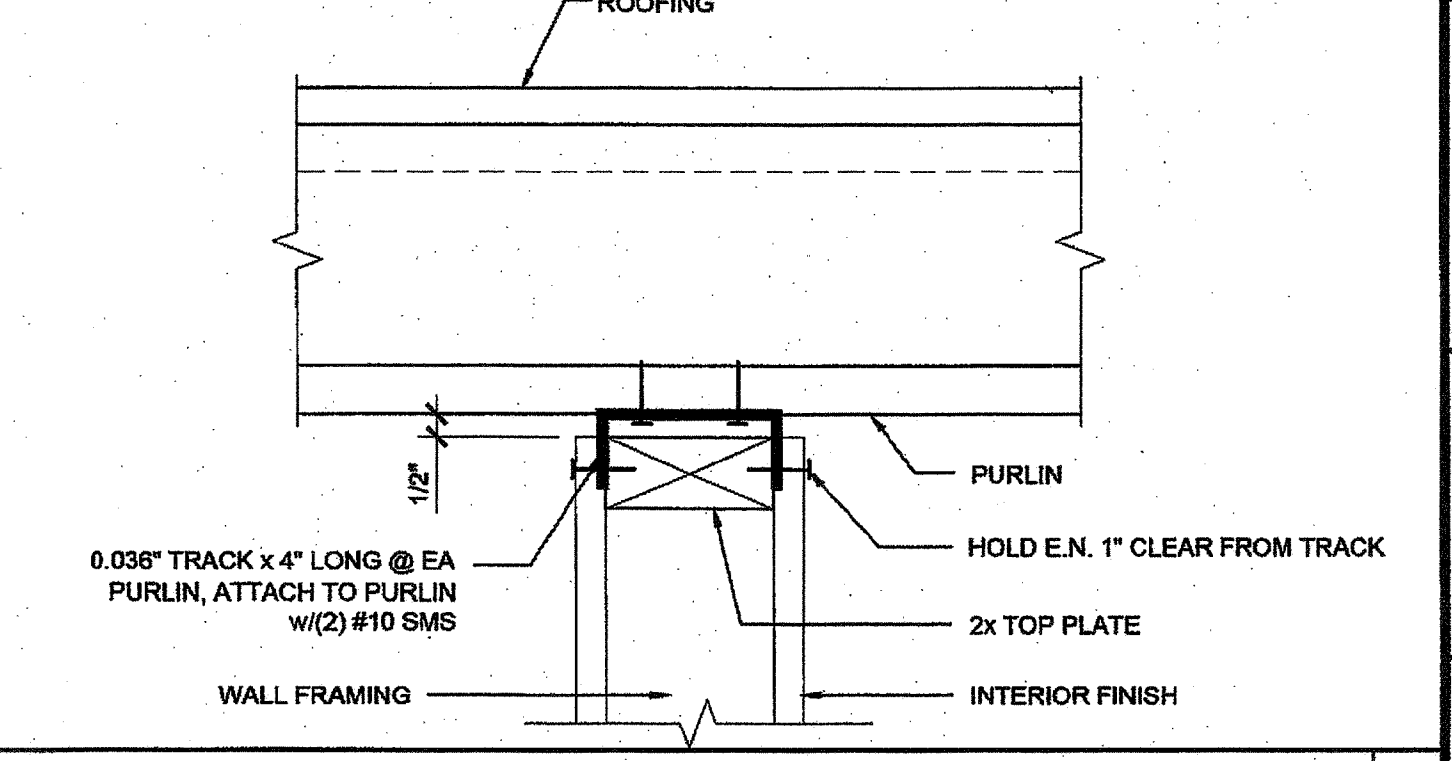

FULL HEIGHT INTERIOR PARTITION SCALE: 3" = 1'-0" 2

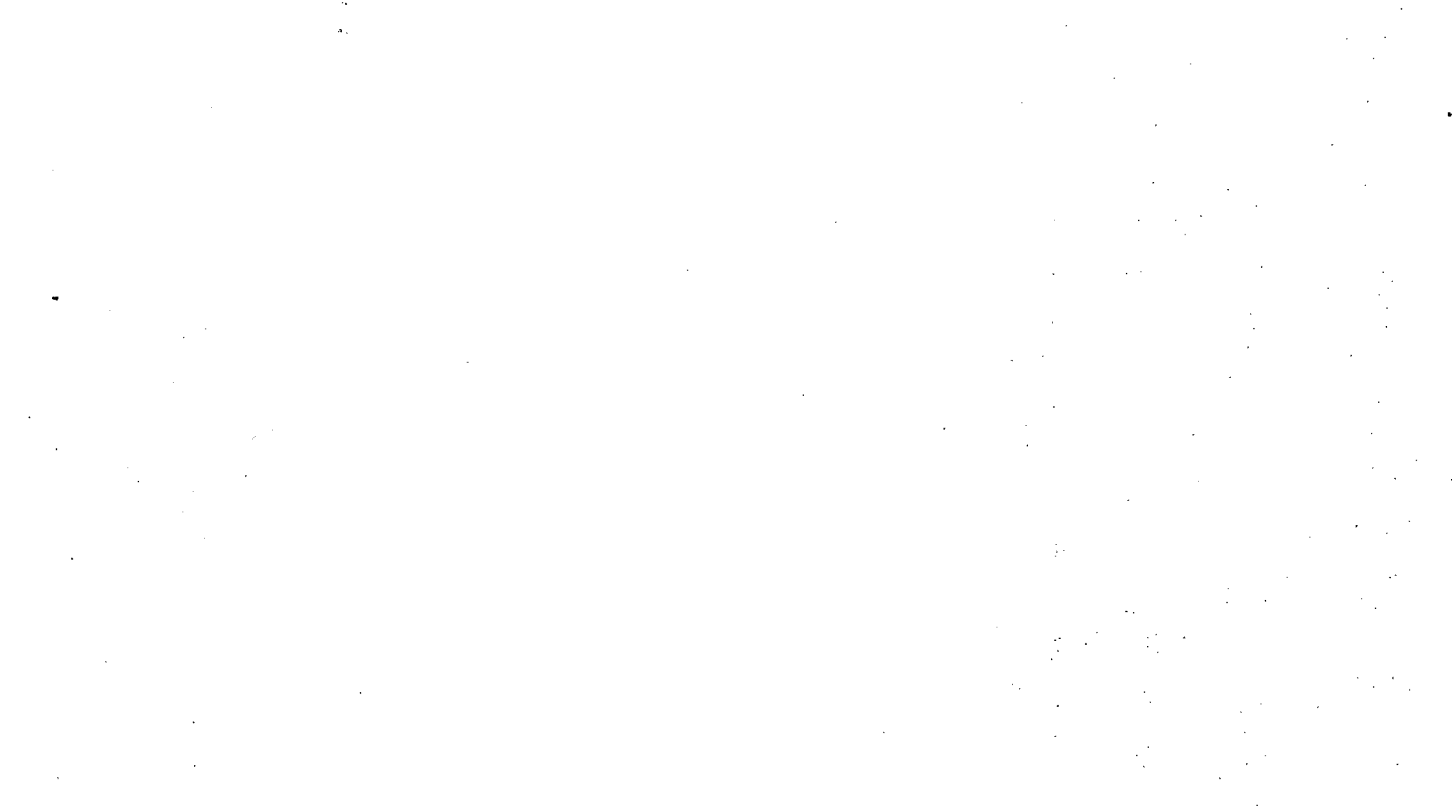

INTERIOR PARTITION WALL TO ROOF BEAM SCALE: 3" = 1'-0" 3



BORED HOLES SCALE: 1 1/2" = 1'-0" 8

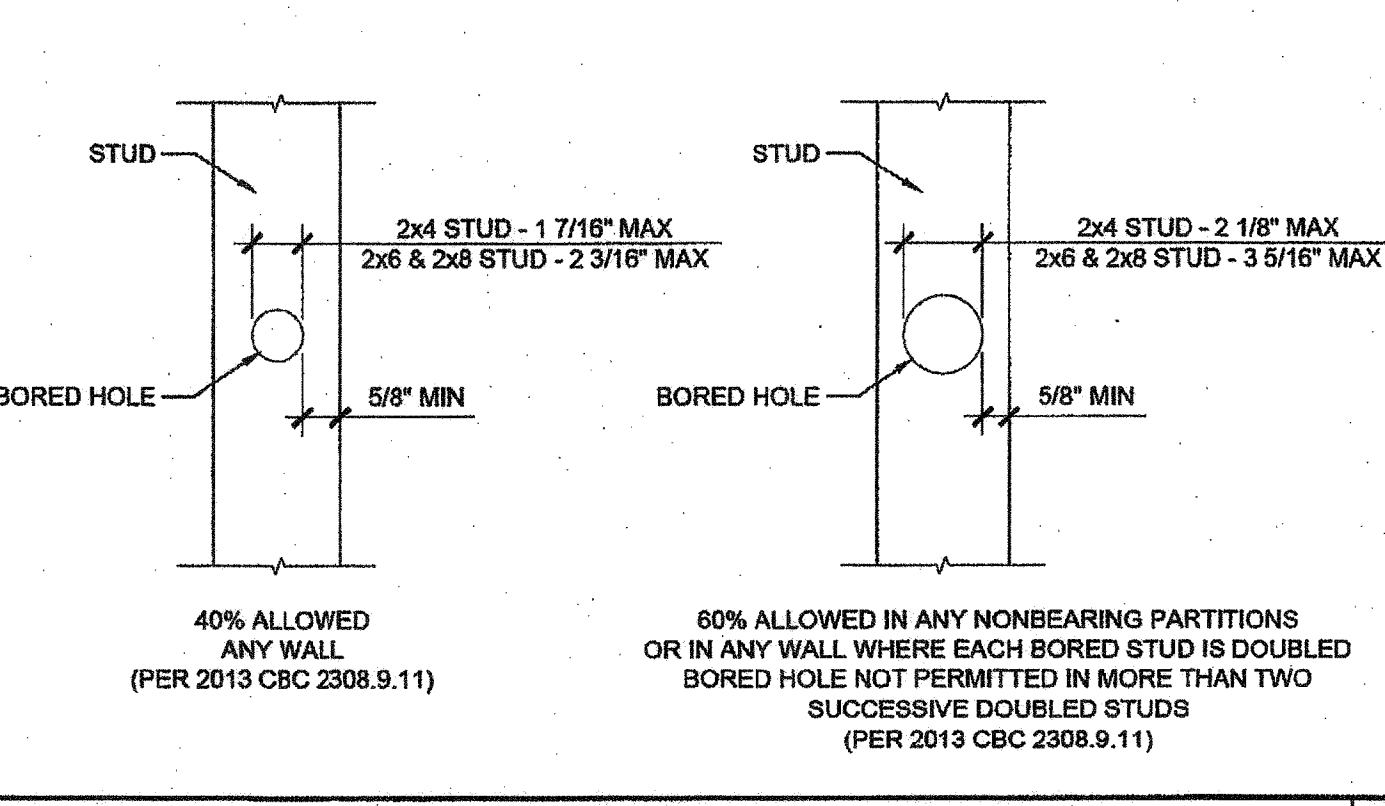

INTERIOR PARTITION WALL TO ROOF BEAM SCALE: 3" = 1'-0" 3



NOT USED 9



NOT USED 4



NOT USED 10



NOT USED 5

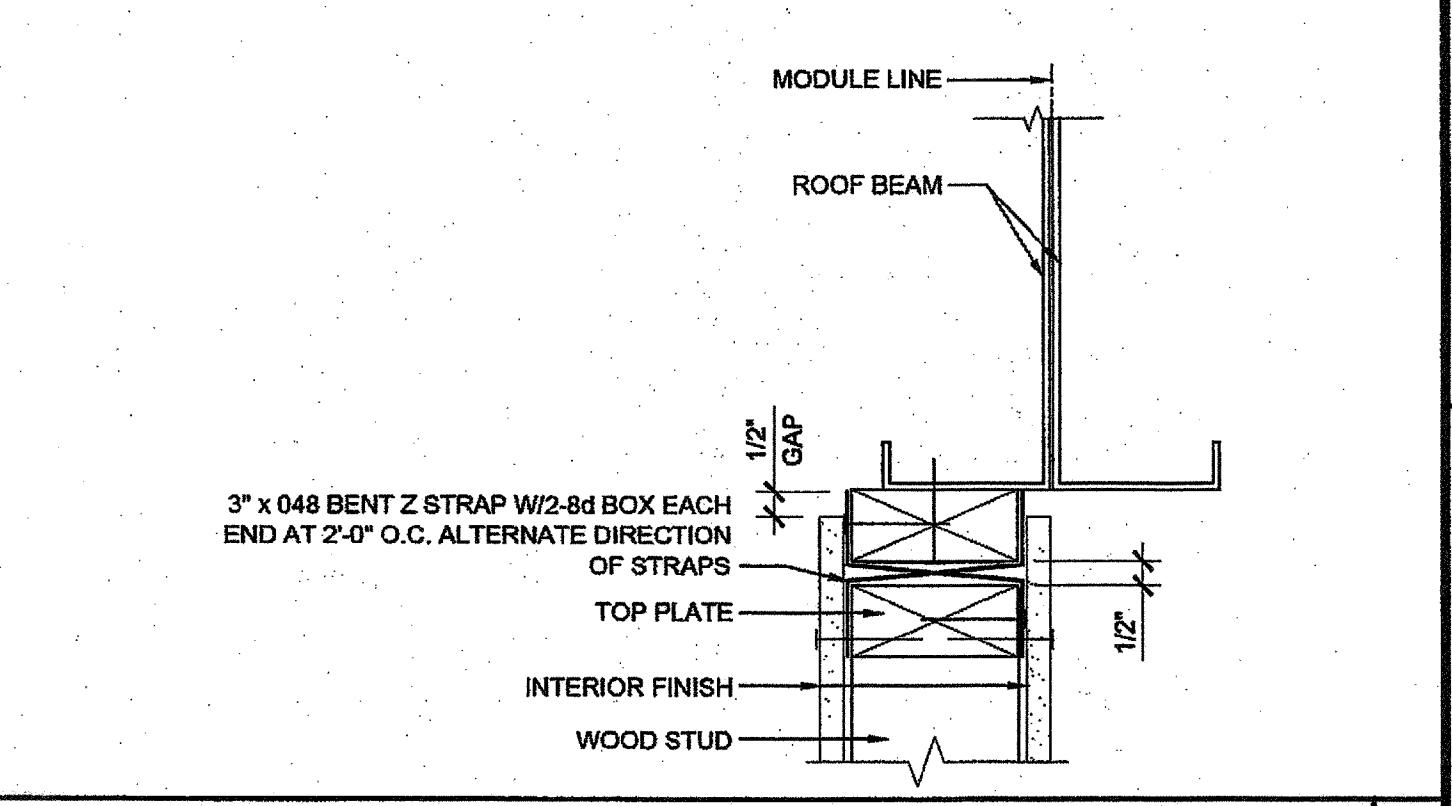

NOT USED 4

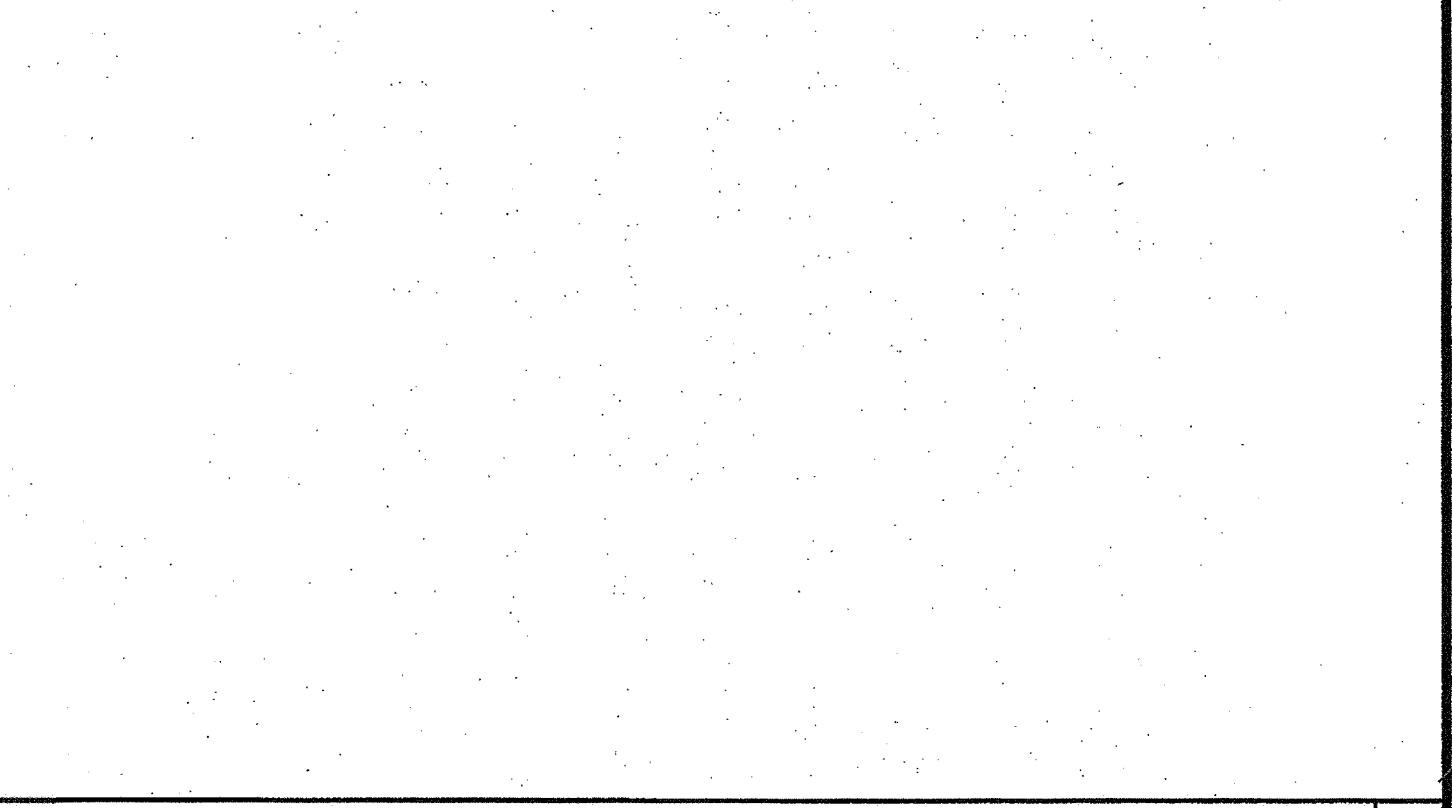

NOT USED 4

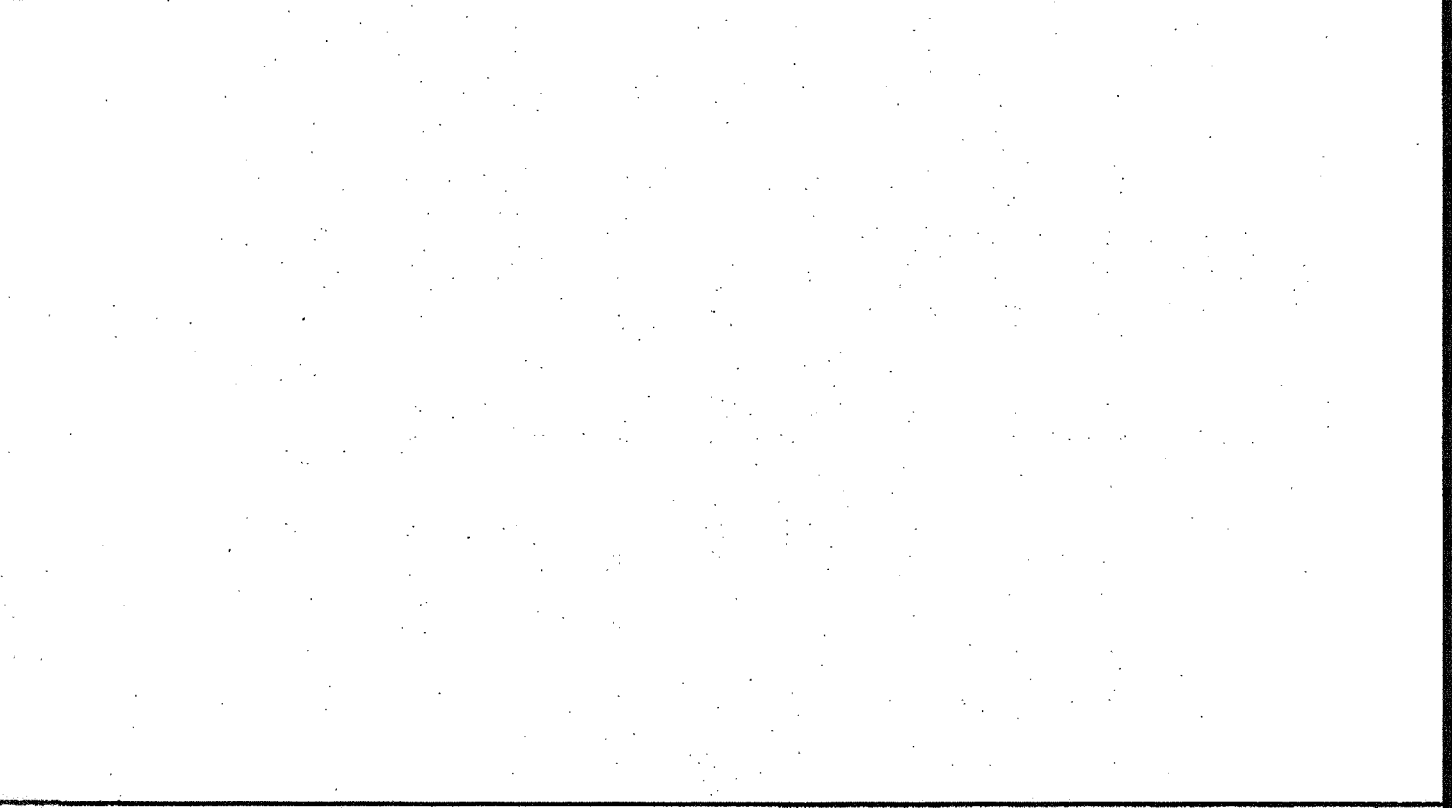

NOT USED 5

THESE DRAWINGS AND ALL MATERIAL CONTAINED HEREIN ARE THE PROPERTY OF SILVERCREEK INDUSTRIES, INC (SCI Inc) AND SHALL NOT BE REPRODUCED, COPIED OR OTHERWISE DISPOSED OF DIRECTLY OR INDIRECTLY AND SHALL NOT BE USED IN WHOLE OR IN PART TO ASSIST IN THE MAKING OF OR FOR THE PURPOSE OF FURNISHING ANY INFORMATION FOR THE MAKING OF DRAWINGS, PRINTS, APPARATUS OR PARTS THEREOF WITHOUT THE FULL KNOWLEDGE AND WRITTEN CONSENT OF SCI Inc. ALL PATENTABLE MATERIAL CONTAINED HEREIN AND ORIGINATING WITH SCI Inc SHALL BE THE PROPERTY OF SCI Inc

SILVER CREEK INDUSTRIES, INC.

"BUILDING FOR THE NEXT GENERATION"

**SILVER CREEK**

2830 BARRETT AVE PERRIS, CALIFORNIA 92571  
PHONE: 951-943-5383 FAX: 951-943-2211

PROJECT NAME:  
**24x40 STOCKPILE OFFICE BUILDING**

SHEET TITLE:  
**WALL FRAMING DETAILS WOOD STUDS**

STAVRES ASSOCIATES  
ARCHITECTS

ARCHITECT OF RECORD  
SUBMISSION DATE  
06/15/15

FILE # 15-5  
IDENTIFICATION STAMP  
DIV. OF THE STATE ARCHITECT  
OFFICE OF REGULATION SERVICES  
03-118270  
AC: [Signature] FLS: [Signature] SS: [Signature] RAE  
DATE: MAY 10 2017  
TRACKING #: 63221-290

PROJECT SPECIFIC STATE AGENCY APPROVAL

IDENTIFICATION STAMP  
DIV. OF THE STATE ARCHITECT  
04 11 6284  
AC: [Signature] FLS: [Signature] SS: [Signature] RAE  
DATE: MAY 10 2017

ORIGINAL PC STATE AGENCY APPROVAL

PRE-CHECK (PC) DOCUMENT  
A SEPARATE PRELIMINARY APPLICATION FOR CONSTRUCTION PERMIT IS REQUIRED

IDENTIFICATION STAMP  
DIV. OF THE STATE ARCHITECT  
OFFICE OF REGULATION SERVICES  
PC 04-114102  
AC: [Signature] FLS: [Signature] SS: [Signature] RAE  
DATE: AUG - 4 2015

REVISIONS

SILVER CREEK INDUSTRIES  
24' x 40' PC - 2:12 PITCH

PROJECT NO:  
DRAWN BY:  
SCALE: AS NOTED  
DATE: 01-30-15

P.C. SHEET NUMBER  
**S-5.11**