

Scale bars: 1" = 40'-0", 1" = 30'-0", 1" = 20'-0", 1/8" = 1'-0", 1/4" = 1'-0".

Ownership of Documents. This document, the ideas and designs incorporated herein, as an instrument of Professional Service is the property of Integrated Designs by SOMAM Inc. and is not to be used, in whole or in part for any other project without written authorization. © COPYRIGHT 2014

# 3 RELOCATABLE CLASSROOMS

## FREMONT ELEMENTARY SCHOOL

### BAKERSFIELD CITY SCHOOL DISTRICT

#### 607 TEXAS ST.

#### BAKERSFIELD, CA 93307

**integrated designs** by SOMAM, Inc.  
ARCHITECTURE - ENGINEERING - INTERIOR DESIGN - CONSTRUCTION MANAGEMENT  
601 N. Fresno, Suite 130 - Fresno, California 93710  
Phone (559) 436-0887 Fax (559) 436-0887 E-Mail: design@somam.com  
www.integrateddesigns.com

Revision	Description	Rev. Date

SCANNED

ABBREVIATIONS			
ABOVE FINISHED FLOOR ABV ACCESSIBLE A.C.C. ACOUSTICAL ADJ. ADJUSTABLE ADJUST. AIR CONDITIONING ALUM. ANCHOR BOLT ANCHOR BOLT ANDODZED ARCHITECTURAL ASPHALT CONCRETE A.C.  BACKBOARD BEAM BENCH MARK BTWN BLK. BOTTOM BUILDING BLDG.  CABINET CADMIUM CARPET CARRIAGE BOLT CAST IRON CEILING CEILING DIFFUSER CEILING GRILLE CEILING REGISTER CEM. CENTERLINE CERAMIC TILE CIRCUIT CLEANOUT CLR. COLD WATER COLJUN COMBINATION/COMPOSITE CONCRETE CONCRETE MASONRY UNIT CONNECTION CONSTRUCTION JOINT CONTINUOUS CONTRACTOR COORDINATE COUNTERSINK  DEPARTMENT DEPTH, DEEP DETAL DIAGONAL DIAMETER DIMENSION DISPENSER/DISPOSAL DIVISION DOOR DOUBLE DOWN DOWNSPOUT DRAWING DRINKING FOUNTAIN	ABV A.F.F. A.C.C. ACOUST. ACT. ADJ. ADJUSTABLE ADJUST. AIR COND. ALUM. ALUM. ANCHOR BOLT ANCHOR BOLT ANDODZED ARCH. A.C.  BACKBRD. BM B.M. BTWN BLK. BTM. BLDG.  CAB. CAD. CPT. C.B. CAST IRON CLG. C.C. C.G. C.R. CEM. C.L. C.T. CR. C.O. CLR. C.W. COLJ. COMB. CONC. CONC. COND. CONN. CONSTR. CONSTR. CONT. CONTR. COORD. CSK.  DEPT. D. DET. DIAG. DIA. DIM. DISP. DIV. DR. DBL. DN. D.S. DRWC. D.F.	EACH ELECTRIC ELECTRIC DRINKING FOUNTAIN ELEVATION EQUA. EQUIP. ESTIMATE EXHAUST EXHAUST FAN EXISTING EXPANSION EXPANSION JOINT EXT.  FABRIC WALL COVERING FACE OF BLOCK FACE OF CONCRETE FACE OF STUD FACE OF WALL FACTORY FINISH FEET/FOOT FEMINE NAPKIN DISPOSAL FINISH FINISH GLASS FIRE EXTINGUISHER CABINET FIRE RATED GYP. BD. FIXED GLASS FLAT HEAD FLOOR FLOOR DRAIN FLUORESCENT FLUOR. FTG. FOUND. FRAMING  GAGE/GAUGE GALVANIZE GALVANIZED IRON GLASS GRAB BAR GRADE GROUND GYP. GYPSUM BOARD	EA. ELEC. E.D.F. ELEV. EQUA. EQUIP. EST. EXH. E.F. E.F. E.P. E.X. EXT.  F.W.C. F.O.B. F.O.C. F.O.S. F.O.W. F.F. FT. F.D. F.G. FIBERGL. FIN. F.E.C. F.R.G.B. F.C. F.D. FLR. F.L. FLUR. FTG. FDN. FRM.G.  GA. CALV. GL. GL. GL. GR. GR. GR. GYP. GYP.BD.  HARDWARE HD. HDR. HT. H.M. HORIZ. HOT WATER HOSE BIBB

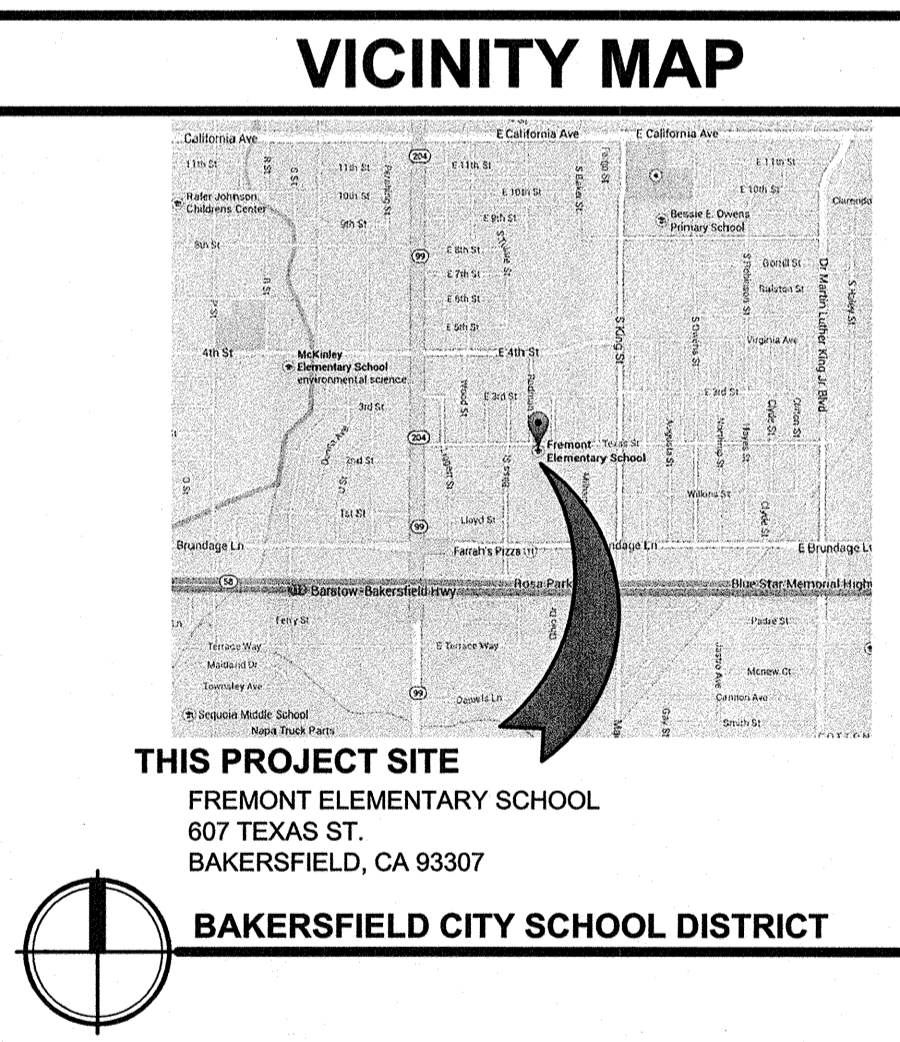

SHEET INDEX	
SHT. NO.	DESCRIPTION
GENERAL	
T1.01	TITLE SHEET
ARCHITECTURAL	
A1.01	SITE PLAN
A1.01 FMA	REFERENCE SITE PLAN - FIRE MARSHAL APPROVED
A1.02	ENLARGED SITE PLAN
A1.03	SITE DETAILS
ELECTRICAL	
E-1	SITE PLAN - ELECTRICAL
E-2	POWER AND SIGNAL PLAN
E-3	FIRE ALARM PLAN
E-4	DETAILS AND SYSTEM DIAGRAMS

### GENERAL NOTES

- ALL WORK SHALL CONFORM TO TITLE 24, CALIFORNIA CODE OF REGULATIONS
- CHANGES MADE TO THE APPROVED DRAWINGS AND SPECS SHALL BE MADE BY ADDENDUM OR C.C.D., APPROVED BY DSA AS REQUIRED BY SECTION 4-338, PART 1, TITLE 24, C.C.R.
- GRADING PLANS, DRAINAGE IMPROVEMENTS, ROADS AND ACCESS REQUIREMENTS AND ENVIRONMENTAL HEALTH CONSIDERATIONS SHALL COMPLY WITH ALL LOCAL ORDINANCE
- THE FOLLOWING SHALL BE ON THE JOB SITE PRIOR TO THE INSTALLATION OF THE UNIT, INCLUDING THE SERIAL NUMBER FOR EACH UNIT.  
A. IN-PLANT FINAL VERIFIED REPORT  
B. WELDING VERIFIED REPORT
- REFER TO RELOCATABLE BUILDING MANUFACTURER'S DRAWINGS FOR ALL INFORMATION REGARDING THE RELOCATABLE BUILDINGS

### SCOPE OF WORK

- RELOCATION OF (3) PORTABLE CLASSROOM BUILDINGS AND METAL RAMPS AND CONSTRUCTION OF UTILITY SERVICES ON AN EXISTING ELEMENTARY SCHOOL CAMPUS.
- CLASSROOMS TO BE RELOCATED FROM AN OFF-SITE STOCKPILE AND TO BE USED STRICTLY FOR TEMPORARY USE.
- CONSTRUCTION OF WOOD FOUNDATIONS FOR (3) PORTABLE BUILDINGS

### BUILDING DATA

OCCUPANCY = E  
TYPE OF CONSTRUCTION = VB (NON-SPRINKLERED)  
TEMP CLASSROOMS  
3 (N) CLASSROOMS @ 960 S.F. (24'x40') EA. = 2,880 S.F.  
6 (E) CLASSROOMS @ 960 S.F. (30'x32') EA. = 5,760 S.F.  
3 (N) OVERHANGS @ 120 S.F. EA. = 360 S.F.  
6 (E) OVERHANGS @ 150 S.F. EA. = 900 S.F.  
**TOTAL = 9,900 S.F.**

PER 2013 C.B.C. TABLE 503:  
ALLOWABLE AREA = 9,500 S.F.  
9,900 PROPOSED > 9,500 ALLOWABLE = AREA INCREASE REQUIRED

AREA INCREASE (CBC SECTION 506)  
AREA INCREASE =  $A_2 \times (A_1 \times I_1) + (A_1 \times I_2)$   
 $(2-SIDES) \quad I_1 = \frac{(F/P - 0.25) V}{30}$   
AREA INCREASE =  $\frac{9500 \times (9500 \times 0.25) + 11,875 \times 9.75}{30}$   
 $(2 \text{ SIDES}) \quad \frac{(266632 + 0.25) 90 + 0.25}{30}$   
9,900 PROPOSED < 11,875 ALLOWABLE = OK

### ARCHITECT'S STATEMENT

ARCHITECT'S STATEMENT FOR PLANS PREPARED BY OTHER LICENSED DESIGN PROFESSIONALS AND/OR CONSULTANTS

THESE DRAWINGS AND/OR SPECIFICATIONS AND/OR CALCULATIONS FOR THE ITEMS LISTED IN THE SHEET INDEX AND CHECKED BELOW HAVE BEEN PREPARED BY OTHER DESIGN PROFESSIONALS OR CONSULTANTS WHO ARE LICENSED AND/OR AUTHORIZED TO PREPARE SUCH DOCUMENTS IN THIS STATE. THESE DOCUMENTS HAVE BEEN EXAMINED BY ME FOR DESIGN INTENT AND HAVE BEEN FOUND TO MEET THE APPROPRIATE REQUIREMENTS OF TITLE 24, CALIFORNIA CODE OF REGULATIONS AND THE PROJECT SPECIFICATIONS PREPARED BY ME.

THE ITEMS CHECKED BELOW ARE ACCEPTABLE FOR INCORPORATION INTO THE CONSTRUCTION OF THIS PROJECT FOR WHICH I AM THE INDIVIDUAL DESIGNATED TO BE IN GENERAL RESPONSIBLE CHARGE (OR FOR WHICH I HAVE DELEGATED RESPONSIBILITY FOR THIS PORTION OF THE WORK)

SEE THE SHEET INDEX ON THIS SHEET FOR DRAWINGS OTHER THAN ARCHITECTURAL.

APPLICABLE:  
 STRUCTURAL  PLUMBING  MECHANICAL  ELECTRICAL  
 PORTABLE MANUFACTURER  CIVIL

Inspector of Record: **7/22/14**  
Signature: *[Signature]*  
Name: CURTIS E. FLYNN, ARCHITECT, INTEGRATED DESIGNS BY SOMAM, INC.  
License: **C-28966**  
Expiration Date: **05-31-15**

### SYMBOLS

- SECTION KEY: SECTION IDENTIFICATION SHEET NUMBER
- DETAIL KEY: DETAIL NUMBER SHEET NUMBER
- INTERIOR ELEVATION KEY: ELEVATION DIRECTION ELEVATION IDENTIFICATION SHEET NUMBER
- ELEVATION DATUM: INDICATES HEIGHT IN RELATION TO 0'-0"
- ROOM NUMBER / FINISH TAG: ROOM NAME ROOM NUMBER
- WINDOW SCHEDULE KEY
- KEYNOTE SCHEDULE KEY
- DOOR SCHEDULE KEY

Stamp(s):

Job No.: **5124**

Sheet No.: **T1.01**

Release: -

**TITLE SHEET**

**3 RELOCATABLE CLASSROOMS**

**FREMONT ELEMENTARY SCHOOL**

BAKERSFIELD CITY SCHOOL DISTRICT  
607 TEXAS ST. BAKERSFIELD, CA 93307

APPROX. 1:50:00  
AC. PLAN 150.00 SS. JB  
DATE: 7/24/14

Stamp: **SCANNED**

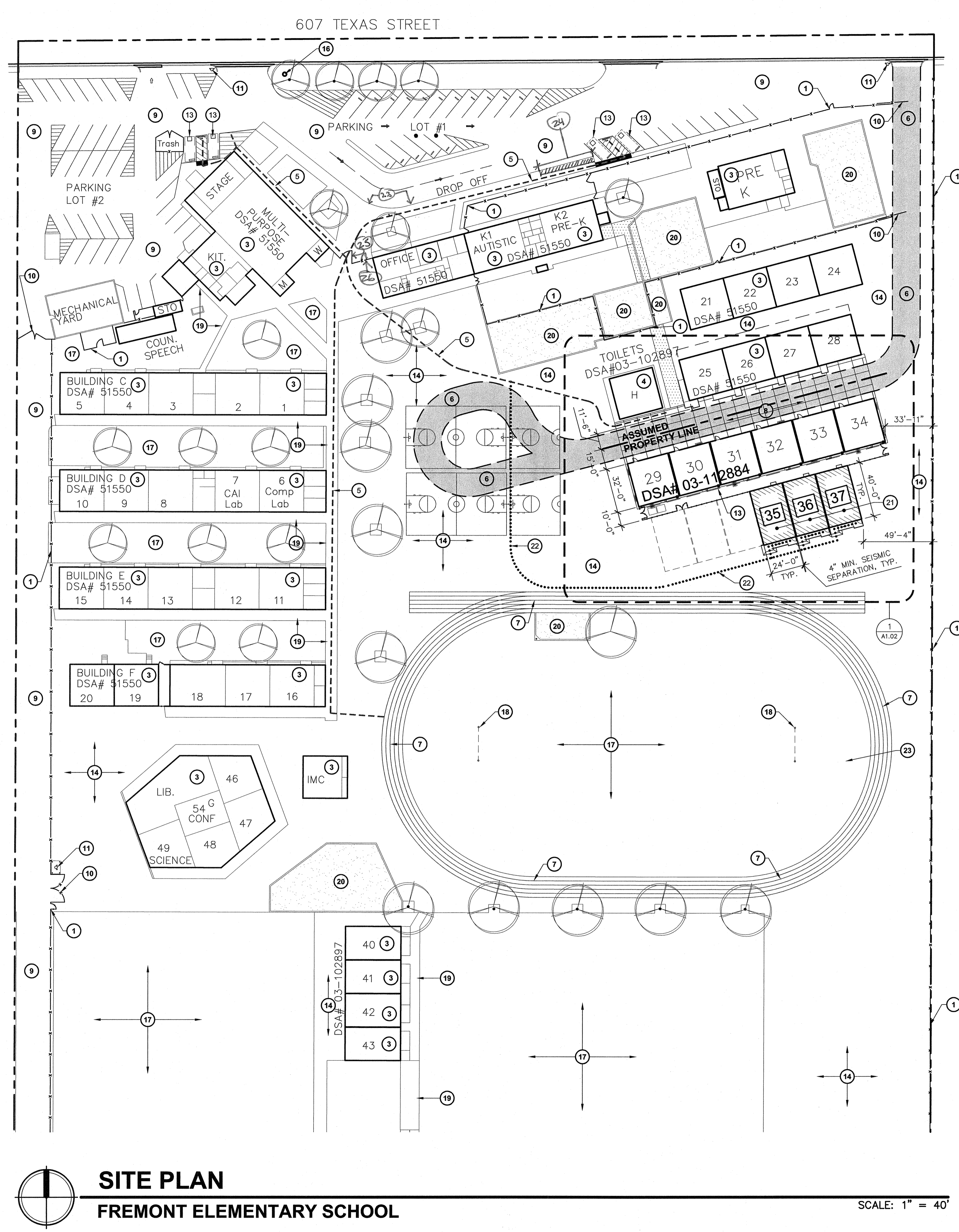
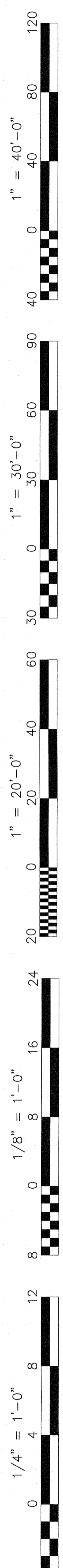

**SITE PLAN**  
**FREMONT ELEMENTARY SCHOOL**

SCALE: 1" = 40'

**GENERAL NOTES**

- A. GENERAL CONTRACTOR SHALL FIELD VERIFY ALL SITE CONDITIONS PRIOR TO BID. IF ANY DISCREPANCIES ARE FOUND, THE ARCHITECT SHALL BE NOTIFIED IN WRITING.
- B. CONTRACTOR SHALL BE RESPONSIBLE FOR THE CORRECTNESS OF LAYOUTS AND ESTABLISHING LOCATIONS OF BURIED UTILITY LINES. ANY UTILITIES REQUIRING RELOCATION SHALL BE THE RESPONSIBILITY OF THE GENERAL CONTRACTOR CONTACT APPLICABLE GOVERNING AGENCIES REGARDING ARRANGEMENT AND COORDINATION OF WORK.
- C. GENERAL CONTRACTOR WILL BE RESPONSIBLE FOR ANY COMPACTION RETEST DUE TO INITIAL FAILURE.
- D. PROJECT INSPECTOR SHALL BE EMPLOYED BY THE OWNER, APPROVED BY THE RESPONSIBLE ARCHITECT AND DSA.
- E. A COPY OF TITLE-24, ALL PARTS APPLICABLE, TO BE KEPT AT THE JOB SITE AT ALL TIMES.
- F. ADDENDA SHALL BE SIGNED BY THE ARCHITECT (RESPONSIBLE IN CHARGE) AND APPROVED BY DSA.
- G. C.C.D.s SHALL BE SIGNED BY THE ARCHITECT (RESPONSIBLE IN CHARGE), OWNER AND APPROVED BY DSA.
- H. TESTING LAB SHALL BE EMPLOYED BY THE OWNER, APPROVED BY THE RESPONSIBLE ARCHITECT AND DSA.
- I. ALL WORK SURFACES DISTURBED OR DAMAGED BY THE CONSTRUCTION ACTIVITIES SHALL BE REPAIRED IN KIND, TEXTURED AND FINISHED TO MATCH ADJACENT SURFACES.
- J. NEW CONCRETE WALKS SHALL HAVE SLOPES NOT TO EXCEED 1 IN 20 IN THE DIRECTION OF PATH OF TRAVEL. PROVIDE CONTROL JOINTS ("C.J.") AT 5'-0" O.C. MAX. AND EXPANSION JOINTS NOT TO EXCEED 30'-0" MAX. PROVIDE MEDIUM BROOM FINISH ON ALL WALKS.
- K. ALL BUILDING AND ROOM NAMES INDICATED ON THESE CONSTRUCTION DOCUMENTS ARE "NOT" THE ACTUAL BUILDING/ ROOM SIGNAGE DESIGNATION. THE GENERAL CONTRACTOR SHALL FURNISH, INSTALL AND COORDINATE ALL REQUIRED SIGNAGE WITH THE OWNER/ARCHITECT PRIOR TO STARTING CONSTRUCTION.
- L. GENERAL CONTRACTOR WILL BE RESPONSIBLE TO COORDINATE RELOCATABLE BUILDING DELIVERY DATES TO THE SCHOOL SITE WITH THE MFG.
- M. THE GENERAL CONTRACTOR SHALL CONSTRUCT ALL NEW RELOCATABLE BUILDING FOUNDATIONS AS PER THE RELOCATABLE BUILDING MANUFACTURER'S DRAWINGS AND SPECIFICATIONS.
- N. THE GENERAL CONTRACTOR SHALL BE RESPONSIBLE TO PROVIDE ALL HOOK-UPS TO THE RELOCATABLE BUILDINGS AFTER INSTALLATION HAS BEEN COMPLETED BY THE MANUFACTURER.
- O. 5'-0" DEEP x 5'-0" WIDE MINIMUM LANDINGS AT DOORWAYS SHALL BE AS DETAILLED AND SHALL HAVE SLOPES (IN ANY DIRECTION) OF NOT GREATER THAN 1/4 IN 12 SLOPE. SLOPES SHALL BE AWAY FROM DOORWAYS.
- P. GENERAL/SITE CONTRACTOR SHALL FIELD VERIFY THAT EXISTING PATH OF TRAVEL (P.O.T.) IS A MINIMUM OF 4'-0" WIDE AND IS SLIP RESISTANT. IF IT IS NOT, THEN THE CONTRACTOR SHALL NOTIFY THE ARCHITECT OF RECORD AND A REMEDY OR ALTERNATE P.O.T. WILL BE PROVIDED.
- Q. THE MAXIMUM DROP BETWEEN EXISTING FINISHED GRADES AND THE TOP OF THE P.O.T. SHOULD NOT EXCEED 4". IF IT DOES, PROVIDE THE NECESSARY WARNING CURB PER CBC SEC. 11B-303.5.

24. PROVIDE NEW TRUNCATED DOWNS 3 FT WIDE ALONG THE LENGTH OF SIDEWALK THAT IS FLUSH WITH THE AC PAVING PER DETAIL 11/A1.03

25. EXISTING GATE TO REMAIN LOCKED IN THE OPEN POSITION DURING SCHOOL HOURS.

26. PROVIDE NEW 4 FT WIDE GATE PER 15 & 16 / A1.03

**LOCAL FIRE AUTHORITY REVIEW**

DSA #10 LOCAL FIRE AUTHORITY REVIEW

To facilitate the Division of the State Architect's (DSA) approval of the FireLife Safety portion of a project, DSA requires Local Fire Authority (LFA) review of certain elements as identified in this form. Use of this form is mandatory for projects that are subject to the jurisdiction of the State Fire Marshal or the State Fire Marshal's Office.

**PROJECT INFORMATION**

Project Name: FREMONT ELEMENTARY SCHOOL  
 Project Address: 607 TEXAS ST., BAKERSFIELD, CA 93307  
 LFA Agency Name: \_\_\_\_\_

**LOCAL FIRE AUTHORITY (LFA)**

Reviewer Name:	Title:	Signature:	Date:

I have reviewed and approved the applicable items for this project as listed below.  
 Note: Only sign this form on the left side of the page. The signature on the right side is for the DSA.  
 LFA Reviewer's Signature: \_\_\_\_\_ Date: \_\_\_\_\_

Reviewer Key:	Y	N	NA	NR
1. Where an elevator does not meet medical emergency service call, use the California Building Code (CBC), use of stairways for emergency rescue and patient transport is acceptable.				
2. Access route, fire alarm, power and gas entrances are in accordance with Title 19, California Code of Regulations, & the California Code of Ordinances.				
3. Fire hydrant location and distribution complies with the California Fire Code (or see #6).				
4. Fire hydrant location and distribution complies with NFPA 1142, "Minimum Means", "1" NCI" standard. DSA can only verify the 1" NCI standard. The signature of the school district official is required to acknowledge use of alternate means.				
5. The installation of the proposed fire alarm indicator valve and fire department connection meet the requirements of this jurisdiction.				
6. The backflow(s) of the detector check valve assembly meet the requirements of this jurisdiction.				
7. In the project located in a hazard severity zone area (CBC, Chapter 7A, Section 701A). Check box "Y" for: <input type="checkbox"/> Moderate <input type="checkbox"/> High <input type="checkbox"/> Very High <input type="checkbox"/> NFPA (If one of these boxes is checked, the project design must meet the requirements of Chapter 7A.)				

COMMENTS (note deficiencies):

**KEYNOTES**

1. EXISTING CHAIN LINK FENCE AND GATE TO REMAIN
2. EXISTING ACCESSIBLE PARKING SIGNAGE, DSA# 03-102897, MOUNTED TO EXISTING C.L. FENCE
3. EXISTING BUILDING TO REMAIN, NO WORK
4. EXISTING ACCESSIBLE RESTROOM BUILDING PER DSA #03-102897, NO WORK
5. EXISTING ACCESSIBLE PATH OF TRAVEL TO REMAIN, VERIFY IN FIELD
6. EXISTING 20' WIDE FIRE TRUCK ACCESS LANE OVER EXISTING PAVING, APPROVED BY THE LOCAL JURISDICTION.
7. EXISTING TRACK STRIPING TO REMAIN
8. EXISTING CONCRETE WALK WITH MEDIUM BROOM FINISH
9. EXISTING A.C. PAVED PARKING LOT TO REMAIN
10. EXISTING 20' WIDE CHAIN LINK FIRE TRUCK ACCESS GATE. PROVIDE NEW KNOX PAD LOCK PER KERN COUNTY STANDARDS
11. EXISTING FIRE HYDRANT TO REMAIN
12. EXISTING PAIR OF 48" ACCESSIBLE GATES TO REMAIN LOCKED IN THE OPEN POSITION DURING SCHOOL HOURS
13. EXISTING ACCESSIBLE PARKING STALL PER DSA APPL. #03-112884
14. EXISTING A.C. PAVING TO REMAIN
15. PROVIDE 2" WIDE WHITE STRIPING WHERE REQUIRED TO MATCH WITH EXISTING TRACK CONFIGURATION WITHIN THE AREA OF THE NEW AC-PAVING
16. EXISTING TOW-AWAY SIGN MOUNTED TO EXISTING POLE PER DSA APPL. #03-112884
17. EXISTING TURF TO REMAIN, NO WORK
18. EXISTING GOAL POST TO REMAIN
19. EXISTING CONCRETE WALK TO REMAIN
20. EXISTING SAND BOX PLAY AREA TO REMAIN
21. NEW MODULAR CLASSROOM ON WOOD FOUNDATION w/ METAL RAMPS INSTALLED PER MANUFACTURER'S DRAWINGS
22. PROPOSED ACCESSIBLE PATH OF TRAVEL (P.O.T.) REFER TO ACCESSIBILITY NOTE, THIS SHEET

**PARKING CALCULATION**

**PARKING LOT #1**

TOTAL STALLS PROVIDED:	27
ACCESSIBLE STALLS REQUIRED PER CBC TABLE 11B-208.2:	2
VAN SPACES REQUIRED (1 PER 6 ADA):	1
ACCESSIBLE STALLS PROVIDED:	1 REGULAR 1 VAN 2 TOTAL

**PARKING LOT #2**

TOTAL STALLS PROVIDED:	37
ACCESSIBLE STALLS REQUIRED PER CBC TABLE 11B-208.2:	2
VAN SPACES REQUIRED (1 PER 6 ADA):	1
ACCESSIBLE STALLS PROVIDED:	1 REGULAR 1 VAN 2 TOTAL

**ACCESSIBILITY NOTES**

- ARCHITECT HAS INSPECTED THE PATH OF TRAVEL (P.O.T.) AS INDICATED ON THE PLANS AND HAS FOUND IT TO BE, OR HAS INDICATED ON THE PLANS REMEDIAL WORK WHICH WOULD CAUSE IT TO BE, A BARRIER-FREE ACCESSIBLE ROUTE.
- AT LEAST 48" IN WIDTH; OR AS APPROVED BY CODE
  - FREE OF ABRUPT LEVEL CHANGES EXCEEDING 1/4" IF BEVELED AT 1:2 MAX SLOPE, OR VERTICAL LEVEL CHANGES EXCEEDING 1/4"
  - WITH A FIRM, STABLE, AND SLIP RESISTANT WALKING SURFACE
  - WITH A RUNNING SLOPE OF 1:20 (5%) OR LESS AND WITH A CROSS SLOPE OF 1:50 (2%) OR LESS OR A RAMP WITH A RUNNING SLOPE OF 1:12 (8.33%) AND A CROSS SLOPE OF 1:50 (2%) WITH APPROPRIATE REQUIREMENTS AS DETAILED WITHIN THIS SET OF DOCUMENTS.
  - IS FREE OF OVERHEAD OBSTRUCTIONS WITHIN 80" ABOVE THE WALKING SURFACE
  - IS FREE OF OBJECTS WHICH PROTRUDE MORE THAN 4" BETWEEN THE HEIGHTS OF 27" AND 80" ABOVE THE WALKING SURFACE

**LEGEND**

- INDICATES EXISTING BUILDING TO REMAIN (NO WORK)
- INDICATES NEW PORTABLE BUILDING UNDER THIS APPLICATION
- INDICATES EXISTING FIRE TRUCK ACCESS OVER AC PAVING
- HALF-TONE DASHED LINE INDICATES EXISTING ACCESSIBLE PATH OF TRAVEL
- INDICATES PROPOSED ACCESSIBLE PATH OF TRAVEL, THIS APPLICATION

Ownership of Documents  
 This document, the ideas and designs incorporated herein, as an instrument of Professional Service is the property of Integrated Designs by SOMAM Inc. and is not to be used, in whole or in part for any other project without written authorization.  
 © COPYRIGHT 2014

**integrated designs** by SOMAM, Inc.  
 ARCHITECTURE • INTERIOR DESIGN • CONSTRUCTION MANAGEMENT  
 8011 N. Fresno, Suite 130 - Fresno, California 93710  
 Phone (569) 438-0881 Fax (569) 438-0887 E-Mail: design@somam.com  
 www.integrateddesigns.com

Revision	Description	Rev. Date

Sheet Title: **SITE PLAN**  
 FIRE MARSHAL APPROVED  
**3 RELOCATABLE CLASSROOMS**  
**FREMONT ELEMENTARY SCHOOL**  
 BAKERSFIELD CITY SCHOOL DISTRICT  
 607 TEXAS ST., BAKERSFIELD, CA 93307

Sheet No.: **A1.01**  
 Date: 05/27/14  
 Designer: J. J. ...  
 Checker: ...  
 P.C.: C/JH

Agency Approval Stamp:

IDENTIFICATION STAMP  
 DIV. OF THE STATE ARCHITECT  
 APPROVED 116890  
 J. J. ...  
 DATE 7/21/14

Stamp(s):

Job No.: **5124**

Sheet No.: **A1.01**  
 Release: FMA

Seal: LICENSED ARCHITECT  
 J. J. ...  
 No. C 28866  
 STATE OF CALIFORNIA

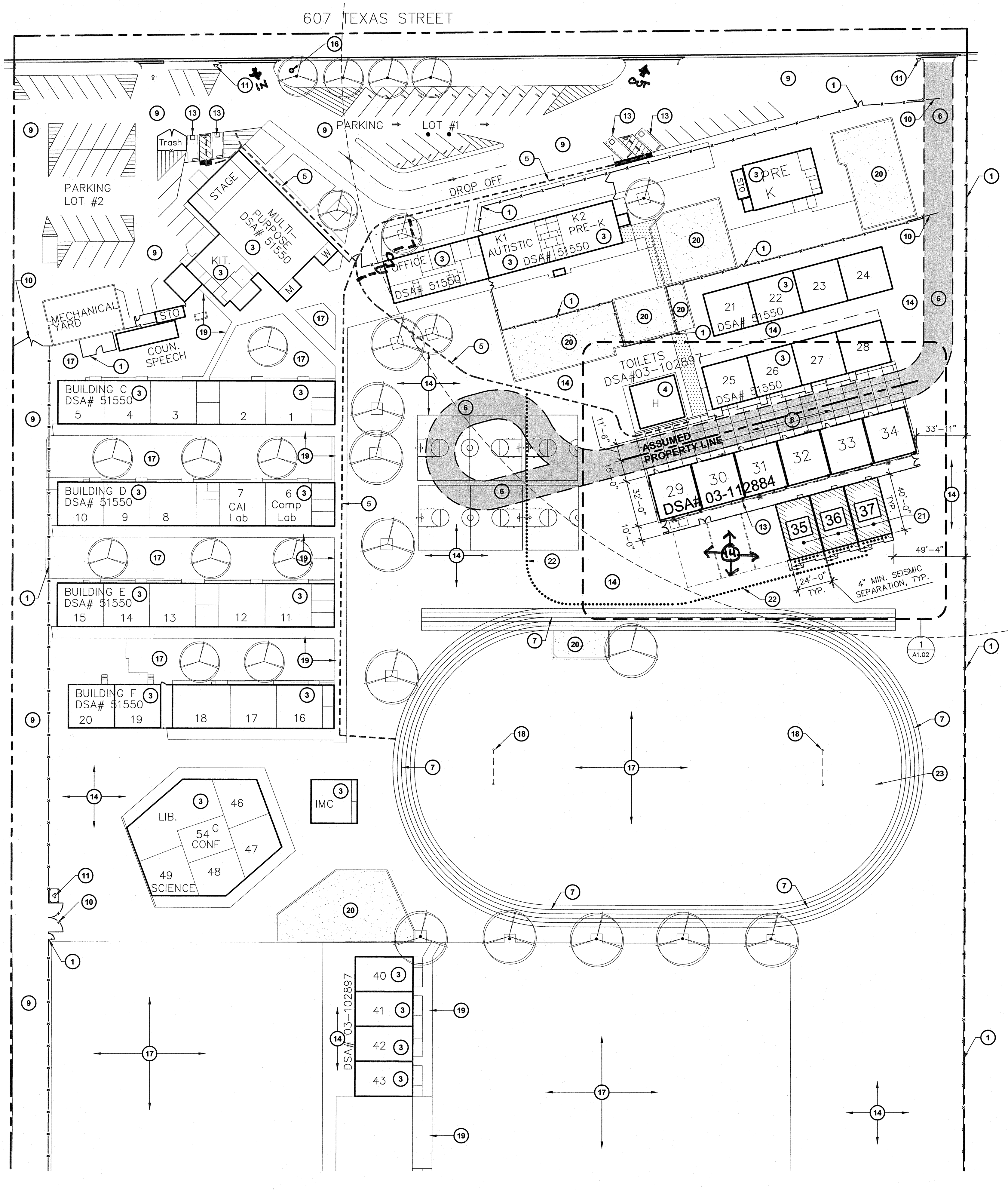
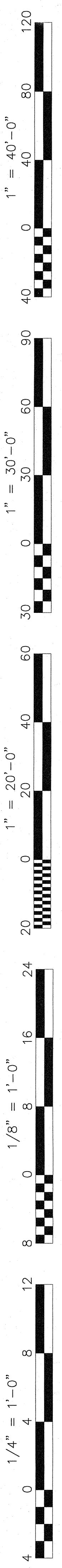

**SITE PLAN**  
**FREMONT ELEMENTARY SCHOOL**

SCALE: 1" = 40'

**GENERAL NOTES**

- A. GENERAL CONTRACTOR SHALL FIELD VERIFY ALL SITE CONDITIONS PRIOR TO BID. IF ANY DISCREPANCIES ARE FOUND, THE ARCHITECT SHALL BE NOTIFIED IN WRITING.
- B. CONTRACTOR SHALL BE RESPONSIBLE FOR THE CORRECTNESS OF LAYOUTS AND ESTABLISHED LOCATIONS OF BURIED UTILITY LINES. ANY UTILITIES REQUIRING RELOCATION SHALL BE THE RESPONSIBILITY OF THE GENERAL CONTRACTOR CONTACT APPLICABLE GOVERNING AGENCIES REGARDING ARRANGEMENT AND COORDINATION OF WORK.
- C. GENERAL CONTRACTOR WILL BE RESPONSIBLE FOR ANY COMPACTION RETEST DUE TO INITIAL FAILURE.
- D. PROJECT INSPECTOR SHALL BE EMPLOYED BY THE OWNER, APPROVED BY THE RESPONSIBLE ARCHITECT AND DSA.
- E. A COPY OF TITLE-24, ALL PARTS APPLICABLE, TO BE KEPT AT THE JOB SITE AT ALL TIMES.
- F. ADDENDA SHALL BE SIGNED BY THE ARCHITECT (RESPONSIBLE IN CHARGE) AND APPROVED BY DSA.
- G. C.C.D.s SHALL BE SIGNED BY THE ARCHITECT (RESPONSIBLE IN CHARGE), OWNER AND APPROVED BY DSA.
- H. TESTING LAB SHALL BE EMPLOYED BY THE OWNER, APPROVED BY THE RESPONSIBLE ARCHITECT AND DSA.
- I. ALL WORK SURFACES DISTURBED OR DAMAGED BY THE CONSTRUCTION ACTIVITIES SHALL BE REPAIRED IN KIND, TEXTURED AND FINISHED TO MATCH ADJACENT SURFACES.
- J. NEW CONCRETE WALKS SHALL HAVE SLOPES NOT TO EXCEED 1 IN 20 IN THE DIRECTION OF PATH OF TRAVEL. PROVIDE CONTROL JOINTS ("C.J.") AT 5'-0" o.c. MAX. AND EXPANSION JOINTS NOT TO EXCEED 30'-0" MAX. PROVIDE MEDIUM BROOM FINISH ON ALL WALKS.
- K. ALL BUILDING AND ROOM NAMES INDICATED ON THESE CONSTRUCTION DOCUMENTS ARE "NOT" THE ACTUAL BUILDING/ ROOM SIGNAGE DESIGNATION. THE GENERAL CONTRACTOR SHALL FURNISH, INSTALL AND COORDINATE ALL REQUIRED SIGNAGE WITH THE OWNER/ARCHITECT PRIOR TO STARTING CONSTRUCTION.
- L. GENERAL CONTRACTOR WILL BE RESPONSIBLE TO COORDINATE RELOCATABLE BUILDING DELIVERY DATES TO THE SCHOOL SITE WITH THE MFG.
- M. THE GENERAL CONTRACTOR SHALL CONSTRUCT ALL NEW RELOCATABLE BUILDING FOUNDATIONS AS PER THE RELOCATABLE BUILDING MANUFACTURER'S DRAWINGS AND SPECIFICATIONS.
- N. THE GENERAL CONTRACTOR SHALL BE RESPONSIBLE TO PROVIDE ALL HOOK-UPS TO THE RELOCATABLE BUILDINGS AFTER INSTALLATION HAS BEEN COMPLETED BY THE MANUFACTURER.
- O. 5'-0" DEEP x 5'-0" WIDE MINIMUM LANDINGS AT DOORWAYS SHALL BE AS DETAILED AND SHALL HAVE SLOPES (IN ANY DIRECTION) OF NOT GREATER THAN 1/4 IN 12 SLOPE. SLOPES SHALL BE AWAY FROM DOORWAYS.
- P. GENERAL/SITE CONTRACTOR SHALL FIELD VERIFY THAT EXISTING PATH OF TRAVEL (P.O.T.) IS A MINIMUM OF 4'-0" WIDE AND IS SLIP RESISTANT. IF IT IS NOT, THEN THE CONTRACTOR SHALL NOTIFY THE ARCHITECT OF RECORD AND A REMEDY OR ALTERNATE P.O.T. WILL BE PROVIDED.
- Q. THE MAXIMUM DROP BETWEEN EXISTING FINISHED GRADES AND THE TOP OF THE P.O.T. SHOULD NOT EXCEED 4". IF IT DOES, PROVIDE THE NECESSARY WARNING CURB PER CBC SEC. 11B-303.5.

**KEYNOTES**

1. EXISTING CHAIN LINK FENCE AND GATE TO REMAIN
2. EXISTING ACCESSIBLE PARKING SIGNAGE, DSA# 03-102897, MOUNTED TO EXISTING C.L. FENCE
3. EXISTING BUILDING TO REMAIN, NO WORK
4. EXISTING ACCESSIBLE RESTROOM BUILDING PER DSA# 03-102897, NO WORK
5. EXISTING ACCESSIBLE PATH OF TRAVEL TO REMAIN, VERIFY IN FIELD
6. EXISTING 20' WIDE FIRE TRUCK ACCESS LANE OVER EXISTING PAVING, APPROVED BY THE LOCAL JURISDICTION.
7. EXISTING TRACK STRIPING TO REMAIN
8. EXISTING CONCRETE WALK WITH MEDIUM BROOM FINISH
9. EXISTING A.C. PAVED PARKING LOT TO REMAIN
10. EXISTING 20' WIDE CHAIN LINK FIRE TRUCK ACCESS GATE. PROVIDE NEW KNOX PAD LOCK PER KERN COUNTY STANDARDS
11. EXISTING FIRE HYDRANT TO REMAIN
12. EXISTING PAIR OF 48" ACCESSIBLE GATES TO REMAIN LOCKED IN THE OPEN POSITION DURING SCHOOL HOURS
13. EXISTING ACCESSIBLE PARKING STALL PER DSA APPL. #03-112884
14. EXISTING A.C. PAVING TO REMAIN
15. PROVIDE 2" WIDE WHITE STRIPING WHERE REQUIRED TO MATCH WITH EXISTING TRACK CONFIGURATION WITHIN THE AREA OF THE NEW AC-PAVING
16. EXISTING TOW-AWAY SIGN MOUNTED TO EXISTING POLE PER DSA APPL. #03-112884
17. EXISTING TURF TO REMAIN, NO WORK
18. EXISTING GOAL POST TO REMAIN
19. EXISTING CONCRETE WALK TO REMAIN
20. EXISTING SAND BOX PLAY AREA TO REMAIN
21. NEW MODULAR CLASSROOM ON WOOD FOUNDATION w/ METAL RAMPS INSTALLED PER MANUFACTURER'S DRAWINGS
22. PROPOSED ACCESSIBLE PATH OF TRAVEL (P.O.T.) REFER TO ACCESSIBILITY NOTE, THIS SHEET

**PARKING CALCULATION**

PARKING LOT #1	
TOTAL STALLS PROVIDED:	27
ACCESSIBLE STALLS REQUIRED PER CBC TABLE 11B-208.2:	2
VAN SPACES REQUIRED (1 PER 6 ADA):	1
ACCESSIBLE STALLS PROVIDED:	1 REGULAR 1 VAN 2 TOTAL
PARKING LOT #2	
TOTAL STALLS PROVIDED:	37
ACCESSIBLE STALLS REQUIRED PER CBC TABLE 11B-208.2:	2
VAN SPACES REQUIRED (1 PER 6 ADA):	1
ACCESSIBLE STALLS PROVIDED:	1 REGULAR 1 VAN 2 TOTAL

**ACCESSIBILITY NOTES**

- ARCHITECT HAS INSPECTED THE PATH OF TRAVEL (P.O.T.) AS INDICATED ON THE PLANS AND HAS FOUND IT TO BE, OR HAS INDICATED ON THE PLANS REMEDIAL WORK WHICH WOULD CAUSE IT TO BE, A BARRIER-FREE ACCESSIBLE ROUTE:
- AT LEAST 48" IN WIDTH; OR AS APPROVED BY CODE
  - FREE OF ABRUPT LEVEL CHANGES EXCEEDING 1/4" IF BEVELED AT 1:2 MAX SLOPE, OR VERTICAL LEVEL CHANGES EXCEEDING 1/4"
  - WITH A FIRM, STABLE, AND SLIP RESISTANT WALKING SURFACE
  - WITH A RUNNING SLOPE OF 1:20 (5%) OR LESS AND WITH A CROSS SLOPE OF 1:50 (2%) OR LESS OR A RAMP WITH A RUNNING SLOPE OF 1:12 (8.33%) AND A CROSS SLOPE OF 1:50 (2%) WITH APPROPRIATE REQUIREMENTS AS DETAILED WITHIN THIS SET OF DOCUMENTS.
  - IS FREE OF OVERHEAD OBSTRUCTIONS WITHIN 80" ABOVE THE WALKING SURFACE
  - IS FREE OF OBJECTS WHICH PROTRUDE MORE THAN 4" BETWEEN THE HEIGHTS OF 27" AND 80" ABOVE THE WALKING SURFACE

**LEGEND**

- INDICATES EXISTING BUILDING TO REMAIN (NO WORK)
- INDICATES NEW PORTABLE BUILDING UNDER THIS APPLICATION
- INDICATES EXISTING FIRE TRUCK ACCESS OVER AC PAVING
- HALF-TONE DASHED LINE INDICATES EXISTING ACCESSIBLE PATH OF TRAVEL
- DOTTED LINE INDICATES PROPOSED ACCESSIBLE PATH OF TRAVEL, THIS APPLICATION

Ownership of Documents  
 This document, the ideas and designs incorporated herein, as an instrument of Professional Service is the property of Integrated Designs by SOMAM Inc. and is not to be used, in whole or in part for any other project without written authorization.  
 © COPYRIGHT 2014

**integrated designs** by SOMAM, Inc.  
 ARCHITECTURE • INTERIOR DESIGN • CONSTRUCTION MANAGEMENT  
 8011 N. Fresno, Suite 130 - Fresno, California 93710  
 Phone (559) 438-0881 Fax (559) 438-0887 E-Mail: design@somam.com  
 www.integrateddesigns.com

Rev.:	Date:
Rev.:	Date:
Rev.:	Date:

**SITE PLAN**

**3 RELOCATABLE CLASSROOMS**  
**FREMONT ELEMENTARY SCHOOL**  
 BAKERSFIELD CITY SCHOOL DISTRICT  
 607 TEXAS ST., BAKERSFIELD, CA 93307

Issue Date: 05/27/14  
 Date: 06/18/14  
 Designer: [Signature]  
 DR: [Signature]  
 PC: C-JH

Agency Approval Stamp:

IDENTIFICATION STAMP  
 DIV OF THE STATE ARCHITECT  
 APPROVED 715590  
 AC: [Signature] FL: [Signature] SS: [Signature] TB: [Signature]  
 DATE: 7/29/14

Stamp(s):

Job No.: **5124**

Sheet No.: **A1.01**

Release: -

CHRISTIAN J. HILL

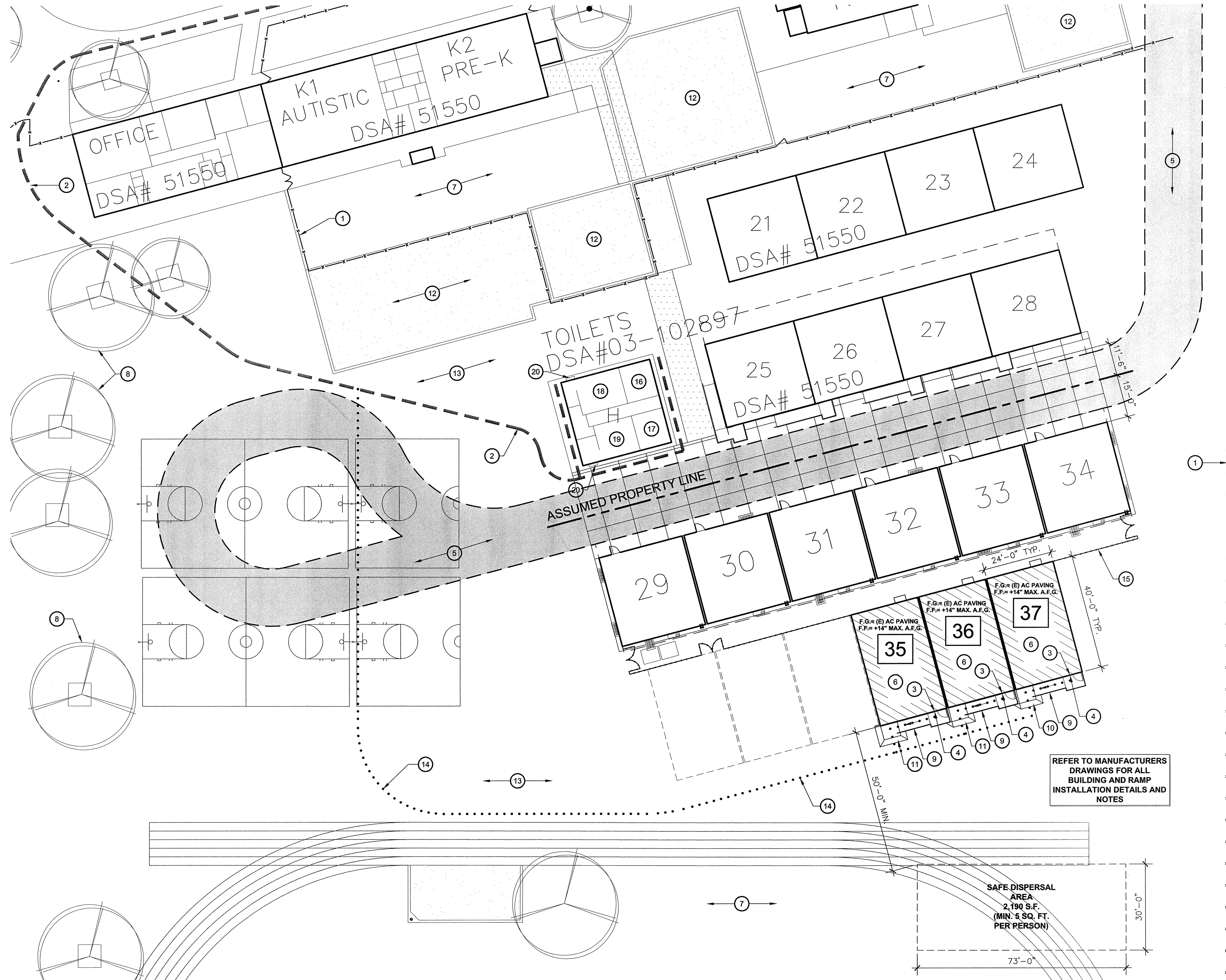
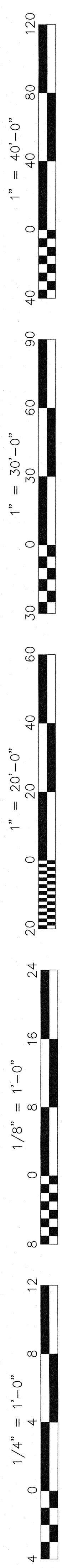

**ENLARGED SITE PLAN  
FREMONT ELEMENTARY SCHOOL**

SCALE: 1" = 20'

**KEY NOTES**

1. EXISTING CHAIN LINK FENCE AND GATE TO REMAIN
2. EXISTING ACCESSIBLE PATH OF TRAVEL, VERIFY IN FIELD FOR COMPLIANCE
3. NEW TACTILE EXIT SIGN PER DETAIL 2/A1.03
4. NEW ROOM IDENTIFICATION AND ISA SIGNAGE, REFER TO DETAILS 3, 4/A1.03
5. EXISTING 20' WIDE FIRE TRUCK ACCESS LANE OVER EXISTING AC PAVING, APPROVED BY THE LOCAL JURISDICTION.
6. NEW TEMPORARY PORTABLE BUILDINGS ON RAISED WOOD FOUNDATIONS WITH METAL RAMP SUPPLIED BY MANUFACTURER, OWNER TO REMOVE ALL INTERFERING PLAY EQUIPMENT
7. EXISTING LANDSCAPE AREA TO REMAIN, NO WORK
8. EXISTING TREE AND PLANTER TO REMAIN
9. METAL RAMP PER 2/R1.0 OR 2/R1.00
10. RAMP TRANSITION PER 18/R1.02
11. RAMP TRANSITION PER 19/R2.0
12. EXISTING SAND BOX PLAY AREA TO REMAIN, NO WORK
13. EXISTING A.C. PAVING TO REMAIN, NO WORK
14. PROPOSED ACCESSIBLE PATH OF TRAVEL PER THIS APPLICATION. SEE ACCESSIBILITY NOTES, SHEET A1.01
15. EXISTING CHAIN LINK MECHANICAL ENCLOSURE TO REMAIN. REMOVE PORTION OF FENCING AT NEW PORTABLE LOCATIONS
16. EXISTING MENS RESTROOM PER DSA APPL. NO. 03-102897
17. EXISTING WOMENS RESTROOM PER DSA APPL. NO. 03-102897
18. EXISTING BOYS RESTROOM PER DSA APPL. NO. 03-102897
19. EXISTING GIRLS RESTROOM PER DSA APPL. NO. 03-102897
20. EXISTING ACCESSIBLE DRINKING FOUNTAIN PER DSA APPL. NO. 03-102897

**GENERAL NOTES**

A. DETERIORATION OR EXISTING NON-COMPLIANT CONSTRUCTION:  
IF ANY CONDITION IS DISCOVERED WHICH, IF LEFT UNCORRECTED, WOULD MAKE THE BUILDING NON-COMPLIANT WITH THE REQUIREMENTS OF THE EDITION OF THE CBC IN FORCE AT THE TIME OF ORIGINAL CONSTRUCTION, THE CONDITION MUST BE CORRECTED IN ACCORDANCE WITH CURRENT CODE REQUIREMENTS. A C.C.D. OR A SEPARATE SET OF PLANS AND SPECIFICATIONS DETAILING AND SPECIFYING THE REQUIRED REPAIR WORK SHALL BE SUBMITTED TO AND APPROVED BY DSA BEFORE PROCEEDING WITH THE REPAIR WORK.  
\*PER DSA IR 16-1, SEC. 5.4

B. CONTRACTOR SHALL ADJUST ALL DOOR CLOSERS TO A MAXIMUM OPENING FORCE OF 5 LBF

**SERIAL NUMBER SCHEDULE**

CLS#	STKP #	SERIAL #
35	66341 (109)	23133 / 23134
36	66341 (109)	29914 / 29915
37	04-101984 (111)	44997 / 44998

**SAFE DISPERSAL**

**TEMP CLASSROOMS**  
 6 (E) CLASSROOMS @ 960 S.F. (30'x32') EA. = 5,760 S.F.  
 3 (N) CLASSROOMS @ 960 S.F. (24'x40') EA. = 2,880 S.F.  
 TOTAL = 8,640 S.F.

8,640 S.F. / 20 S.F. PER OCCUPANT = 432 OCCUPANTS  
 432 OCCUPANTS x 5 S.F. / OCCUPANT = 2,160 S.F. REQ'D  
 2,190 S.F. PROVIDED = OK

**LEGEND**

- INDICATES EXISTING BUILDING TO REMAIN (NO WORK)
- INDICATES NEW TEMPORARY RELOCATABLE BUILDING
- HALF-TONE DASHED LINE INDICATES EXISTING ACCESSIBLE PATH OF TRAVEL
- INDICATES NEW ACCESSIBLE PATH OF TRAVEL PER THIS APPLICATION

**Ownership of Documents**  
This document, the ideas and designs incorporated herein, as an instrument of Professional Service is the property of Integrated Designs by SOMAM, Inc. and is not to be used, in whole or in part for any other project without written authorization.  
© COPYRIGHT 2014

**integrated designs** by SOMAM, Inc.  
ARCHITECTURE · INTERIOR DESIGN · CONSTRUCTION MANAGEMENT  
8011 N. Fresno, Suite 130 - Fresno, California 93710  
Phone (559) 439-0881 Fax (559) 439-0887 E-Mail: design@somam.com  
www.integrateddesigns.com

Revision	Description	Rev. Date

**ENLARGED SITE PLAN**

**3 RELOCATABLE CLASSROOMS  
FREMONT ELEMENTARY SCHOOL**

BAKERSFIELD CITY SCHOOL DISTRICT  
607 TEXAS ST. BAKERSFIELD, CA 93307

Sheet Title: ENLARGED SITE PLAN  
Issue Date: 05/27/14  
Date: 06/19/14  
Designer: [Signature]  
DR: [Signature]  
PC: C/JH

IDENTIFICATION STAMP  
DIV. OF THE STATE ARCHITECT  
APPROVED 115090  
AC [Signature] FILED [Signature] DB  
DATE 7/24/14

Stamp(s):

LICENSED ARCHITECT  
COURTIS E. FLEWELL  
No. C 28266  
STATE OF CALIFORNIA

Job No.: **5124**

Sheet No.: **A1.02**

Release: -

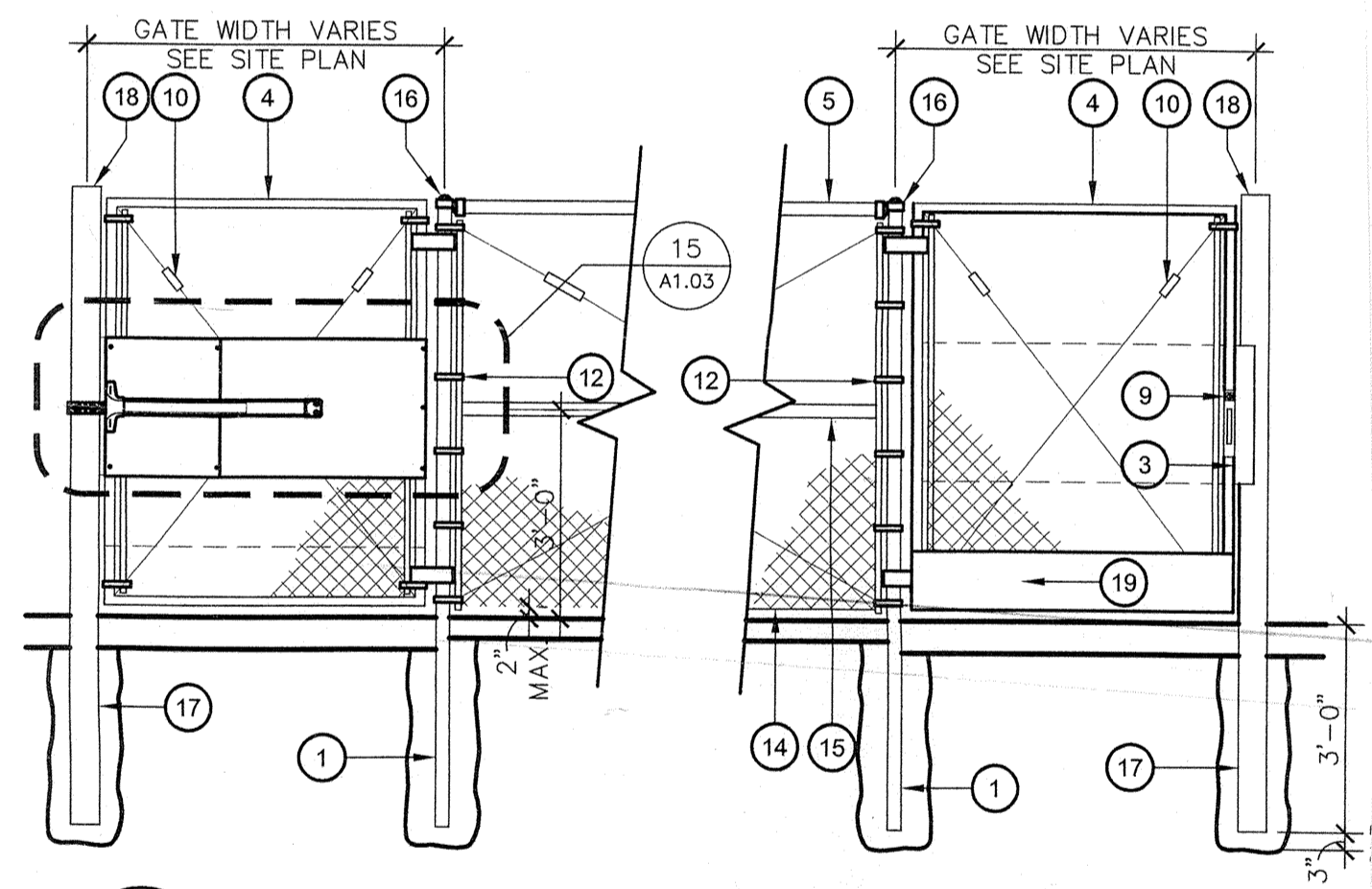
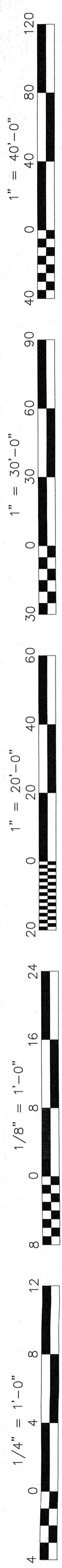

**16 ACCESSIBLE ENTRY GATE AND TYPICAL 6' FENCE**  
 A1.03 ADY100-06 SCALE: N.T.S.

- FENCE ITEMS TO BE FURNISHED & INSTALLED**
- 4" O.D. GALVANIZED STEEL GATE POST (9.1 lb/ft)
  - 180° HINGE (TYP. FOR 4)
  - 16ga GATE GUARD, SEE 15/A1.03
  - 2" O.D. GALVANIZED STEEL GATE FRAME (2.72 lb/ft) (2"x2" TUBE AT SINGLE ENTRY MAN-GATES)
  - 1 5/8" O.D. GALVANIZED STEEL HORIZONTAL RAIL (2.27 lb/ft)
  - 2"x2" MESH x 9 GAUGE GALVANIZED FENCE FABRIC WITH KNUCKLED TOP AND BOTTOM SELVAGE. FENCE FABRIC TO BE GALVANIZED BEFORE WEAVING (GBW)
  - 1/4"x3/4" GALVANIZED STEEL STRETCHER BAR
  - 9 GAUGE (0.148" DIA.) GALVANIZED STEEL-TIE WIRES OR HOG RINGS AT 15" MAX. SPACING. MIN. 8 TIE WIRES PER EACH 10" HORIZONTAL RAIL
  - TRIM, TUBULAR HANDLE & RIM CYLINDER LOCK PER DISTRICT STANDARD
  - GALVANIZED ADJUSTABLE TURNBUCKLE FOR 3/8" DIA. TRUSS ROD
  - 3/8" DIA. GALVANIZED STEEL ADJUSTABLE TRUSS ROD. TRUSS RODS REQUIRED FOR ALL GATE POST PANELS AND END OR CORNER POST PANELS
  - GALVANIZED STEEL STRETCHER BAR TENSION BAND AT 12" MAX. SPACING. MIN. OF 12 TENSION BANDS FOR 12'-0" POST; MIN. OF 6 TENSION BANDS FOR 6'-0" POSTS
  - 3/8"x6" GALVANIZED HOOK BOLT WITH NUT IMBEDDED IN MOWSTRIP MIDWAY BETWEEN POSTS
  - 7 GAUGE (0.177" DIA.) GALVANIZED STEEL TENSION WIRE
  - 1 5/8" O.D. GALVANIZED STEEL HORIZONTAL RAIL TO BE ADDED TO 6'-0" HIGH CHAIN LINK FENCE AROUND KINDERGARTEN PLAY AREA ONLY AND AT END OF BASKETBALL COURTS
  - RAINPROOF CAP
  - 4"x4"x3/16" H.S.S.
  - 3/16" CAP R W/ 3/16" FILLET WELD, GRIND SMOOTH
  - POWDER COATED FINISH OVER ELECTRO-GALVANIZED 10"x GATE WIDTH, 16ga MTL. PLATE (SILVER). BOTH SIDES OF EACH GATE.
  - 5-1/2" THICK CONCRETE MOWSTRIP AT GATE OPENING
  - CLASS B CONCRETE POST FOOTING (TYP.)

**NOTES:**  
 1. CONTRACTOR TO PROVIDE AND INSTALL GATE HOLD BACK FOR EACH DRIVE GATE. HOLD BACK TO BE INSTALLED IN FENCE MOWSTRIP, UNLESS OTHERWISE SHOWN.

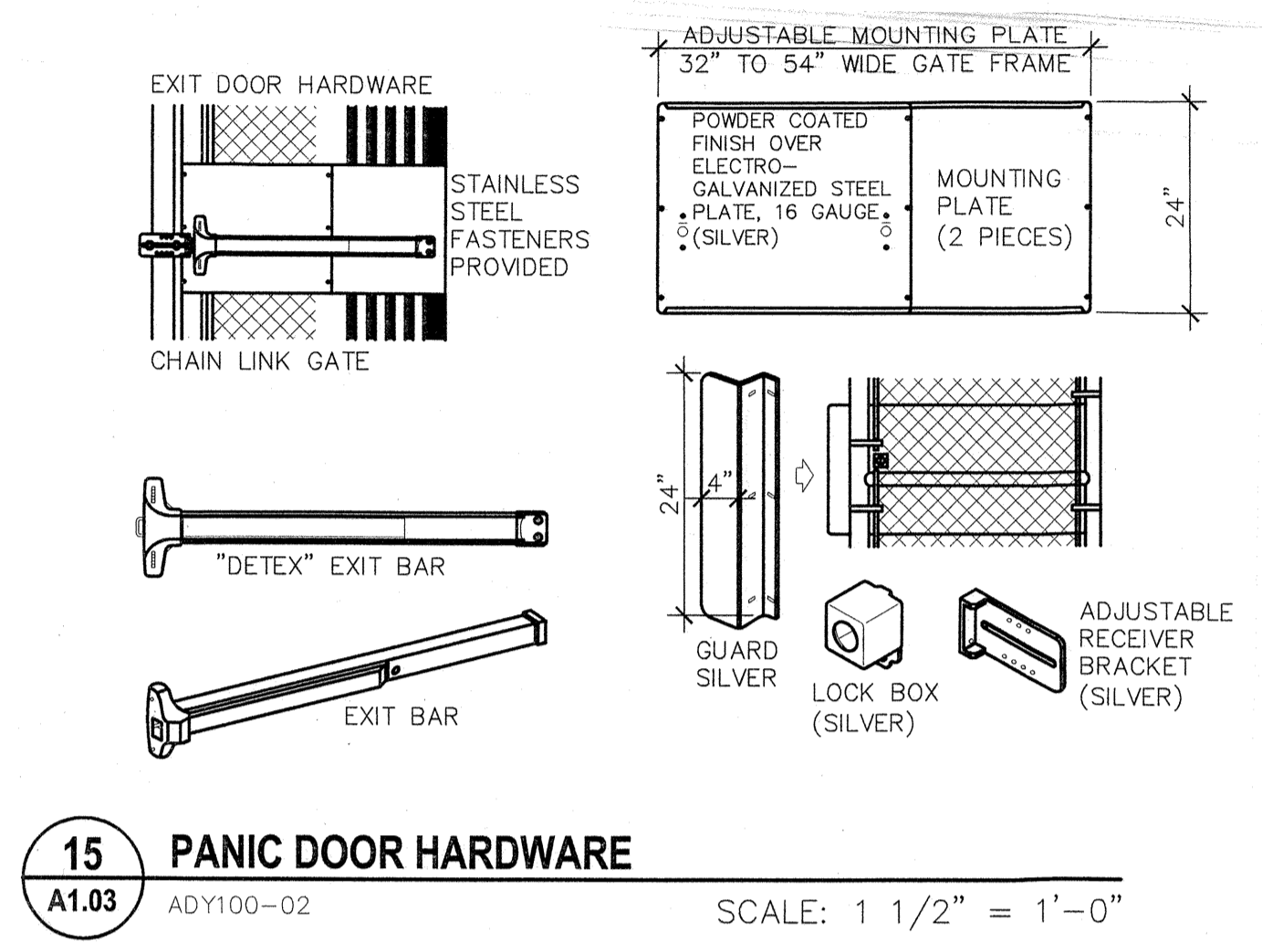

**15 PANIC DOOR HARDWARE**  
 A1.03 ADY100-02 SCALE: 1 1/2" = 1'-0"

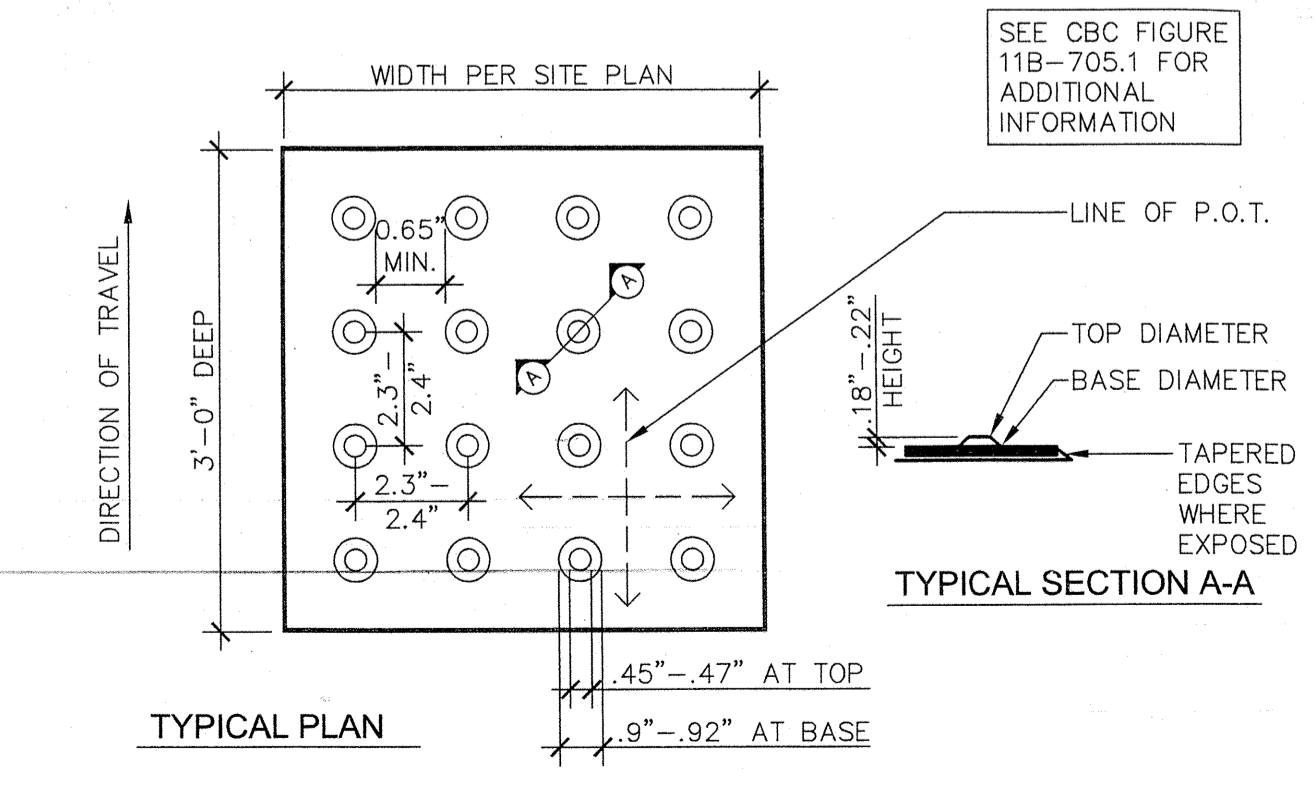

**11 TRUNCATED DOMES**  
 A1.03 ADA100-23 SCALE: NO SCALE

- NOTES:**
- DOOR SIGNS TO BE CONSTRUCTED FROM 1/4" THICK PLASTIC OR HEAT STAMPED FIGURES. COLORS TO BE SELECTED BY ARCHITECT.
  - ATTACH SIGNS USING FOUR (4) FLATHEAD, STAINLESS STEEL, TAMPER PROOF SCREWS, (COUNTERSUNK) AND ADHESIVE.
  - 70% CONTRAST BETWEEN CHARACTERS AND BACKGROUND

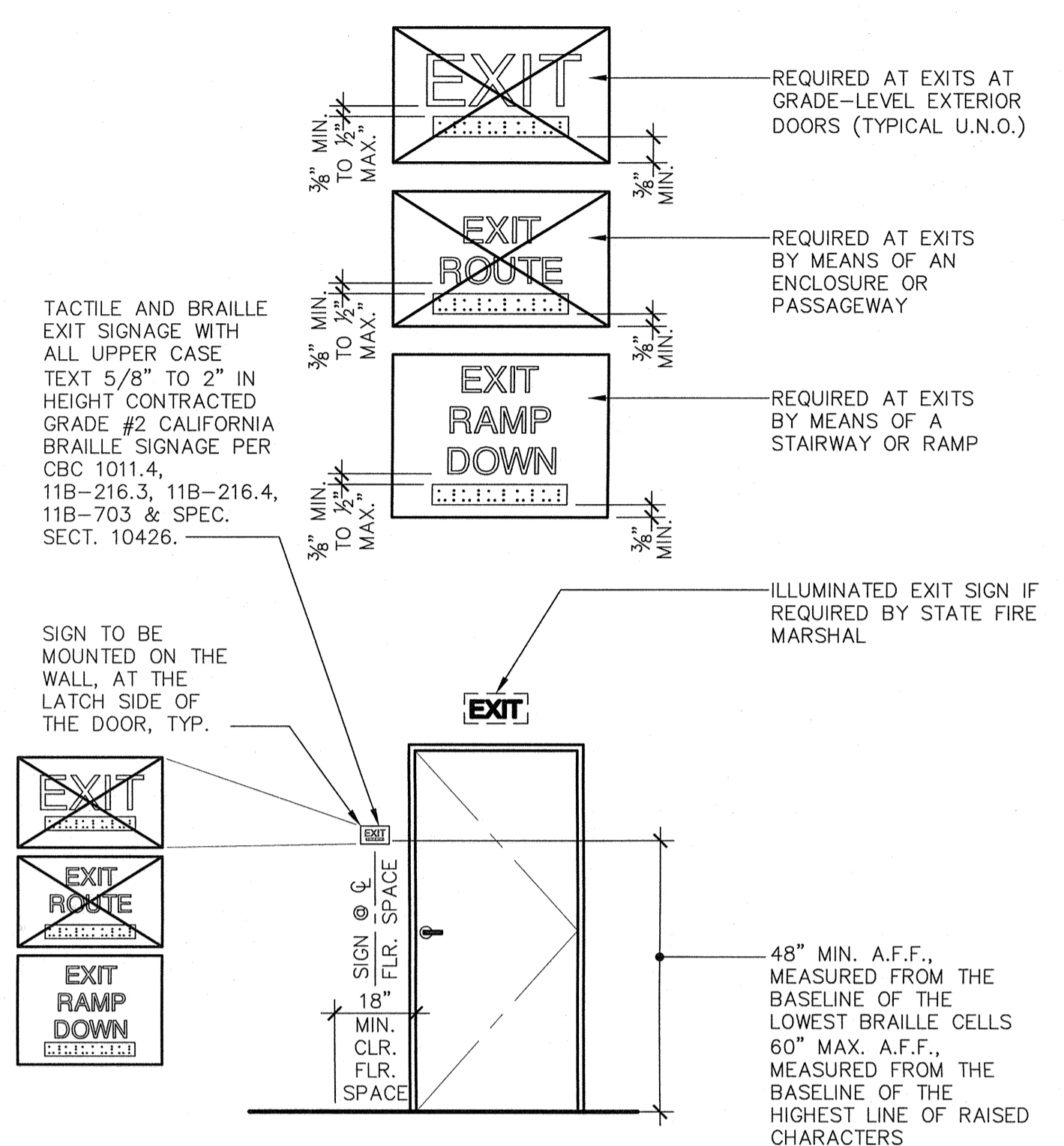

**2 TYPICAL EXTERIOR DOOR SIGNAGE**  
 A1.03 ADX200-01 SCALE: 3/8" = 1'-0"

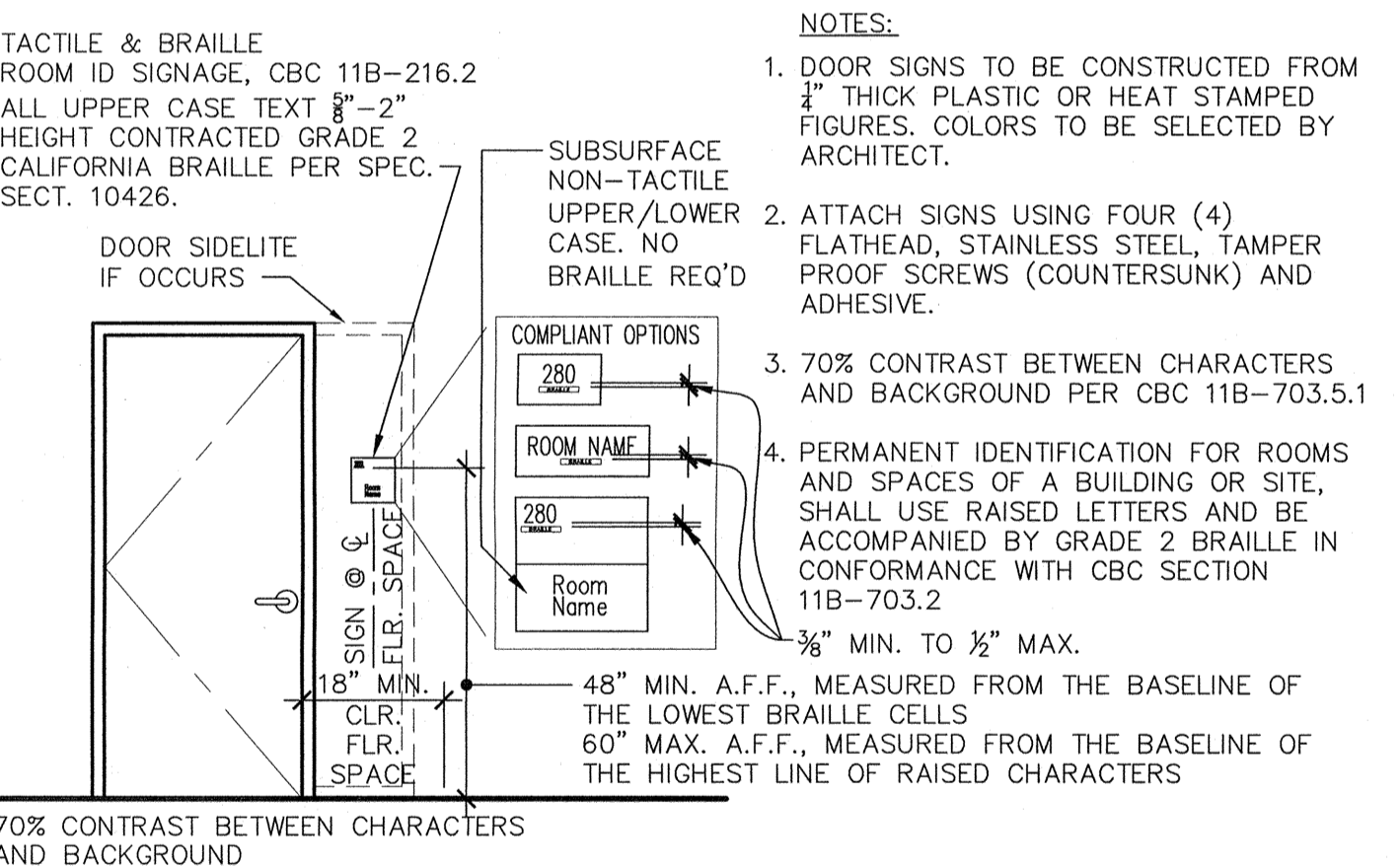

**3 ROOM ID SIGNAGE**  
 A1.03 ADX100-01 SCALE: NO SCALE

- NOTES:**
- DOOR SIGNS TO BE CONSTRUCTED FROM 1/4" THICK PLASTIC OR HEAT STAMPED FIGURES. COLORS TO BE SELECTED BY ARCHITECT.
  - ATTACH SIGNS USING FOUR (4) FLATHEAD, STAINLESS STEEL, TAMPER PROOF SCREWS (COUNTERSUNK) AND ADHESIVE.
  - 70% CONTRAST BETWEEN CHARACTERS AND BACKGROUND PER CBC 11B-703.5.1.
  - ISA SYMBOL CAN ALSO BE PLACED ON DOOR. THE LOCATION IS NOT REGULATED.

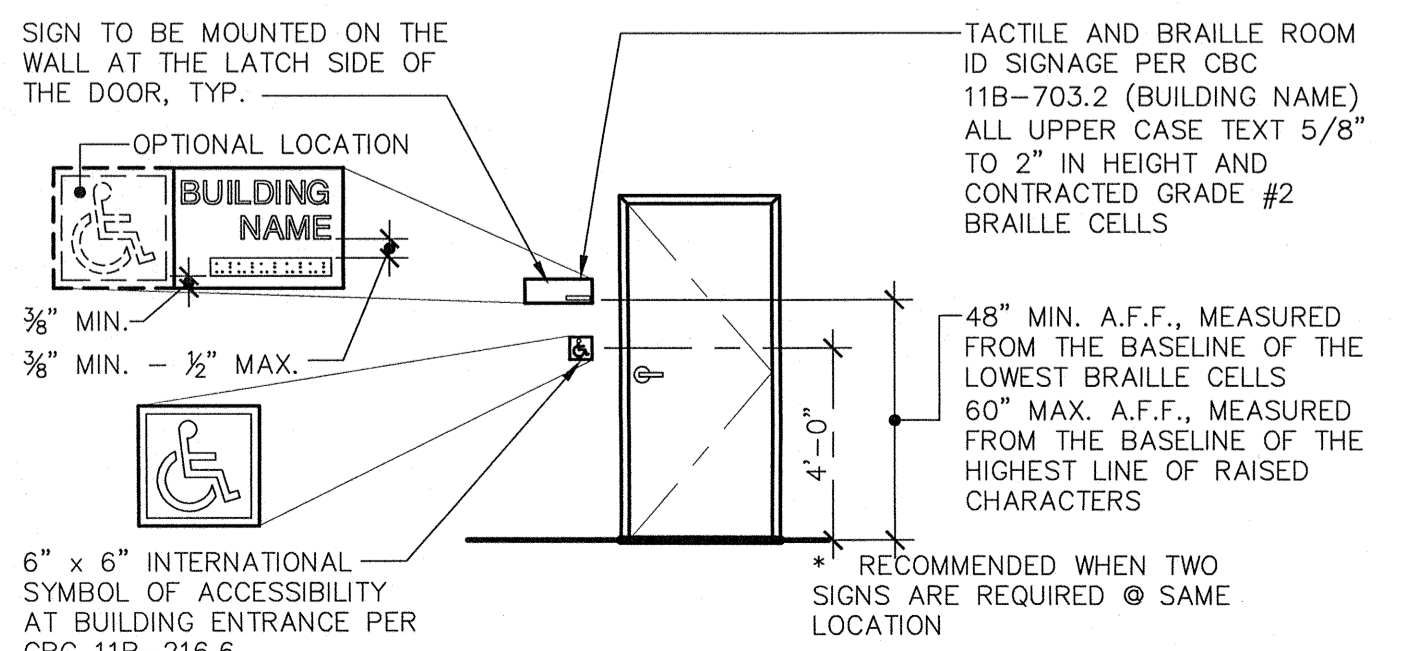

**4 BUILDING ENTRANCE/I.S.A. SIGNAGE**  
 A1.03 ADA100-01 SCALE: 1/4" = 1'-0"

Ownership of Documents  
 This document, the ideas and designs incorporated herein, as an instrument of Professional Service is the property of Integrated Designs by SOMAM, Inc. and is not to be used, in whole or in part for any other project without written authorization.  
 © COPYRIGHT 2014

**integrated designs** by SOMAM, Inc.  
 ARCHITECTURE - INTERIOR DESIGN - CONSTRUCTION MANAGEMENT  
 8011 N. Fresno, Suite 130 - Fresno, California 93710  
 Phone (559) 430-0881 Fax (559) 430-0887 E-Mail: design@somam.com  
 www.integrateddesigns.com

Rev. No.	Date	Description

**SITE DETAILS**

Project Name & Address:  
**3 RELOCATABLE CLASSROOMS**  
**FREMONT ELEMENTARY SCHOOL**  
 BAKERSFIELD CITY SCHOOL DISTRICT  
 607 TEXAS ST., BAKERSFIELD, CA 93307

Issue Date: 05/27/14  
 Date: 06/19/14  
 Designer: [Signature]  
 DR: [Signature]  
 PC: CUH

Agency Approval Stamp:

IDENTIFICATION STAMP  
 DIV OF THE STATE ARCHITECT  
 APPROX 116600  
 AC: [Signature]  
 D: [Signature]

7/24/14

Stamp(s):

Job No: **5124**

Sheet No: **A1.03**

Released: [Signature]

CHRISTIAN J. HILL

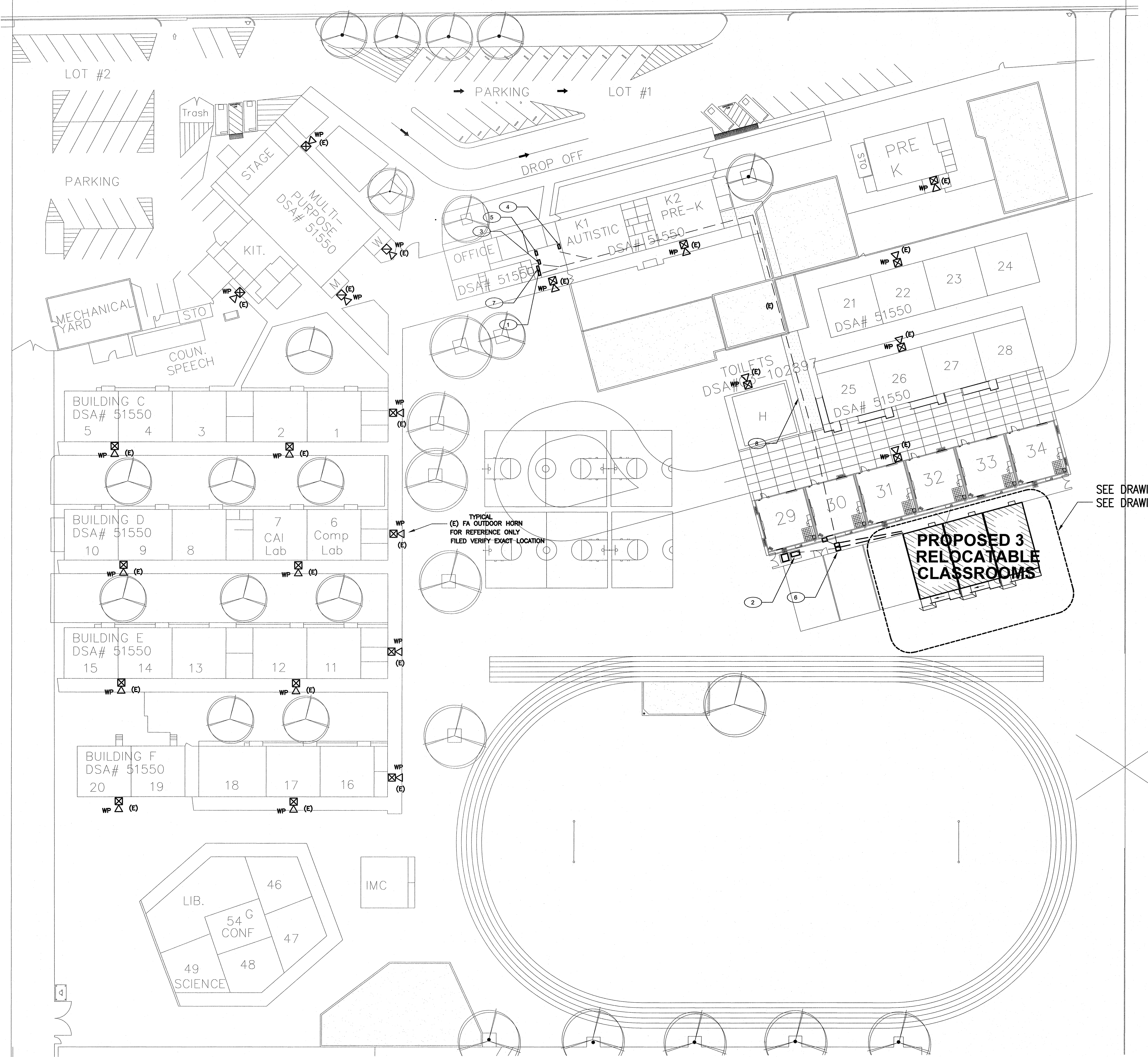
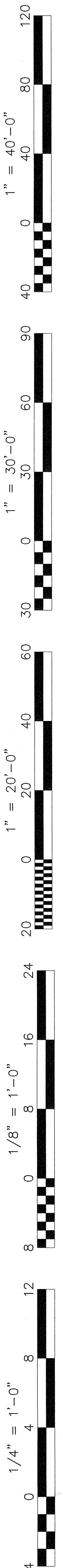

SEE DRAWING E-2 FOR POWER AND SIGNAL  
SEE DRAWING E-3 FOR FIRE ALARM

### SHEET NOTES

- 1 APPROXIMATE LOCATION FOR EXISTING ADDRESSABLE FIRE ALARM CONTROL PANEL TO REMAIN IN SERVICE. PROVIDE CONNECTION TO NEW FIRE ALARM DEVICES PER PLANS. UPDATE NEW FIRE ZONE MAP AND PROGRAM NEW DEVICES INFORMATION. MEASURE ACTUAL LOAD CURRENT AND VOLTAGE DROP FOR EACH INR SIGNAL CIRCUITS, AND FACP STANDBY CURRENT AND ALARM CURRENT. SEND THE REPORT TO OWNER AND ENGINEER FOR REVIEW, AND PLASTIC LAMINATED ONE COPY INSIDE FACP CABINET DOOR.
- 2 APPROXIMATE LOCATION FOR EXISTING DISTRIBUTION PANEL H. PROVIDE NEW BREAKERS, FEEDERS AND POWER CONNECTION FOR NEW RELOCATABLE CLASSROOM BUILDINGS PER PLANS. SEE SINGLE LINE DIAGRAM.
- 3 APPROXIMATE LOCATION FOR EXISTING P/A/C/TELEPHONE EQUIPMENT IN ADMIN OFFICE. PROVIDE NEW CABLE AND CONNECTION FOR NEW SIGNAL DEVICES PER PLANS.
- 4 APPROXIMATE LOCATION FOR EXISTING COMPUTER M/F SERVER EQUIPMENT IN ADMIN OFFICE. PROVIDE NEW CABLE AND CONNECTION FOR NEW SIGNAL DEVICES PER PLANS.
- 5 APPROXIMATE LOCATION FOR EXISTING MASTER INTRUSION ALARM EQUIPMENT IN ADMIN OFFICE. PROVIDE NEW CABLE AND CONNECTION FOR NEW SIGNAL DEVICES PER PLANS.
- 6 (E) SIGNAL AND POWER PULL BOXES. EXTEND NEW I/LG CONDUITS AND WIRING TO NEW BUILDINGS PER PLANS. SEE RISER DIAGRAMS.
- 7 FURNISH AND INSTALL A NEW FIRE ALARM DIGITAL VOICE COMMAND CENTER AND INTER CONNECT TO EXISTING FIRE ALARM CONTROL PANEL. SURFACE MOUNT NEXT TO (E) FACE. FILED VERIFY EXACT LOCATION. SEE FA DRAWING E-3 RISER DIAGRAM.
- 8 APPROXIMATE LOCATION AND ROUTING FOR EXISTING SIGNAL CONDUITS. FILL IN NEW CONDUCTORS PER PLANS. FILED VERIFY LOCATION AND SEE RISER DIAGRAMS.

(E) --- INDICATE EXISTING CONDUIT AND WIRING. FOR REFERENCE ONLY. FIELD VERIFY AS REQUIRED.

### CODE RULES AND REGULATIONS

ALL WORK AND MATERIAL SHALL BE IN FULL ACCORDANCE WITH THE LATEST RULES AND REGULATIONS OF THE STATE FIRE MARSHAL, THE CALIFORNIA ELECTRICAL CODE; THE SAFETY ORDERS OF THE DIVISION OF INDUSTRIAL SAFETY AND OTHER APPLICABLE STATE LAWS OR REGULATIONS. NOTHING IN THESE PLANS OR SPECIFICATIONS IS TO BE CONSTRUED TO PERMIT WORK NOT CONFORMING TO THESE CODES.

**DIVISION OF THE STATE ARCHITECT APPLICABLE CODES AND STANDARDS:**  
 2007 CALIFORNIA ELECTRIC CODE (CEC).  
 2007 CALIFORNIA FIRE CODE (CFC).  
 2007 TITLE 19 (CCR), PUBLIC SAFETY, STATE FIRE MARSHAL  
 2002 NFPA 72 (CALIFORNIA AMENDED) - NATIONAL FIRE ALARM CODES. POLICY #95-03, FIRE AND LIFE SAFETY, DIVISION OF THE STATE ARCHITECT OFFICE OF REGULATION SERVICES.

**REGULATIONS UNDERGROUND SERVICE ALERT**  
CALL BEFORE YOU DIG: 1-800-642-2444

THE LOCATION OF EXISTING UNDERGROUND UTILITIES WERE TAKEN FROM SOURCES BELIEVED TO BE RELIABLE. HOWEVER, THEY HAVE NOT BEEN INDEPENDENTLY VERIFIED BY THE OWNER OR THIS ENGINEER. THE CONTRACTORS SHALL DETERMINE THE EXACT LOCATION OF ALL EXISTING UTILITIES BEFORE COMMENCING WORK, AND AGREE TO BE FULLY RESPONSIBLE FOR ANY AND ALL DAMAGES WHICH MIGHT BE OCCASIONED BY THE CONTRACTOR'S FAILURE TO EXACTLY LOCATE AND PRESERVE ANY AND ALL UNDERGROUND UTILITIES.

NOTIFY OWNER 72 HOURS PRIOR TO ANY EXCAVATION

CONSULTING ENGINEERS  
**JOHN CHONG ENGINEERING**  
 JOHN S. CHONG  
 E 14419  
 Exp. 8/30/2016  
 ELECTRICAL  
 REGISTERED PROFESSIONAL ENGINEER  
 STATE OF CALIFORNIA  
 2017 E. DECATUR AVE. FRESNO CA 93710  
 (559) 215-9266 • FAX 297-9441  
 jchong1neer@aol.com

## SITE PLAN - ELECTRICAL

### 3 RELOCATABLE CLASSROOM

SCALE : 1" = 30' - 0"

Ownership of Documents  
 This document, the ideas and designs incorporated herein, as an instrument of Professional Service is the property of Integrated Designs by SOMAM Inc. and is not to be used, in whole or in part for any other project without written authorization.  
 © COPYRIGHT 2013

**integrated designs** by SOMAM, Inc.  
 ARCHITECTURE - ENGINEERING - INTERIOR DESIGN - CONSTRUCTION MANAGEMENT  
 6011 N. Fresno, Suite 130 - Fresno, California 93710  
 Phone (559) 435-0881 Fax (559) 435-0887 E-Mail: design@somam.com  
 www.integrateddesigns.com

Rev. No.	Rev. Date	Rev. Description

**SITE PLAN - ELECTRICAL**

**FREMONT ELEMENTARY SCHOOL**  
**3 RELOCATABLE CLASSROOMS**  
 BAKERSFIELD CITY SCHOOL DISTRICT  
 607 TEXAS STREET, BAKERSFIELD, CA

Issue Date: 00/00/14  
 Date: 05/28/14  
 Designer: J CHONG  
 DR: J CHONG  
 PC: C.M

Agency Approval Stamp:

FILE # 15-6

IDENTIFICATION STAMP  
 DIV. OF THE STATE ARCHITECT  
 OFFICE OF REGULATION SERVICES

115890  
 AC: JCH FLS 20 SS JB  
 DATE: 7/24/14

TRACKING #: DSA TRACKING NO.

Stamp(s):

NOTED ARCHITECT  
 CURTIS E. FINE  
 No. C 28966  
 Exp. 5-31-15  
 STATE OF CALIFORNIA

Job No.: **5124**

Sheet No.: **E-1**

Release

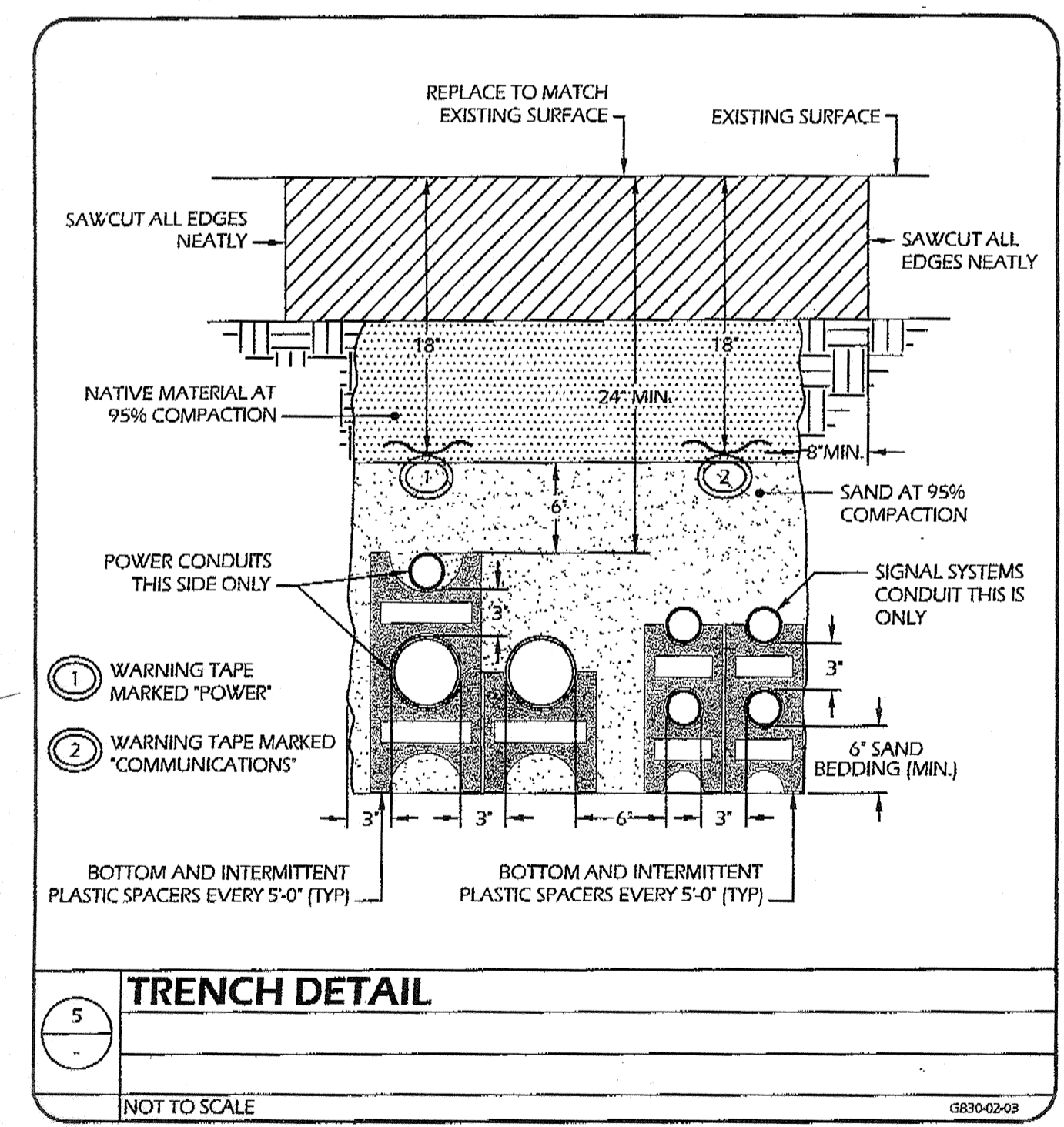
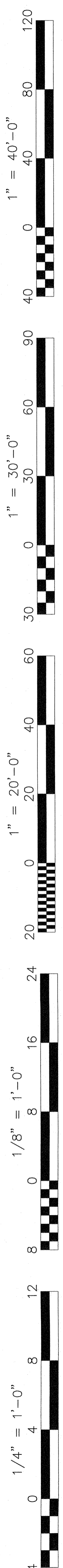

SERVING		120/240V 1Ø 3W		REAR		FLUSH	
NO	NOTE	QTY	AVG	FILE	QTY	FILE	NOTE
1	RECEPTACLE	12/12	20/1	0.7/7.1	60/2	8	10 HVAC 3.5 TON
3	RECEPTACLE	12/12	20/1	0.7/7.1	20/1	12	12 SPACE
5	SPACE	12/12	20/1		20/1	12	12 SPACE
7	SPACE	12/12	20/1		20/1	12	12 SPACE
9	INT/EXT LIGHTS	12/12	20/1	0.8	20/1	12	12 SPACE
11	INT LIGHTS	12/12	20/1	0.8/0.1	20/1	12	12 FIRE ALARM NAC PANEL
		8.7KVA 18.7KVA		72A 72A			

**POWER AND SIGNAL PLAN**  
**3 RELOCATABLE CLASSROOMS**

SCALE : 1/8" = 1' - 0"

**SHEET NOTES**

- APPROXIMATE LOCATION FOR NEW FIRE ALARM DISTRIBUTED POWER MODULE. PROVIDE 110V POWER CONNECTION AND DEDICATED CIRCUIT FROM PANEL A-12. SEE DRAWING E-3 FOR MORE INFORMATION.
- PROVIDE POWER CONNECTION FOR RELOCATABLE BUILDING PRE-WIRED PANEL. SEE SINGLE LINE DIAGRAM ON DRAWING E-4.
- EXISTING 800A PANEL H, PROVIDE NEW CONDUITS AND FEEDERS FOR NEW PRE-WIRED PANEL. POWER CONNECTION. SEE SINGLE LINE DIAGRAM.
- PROVIDE #8 COPPER GROUNDING CONDUCTOR AND BOND TO EACH SECTION STRUCTURAL STEEL BEAM. FIELD VERIFY EXACT LOCATION WITH GENERAL CONTRACTOR PRIOR TO INSTALLATION.
- NEW SECURITY ALARM PANEL AND SYSTEM. PROVIDE 110V POWER CONNECTION AND INTERCONNECTION TO (E) MASTER EQUIPMENT IN ADMIN OFFICE. FIELD VERIFY EXACT LOCATION AND REQUIREMENT WITH OWNER PRIOR TO INSTALLATION. SEE RISER DIAGRAM.
- EXISTING OUTDOOR FEE STAND IDF CABINET. PROVIDE NEW DATA CABLES AND COMPUTER OUTLETS PER PLANS. FIELD VERIFY EXACT LOCATION AND REQUIREMENT WITH OWNER PRIOR TO INSTALLATION. SEE RISER DIAGRAM.
- DATA AND POWER OUTLET AT CEILING FOR SMART BOARD. FIELD VERIFY EXACT LOCATION AND REQUIREMENT WITH OWNER PRIOR TO INSTALLATION. SEE RISER DIAGRAM.
- PROVIDE 50 PAIR PUNCH DOWN BLOCK AND SURFACE MOUNTED BELOW CEILING FOR INTERCOM / TELEPHONE WIRING TERMINATION.
- NEW 24"x24"x4" NEMA3R SIGNAL TO SURFACE MOUNTED ON EXTERIOR WALL. PROVIDE (2) 2" STUB INTO BUILDING ATTIC CAVITY. SEE SIGNAL RISER DIAGRAM.
- SNW OUT AND PATCH EXISTING CONCRETE FLOOR TO INSTALL NEW (2) 2" U.G. CONDUITS FOR SIGNAL AND (1) 3/4" FOR FA. FIELD VERIFY LOCATION WITH OWNER AND GENERAL CONTRACTOR PRIOR TO INSTALLATION. **SEE DETAIL 5/E-2**
- NEW 12"x24" PULL BOX WITH EXTENSION. FIELD VERIFY LOCATION. SEE RISER DIAGRAMS.
- STUB OUT NEW (1) 2" U.G. CONDUITS FOR SIGNAL AND (1) 3/4" FOR FA. FIELD VERIFY LOCATION WITH OWNER AND GENERAL CONTRACTOR PRIOR TO INSTALLATION.
- STUB OUT NEW (1) 1-1/4" U.G. CONDUITS FOR POWER. FIELD VERIFY LOCATION WITH OWNER AND GENERAL CONTRACTOR PRIOR TO INSTALLATION.

**SIGNAL AND COMM. LEGEND**

- SECURITY ALARM SYSTEM**
- DS-C DIGITAL SECURITY ALARM CONTROL PANEL. MODEL SONITROL (64ZONE). INTERFACE WITH EXISTING BUILDING MASTER SECURITY ALARM PANEL AS REQUIRED.
  - K LCO KEYPAD - MATCH EXISTING EQUIPMENT AS REQUIRED.
  - M DUAL TECHNOLOGY CEILING MOUNT DETECTOR. MATCH EXISTING EQUIPMENT AS REQUIRED.
  - B EXTERIOR BELL (SIREN) - DSC6515W WITH WEATHERPROOF BACKBOX AND TAMPER SWITCH.
  - W DOOR CONTACT SWITCH. RECESS ABOVE DOOR JAMB AT OPEN SIDE.
  - B INDOOR SECURITY ALARM CABLE. WEST PENN #4C224
  - B1 OUTDOOR SECURITY ALARM CABLE. WEST PENN #4CQ224
- COMMUNICATION (TELEPHONE/INTERCOM) SYSTEM**
- ▽ HANSEY/P PHONE - FIELD VERIFY MODEL NO. AND MATCH EXISTING MASTER EQUIPMENT AS REQUIRED.
  - SP CEILING SPEAKER - RAULAND #JUS0221 W/ACC1000 BAFFLE. PROVIDE BACKBOX AND CEILING SUPPORT AS REQUIRED.
  - SP OUTDOOR SPEAKER - ATLAS #AFF15 HORN W/FMR AND LOWELL (#3884 FOR SURFACE, #676X FOR RECESS) BACK BOX W/SILK GRILL
  - T OUTDOOR TELE/AC CABLE. 22AWG SOLID COPPER 12 PAIR SHIELDED AND 12 PAIR UNSHIELDED CABLE.
  - T1 INDOOR TELEPHONE CABLE. CAT.3 22AWG SOLID COPPER 4UTP SHIELDED CABLE.
  - P1 OUTDOOR PA/AC CABLE - WEST PENN #4QC-369
- DATA COMMUNICATION SYSTEM**
- [2] DATA OUTLET - LEVITON CAT 5E (DUAL RECEPTACLE RED IN COLOR FOR ADMINISTRATIVE)
  - [2] DATA OUTLET - LEVITON CAT 5E (DUAL RECEPTACLE BLUE IN COLOR FOR INSTRUCTIONAL)
  - FO FIBER OPTIC CABLE VIA INNER DUCT WITH J-HOOK IN ATTIC AND 2" FOR OUTDOOR. SEE RISER DIAGRAM FOR MODEL NO.
  - C1 (ONE) CAT 5E 22AWG 4UTP. SEE RISER DIAGRAM FOR MODEL NO.
  - C2 (TWO) CAT 5E 22AWG 4UTP. SEE RISER DIAGRAM FOR MODEL NO.

**NOTES:**  
 1. ALL SIGNAL CONDUCTORS CANNOT SPLICE INSIDE PULL BOX. CONDUCTOR MUST BE CONTINUE RUN BETWEEN SIGNAL DEVICES BACK BOX OR ABOVE GROUND TERMINAL CABINET.

Ownership of Documents  
 This document, the ideas and designs incorporated herein, as an instrument of Professional Service is the property of Integrated Designs by SOMAM, Inc. and is not to be used, in whole or in part for any other project without written authorization.  
 © COPYRIGHT 2013

**integrated designs by SOMAM, Inc.**  
 ARCHITECTURE · ENGINEERING · INTERIOR DESIGN · CONSTRUCTION MANAGEMENT  
 6011 N. Fremont, Suite 130, Fresno, California 93710  
 Phone (559) 436-0881 Fax (559) 436-0887 E-Mail: design@somam.com  
 www.integrateddesigns.com

**POWER AND SIGNAL PLAN**

**FREMONT ELEMENTARY SCHOOL**  
**3 RELOCATABLE CLASSROOMS**  
 BAKERSFIELD CITY SCHOOL DISTRICT  
 607 TEXAS STREET, BAKERSFIELD, CA

Issue Date: 00/00/14  
 Date: 05/28/14  
 Designer: J. CHONG  
 DR: J. CHONG  
 PC: C.J.M.

Agency Approval Stamp:  
 FILE # 15-6  
 IDENTIFICATION STAMP  
 DIV. OF THE STATE ARCHITECT  
 OFFICE OF REGULATION SERVICES  
 115890  
 AC: W.F.S. CO. SS. JB  
 DATE: 7/24/14  
 TRACKING #: DSA TRACKING NO.

Stamp(s):

CONSULTING ENGINEERS  
**JOHN S. CHONG ENGINEERING**  
 JOHN S. CHONG  
 E 14419  
 Exp. 6/30/2016  
 ELECTRICAL  
 STATE OF CALIFORNIA

Job No.: **5124**

Sheet No.: **E-2**

Release: 7/8/2014 8:25:10 AM





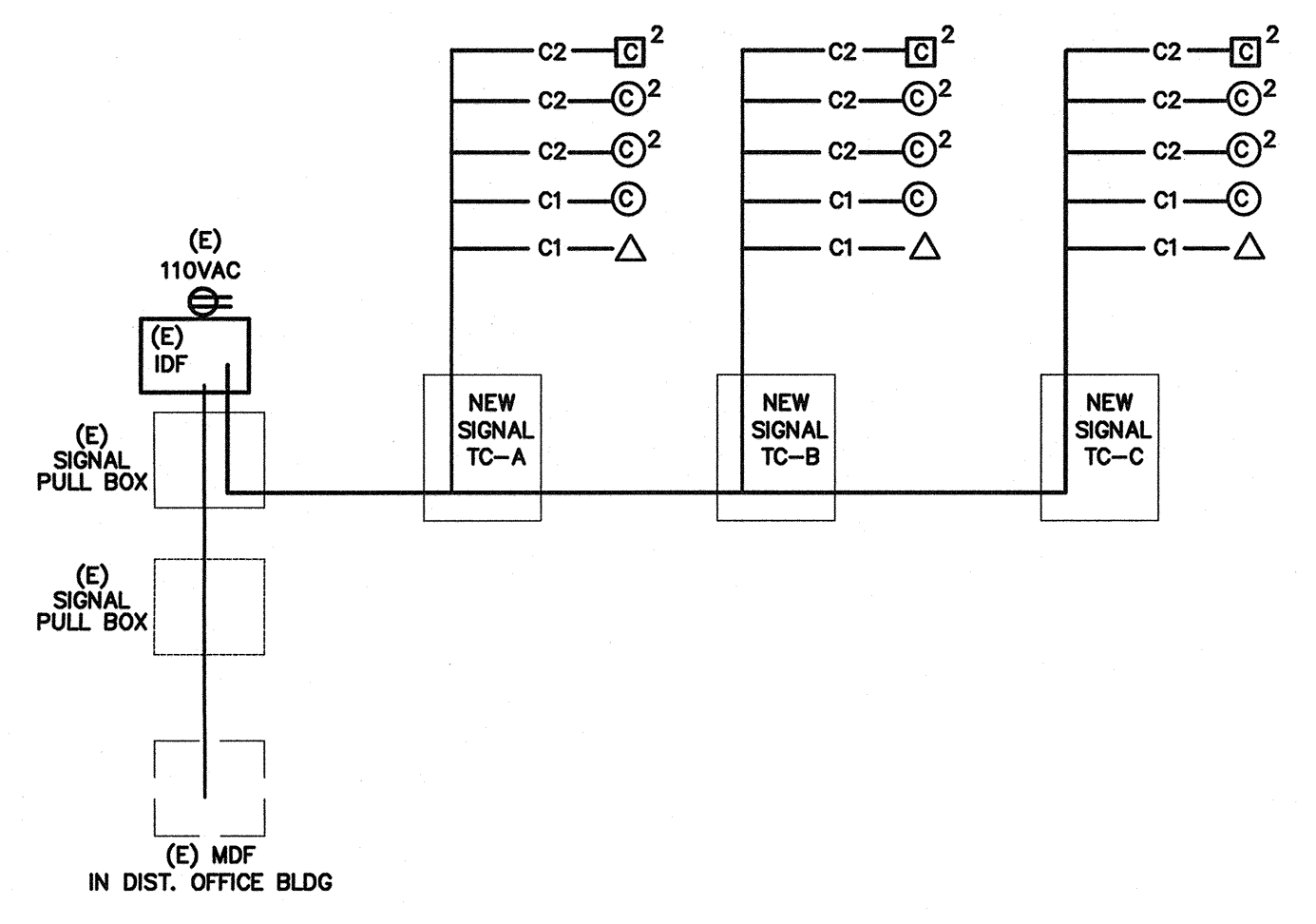
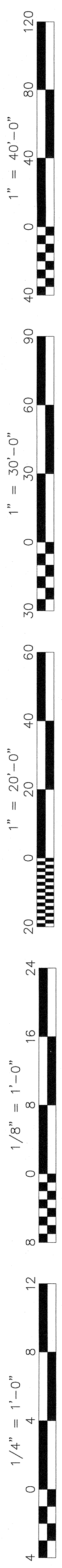

5 SECURITY ALARM SYSTEM RISER DIAGRAM N.T.S

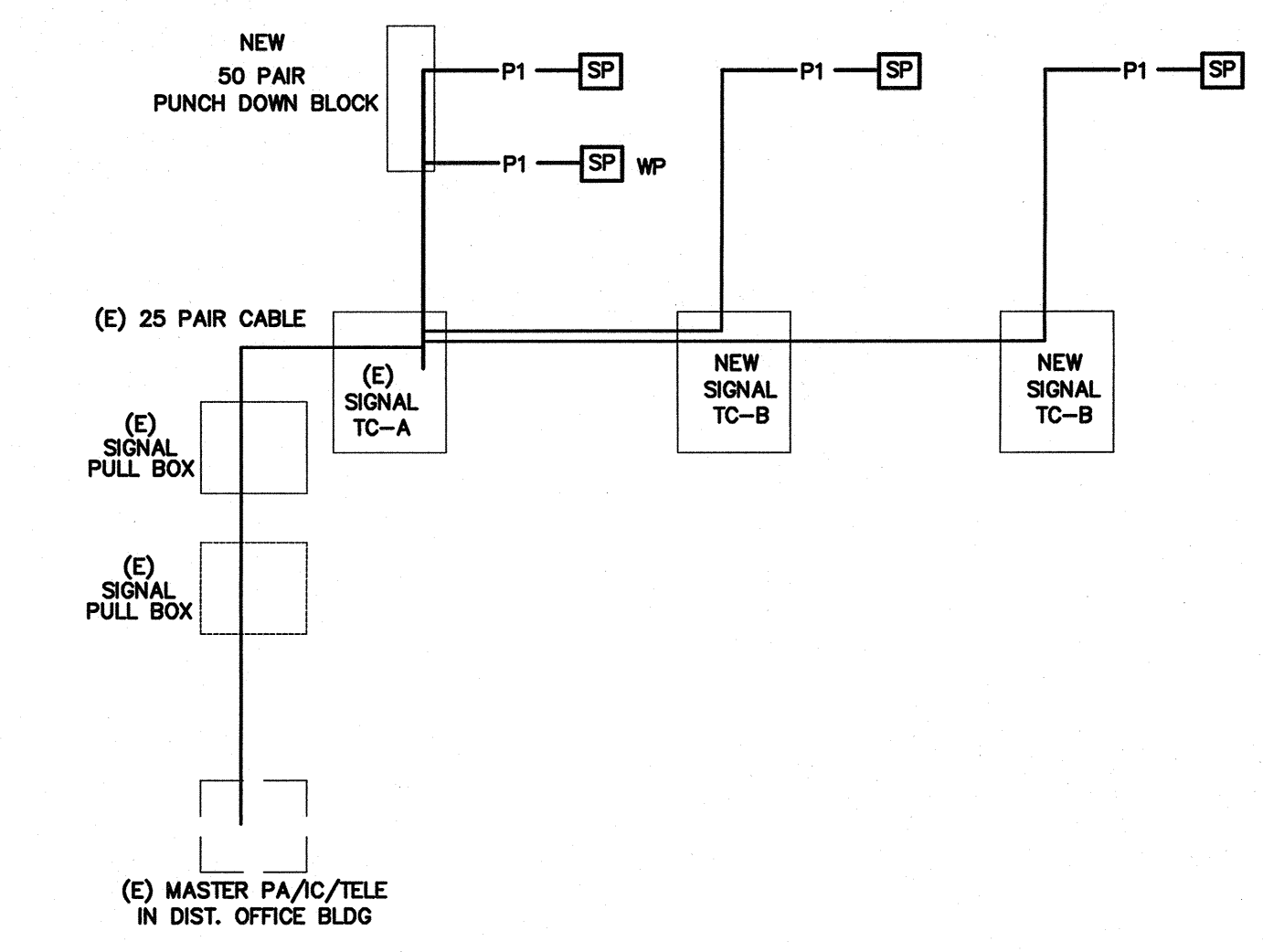

6 PA/IC/TELE SYSTEM RISER DIAGRAM N.T.S

**FIBER OPTIC CABLE**  
THREE MULTIMODE PAIRS (SIX STRANDS) AND THREE SINGLE-MODE PAIRS (SIX STRANDS)  
OPTICAL CABLE COMPANY # DX 12/065D-6W3S8/1UC-6SYMC-YMD/900-0FNR OF EQUAL  
**CAUSE CABLE**  
SENPA24-BL-BER-PV OR EQUAL  
**CABLE TESTING**  
ALL FIBER OPTIC CABLE MUST BE TESTED TO SUPPORT 1000BASE-FX FULL DUPLEX STANDARDS.  
ALL CAT 5E CABLE MUST BE TESTED TO SUPPORT 100BASE-TX.  
TEST RESULTS ARE TO BE PROVIDED TO SCHOOL TECHNOLOGICAL SERVICES FOR REVIEW AND APPROVAL.

**IDF SWITCH EQUIPMENT**  
F/O CISCO WS-C2950C-24 W/ WS-C5484 GBIC  
TP CISCO WS-C2950-24  
CABINETS SOUTH WESTERN DATA PRODUCT SWE 4000-18UBDLK OR EQUAL  
JACKS ALLEN TEL AT55-16 OR EQUAL  
FACEPLATE ALLEN TEL AT50-2-09 OR EQUAL  
PATCH PANEL ALLEN TEL ATPNL-24 OR EQUAL

**LABELING IDENTIFICATION**  
ALL INSTALLED EQUIPMENT, CABLES, TERMINATIONS, ETC. WILL BE PERMANENTLY AND UNIQUELY MARKED. CABLES WILL BE MARKED USING A CONVENTION THAT WILL IDENTIFY ITS ORIGIN AND DESTINATION. LAN TERMINATIONS WILL SIMILARLY BE MARKED TO UNIQUELY IDENTIFY THEM WHILE PROVIDING THE SOURCE AND DESTINATION OF CABLE. IDENTIFICATIONS MUST BE SUCH THAT THEY WILL NOT RUB OFF, FALL OFF, OR EASILY BREAK AWAY.

**DATA COMMUNICATION SYSTEM NOTES**  
1. CONTRACTOR TO PROVIDE ALL EQUIPMENT, PATCH CABLE AND ACCESSORY FOR A FULLY FUNCTIONAL SYSTEM.  
2. NEW DATA JACK WIRING CONFIGURATION MUST BE MATCHED EXISTING SYSTEM. FIELD VERIFY PRIOR TO INSTALLATION.  
3. ADMINISTRATIVE NODE TO BE RED IN COLOR WITH THE INSTRUCTIONAL NODE TO BE BLUE IN COLOR. NODE LOCATION MUST BE 12" WITHIN POWER RECEPTACLE AND FIELD VERIFY EXACT LOCATION WITH OWNER PROJECT COORDINATOR OR TECHNOLOGICAL SERVICES PERSONNEL PRIOR TO INSTALLATION.  
4. ALL EQUIPMENT DOCUMENTATION AND WARRANTY INFORMATION WILL BE PROVIDED TO OWNER TECHNOLOGICAL SERVICES. WARRANTY CARDS WILL BE PROVIDED TO VUSD TECHNOLOGICAL SERVICES FOR FILING WITH MANUFACTURERS UPON COMPLETION OF INSTALLATION.

7 DATA COMMUNICATION SYSTEM RISER DIAGRAM N.T.S

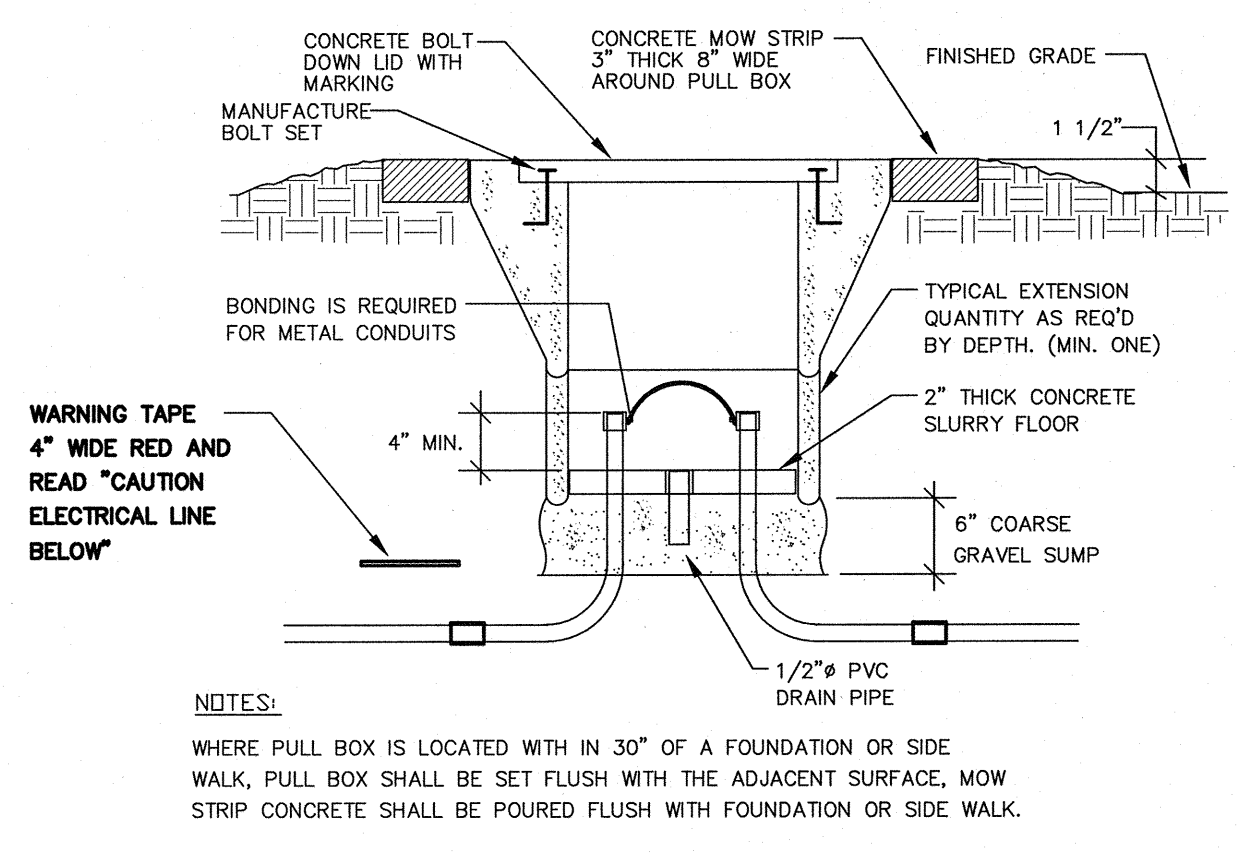

4 PULL BOX AT OPEN YARD DETAIL N.T.S

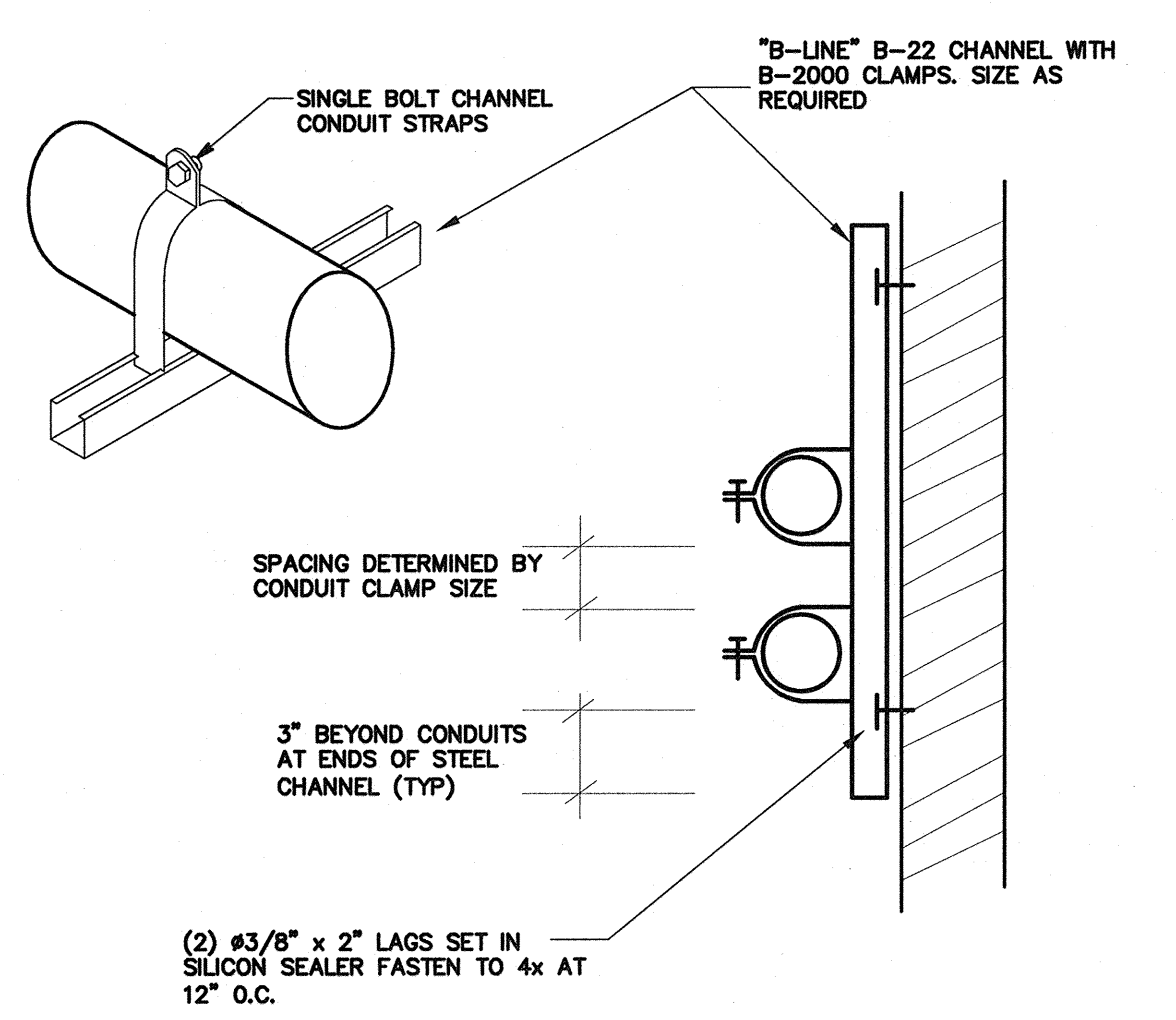

6 CONDUIT SUPPORT DETAIL N.T.S

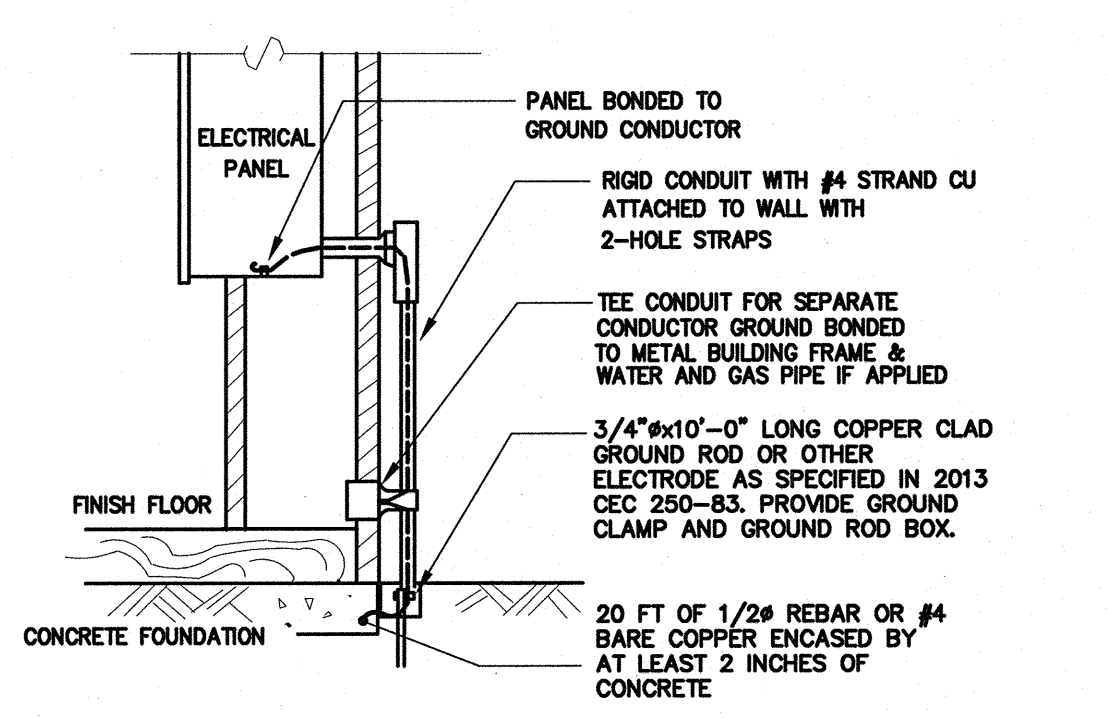

3 GROUNDING DETAIL N.T.S

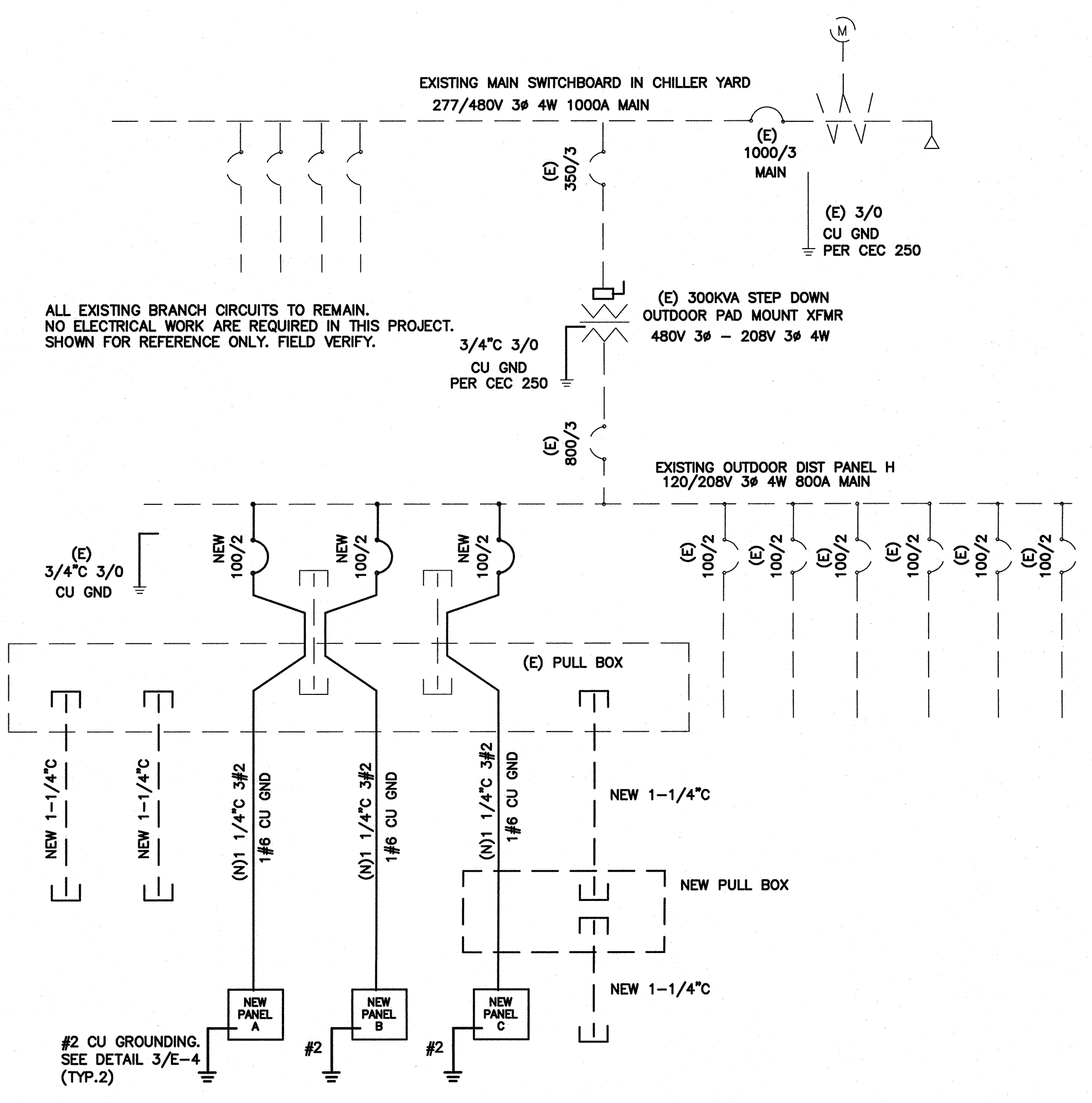

1 SINGLE LINE DIAGRAM N.T.S

ALL EXISTING BRANCH CIRCUITS TO REMAIN. NO ELECTRICAL WORK ARE REQUIRED IN THIS PROJECT. SHOWN FOR REFERENCE ONLY. FIELD VERIFY.

- NOTES:**
1. PROVIDE NEW MATCHING BREAKERS, FEEDERS AND PANELS PER PLANS.
  2. ALL NEW CONDUCTOR SHALL BE 75°C THWN-2 COPPER IN CONDUIT. (AMPACITY FOR CONDUCTOR SELECTION MUST BE DETERMINED/DERATED BY THE ALLOWED TERMINATION RATINGS MARKED/APPROVED ON EACH DEVICES, MOTOR, APPLIANCE, XFMR O.C.P.C. PANEL, ETC. CONDUCTORS INSTALLED IN U.G OR WET LOCATIONS SHALL BE MARKER 'W'. PER 2013 CEC 110-14(C)(1).)
  3. ALL WIRING OVER 100 VOLT SHALL BE INSTALLED IN RACEWAY CONDUIT, EMT ABOVE GRADE, PVC SCH. 40 BELOW GRAD AND STEEL CONDUIT ON EXPOSE SURFACE BELOW 8' AFF. FOR PHYSICAL PROTECTION.
  4. MC CABLE WITH SEPARATE GROUND CONDUCTOR CAN BE USED IN CEILING AND CONCEAL IN WALL.
  5. STEEL BACK BOX SHALL BE PROVIDE FOR ALL NEW ELECTRICAL DEVICES SUCH AS SWITCH, OUTLET AND CONDUCTOR SPLICE.
  6. ELECTRICAL CONTRACTOR IS RESPONSIBLE TO VERIFY THE EXISTING SWITCHBOARD AND PANELS ARE INSTALL PER ONE LINE DIAGRAM PRIOR TO WORKING, AND REPORT TO ENGINEERS IF ANY DISCREPANCY ARE FOUND.

CONSULTING ENGINEERS  
**John Chong ENGINEERING**  
2017 E. DELATUR AVE, FRESNO CA 95710  
(559) 915-9266 • FAX 251-2421  
jchenginer@o1.com

REGISTERED PROFESSIONAL ENGINEER  
JOHN S. CHONG  
E 14419  
Exp. 6/30/2016  
ELECTRICAL  
STATE OF CALIFORNIA

Ownership of Documents  
This document, the ideas and designs incorporated herein, as an instrument of Professional Service is the property of Integrated Designs by SOMAM Inc. and is not to be used, in whole or in part for any other project without written authorization.  
© COPYRIGHT 2013

**integrated designs** by SOMAM, Inc.  
ARCHITECTURE - ENGINEERING - INTERIOR DESIGN - CONSTRUCTION MANAGEMENT  
6011 N. Fresno, Suite 100 - Fresno, California 95710  
Phone: (559) 436-0687 Fax: (559) 436-0681 E-Mail: design@somam.com  
www.integrateddesigns.com

Revision	Revision Description	Rev. Date

DETAILS AND SYSTEM DIAGRAMS

Project Name & Address:  
**FREMONT ELEMENTARY SCHOOL  
3 RELOCATABLE CLASSROOMS**  
BAKERSFIELD CITY SCHOOL DISTRICT  
607 TEXAS STREET, BAKERSFIELD, CA

Issue Date: 00/00/14  
Date: 05/28/14  
Designer: J. CHONG  
DR: J. CHONG  
PC: CJM

Agency Approval Stamp:  
FILE # 15-6  
IDENTIFICATION STAMP  
DIV. OF THE STATE ARCHITECT  
OFFICE OF REGULATION SERVICES  
115890  
AC: JLV FLS CO SS JP  
DATE: 7/24/14  
TRACKING #: DSA TRACKING NO

Stamp(s):

Job No.: **5124**

Sheet No.: **E-4**

Release:

7/8/2014 8:26:20 AM

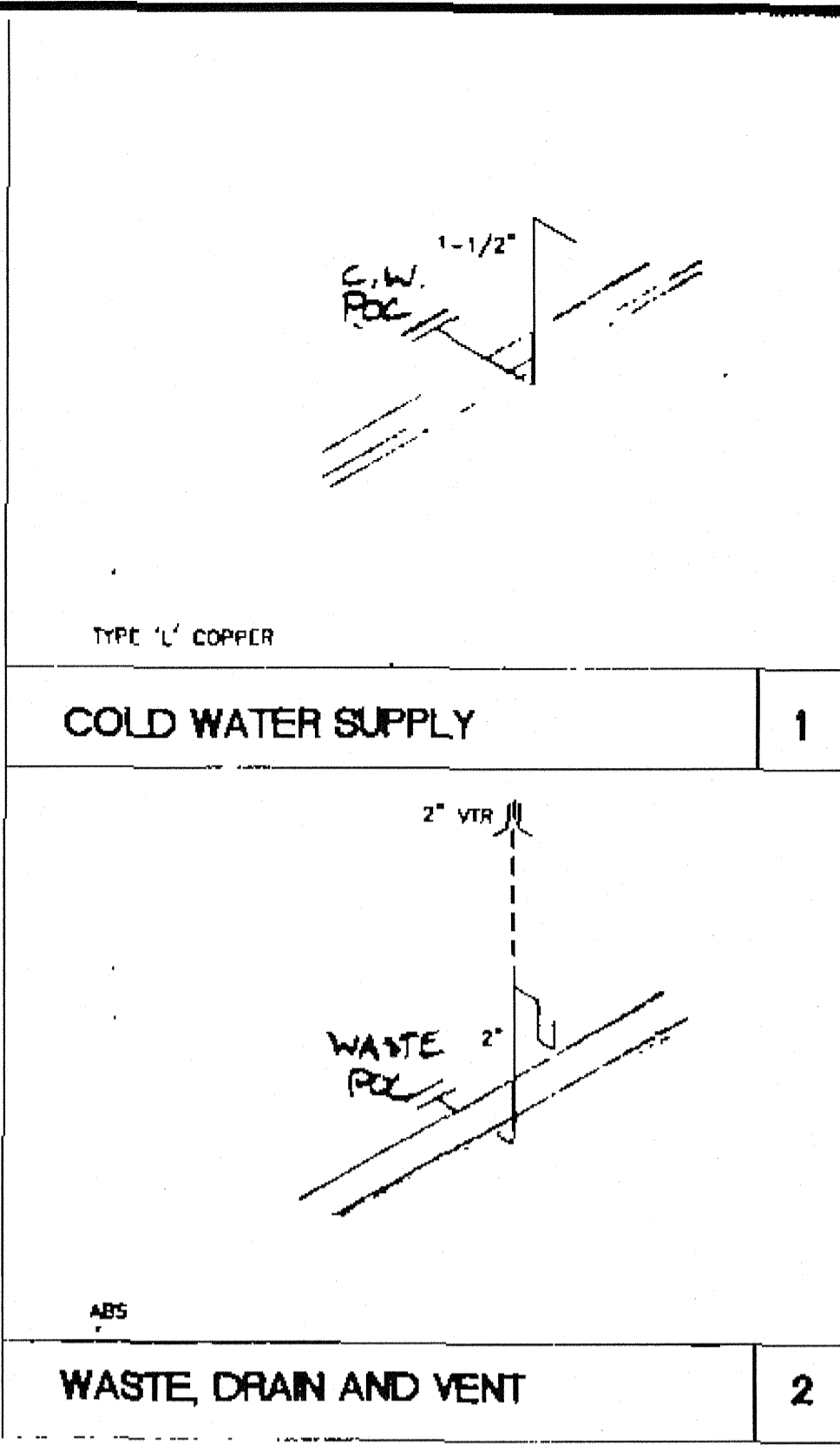
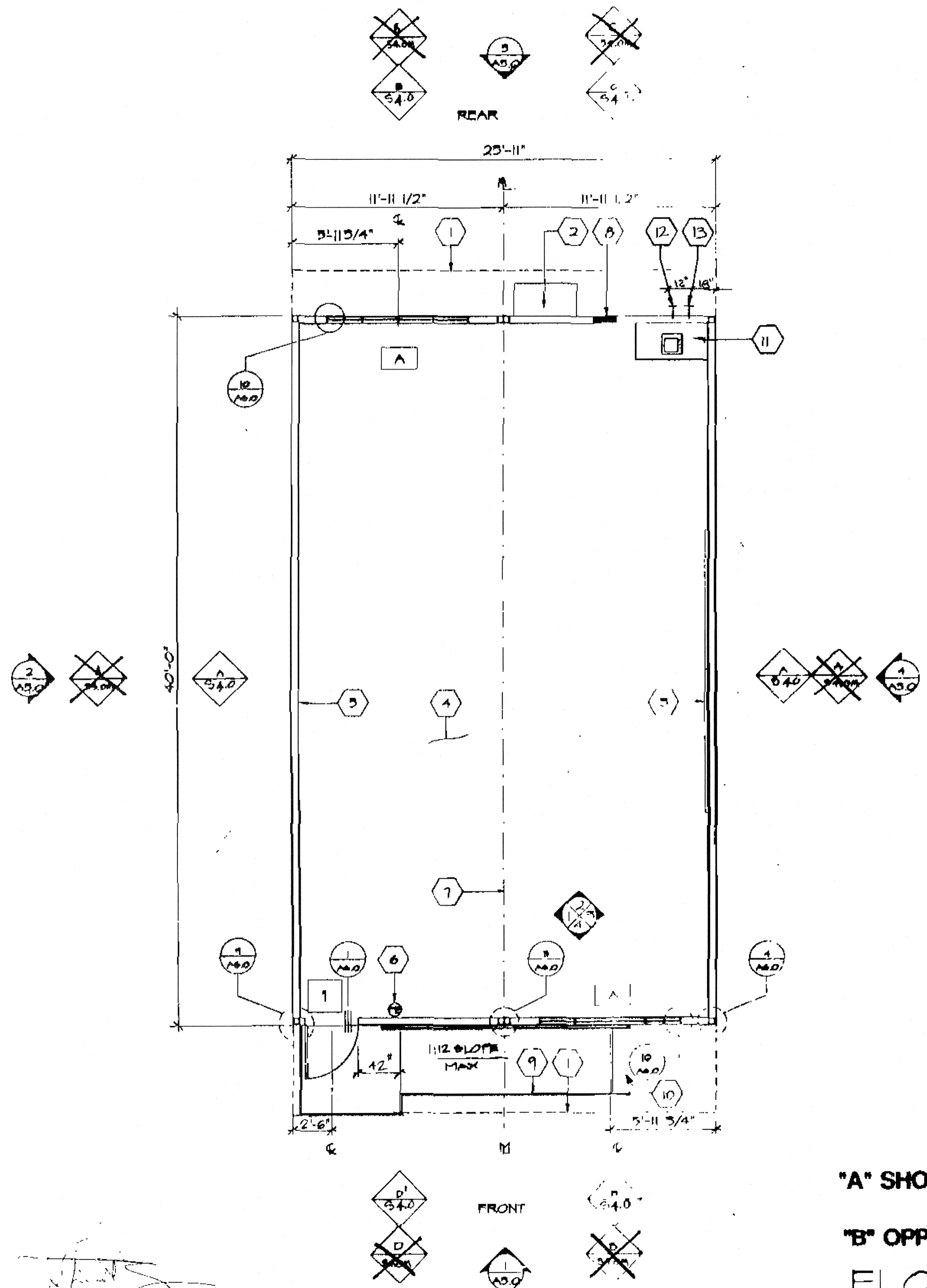

NOTE:  
SINK CABINET OPTIONAL

**LEGEND**

- 1 EXTERIOR DOOR SEE DOOR SCHEDULE
- A WINDOW (SEE SCHED. A5.0)

**KEY NOTES**

- 1 ROOF OVERHANG
  - 2 HVAC UNIT - SEE M-1.0
  - 3 2- 8'x4' MARKER BOARDS (SEE SPEC'S FOR TYPE)
  - 4 FINISH FLOORING (SEE FINISH SCHED.)
  - 5 TYPICAL INTERIOR FINISH (SEE FINISH SCHED.)
  - 6 FIRE EXTINGUISHER - 5 LBS. DRY CHEMICAL WITH 2A-10BC U.L. RATING ON WALL MTD. RE. HANDLE AT 40"
  - 7 MODLINE (BY TYPICAL)
  - 8 ELECTRICAL PANEL (SEE E1.0)
  - 9 RAMP (SEE R1.0 & R2.0)
  - 10 RAMP LANDING SEE DET. 11 ON SH. RZ.0
  - 11 ACCESSIBLE SINK CABINET. SEE A4.0 SINK: CRA-1725-A GR. 5" DEEP FAUCET: CHICAGO 350. BUBBLER: USB 10
  - 12 COLD WATER PDC.
  - 13 WASTE PDC.
- A. METAL TAG ON ALL MODULES. MECHANICALLY ATTACHED TO REAR EXTERIOR OF BUILDING SHOWING DSA APPLICATION NUMBER, MANUFACTURER'S NAME AND SERIAL NUMBER AND ROOF & FLOOR DESIGN LIVE LOAD.

"A" SHOWN  
"B" OPPOSITE  
FLOOR PLAN

INTERIOR REFERENCE  
SHEET A4.0

SCALE 1/4"=1'-0"

REVISED

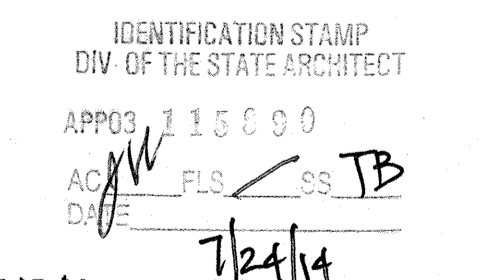
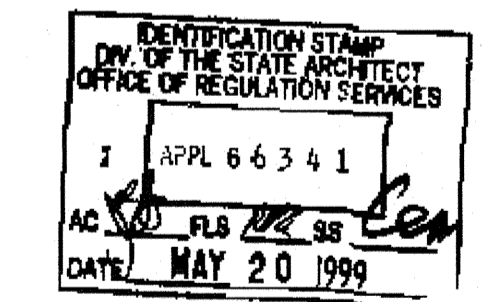

1/32/15 DSA HANDICAP REVISIONS

ARCHITECT	ELECTRICAL	STRUCTURAL	MECHANICAL	FIRE MARSHAL	ACCESS COMPLIANCE	STRUCTURAL SAFETY
-----------	------------	------------	------------	--------------	-------------------	-------------------

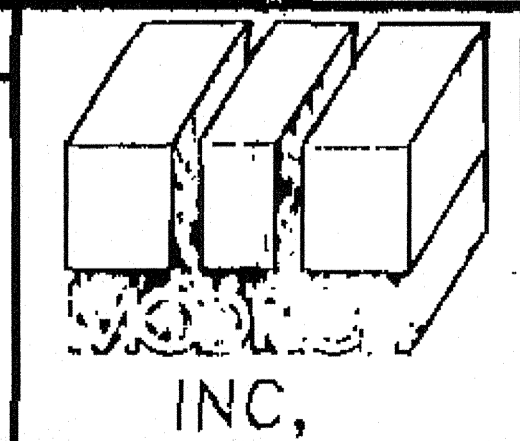
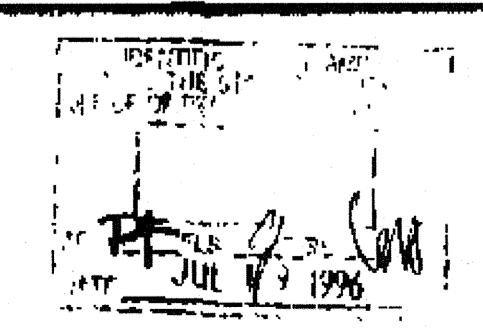
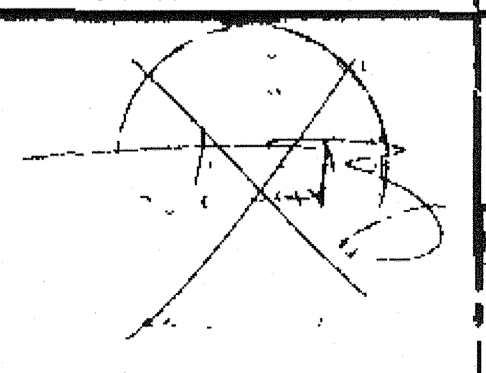

**FLOOR PLAN**

**A1.0A**

**LEGEND**

- 1 EXTERIOR DOOR (SEE DOOR SCHED)
- A EXTERIOR WINDOW (SEE FINISH SCHED)

**KEY NOTES**

- 1 TYPICAL EXTERIOR SIDING (SEE FINISH SCHED)
- 2 EXTERIOR LIGHT FIXTURE (SEE SPECIFICATIONS)
- 3 TOP OF SKIRTING
- 4 RAMP AND LANDING (SEE SHT R-1.0)
- 5 HVAC UNIT (SEE SHT M-1)
- 6 DOWNSPOUT (TYP); FASTEN TO DUG-TYPE 2 PLACES (SEE (Y/A/G-1))
- 7 CONTINUOUS GUTTER WITH DOWNSPOUT (LOCATION OF DOWNSPOUT SHOWN ON ROOF PLAN A2.0)
- 8 SPLASH BLOCK (BY OTHERS)
- 9 FINISH FLOOR LINE
- 10 BOTTOM FLANGE OF FLOOR BEAM
- 11 ROOF HEADER
- 12 VENT (SEE FOUNDATION PLAN)
- 13 FINISH GRADE
- 14 ROOF BEAM (SEE STRUCTURAL)
- 15 COLUMN (SEE STRUCTURAL)
- 16 ELECTRICAL STUD-OUT 1 1/4" Ø (TYPICAL)
- 17 GROUND STUD-OUT 1/2" Ø (TYPICAL)
- 18 FIRE ALARM HORN NIC.
- 19 NEMA 6"x6" GUTTER DOWN
- 20 FIDUCIAL

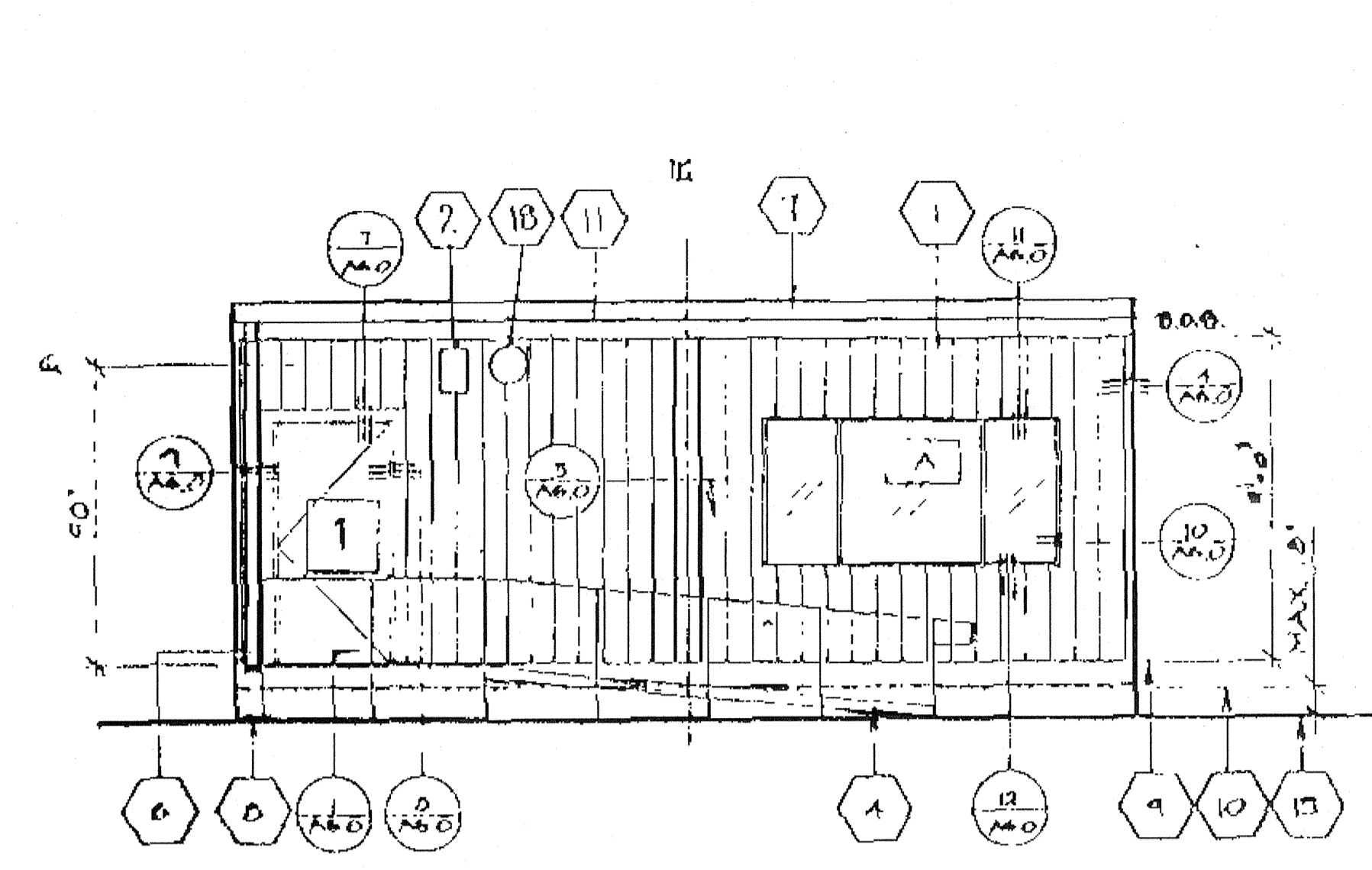

① FRONT ELEVATION

SCALE 1/4"=1'-0"

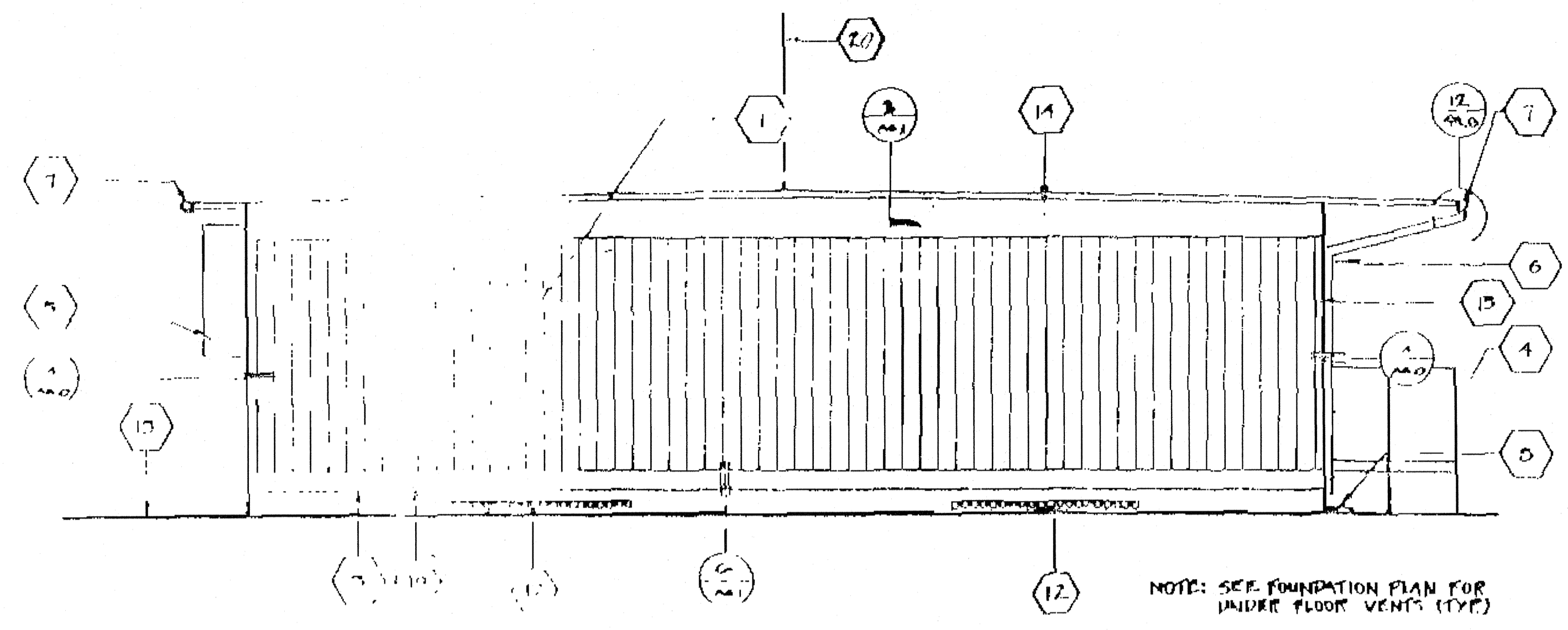

② SIDE ELEVATION

SCALE 1/4"=1'-0"

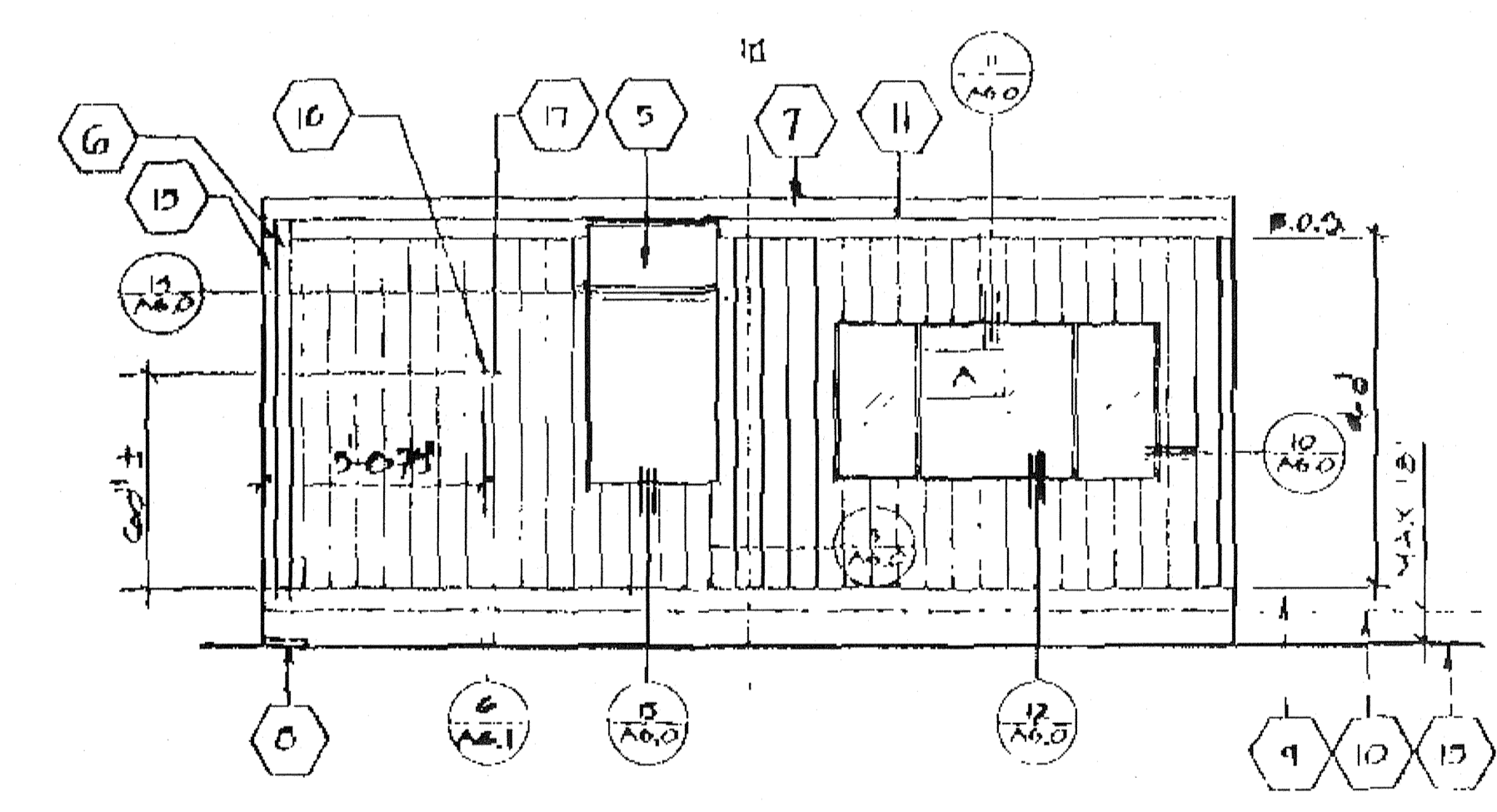

③ REAR ELEVATION

SCALE 1/4"=1'-0"

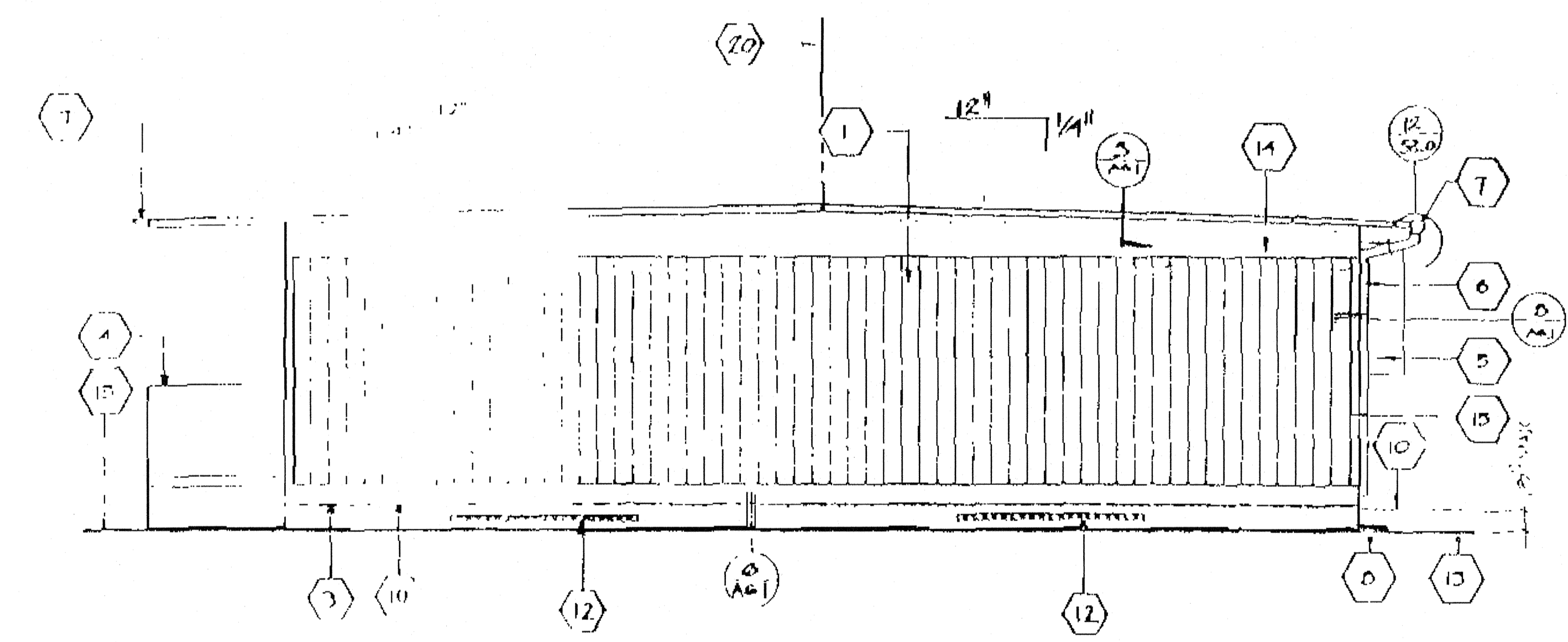

④ SIDE ELEVATION

SCALE 1/4"=1'-0"

NOTE:  
SEE FOUNDATION PLAN FOR  
VENT SIZE & LOCATION

"A" SHOWN  
"B" OPPOSITE

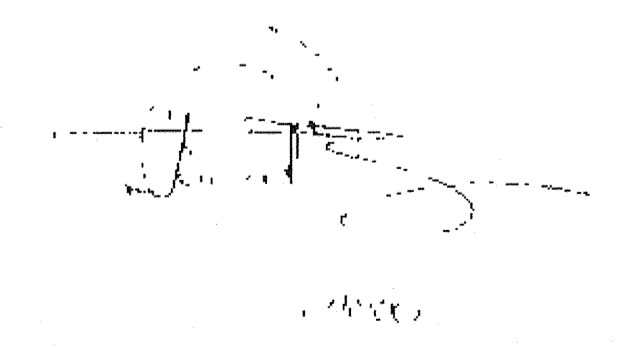

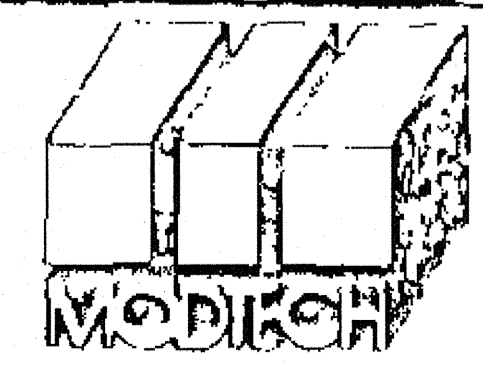
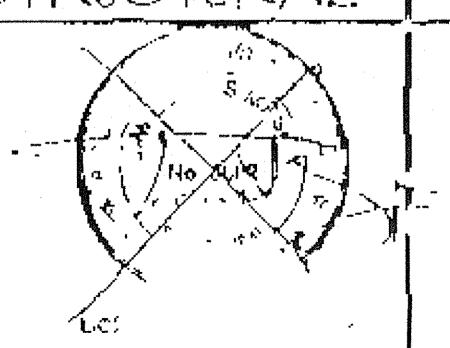
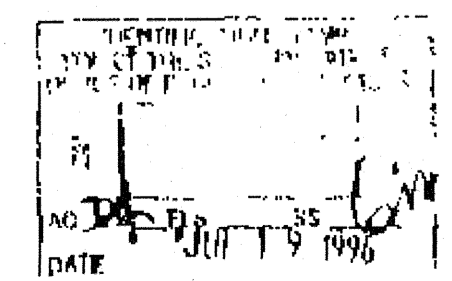
ARCHITECT	ELECTRICAL	STRUCTURAL	MECHANICAL	FIRE MARSHAL	ACCESS COMPLIANCE	STRUCTURAL SAFETY	
							<p>IDENTIFICATION STAMP CIVIL ENGINEER APPROX 110000 AC 11/15/96 DATE 11/1/96</p> <p>SCALE: 1/4"=1'-0"</p> <p>24'X40' DUAL PITCH A3-0A</p>

# PC 275 RELOCATABLE BUILDING (S) FOR G E CAPITAL STOCKPILE (1065) 24' X 40' BUILDINGS

SYMBOLS		
TYPE	SYMBOL	DESCRIPTION
DETAIL		DETAIL ON SAME SHEET AS SYMBOL
DETAIL		DETAIL NUMBER (1) ON SHEET NUMBER (2)
NOTE		NOTE NO. 1 ON SAME SHEET AS SYMBOL
NOTE		NOTE NO. 4 ON SHEET NUMBER (2)
WALL PANEL		WALL PANEL TYPE 'A' ON SHEET (1)
SECTION		SECTION 'A' ON SHEET (2)
REV		REVISION CHANGE IN DRAW NO. (1) FIRST REVISION
REV		REVISIONS CHANGED AREA
REFERENCE		DOOR REFERENCE
REFERENCE		WINDOW REFERENCE

JOB 2425: (15) BUILDINGS

SERIAL NOS: 22333 THRU 22342

JOB 2430: (450) BUILDINGS

SERIAL NOS: 22487 THRU 22524

JOB 2667: (600) BUILDINGS

SERIAL NOS: 29620 THRU 30619

## SHEET INDEX

ARCHITECTURAL	A.0 - COVER SHEET A1.0A - FLOOR PLAN (24X40) A1.0B - FLOOR PLAN (24X40) A2.0 - ROOF PLAN (24X40) MONO PITCH A2.1 - ROOF PLAN (24X40) MONO PITCH A2.2 - ROOF PLAN (24X40) DUAL PITCH A2.3 - ROOF PLAN (24X40) DUAL PITCH A2.4 - ROOF PLAN (24X40) MONO PITCH A2.5 - EXTERIOR ELEVATION (24X40) MONO PITCH A2.6 - EXTERIOR ELEVATION (24X40) DUAL PITCH A3.0A - EXTERIOR ELEVATION (24X40) MONO PITCH A3.0B - EXTERIOR ELEVATION (24X40) DUAL PITCH A3.1A - EXTERIOR ELEVATION (24X40) MONO PITCH A3.1B - EXTERIOR ELEVATION (24X40) DUAL PITCH A4.0 - INTERIOR ELEVATIONS (24X40) A4.1 - INTERIOR ELEVATIONS (24X40) A4.2 - INTERIOR ELEVATIONS (24X40) A5.0 - FINISH SCHEDULE A6.0M - ARCHITECTURAL DETAILS METAL STUDS A6.0N - ARCHITECTURAL DETAILS METAL STUDS A6.0O - ARCHITECTURAL DETAILS WOOD STUDS A6.0P - ARCHITECTURAL DETAILS WOOD STUDS A7.0A - REFLECTED CEILING PLAN (24X40) A7.0B - REFLECTED CEILING PLAN (24X40) A7.1 - REFLECTED CEILING DETAILS
STRUCTURAL	F0.1 - FOUNDATION PLAN (24X40) SOFT FLOOR F0.2 - FOUNDATION PLAN (24X40) SOFT FLOOR F1.1 - FOUNDATION PLAN (24X40) SOFT FLOOR F1.2 - FOUNDATION PLAN (24X40) SOFT FLOOR F2.1 - FOUNDATION PLAN (MONO) SOFT FLOOR F2.2 - FOUNDATION PLAN (DUAL) SOFT FLOOR F3.0 - FOUNDATION DETAILS HOOD F4.0 - FOUNDATION PLAN (SOFT) (CONCRETE) F4.1 - FOUNDATION PLAN (SOFT) (CONCRETE) F4.2 - FOUNDATION PLAN (SOFT) (CONCRETE) F4.3 - FOUNDATION PLAN (SOFT) (CONCRETE) F4.4 - FOUNDATION PLAN (SOFT) (CONCRETE) F5.0 - FLOOR FRAMING PLAN (TYP 90 PSF) F5.1 - FLOOR FRAMING PLAN (TYP 90 PSF) F5.2 - FLOOR FRAMING DETAILS (TYPICAL) F5.2A - FLOOR FRAMING DETAILS (TYPICAL) F5.2B - FLOOR FRAMING DETAILS (TYPICAL) F5.3 - ROOF FRAMING PLAN (TYP DUAL PITCH) F5.4 - ROOF FRAMING PLAN (TYP DUAL PITCH) F5.5 - ROOF FRAMING PLAN (TYP DUAL PITCH) F5.6 - STRUCTURAL ELEVATIONS AND DETAILS (MONO PITCH) F5.6A - STRUCTURAL ELEVATIONS AND DETAILS (DUAL PITCH) F5.7M - WALL FRAMING (METAL) F5.7O - WALL FRAMING (WOOD) F5.8M - FRAMING DETAILS (METAL) F5.8N - FRAMING DETAILS (METAL) F5.9 - FRAMING DETAILS (WOOD) F5.9 - FRAMING DETAILS (WOOD) F5.1 - FRAMING DETAILS (WOOD)
MECHANICAL	M1.0A - HVAC (HVAC) PLAN (24X40) M2.0 - HVAC (HVAC) PLAN (24X40) M3.0 - HVAC (HVAC) PLAN (24X40) M4.0 - HVAC PLAN (24X40)
ELECTRICAL	E1.0A - ELECTRICAL PLAN (24X40) E2.0 - ELECTRICAL PLAN (24X40) E3.0 - ELECTRICAL PLAN (24X40) E4.0B - ELECTRICAL PLAN (24X40)
RAMP	R1.0 - RAMP PLAN R2.0 - RAMP DETAILS

REVISED

BUILDING DATA	
24'X40' BUILDING	
OCCUPANCY	E-2
TYPE OF CONSTRUCTION	V-M
WIND LOAD	70 MPH. EX'R.C.
FLOOR LIVE LOAD	20 PSF.
ROOF LIVE LOAD	20 PSF. REDUCIBLE FOR AREA
SEILING AREA	960 PSF
STRUCTURAL SYSTEM	RIGID FRAME

NO ALTERATIONS PERMITTED FOR ALL SHEET FOR ATTACHMENT TO USE IN OTHER PROJECTS AT THE SAME ADDRESS.

SPECIFICATIONS SUBJECT TO CHANGE DUE TO PRODUCT IMPROVEMENT

### APPLICABLE CODES - NEW CONSTRUCTION

1994 UBC AND 1995 CALIFORNIA AMENDMENTS (15 CALIFORNIA BUILDING CODE - PART 2, TITLE 24, C.C.R.U.)  
1993 NEC AND 1995 CALIFORNIA AMENDMENTS (15 CALIFORNIA ELECTRICAL CODE - PART 5, TITLE 24, C.C.R.U.)  
1994 MFC AND 1995 CALIFORNIA AMENDMENTS (15 CALIFORNIA MECHANICAL CODE - PART 4, TITLE 24, C.C.R.U.)  
1994 UPC AND 1995 CALIFORNIA AMENDMENTS (15 CALIFORNIA PLUMBING CODE - PART 5, TITLE 24, C.C.R.U.)  
1994 UNIFORM FIRE CODE WITH STATE AMENDMENTS (CALIFORNIA FIRE CODE - PART 1, TITLE 24, C.C.R.U.)  
1994 BUILDING STANDARDS CODE WITH STATE AMENDMENTS (STATE REFERENCED STANDARDS CODE - PART 12, TITLE 24, C.C.R.U.)  
TITLE 19, C.C.R., PUBLIC SAFETY, STATE FIRE MARSHALL REGULATIONS.

BY THE SIGNATURE OF THE ARCHITECT, HE ACCEPTS RESPONSIBILITY FOR THE DESIGN OF THIS PROJECT AND FOR THE CORRECTNESS OF THE INFORMATION CONTAINED THEREIN. HE ALSO ACCEPTS RESPONSIBILITY FOR THE DESIGN OF THIS PROJECT AND FOR THE CORRECTNESS OF THE INFORMATION CONTAINED THEREIN.

IDENTIFICATION STAMP  
DIV. OF THE STATE ARCHITECT  
OFFICE OF REGULATION SERVICES  
66341  
DATE: MAY 20, 1999

ACR: J. SCHUBER  
FLS: R. ALLAN  
SS: G. HANES

APPROVED  
DATE: 12/24/97  
SS: G. HANES

ACR: D. FENNISON  
FLS: R. ALLAN  
SS: G. HANES

ARCHITECT FOR PC PLAN DUPLICATE OF RECORD: JAMES T. OMBRO ENR. ARCHITECTURAL ENGINEER 931 S. WITTICOR BLVD LA HABRA, CA 91709 (917) 977-7007	STRUCTURAL 	PC 275 DATE: 12/24/97 SS: G. HANES	REVISION QTY OF BLDGS 12/24/97	IDENTIFICATION STAMP DIV. OF THE STATE ARCHITECT APPROVED 115090 ACR: J. SCHUBER FLS: R. ALLAN DATE: 12/24/97	TITLE SHEET 1A
---	----------------	--	--------------------------------	--	----------------

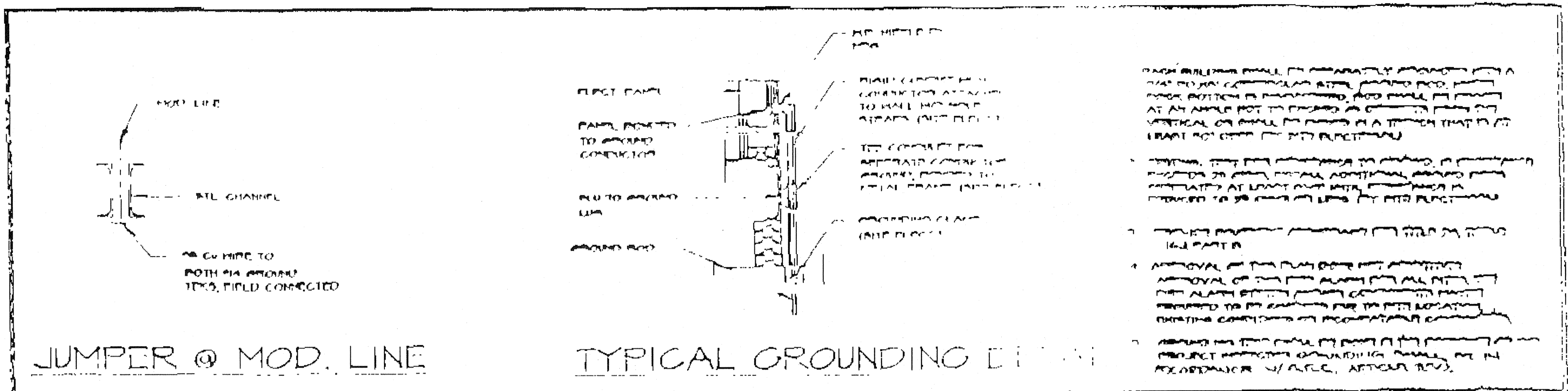

ANCHORING SHALL BE PROVIDED BY A TWO INCH ANCHOR BOLT AND SHALL BE PROTECTED BY AN ANGLE IRON OR CHINA PIPE AT AN ANGLE NOT TO EXCEED 45 DEGREES VERTICAL OR SHALL BE PROTECTED BY A TRENCH THAT IS AT LEAST 40 CM (16 IN) DEEP.

ANCHORING SHALL BE PROVIDED BY A TWO INCH ANCHOR BOLT AND SHALL BE PROTECTED BY AN ANGLE IRON OR CHINA PIPE AT AN ANGLE NOT TO EXCEED 45 DEGREES VERTICAL OR SHALL BE PROTECTED BY A TRENCH THAT IS AT LEAST 40 CM (16 IN) DEEP.

APPROVAL OF THE PLAN SHALL BE REQUIRED FOR ALL THE ELECTRICAL WORK. APPROVAL SHALL BE REQUIRED FOR ALL THE ELECTRICAL WORK. APPROVAL SHALL BE REQUIRED FOR ALL THE ELECTRICAL WORK.

SYMBOL	DESCRIPTION	QTY
[Symbol]	2 X 4 ALUMINUM ELECTRIC RACEWAY	
[Symbol]	1/2" RIGID PVC CONDUIT	
[Symbol]	CONDUIT FOR ELECTRICAL WIRE	
[Symbol]	CONDUIT FOR ELECTRICAL WIRE	
[Symbol]	CONDUIT FOR ELECTRICAL WIRE	
[Symbol]	CONDUIT FOR ELECTRICAL WIRE	
[Symbol]	CONDUIT FOR ELECTRICAL WIRE	
[Symbol]	CONDUIT FOR ELECTRICAL WIRE	
[Symbol]	CONDUIT FOR ELECTRICAL WIRE	
[Symbol]	CONDUIT FOR ELECTRICAL WIRE	
[Symbol]	CONDUIT FOR ELECTRICAL WIRE	
[Symbol]	CONDUIT FOR ELECTRICAL WIRE	

- NOTES**
1. 4" MIN. HEATED ROOF CUTTER DOOR (16x6x4)
  2. HVAC UNIT SEE CHIT #10
  3. ELECTRICAL PANEL "A"
  4. EXTERIOR LIGHT FIXTURE
  5. 1/2" INCH CON FOR FIRE ALARM OR BELL
  6. DUPLEX WALL RECEPTACLE IS-A 125-V 2-PHASE
  7. CLOCKS OUTLET (SEE SPEC'S)
  8. 2X4 FLUORESCENT LIGHT AND FIXTURE 4-REV. (SEE SPEC'S)

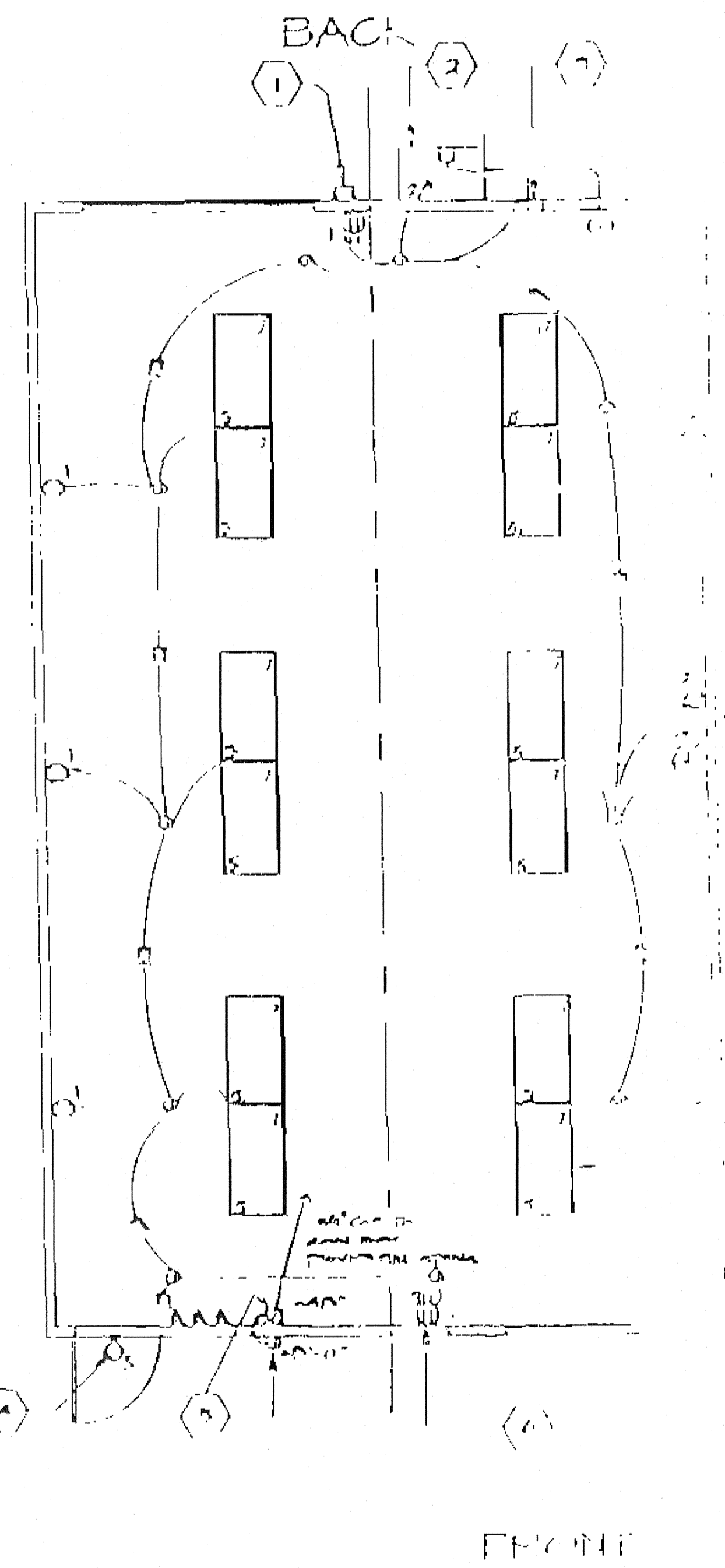

VOLTAGE	WATER	PANEL						FEED	LOAD
		AP	BP	CP	DP	EP	FP		
120V/208V	1/2"								
RECEPTACLES	1/2"	100	100	100	100	100	100	1000	HVAC WIRING
SWITCHES	1/2"	100	100	100	100	100	100	1000	HVAC WIRING
LINE LIGHTS	1/2"	100	100	100	100	100	100	1000	HVAC WIRING
FIRE ALARM	1/2"	100	100	100	100	100	100	1000	HVAC WIRING

WATER/PHASE A=120V B=208V C=208V D=208V E=208V F=208V

TOTAL 10,000 WATER 1000

NCL=116,000

- MOUNTING HEIGHTS**
- |                    |                 |
|--------------------|-----------------|
| TELEPHONE          | 12" MIN.        |
| RECEPTACLES        | 2'-0"           |
| EX. WALL OUTLET    | 4'-6"           |
| EX. WALL SWITCH    | 4'-6" MAX       |
| CLOCK OUTLET       | 4'-0"           |
| RAIN TIE OFF J BOX | 14" BETWEEN (1) |
| THEATRICAL         | 4'-6" MAX       |
| MAIN PANEL BOX     | 4'-0"           |
| SWITCHES           | 4'-6" MAX       |

**SCHOOL EQUIPMENT ANCHORAGE**

THE FOLLOWING IS FOR THE ELECTRICAL ENGINEER'S INFORMATION ONLY.

THE SEISMIC ANCHORAGE OF ELECTRICAL EQUIPMENT SHALL CONFORM TO E.C.A. TITLE 24, SECTION 2711 (4) AND TABLE 2711-A ANCHORAGE DETAILS FOR ANCHORAGE AND FASTENERS. ANCHORAGE SHALL BE PROVIDE FOR ALL EQUIPMENT EXCEPT THATS WHICH ARE LESS THAN 20 LBS. NOT BE GREATER FROM THE CEILING.

**FOR ELECTRICAL DRAWINGS:**

ALL ELECTRICAL EQUIPMENT SHALL BE BRACED OR ANCHORED TO RESIST A SEISMIC FORCE ACTING IN ANY DIRECTION USING THE FOLLOWING MATERIAL:

POWDER COAT	20% OF OPERATING WEIGHT
BRASS OR ALUMINUM	50% OF OPERATING WEIGHT

THIS EQUIPMENT MOUNTING SHALL USE A IN THE ABOVE VALUES AND FOR SMALL MOUNTS VERTICAL FORCE USE 1/3 A THE HORIZONTAL FORCE.

THE ABOVE VALUES ARE FOR AN RESISTANCE FACTOR 1 = 1.0 AND SEISMIC ZONE 1, 2 = 0.4

ANCHORING DETAILS ARE NOT SHOWN ON THE DRAWINGS THE FIELD INSTALLATION SHALL BE SUBJECT TO THE APPROVAL OF THE ELECTRICAL ENGINEER AND THE FIELD ENGINEER OF THE OFFICE OF THE STATE ARCHITECT.

**ELECTRICAL PLAN**

"A" SHOWN  
 1/8" OPPOSITE  
 SCALE 1/8" = 1'-0"

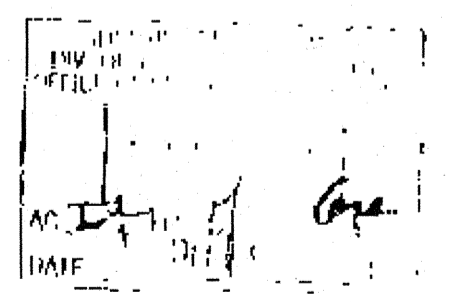

"MACHINE APPLIED 16d FASTENERS SHALL HAVE AN EMBEDMENT OF NOT LESS THAN 1/2" INTO SECOND MEMBER, AND SHALL BE NOT LESS THAN 3" IN OVERALL LENGTH"

THE ABOVE NAILS SHALL ALSO BE ACCEPTABLE FOR HAND NAILING, PROVIDED THE REQUIRED EMBEDMENT IS MAINTAINED

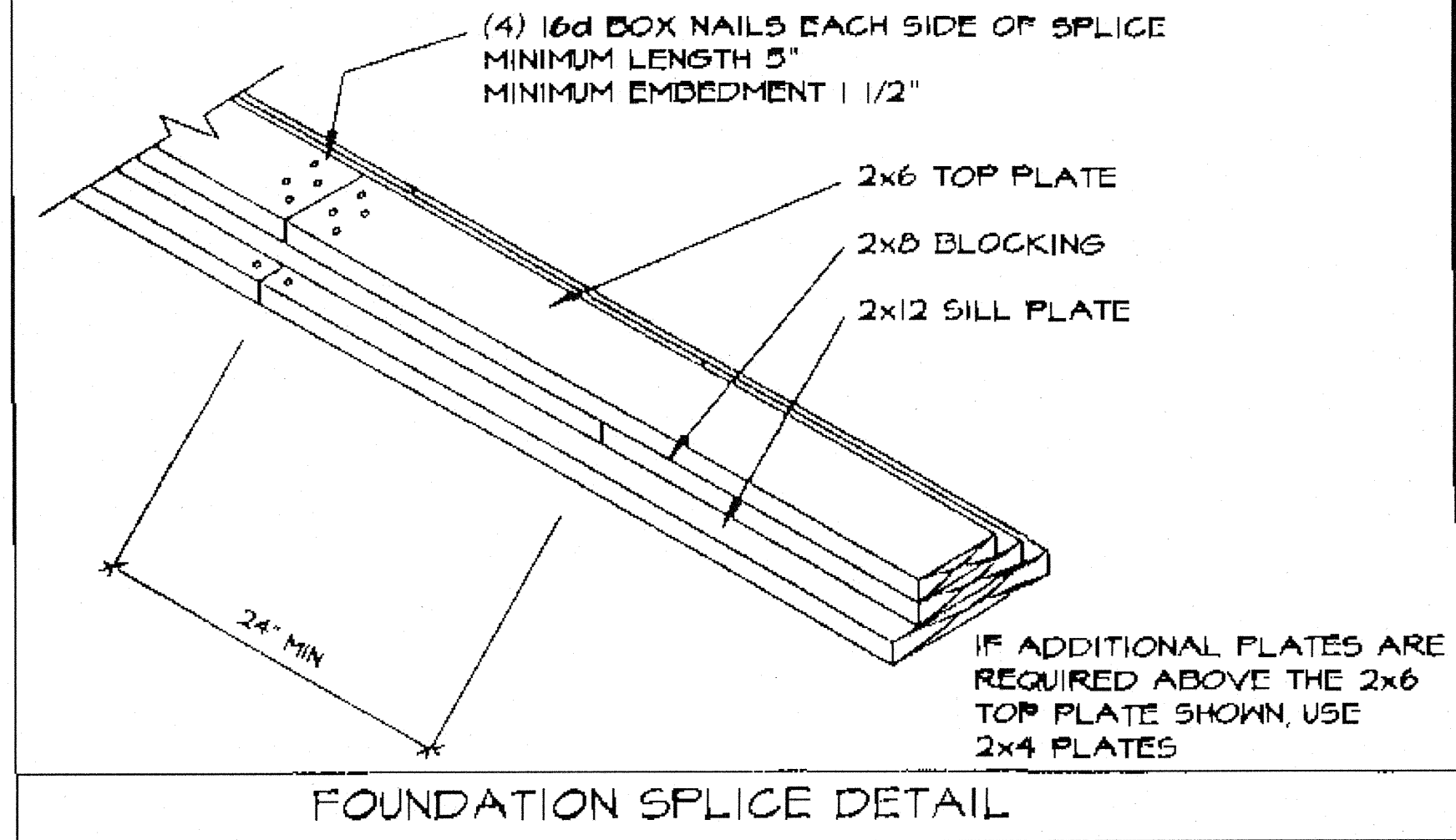

**KEY NOTES**

- 1 2"x6" SILL PLATE (END WALL)
- 2 6- 2X12X30" LONG SILL PADS
- 3 PIPE TO GRADE (TYP.)
- 4 3" HIGH BY 6'-6" LONG VENT
- 5 2X12 SILL PLATE (SIDE WALL)
- 6 4-2X12X30" LONG SILL PADS
- 7 6"x12"x10 GA. PLATES
- 8 1" Ø PIPE EA. END EA. PAD AT ADJ. BLDG. LINE
- 9 5/8" Ø X4" LAS (4-PER BLDG. MIN.)
- 10 6- 2X12X30" LONG SILL PADS

**GENERAL NOTES:**

- A. SOIL RESTRAINT: ON A.C. PAVING AND ON SOIL 1" O.D. GALVANIZED PIPE AT 10'-0" 12" PENETRATION BELOW SURFACE VERTICALLY. DRILL SILL 1-1/4" MAX. PIPE MAY BE DRIVEN MAX. OF 45° ANGLE TO VERTICAL. (10-1/2" LONG PIPE REQUIRED FOR PENETRATION AT 45° ANGLE)
- B. ON CONCRETE PAVING HILTI DS 82-PI0 THRU SILL PLATE:  
END WALLS: 8" O.C.  
SIDE WALLS: 22" O.C.
- C. WHERE SHIM STOCK IS REQUIRED FOR LEVELING USE 1/4", 1/2", OR 3/4" THICK PLYWOOD SAME WIDTH AS BLOCK. P.T.
- D. VERIFY DRAINAGE TO PREVENT WATER FROM PONDING BENEATH THE STRUCTURE WITH DISTRICT ARCHITECT SITE PLANS
- E. ALL FOUNDATION MATERIAL SHALL BE HEM FIR  
GROUND CONTACT: LP-22 (CCA 40)  
ABOVE GROUND: LP-2 (CCA 25)
- F. FOUNDATION DESIGNED FOR 1000 PSF SOIL BEARING PRESSURE PER ORS IR 25-6.  
ABOVE GROUND: LP-2

5" X 24" END WALL VENTS AS REQUIRED FOR ADJACENT BUILDING APPLICATIONS MIN. 10" FROM BLDG. CORNERS MIN. 10" FROM MODLINES MIN. 12" BLOCKING BETWEEN VENTS

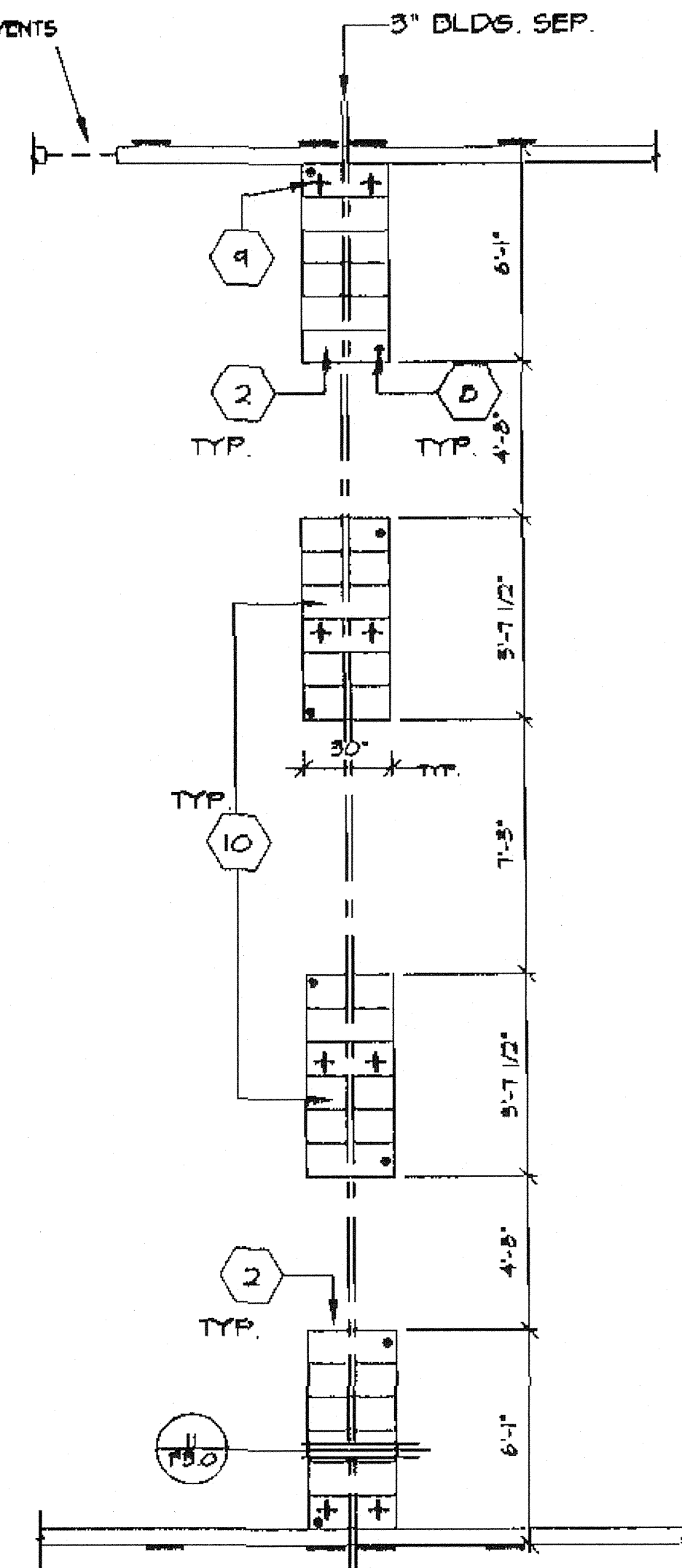

PAD FTG'S AT ADJ. BLDG.

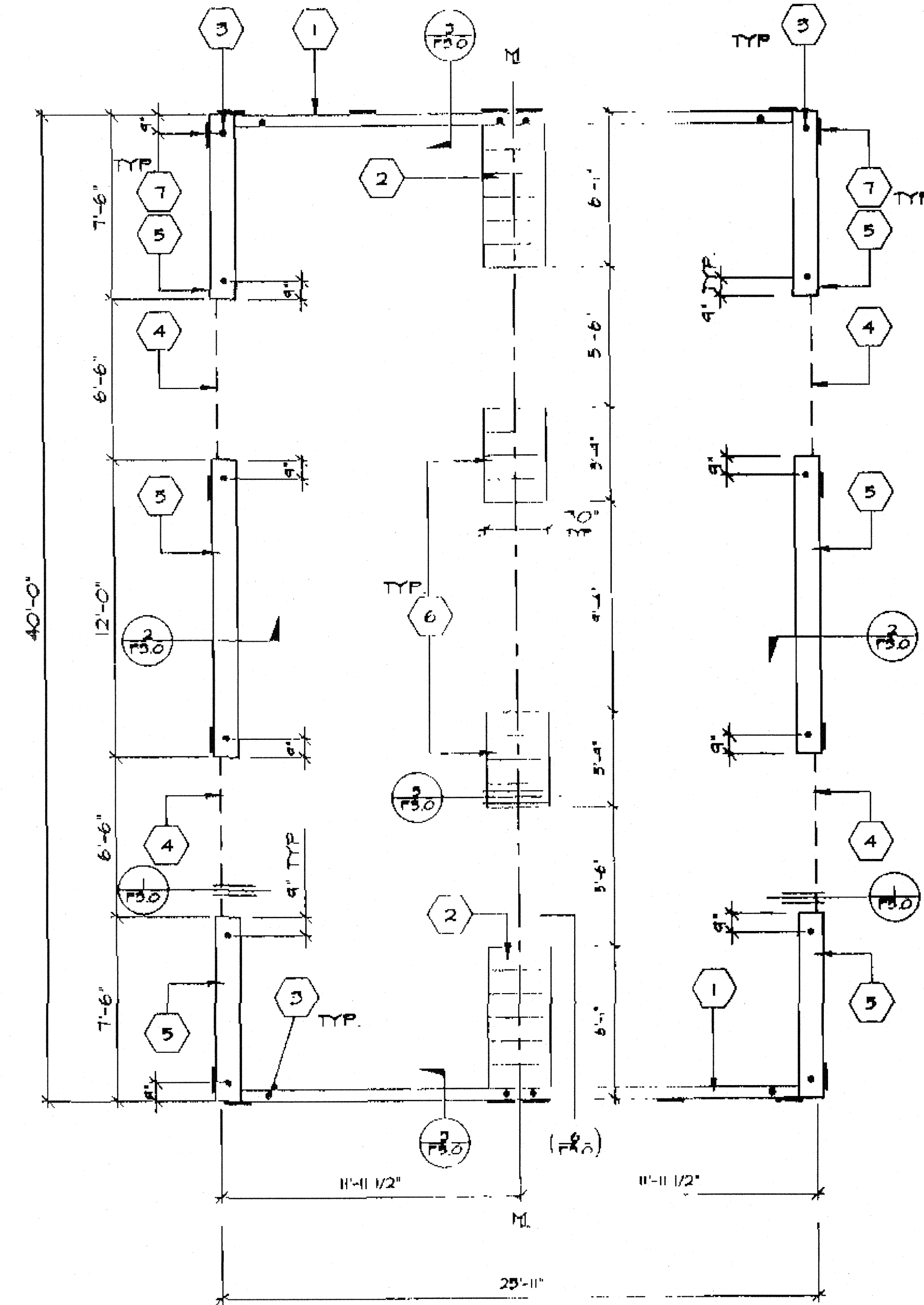

**VENT CALCS.**  
 BLDG'S SIZE 24' X 40' = 960 sq  
 VENTILATION REQ'D 960 ÷ 150 = 6.4 sq  
 3' X 6'-6" VENT = 1.625 sq  
 4 VENTS X 1.625 sq = 6.5 sq  
 6.5 sq > 6.4 sq

**FOUNDATION (WOOD SILL)**

24 x 40 - 50 PSF LL

SCALE 1/4"=1'-0"

REVISIONS

ELECTRICAL	MECHANICAL	STRUCTURAL	ARCHITECT	DIVISION OF THE STATE ARCHITECT
				<p>REVISED MAR 27 1996</p> <p>IDENTIFICATION STAMP            DIV. OF THE STATE ARCHITECT            OFFICE OF REGULATION SERVICES</p> <p>PC 275</p> <p>DATE 7/14/96</p>

**MODTECH INC.**  
 2830 BARRETT AVE.  
 PERRIS, CA. 92572  
 PH. (909) 943-4014  
 FX. (909) 940-0427

CONFIDENTIAL - THIS DOCUMENT AND THE INFORMATION CONTAINED HEREIN ARE THE PROPERTY OF MODTECH INC. UNAUTHORIZED COPYING, DISCLOSURE, OR OTHER UNAUTHORIZED USES ARE PROHIBITED

JOB NO. \_\_\_\_\_

IDENTIFICATION STAMP  
 DIV. OF THE STATE ARCHITECT

APPROX. 115000

AC. \_\_\_\_\_

DATE - DEC 11, 1996

7/24/96

**FOUNDATION PLAN**

DRAWN BY  
 DATE  
 CHECKED BY  
 DATE

**FO.**

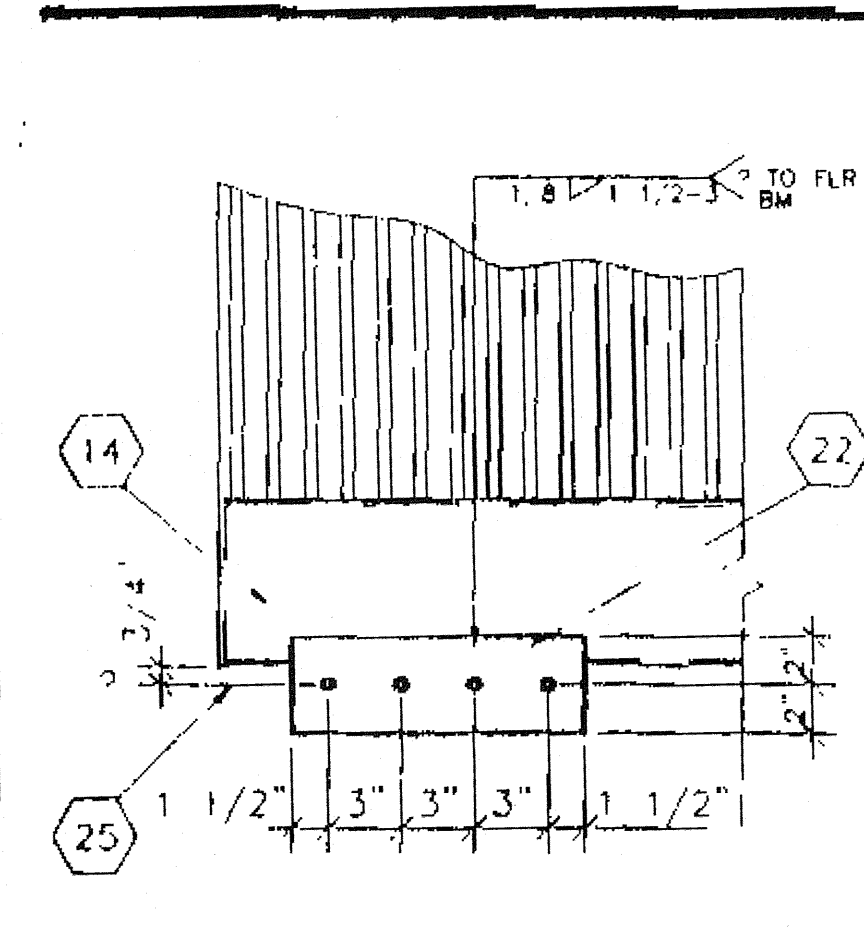

9 SCALE: 1 1/2"=1'-0"  
ALTERNATE HOLD DOWN

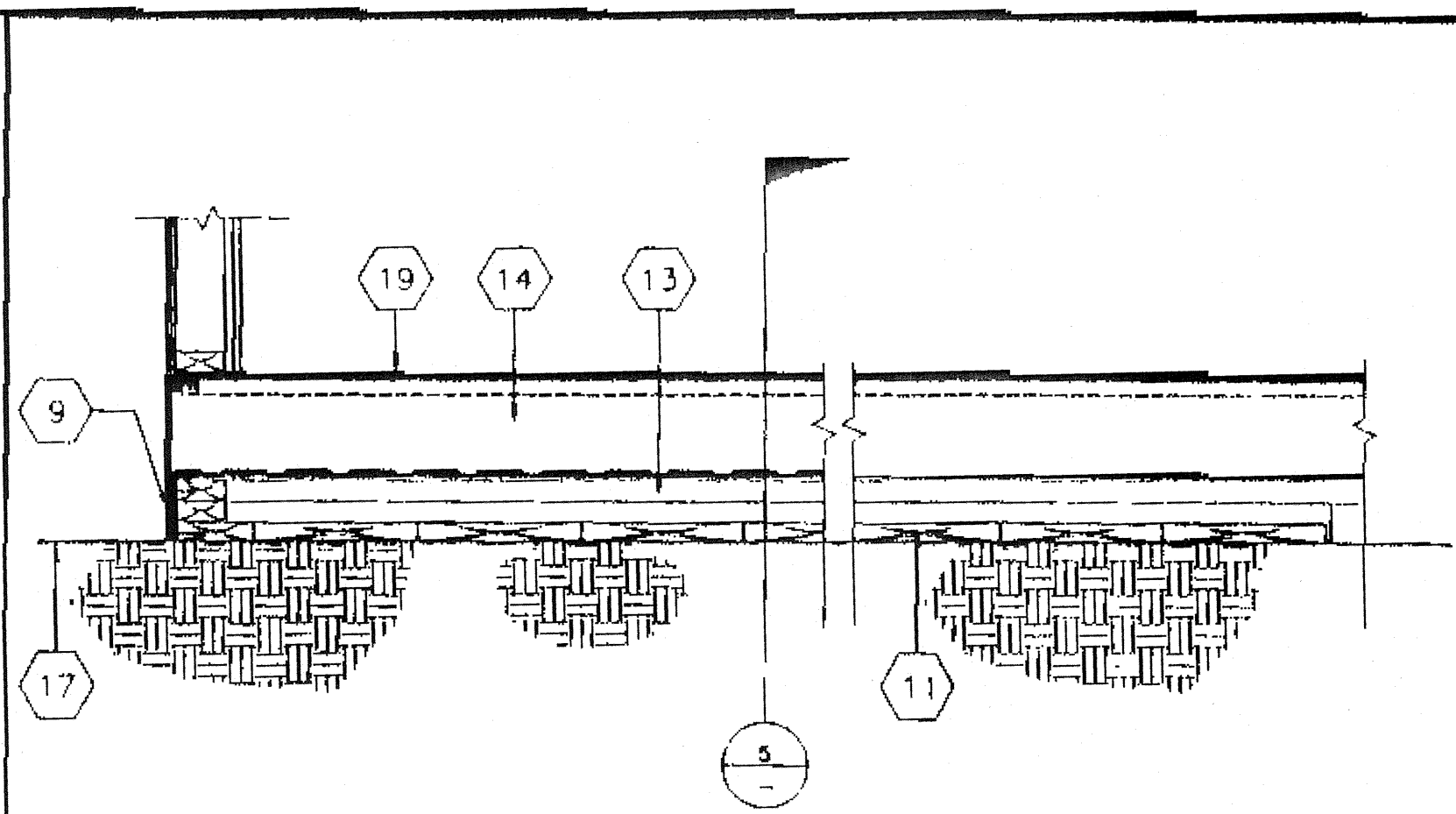

6 SCALE: 1 1/2"=1'-0"  
MODLINE PAD @ END WALL

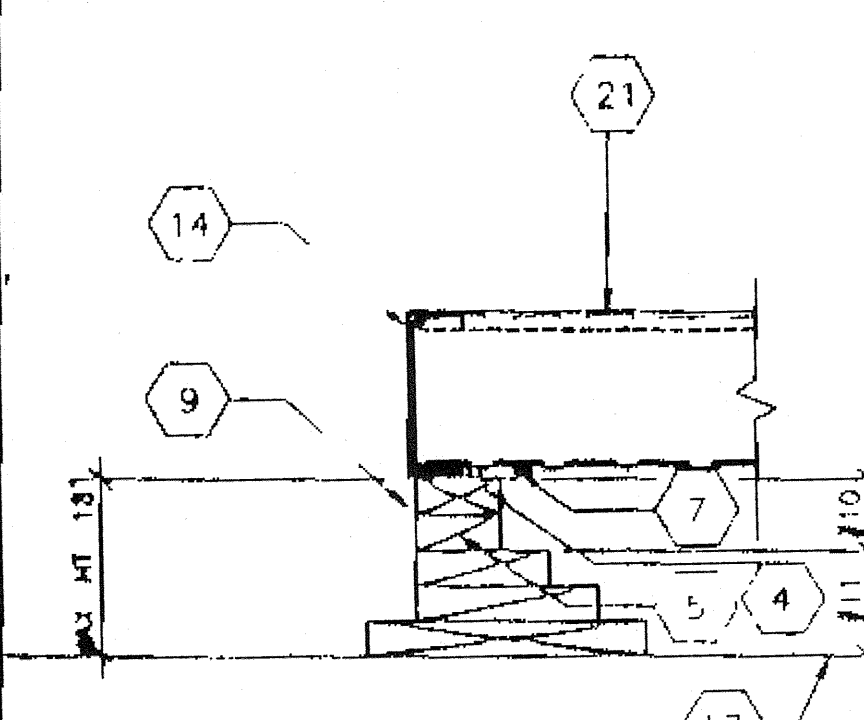

10 SCALE: 1 1/2"=1'-0"  
ADD BLK'S/SHIMS TO LEVEL FOUND.

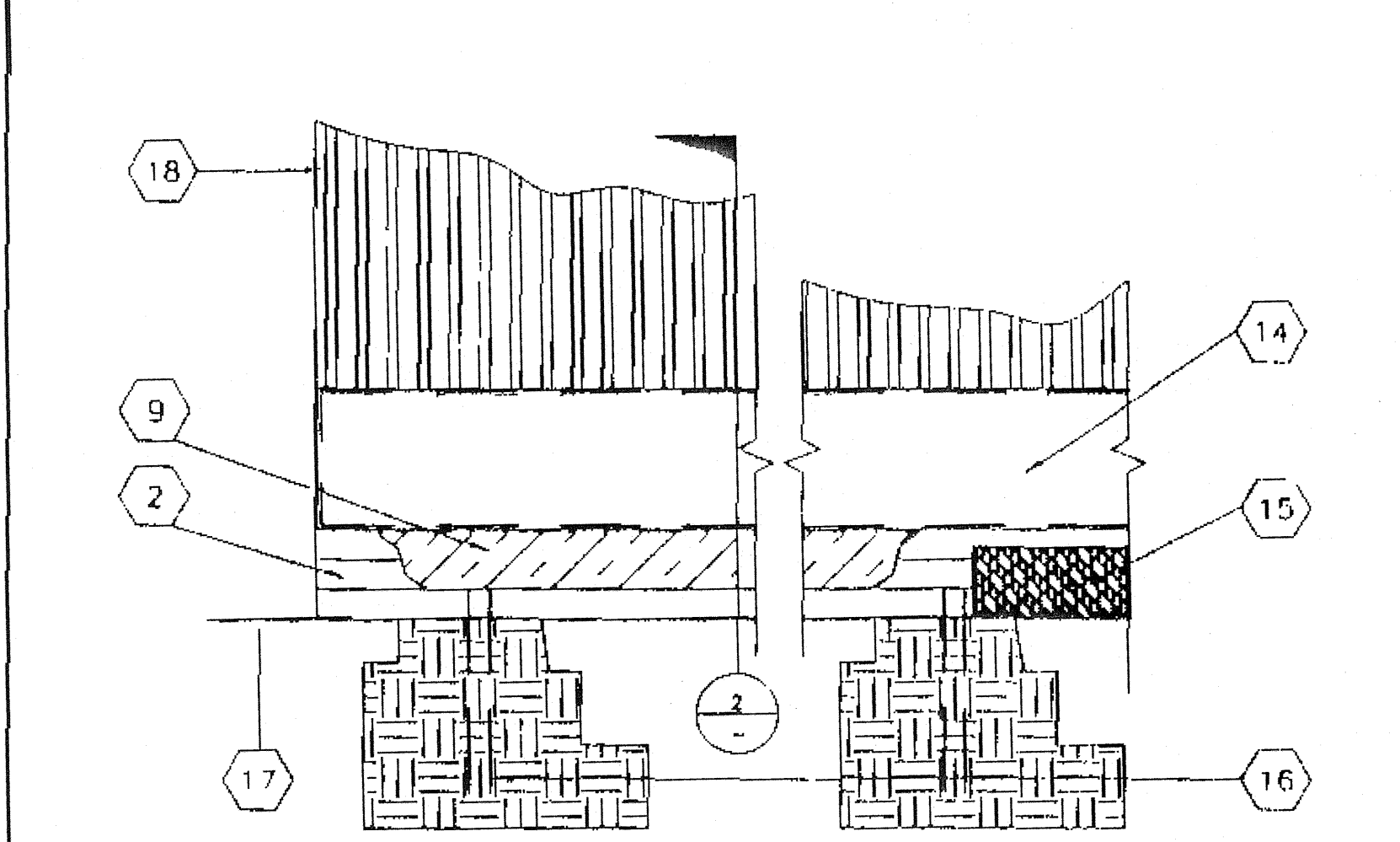

7 SCALE: 1 1/2"=1'-0"  
FOUNDATION ELEVATION @ SIDE WALL

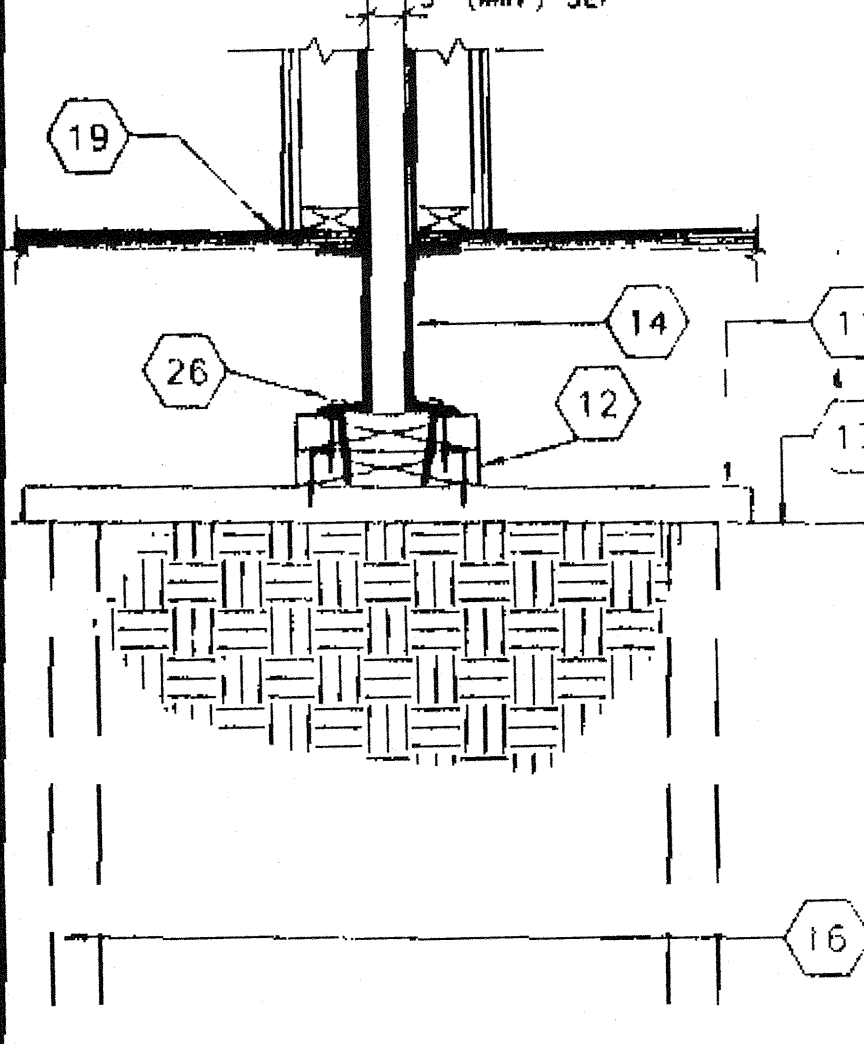

11 SCALE: 1 1/2"=1'-0"  
FOUND. AT ADJ. BLDG

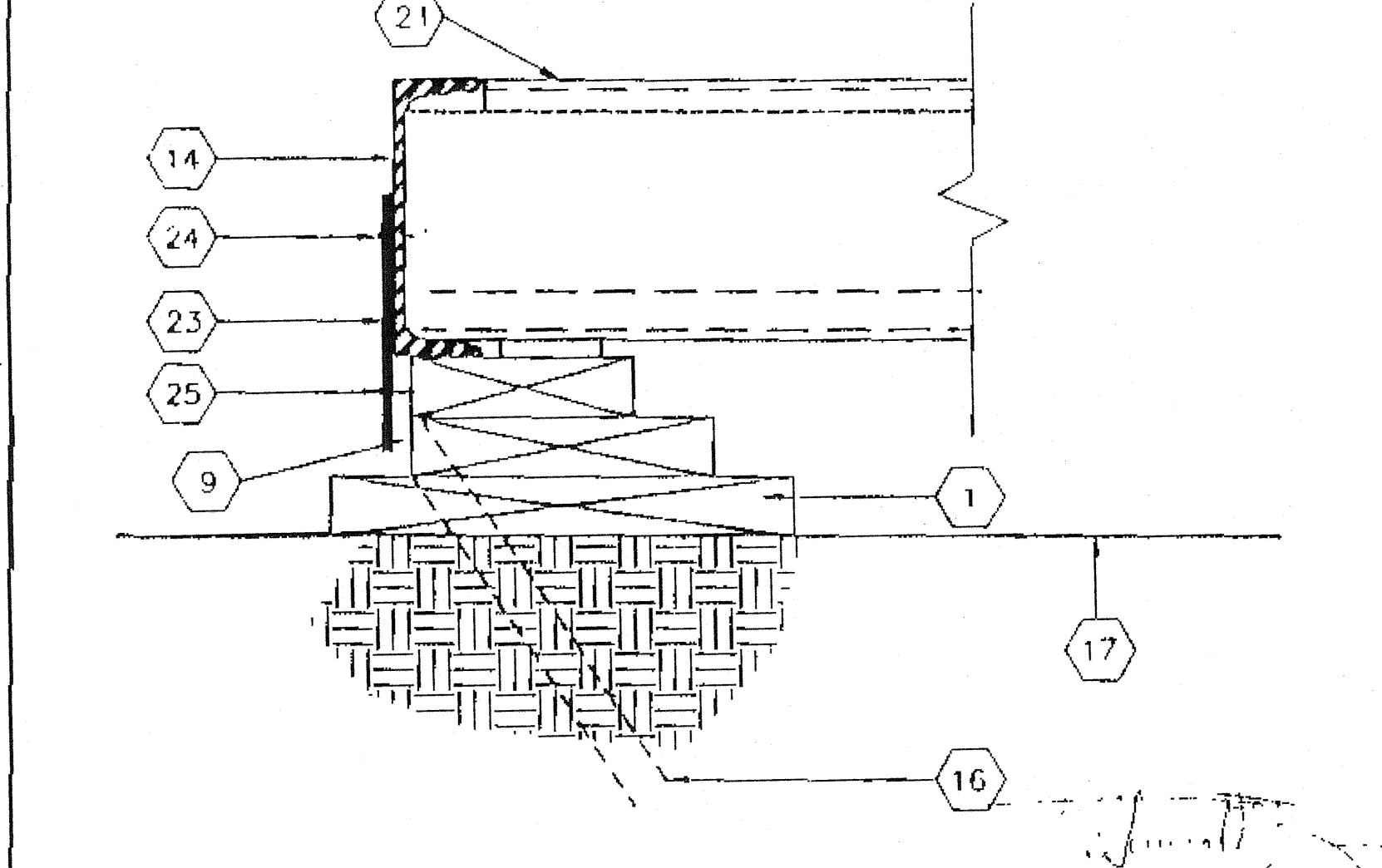

8 SCALE: 3"=1'-0"  
TYPICAL TIE PLATE

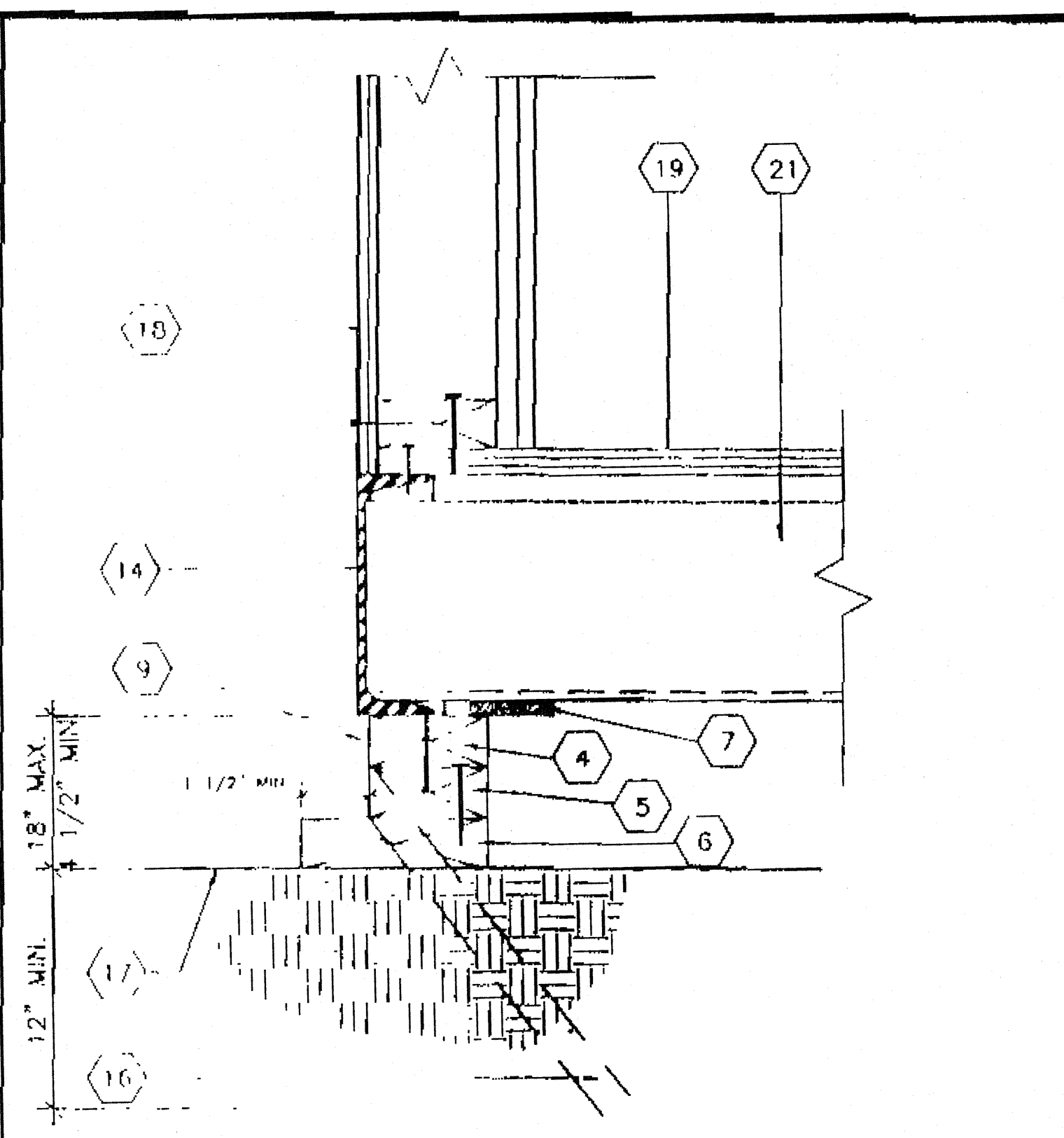

3 SCALE: 3"=1'-0"  
FOUNDATION @ END WALL

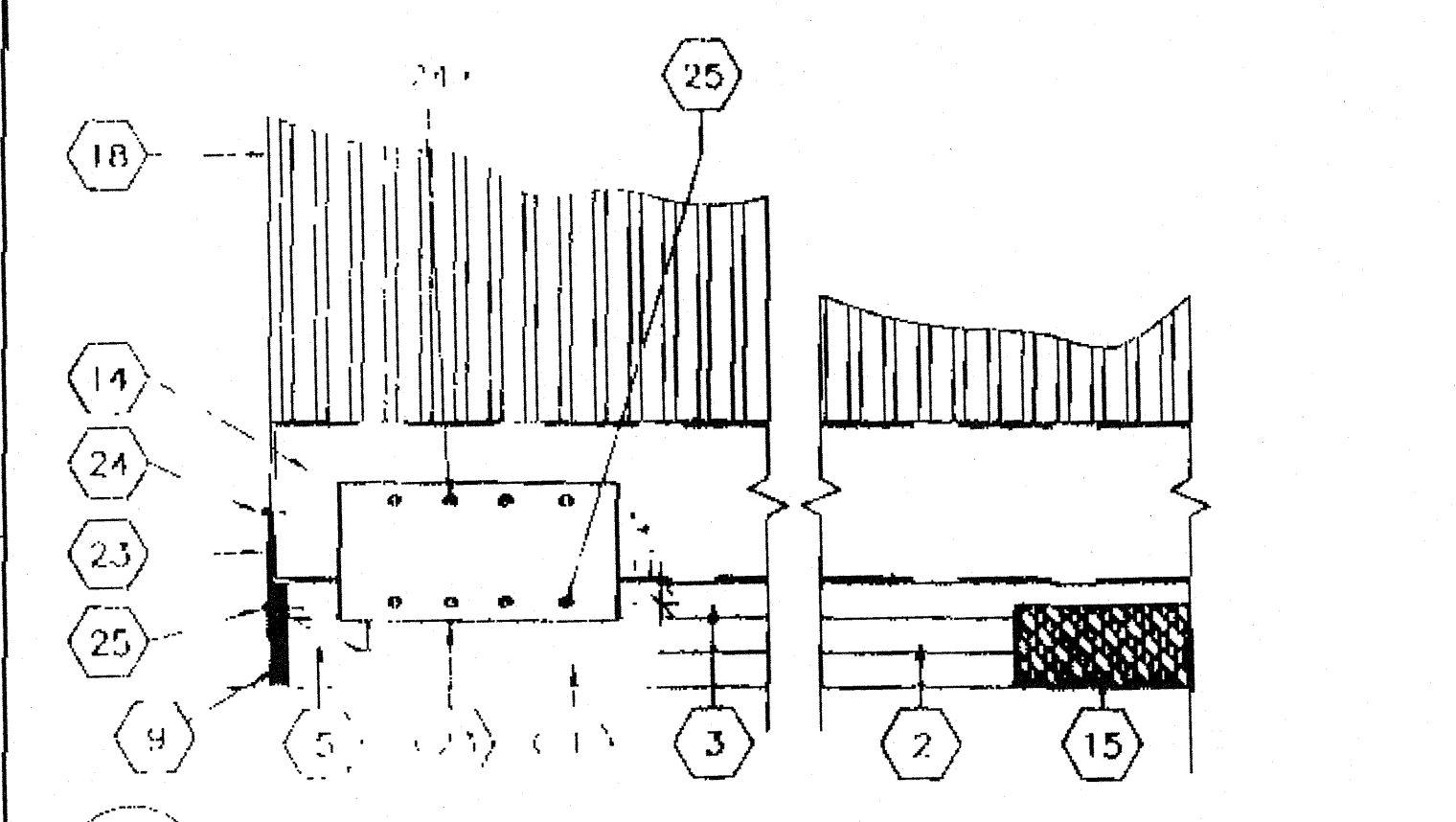

4 SCALE: 1 1/2"=1'-0"  
DETAIL @ FOUNDATION CORNER

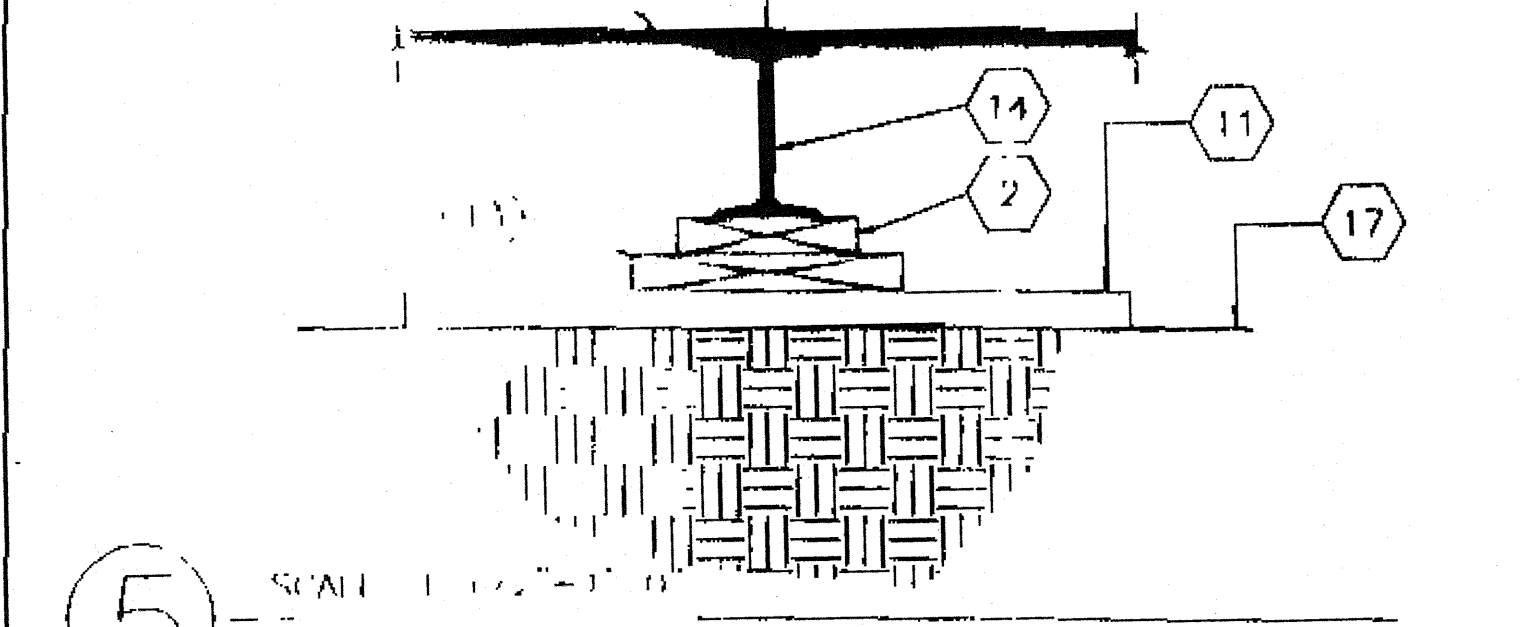

5 SCALE: 1 1/2"=1'-0"  
FOUNDATION PAD @ MODLINE

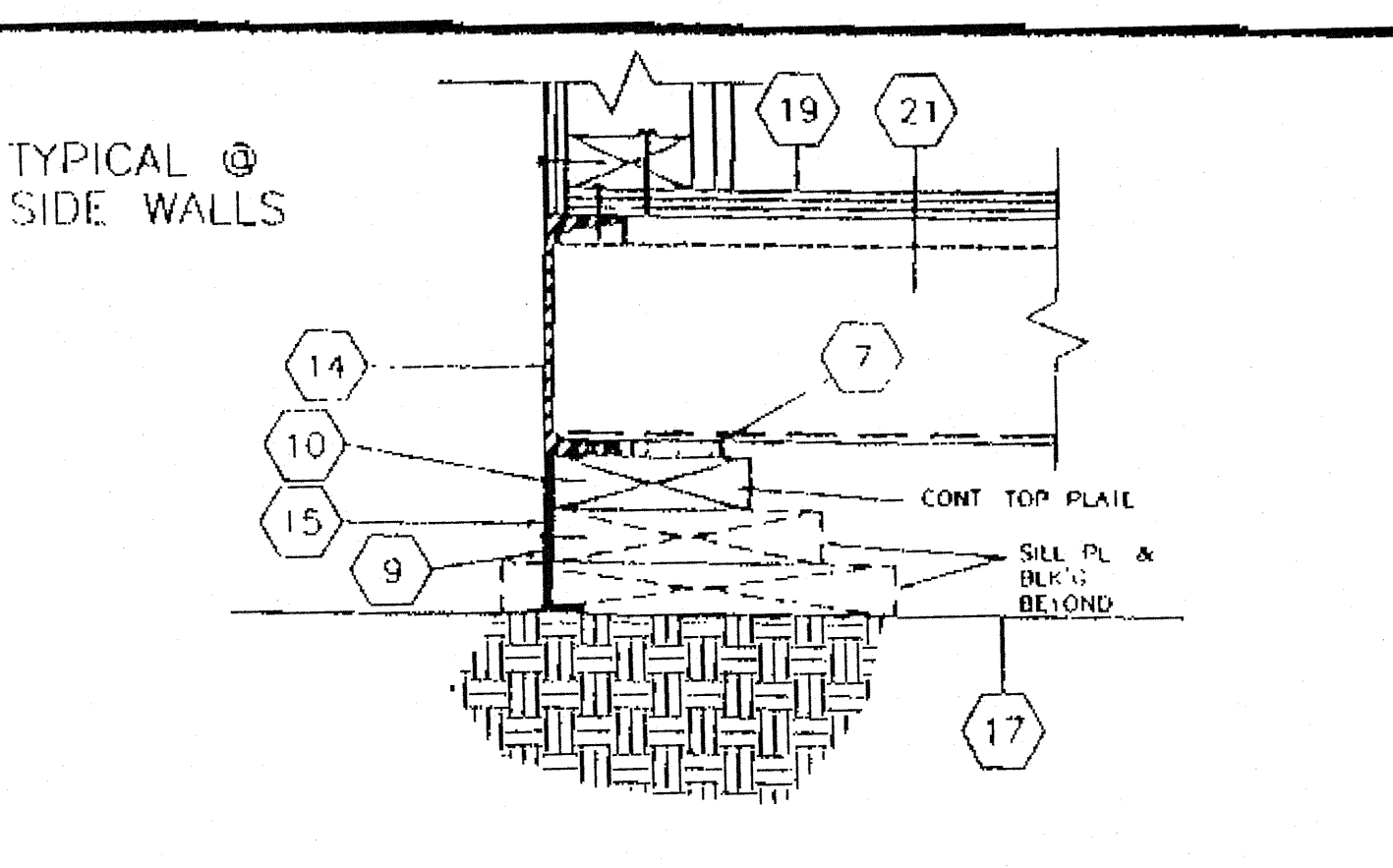

1 SCALE: NTS  
FOUNDATION VENT

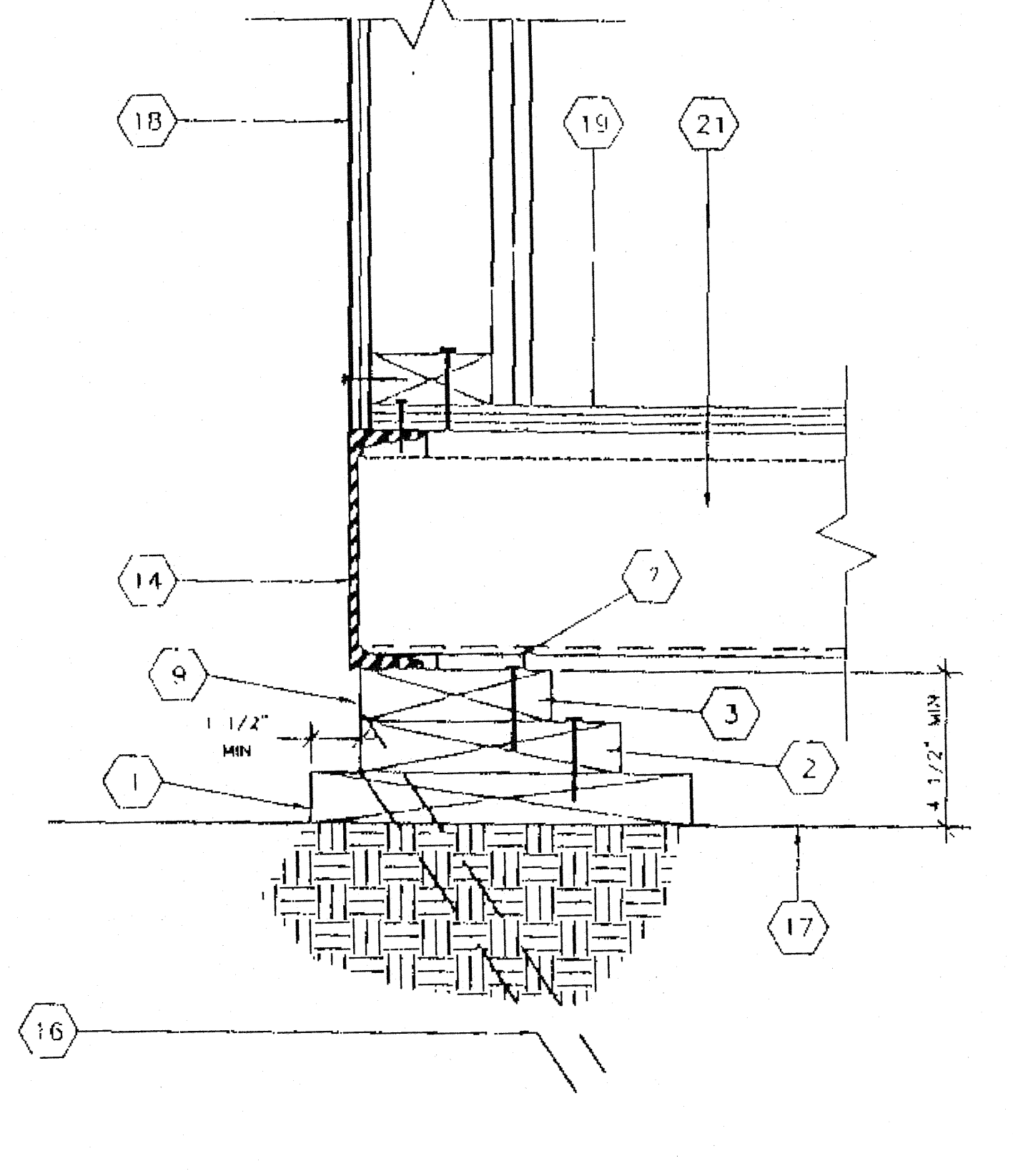

2 SCALE: 3"=1'-0"  
FOUNDATION @ SIDE WALL

**KEY NOTES**

- 1 2X12 SILL PLATE SEE FOUND. PLAN FOR LENGTH
- 2 2X8 BLOCKING W/16d @ MAX 5" O.C. TO SILL PLATE
- 3 2X6 TOP PLATE W/16d @ MAX 5" O.C. TYP BLOCKING
- 4 2X4 TOP PLATE W/16d @ MAX 5" O.C. TO BLOCKING
- 5 2X4 BLOCKING W/16d MAX 5" O.C. TO SILL PLATE
- 6 2X6 SILL PLATE SEE FOUND. PLAN FOR LENGTH
- 7 5/8"x2 1/2" SHIM (WHEN REQ)
- 8 INSERT REQ'D 2X4 BLK'NG OR PLYWD. SHIM W/16d @ 12" O.C. FACE NAIL
- 9 OPTIONAL - MIN. 3/8" PLYWOOD SHIRTING W/ 10d @ MIN. 4" O.C. @ ENDWALLS & 6" O.C. @ SIDEWALLS E.N. & TYP. 12" O.C. FN. PLATE TO PLATE NAILING FOR THE FOUNDATION MEMBERS CAN BE DECREASED TO 12" O.C. AND FOUNDATION BLOCKING SHALL BE RECESSED SUCH THAT THE SHIRTING SHALL BE INSTALLED FLUSH WITH THE PERIMETER FLOOR CHANNEL.
- 10 10d GALV NAIL @ MAX. 4" O.C
- 11 2X12x2'-6" SILL PLATE SEE FOUND. PLAN FOR QUANTITY REQ'D
- 12 2 X 10 PLATES W/ 2-16D BOX @ 6" O.C.
- 13 2X10 BLK'NG FACE OR TOE NAIL 16d @ MAX 12" O.C. ADD BLKS. OR SHIMS AS REQ'D
- 14 FLOOR FRAME BEAM SEE STRUCTURAL
- 15 TYPICAL FOUNDATION VENT (SEE FOUNDATION PLAN FOR SIZES AND LOCATIONS).
- 16 SILL RESTRAINT 1" @ PIPE SEE FOUND FOR LOCATION
- 17 FINISH GRADE
- 18 EXTERIOR FINISH
- 19 PLYWOOD SUBFLOOR
- 20 MOD-LINE
- 21 FLOOR-JOIST
- 22 4"x12"x10 GA. PLATE
- 23 6"x12"x10 GA. PLATE
- 24 1 4" @ S.T.S. TYP. 4-PLACES
- 25 1 4" @ X3" LG. LAG SCREW TYP. 4-PLACES
- 26 5, 8" @X4" LAGS (FOR LOCATION SEE PLAN)

FOUNDATION LUMBER TO BE PRECUT AT FACTORY, LUMBER GRADES & PRESSURE TREATING TO BE VERIFIED BY IMPLANT INSPECTOR

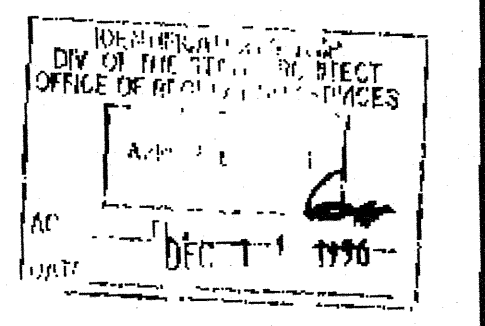

REVISIONS

ELECTRICAL

MECHANICAL

STRUCTURAL

ARCHITECT

DIVISION OF THE STATE ARCHITECT  
**REVISED**  
 DIVISION OF THE STATE ARCHITECT  
 19775  
 2-19-96

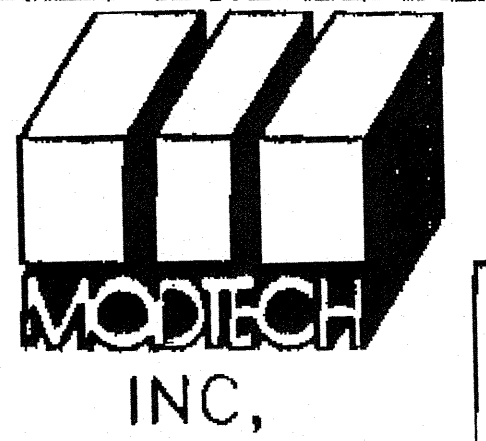

MODTECH INC.  
 2830 BARRETT AVE  
 PERRIS, CA. 92512  
 PH. (909) 943-4014  
 FX. (909) 940-0427

JOB NO.  
 IDENTIFICATION STAMP  
 DIV OF THE STATE ARCHITECT  
 APPROX 15690  
 DATE 7/24/96

DRAWN BY  
 DATE  
 CHECKED BY  
 DATE  
**F3.0**

CONFIDENTIAL - THIS DOCUMENT AND THE INFORMATION CONTAINED HEREIN ARE THE PROPERTY OF MODTECH INC. UNAUTHORIZED COPYING, DISCLOSURE, OR OTHER UNAUTHORIZED USES ARE PROHIBITED.

**FOUNDATION DETAILS**

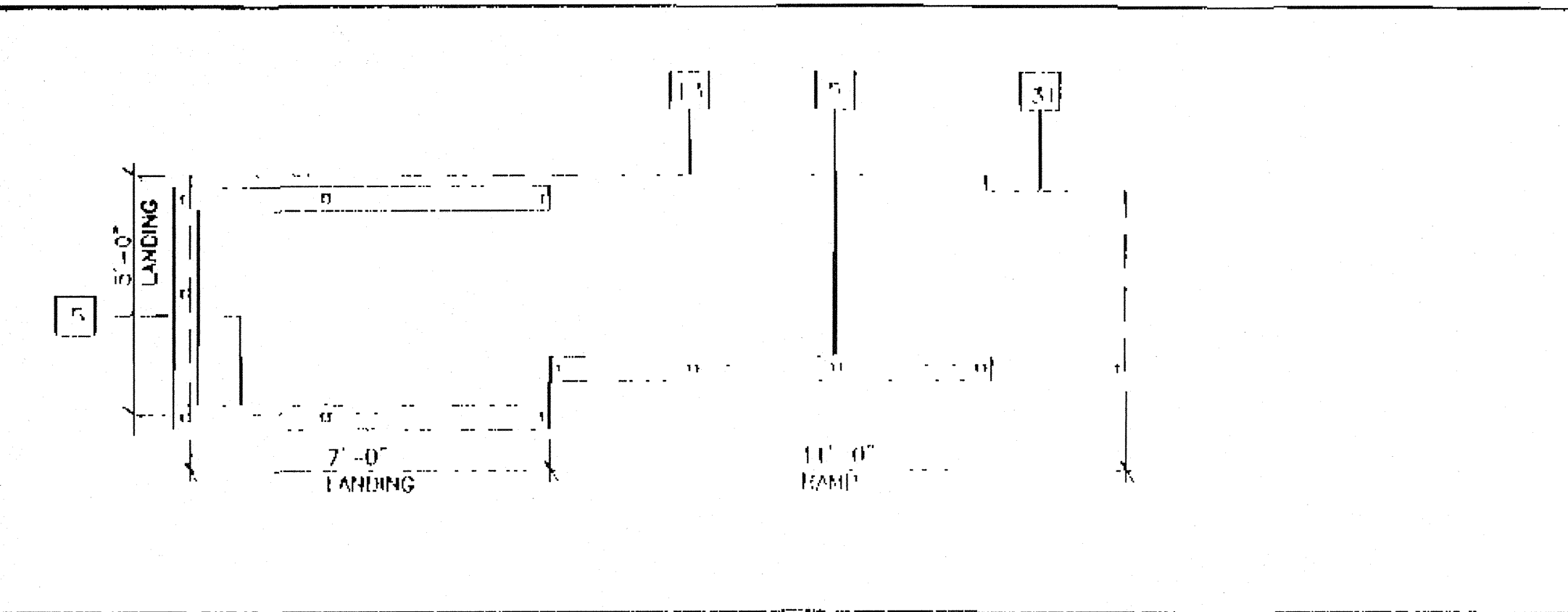
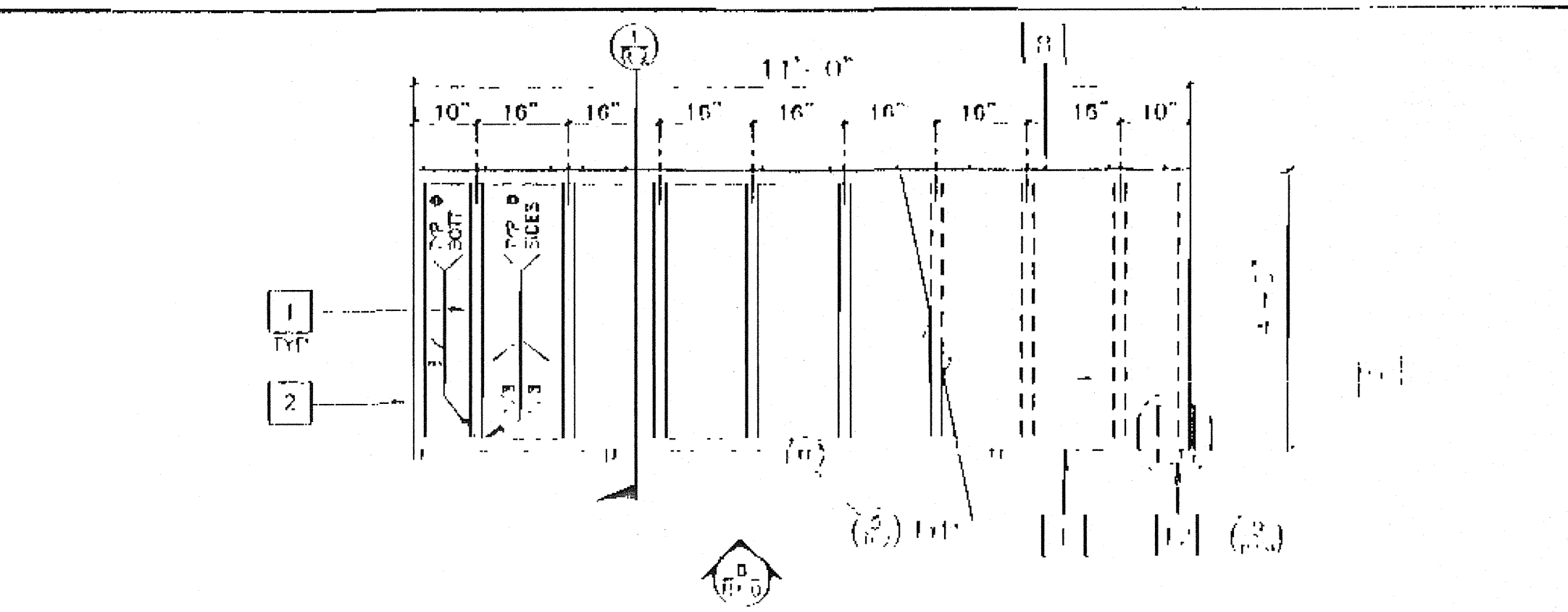
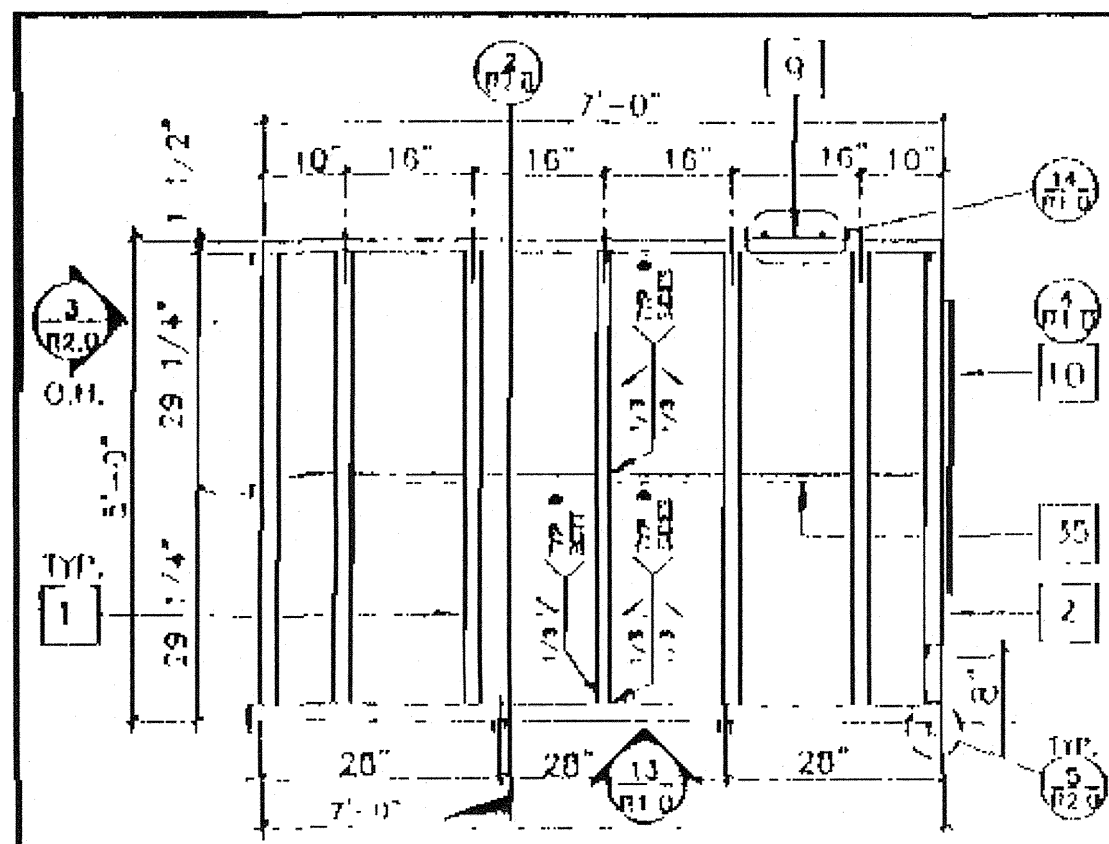

**KEY NOTES**

- 1 TS 2" x 2" x 14ga
- 2 TS 1 1/2" x 1 1/2" x 14ga (Fy = 39KSI)
- 4 TS 1" x 1" x 16ga WHEELCHAIR GUIDE
- 5 2 x 6 PL SILL PLATE
- 6 6" x 10ga CONT. PLATE W/ 1/4" x 2" TEK SCREWS @ 9" OC INTO WOOD OR FOUND. BLOCKS OR #14 x 2" TEK SCREWS INTO STEEL @ 9" OC
- 9 6" x 12" x 10ga PLATE W/ 2-1/4" x 3" LAGS TO STRUCTURAL FRAME OF BUILDING
- 10 3" x 1" x 3'-0" x 10ga BENT PLATE
- 11 2" x 4" x 12ga BASE PLATE W/ 2-1/4" x 1" LAGS
- 12 6" x 10" x 12ga BASE PLATE @ RAMP TOP
- 13 LINE OF RAMP/LANDING ABOVE
- 14 LOWER LANDING BY DISTRICT
- 15 SKINNING: PLYWOOD TO MATCH BUILDING SIDING. BLOCK ALL JOINTS. ATTACH W/ 7d @ 6" OC EDGES AND 12" OC FIELD. AT EDGE CONNECTION TO T.S. USE #14 x 2" TEK SCREWS @ 6" OC
- 16 12ga METAL DECK: NON-SLIP SURFACE. DESIGN COEFFICIENT OF FRICTION GREATER THAN 0.6. MAINTAINABLE FOR 1 YR.
- 17 RAMP EXTENSION FRAME.
- 18 EXISTING BUILDING.
- 27 RAMP BY MODTECH
- 28 FLUSH TRANSITION
- 31 NOTCH BOTTOM PLATE (MUD SILL) AS REQUIRED TO CLEAR RAMP TOP. MAX NOTCH 1 1/2" x 4'-0" LONG.
- 35 TS 1" x 1" x 10ga

LANDING FRAME 12

RAMP FRAME 7

SILL PLAN FOR RAMP AND LANDING 1

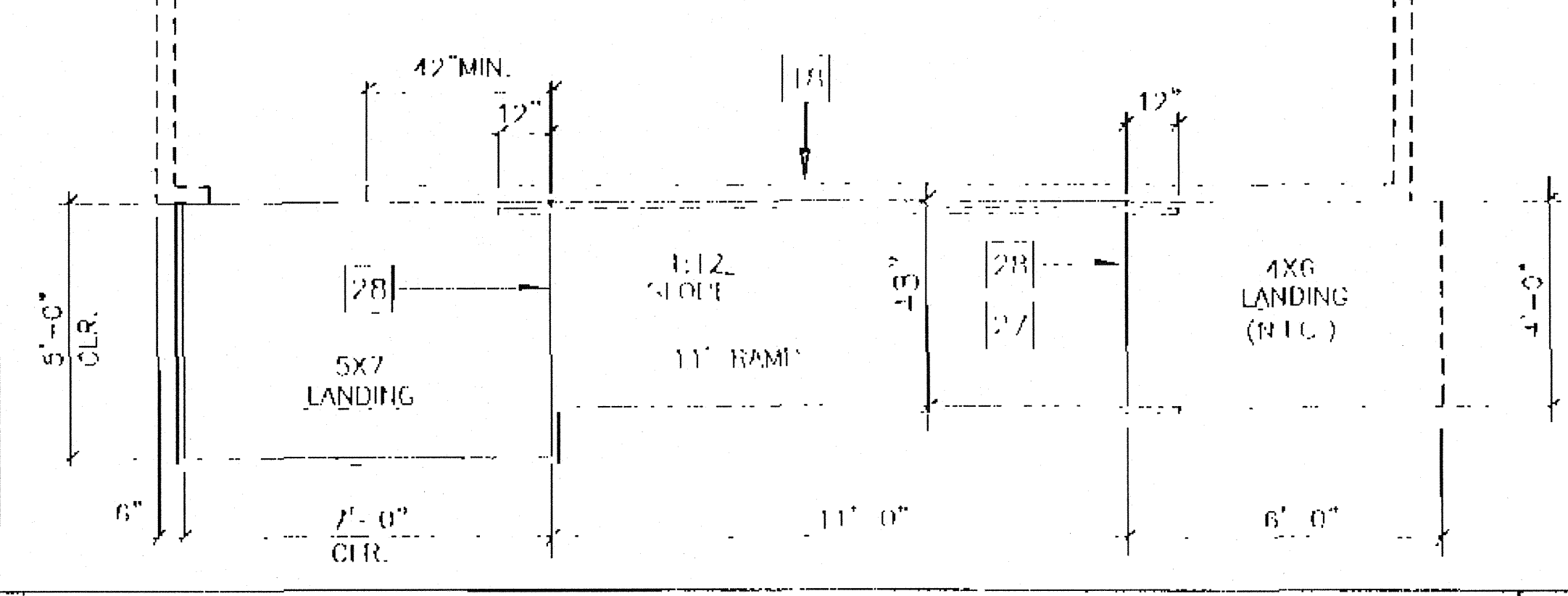
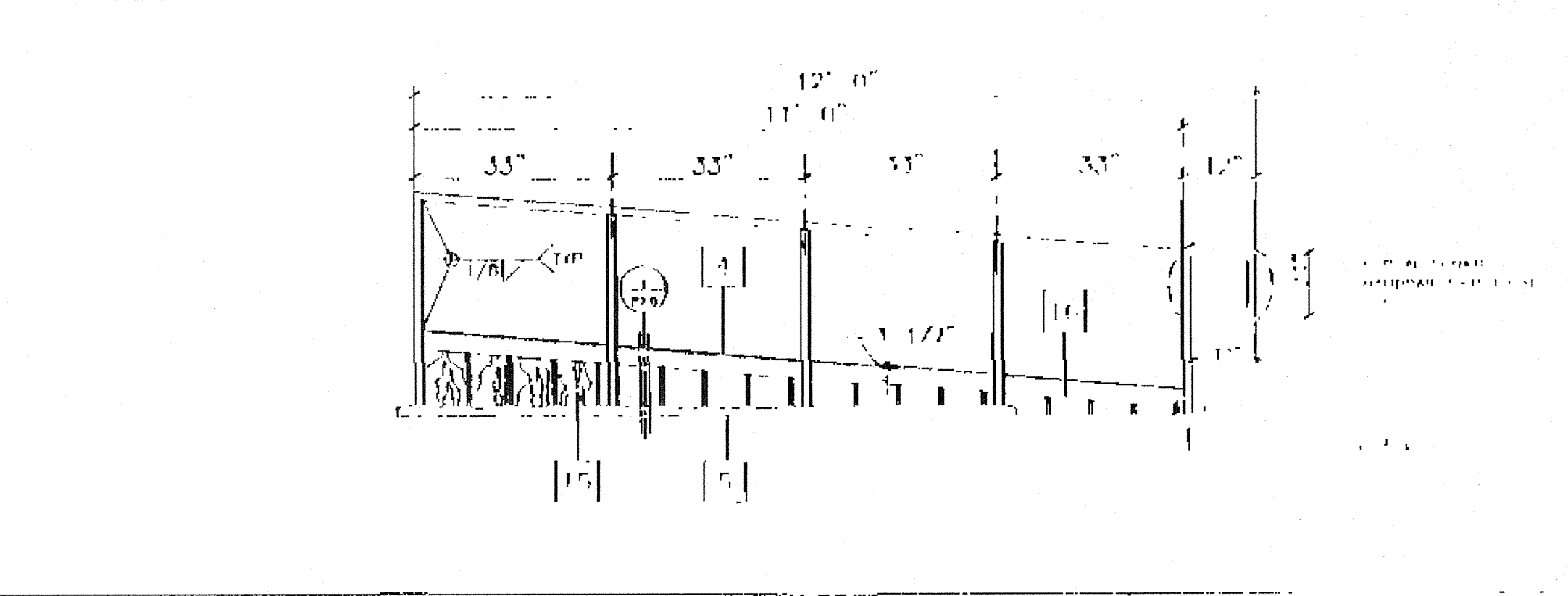
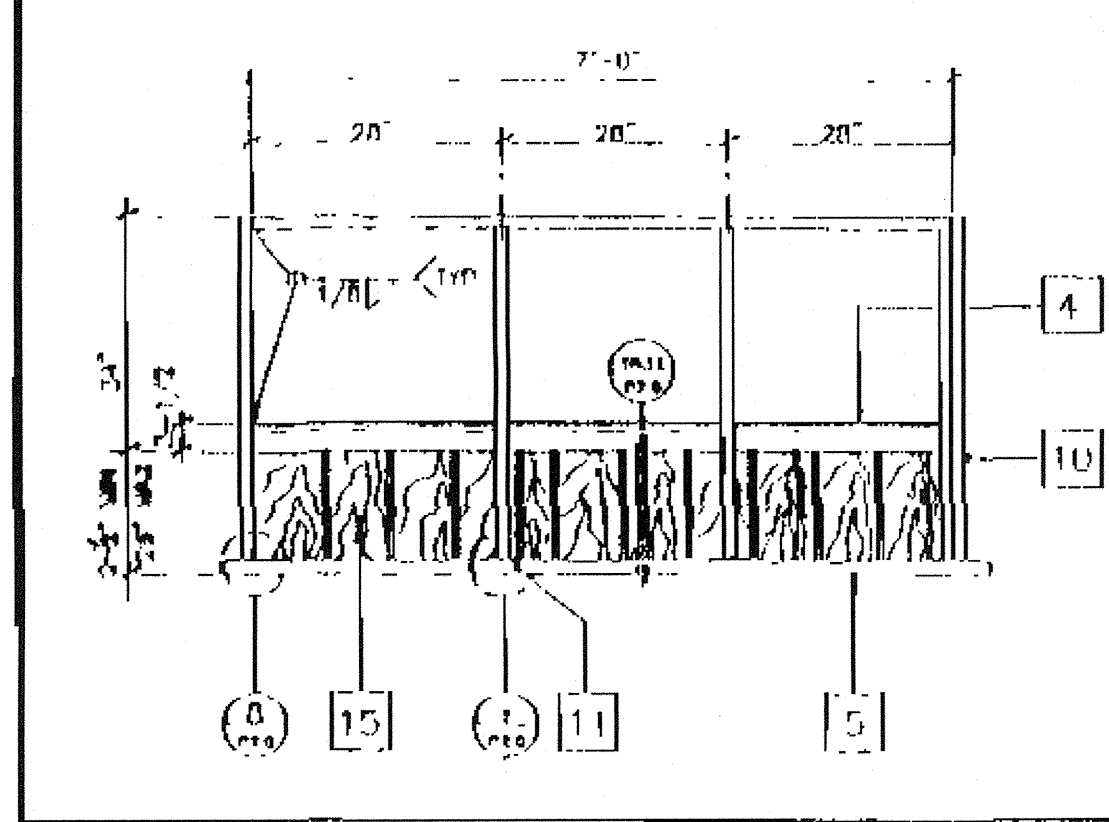

LANDING ELEVATION 13

RAMP ELEVATION 8

RAMP AND LANDING AT BUILDING 2

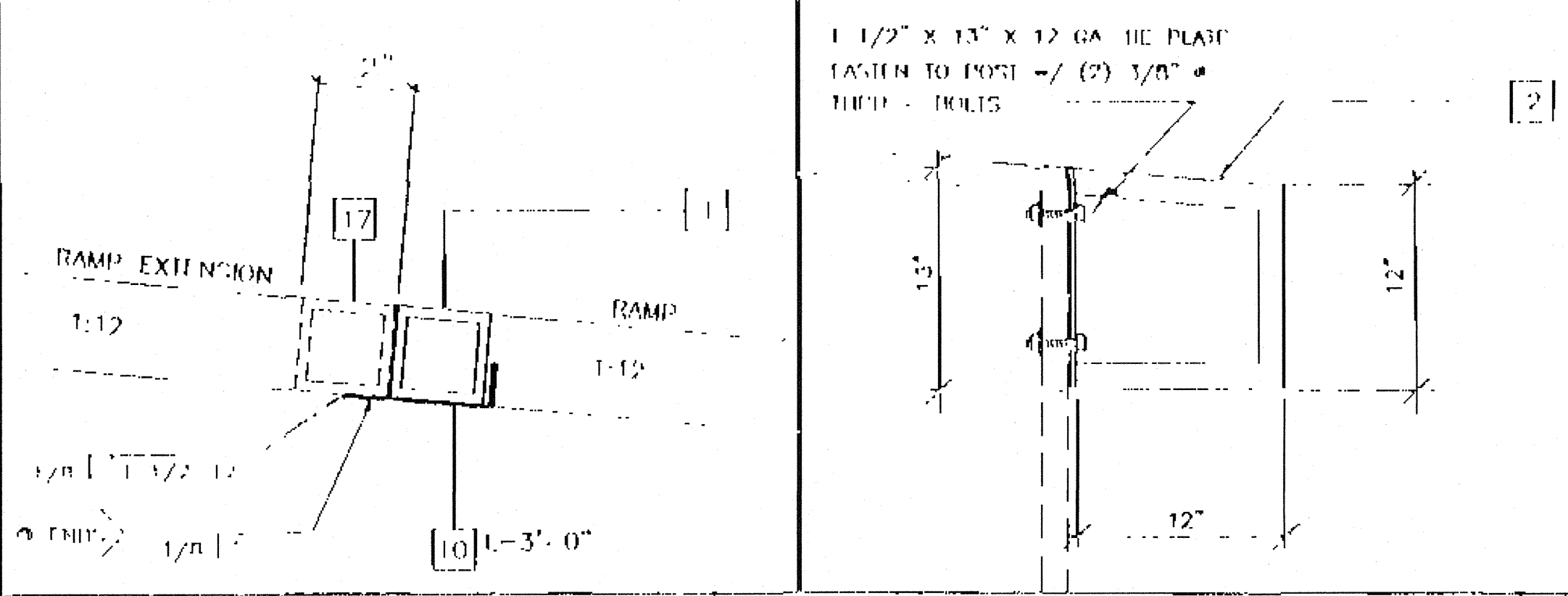
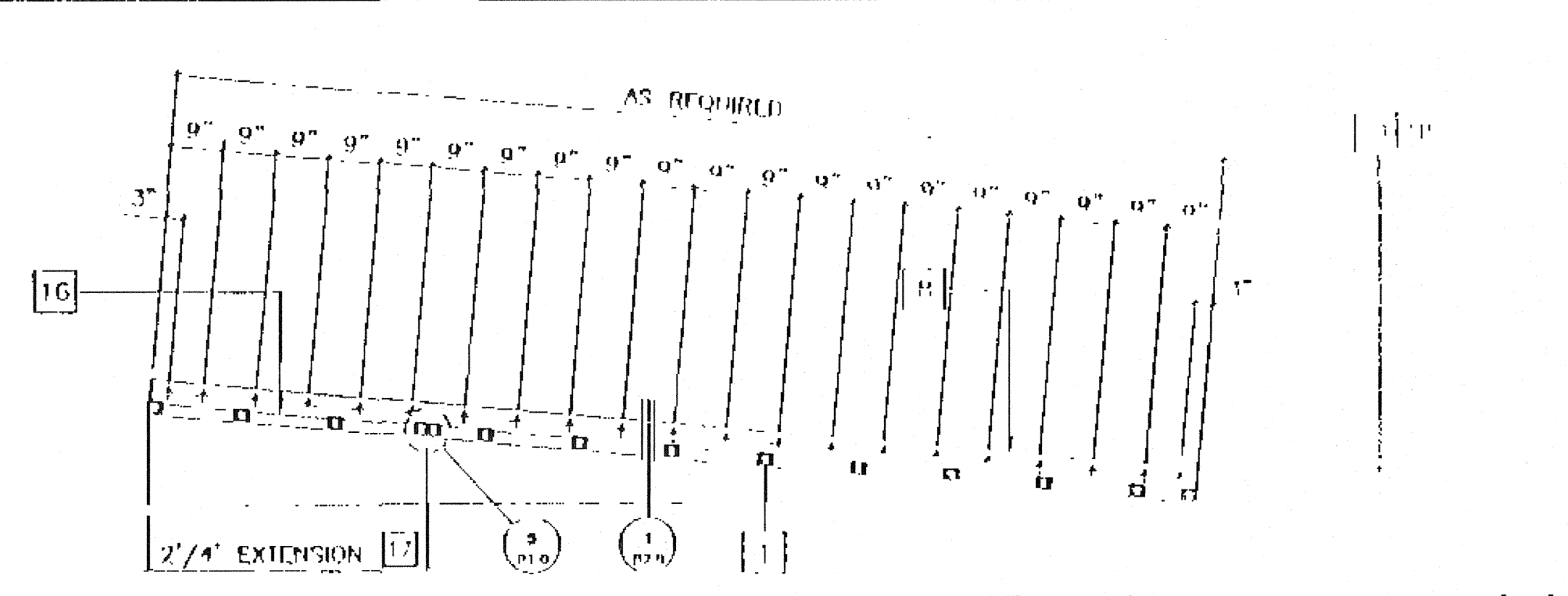
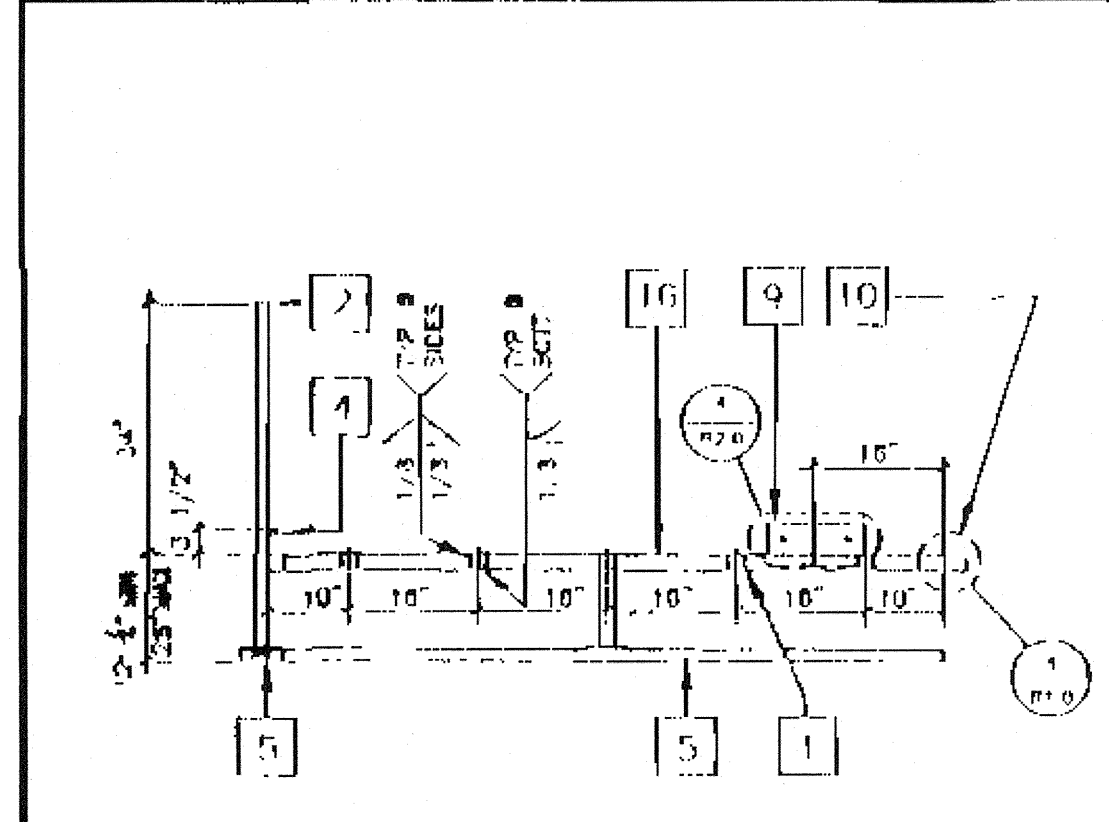

LONG. SECTION @ LANDING 14

LONGITUDINAL SECTION @ RAMP 9

RAMP EXTENSION TO RAMP 5

GUARD RAIL EXTENSION 3

**NOTES**

- 1 RAMP: RAMP SHALL NOT SLOPE MORE THAN 1" IN 12"
- 2 HANDRAILS: HANDRAILS AT BOTH SIDES OF RAMP AT 34" HT.
- 3 SURFACE: LANDING & RAMP TO HAVE NON-SLIP SURFACE. AMCOR GRIP II AS MANUFACTURED BY AMERICAN CHEMICAL COMPANY (OR EQUAL)
- 4 GROUNDING: PROVIDE GROUNDING OF RAMP TO IRON FRAME W/ #10 CU TO BOTH GROUND LUGS.
- 5 ARCHITECT SITE / RAMP / LANDING PLANNING: DUE TO VARYING SITE CONDITIONS THE MAXIMUM HEIGHT OF FINISH FLOOR FROM GRADE IS 28". THEREFORE IT IS POSSIBLE THAT THE ACCESS RAMP ATTACHED TO THE BUILDING COULD BE 20'-0" AT A SLOPE OF 1:12 ARCHITECT MUST TAKE INTO ACCOUNT THAT THE RAMP SUPPLIED BY MODTECH INC. IS 11'-0" AT A SLOPE OF 1:12 THEREFORE THE ARCHITECT WILL HAVE TO DESIGN AND PROVIDE SUFFICIENT DETAILS OF RAMP EXTENSIONS AND BOTTOM LANDING DEPENDING ON PARTICULAR SITE CONDITIONS. IN NO WAY IS MODTECH INC. RESPONSIBLE FOR ANY RAMP EXTENSION EXCEEDING THE ORIGINAL PLAN AS SHOWN ON SHEET R-1.
- 6 ALL 1 1/4" AND 1 1/2" TUBE SIZES TO BE OF ASTM A500 GRADE A STEEL (Fy = 39 KSI)

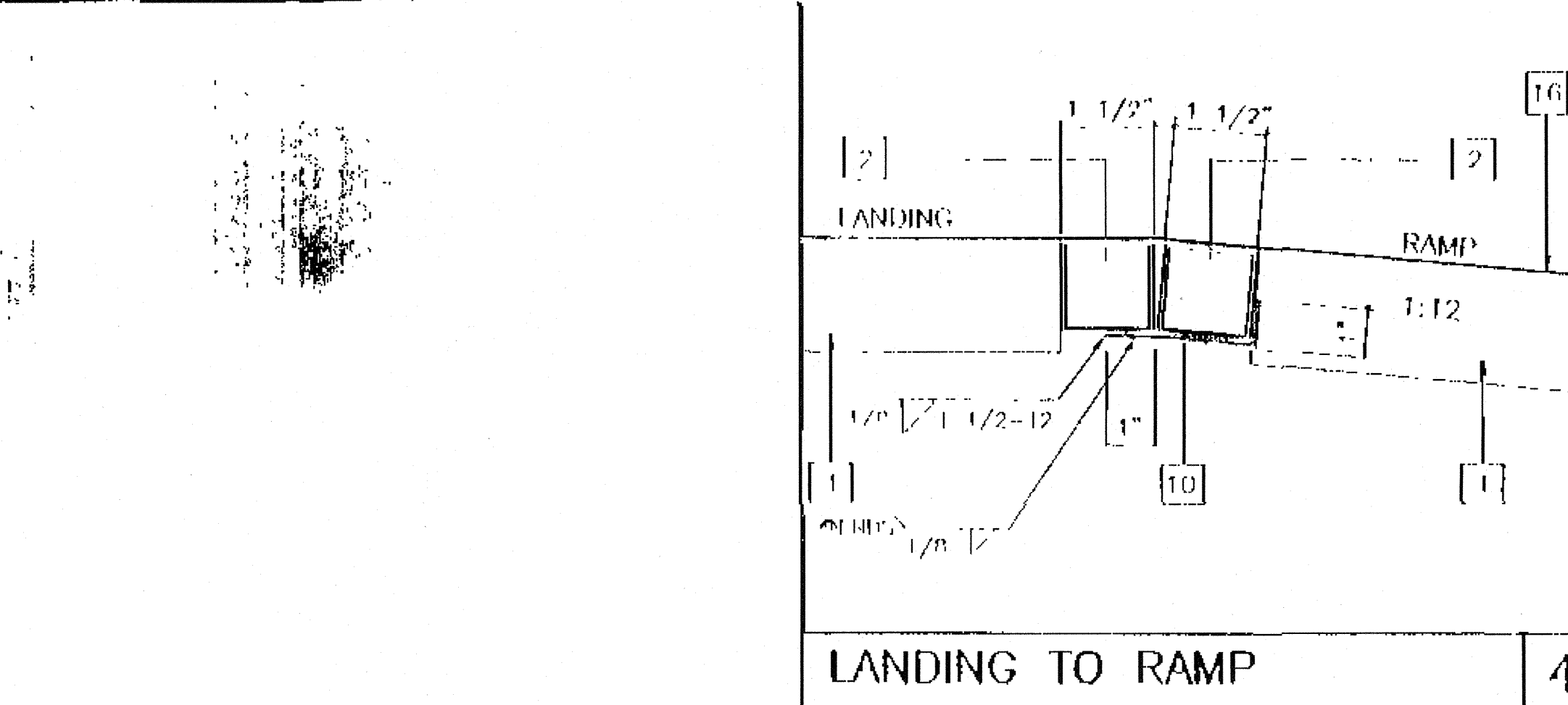
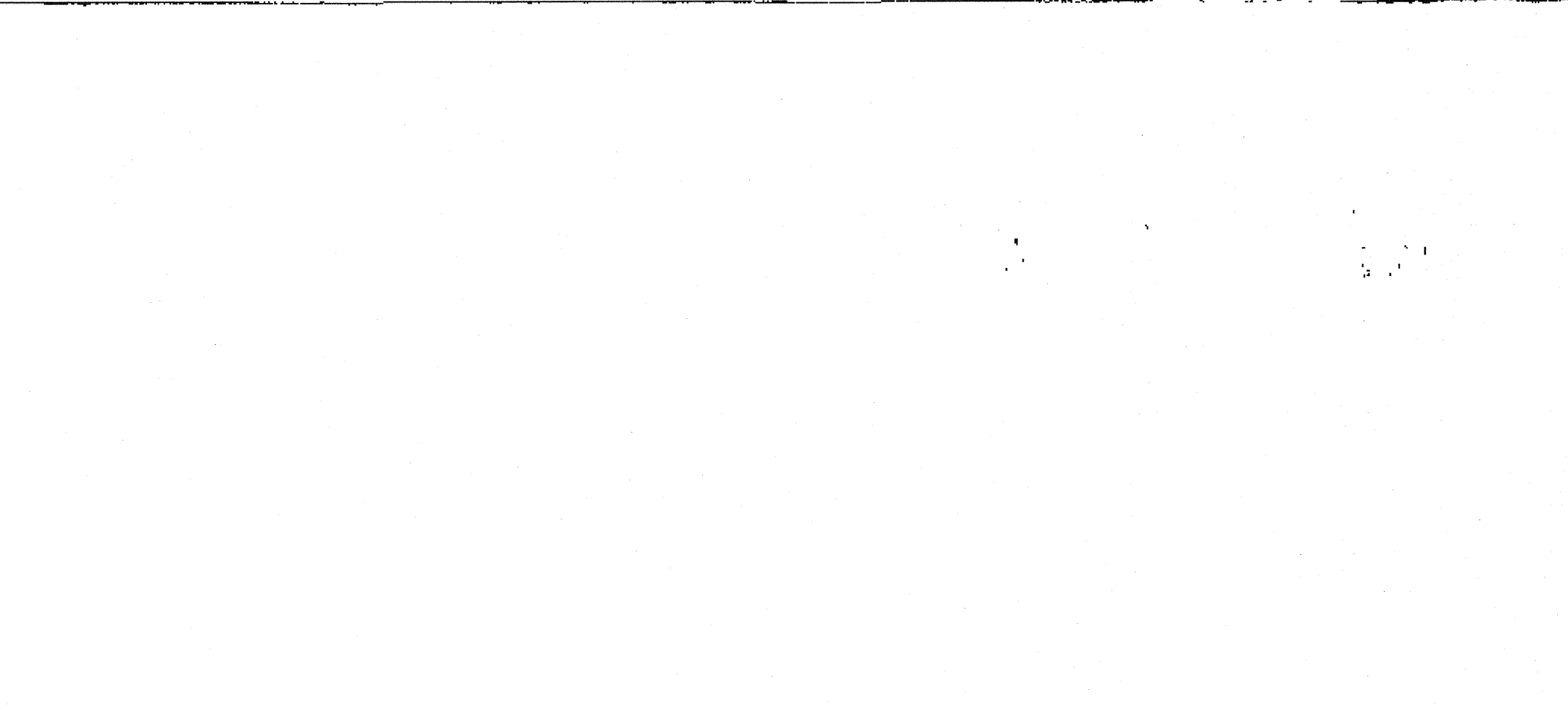

**REVISIONS**



Electrical Engineer's Seal

Mechanical Engineer's Seal

Structural Engineer's Seal

Architect's Seal

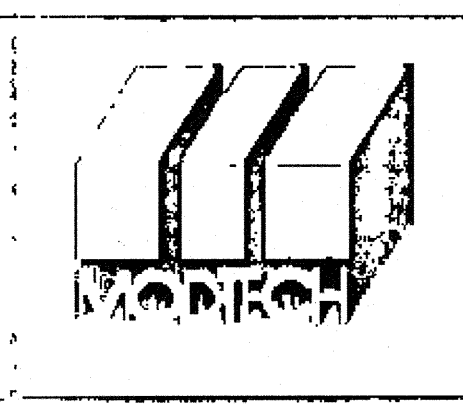
PC 275  
REVISED



**MODTECH INC.**  
2030 BARRETT AVENUE  
PERRIS, CALIF. 92572  
PH (909) 943-4014  
FAX (909) 940-0472

Job Number: PC 275  
© MODTECH INC. 1997  
DIV OF THE STATE ARCHITECT  
APPROX 110000  
AC PL SS TB  
DATE 7/24/14

drawn by: LVI  
date: 11/98  
checked by:  
project no.:  
MODTECH logo no.:  
**R1.0**

**RAMP / LANDING**



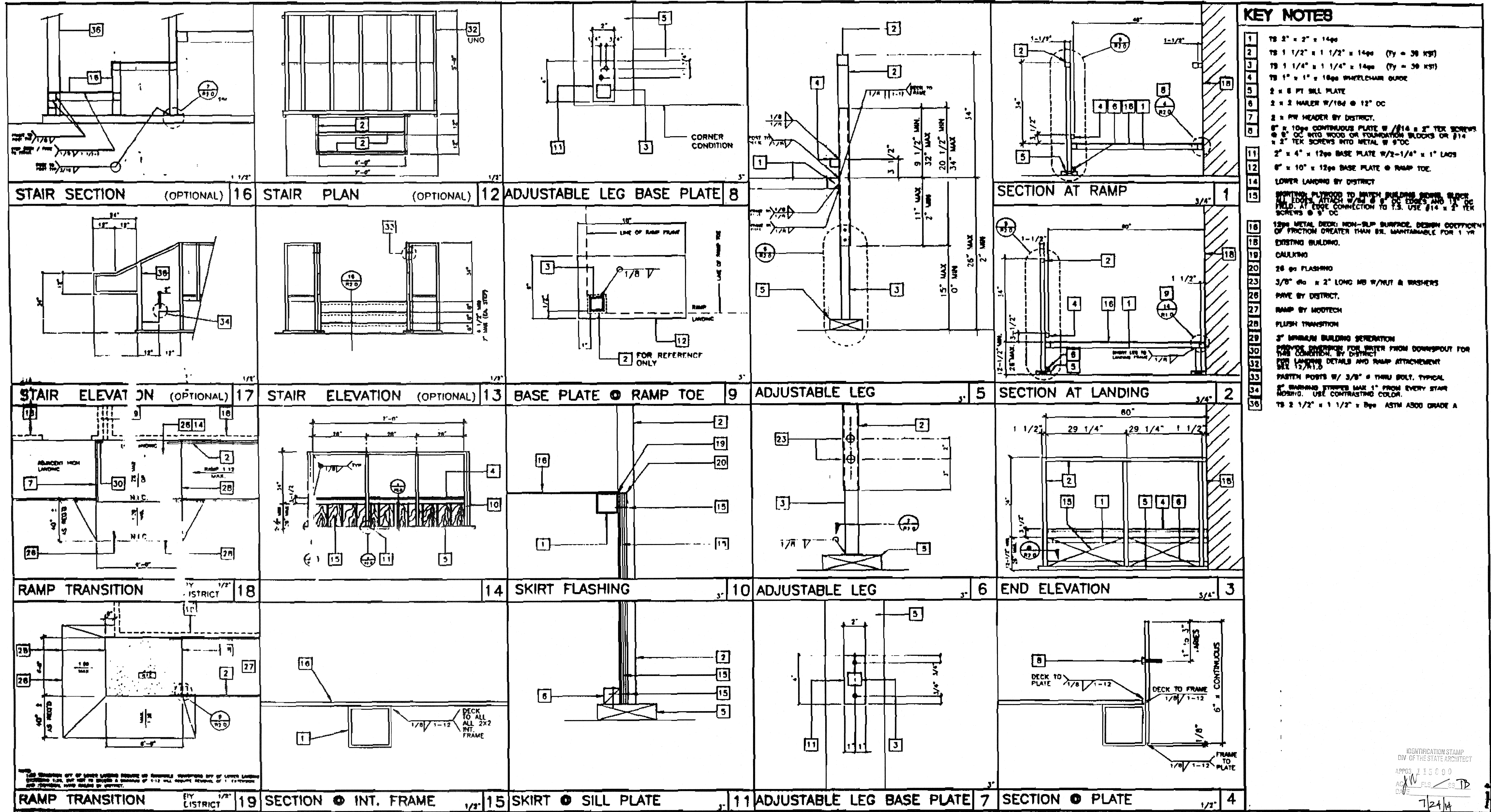

**REVISIONS**

NO.	DATE	DESCRIPTION

Professional Engineer's Seal  
Mechanical Engineer's Seal  
Structural Engineer's Seal  
Architect's Seal

IDENTIFICATION STAMP  
DIV. OF THE STATE ARCHITECT  
OFFICE OF REGULATION SERVICES  
PC 275  
DATE: JAN 21 1997  
REVISED

**MODTECH INC.**  
2830 BARRETT AVENUE  
PERRIS, CALIF. 92572  
PH: (909) 943-4014  
FAX: (909) 940-0427

Job Number: PC 275  
© MODTECH, INC. 1997

**RAMP/STAIR DETAILS**

**R2.0**

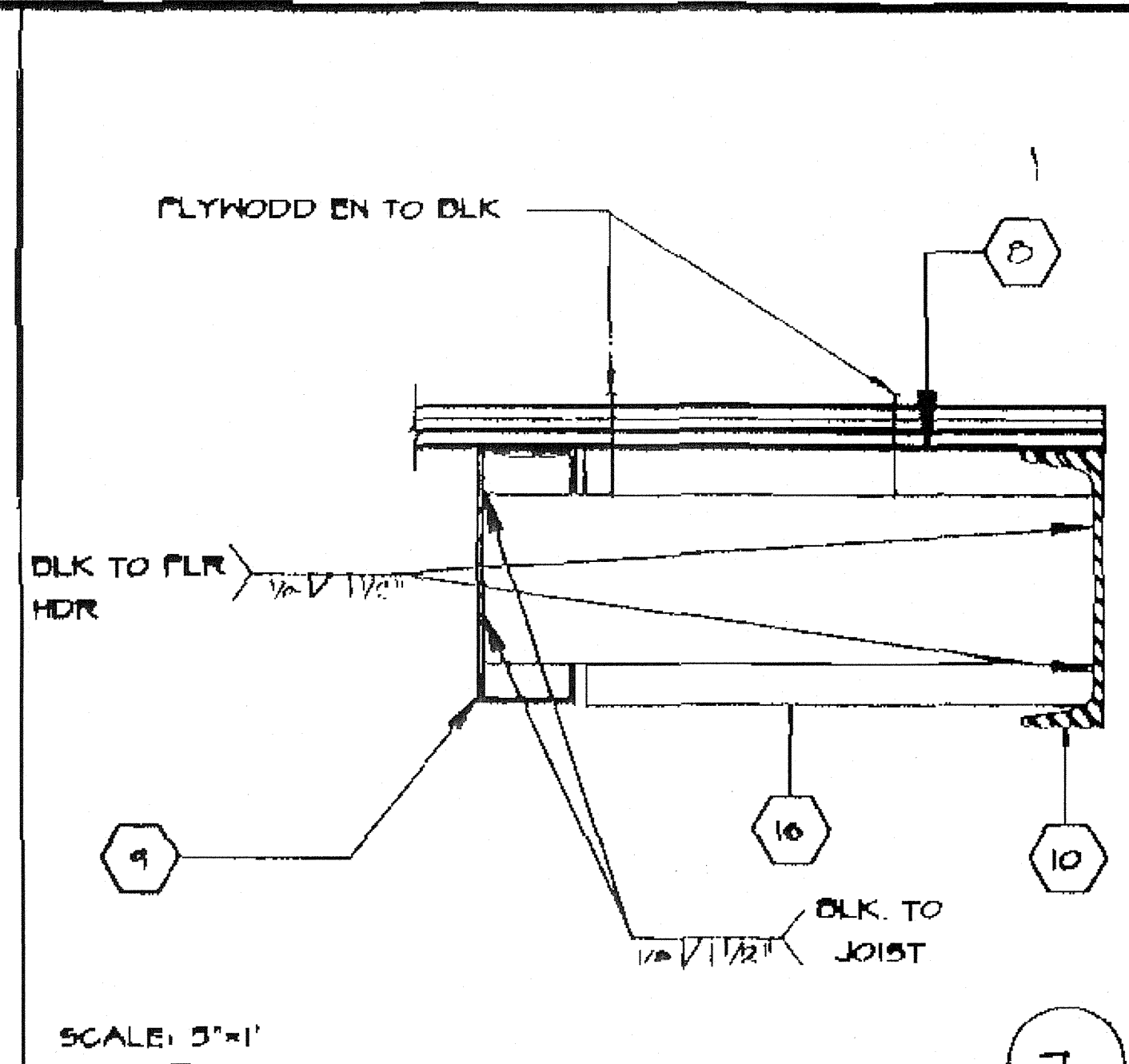

BLOCK @ MIDSPAN

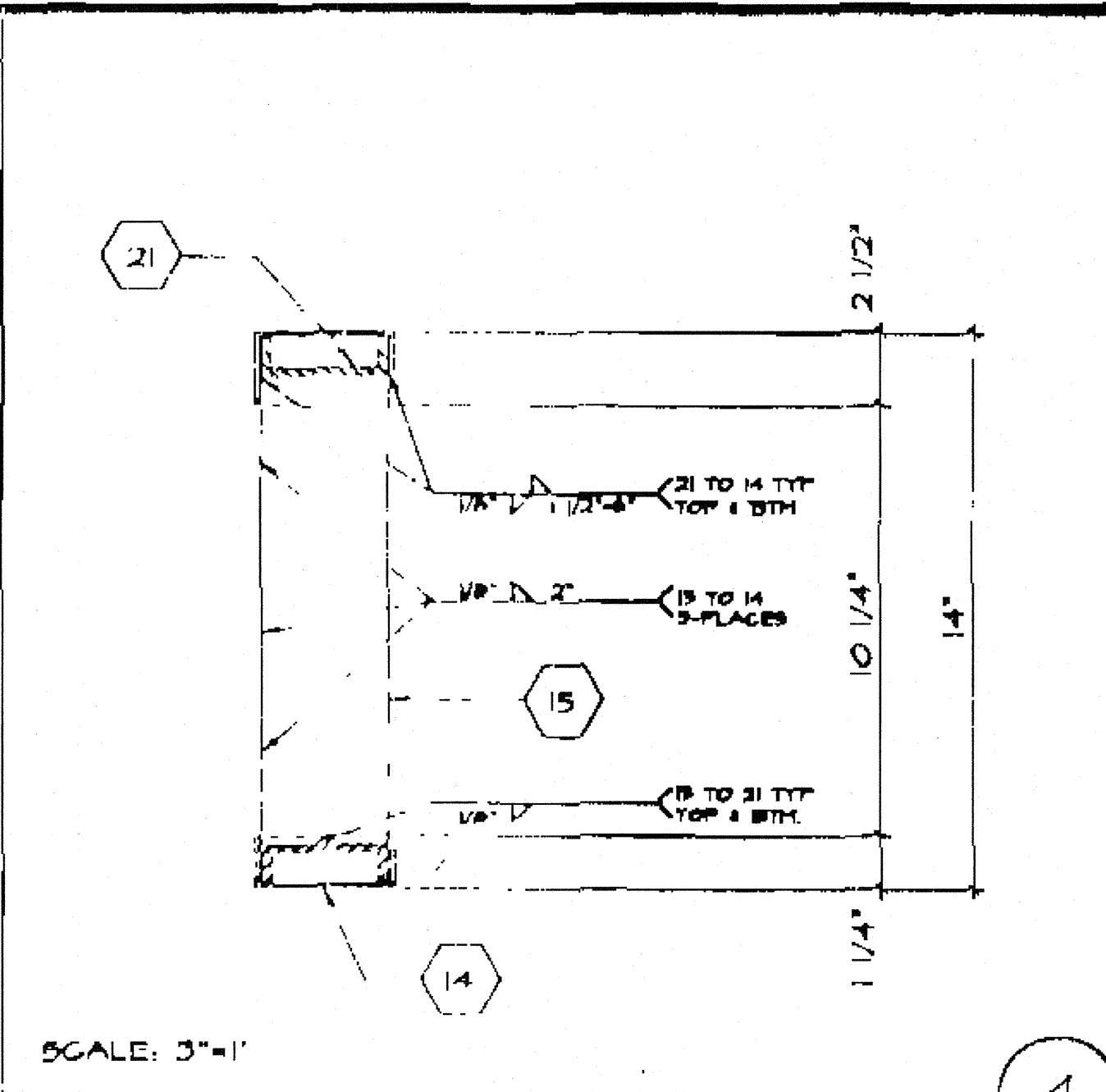

MECH. DUCT OPENING IN HEADER

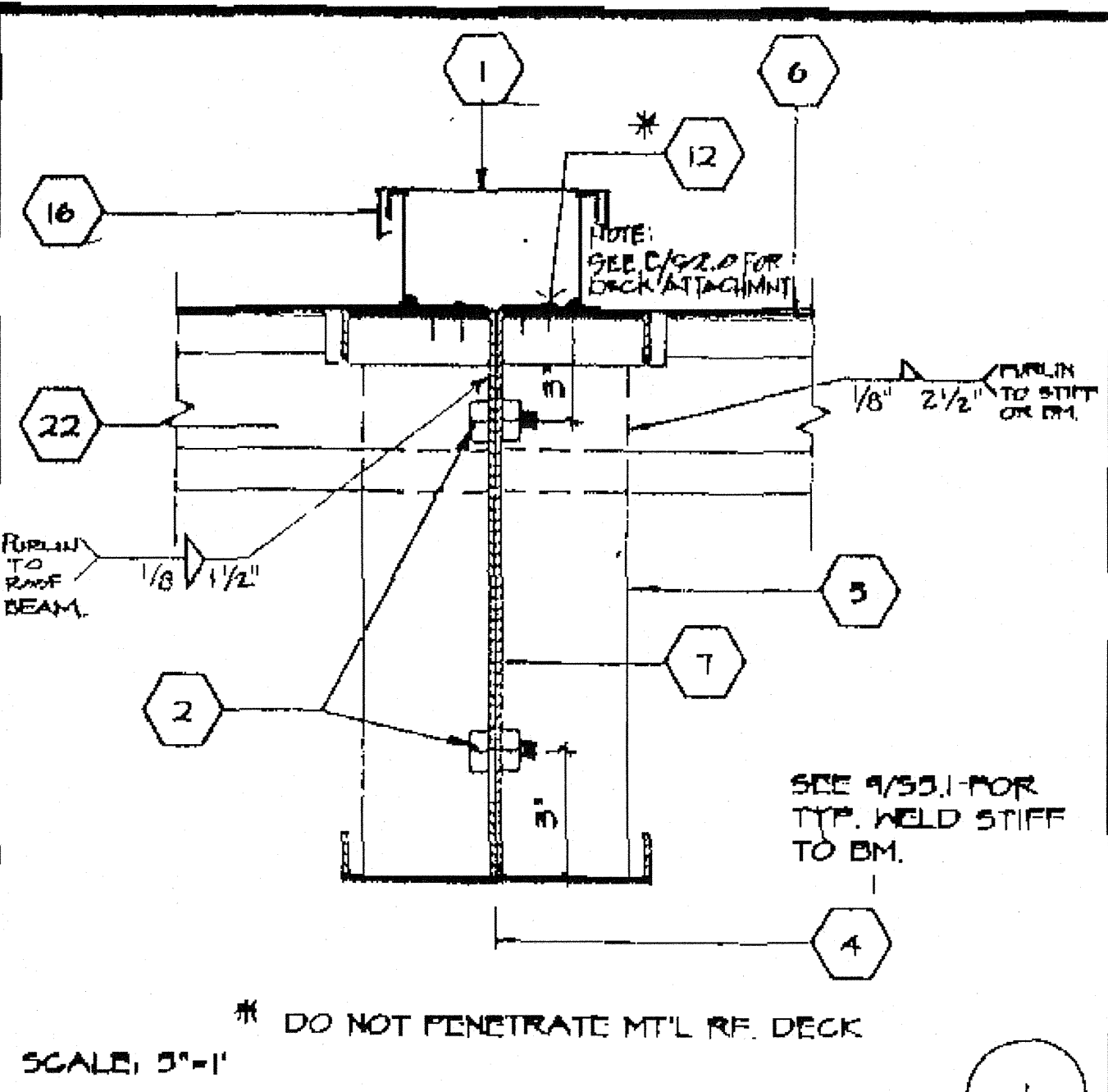

ROOFING @ MODLINE

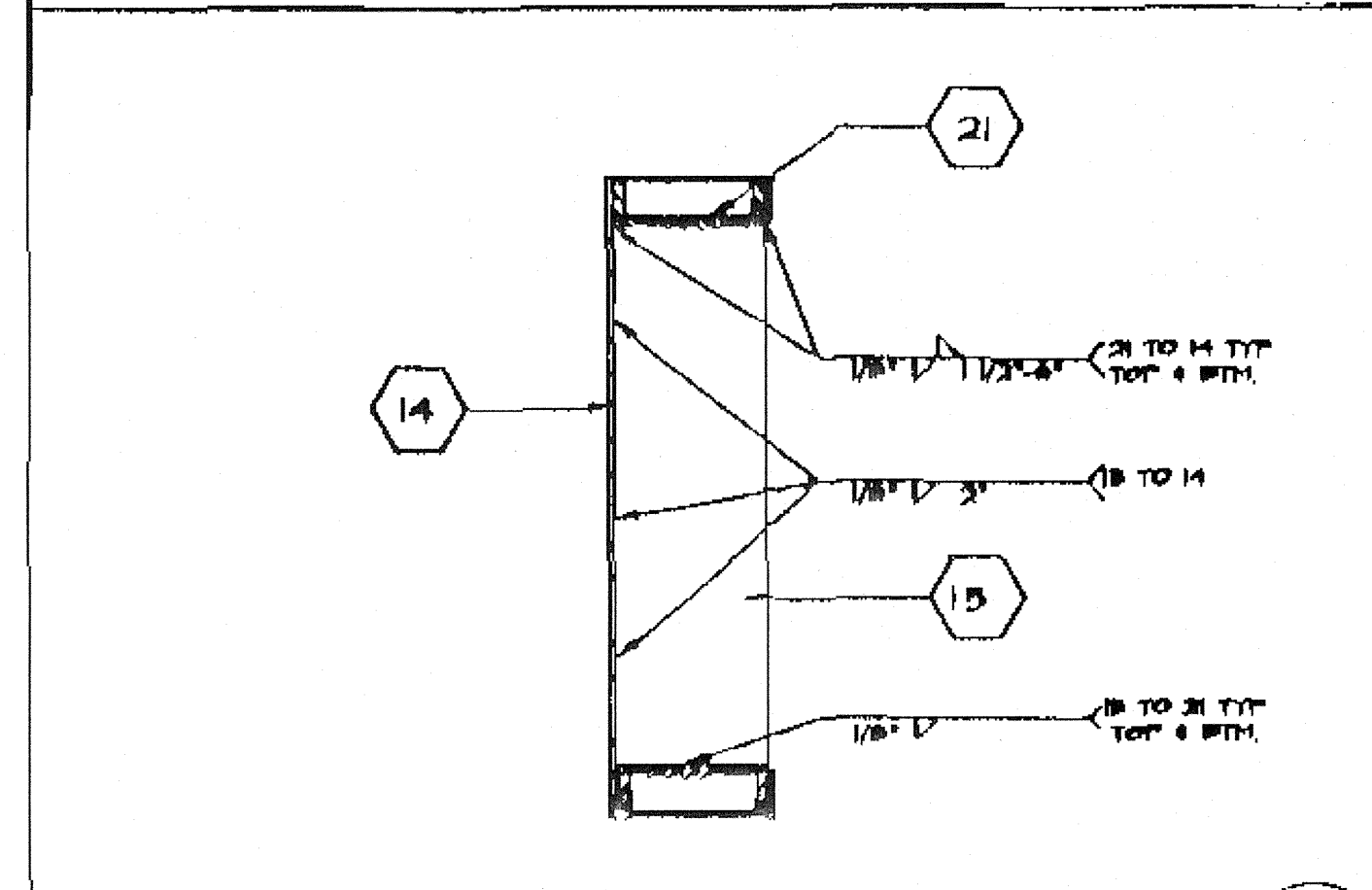

HEADER REINF. @ A.C. OPENING

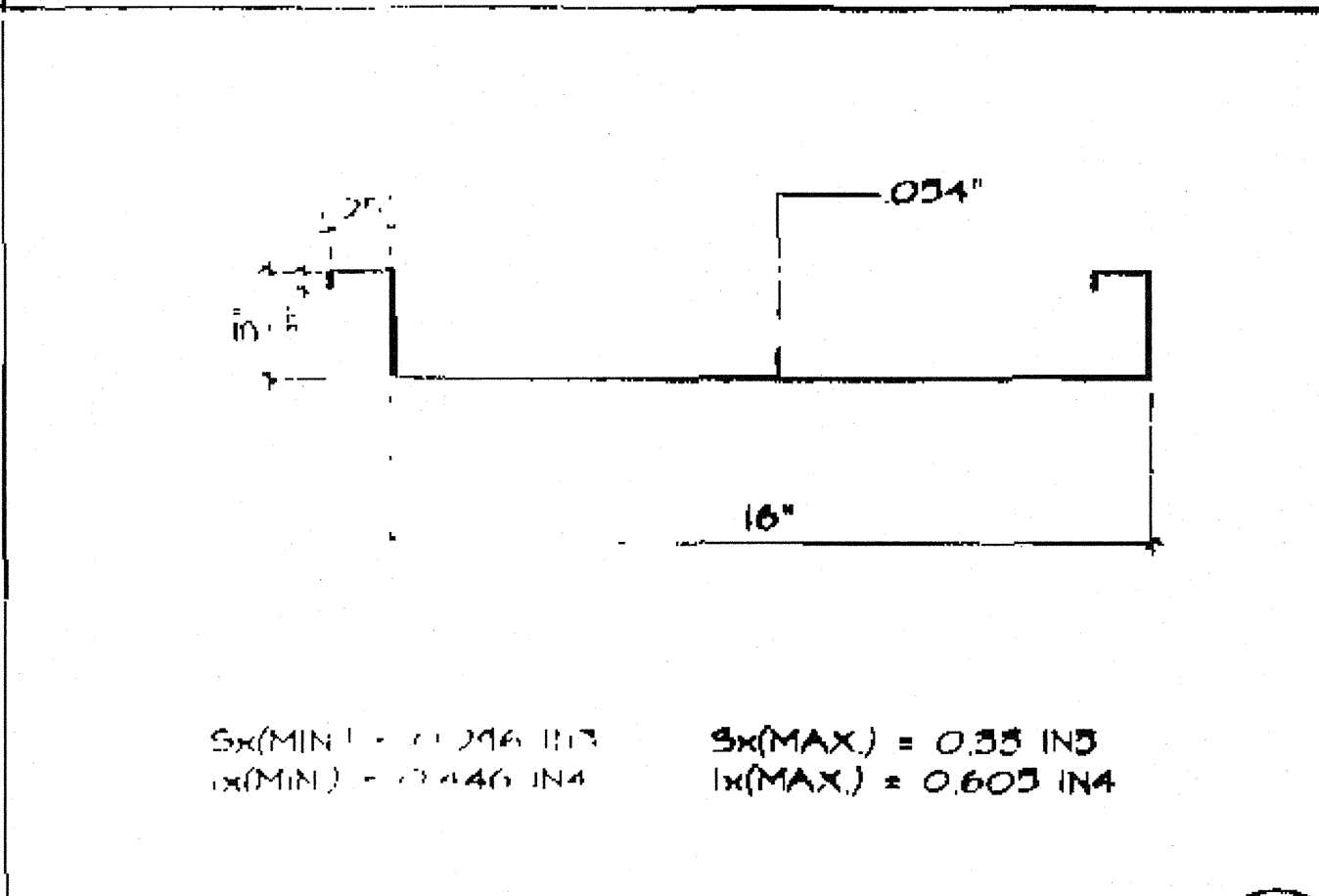

ROOF PAN (22GA)

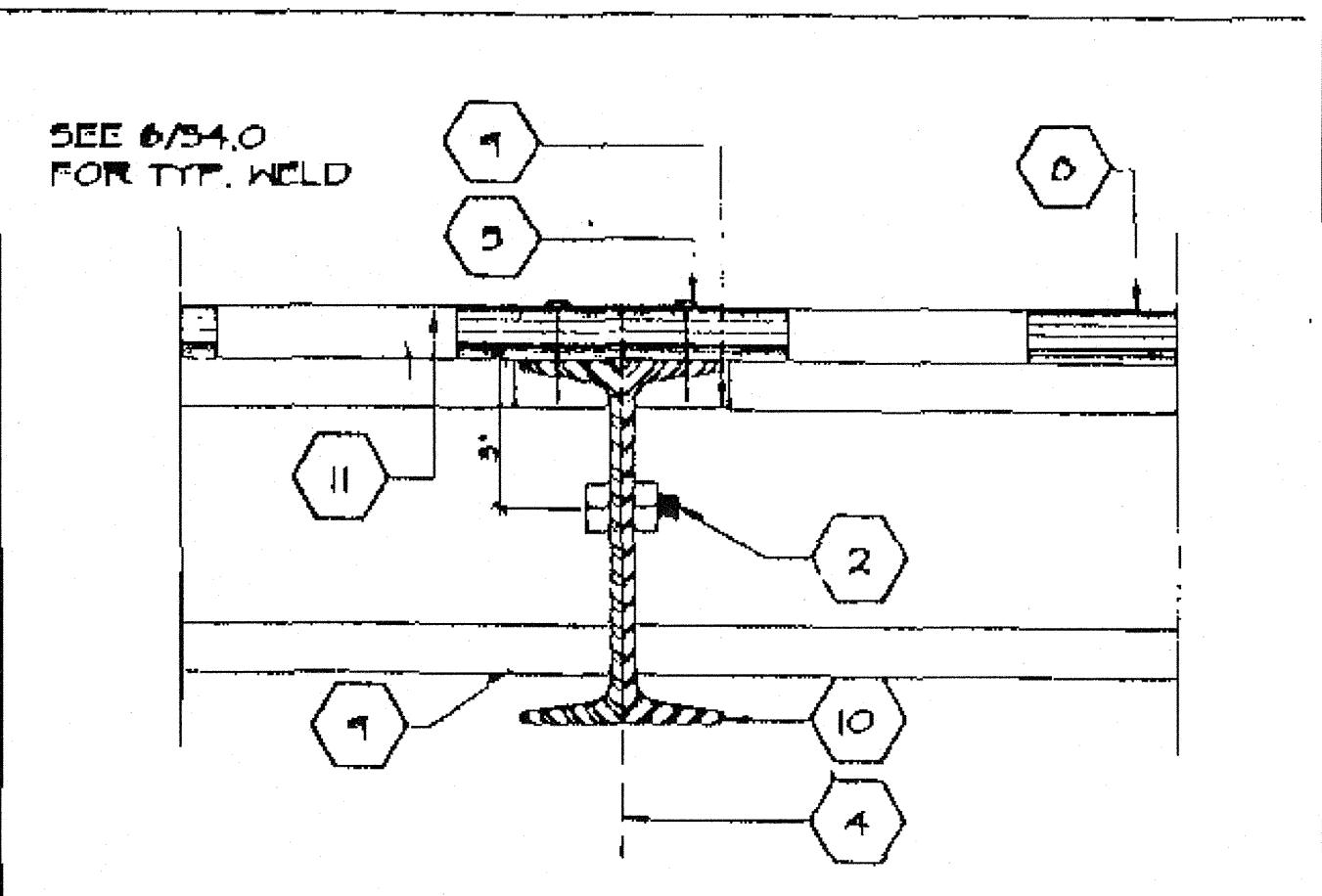

MODULE JOINT @ FLR. 12'-0"

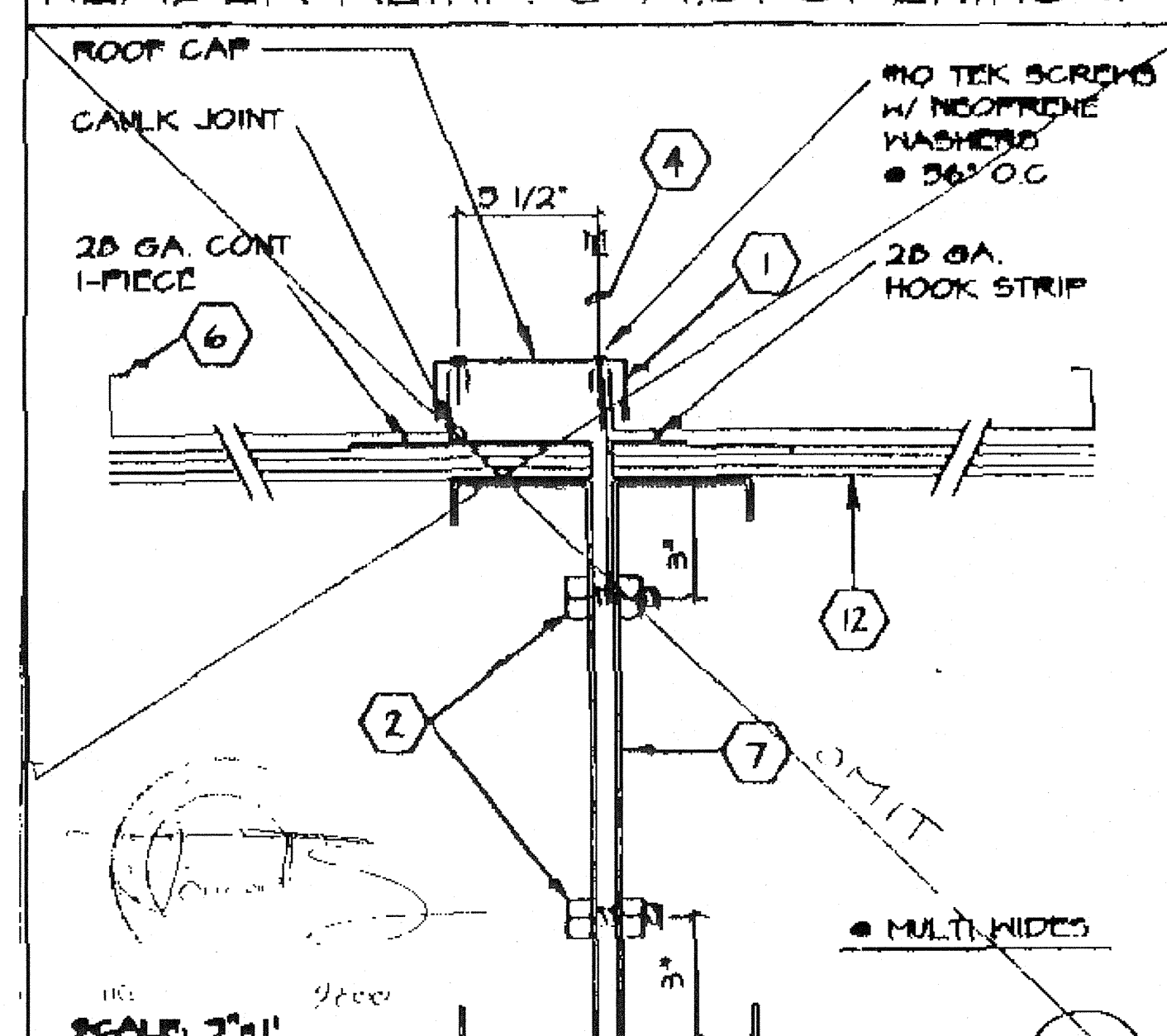

ALT. ROOFING @ MODLINE

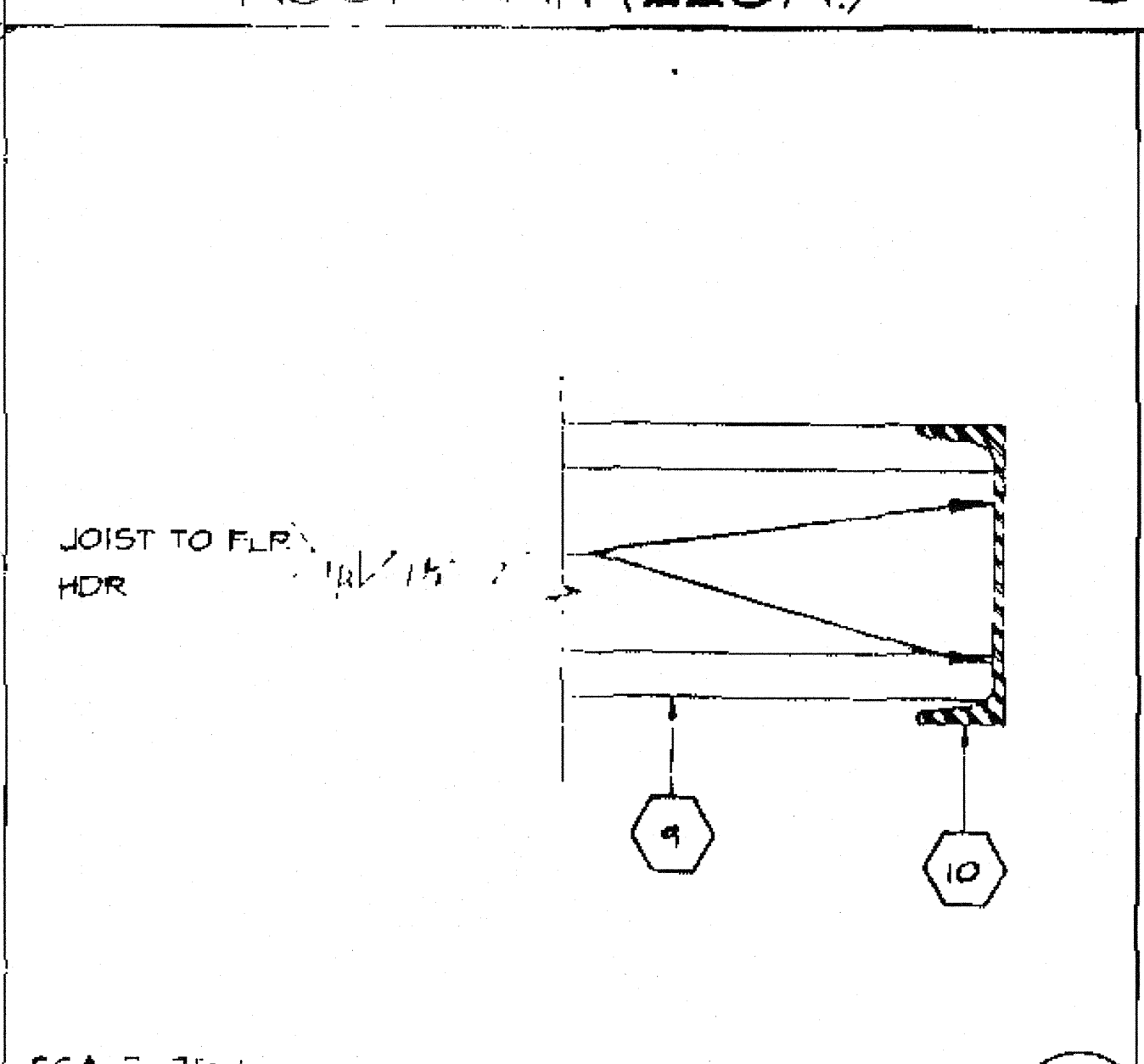

FLOOR JOIST TO BEAM

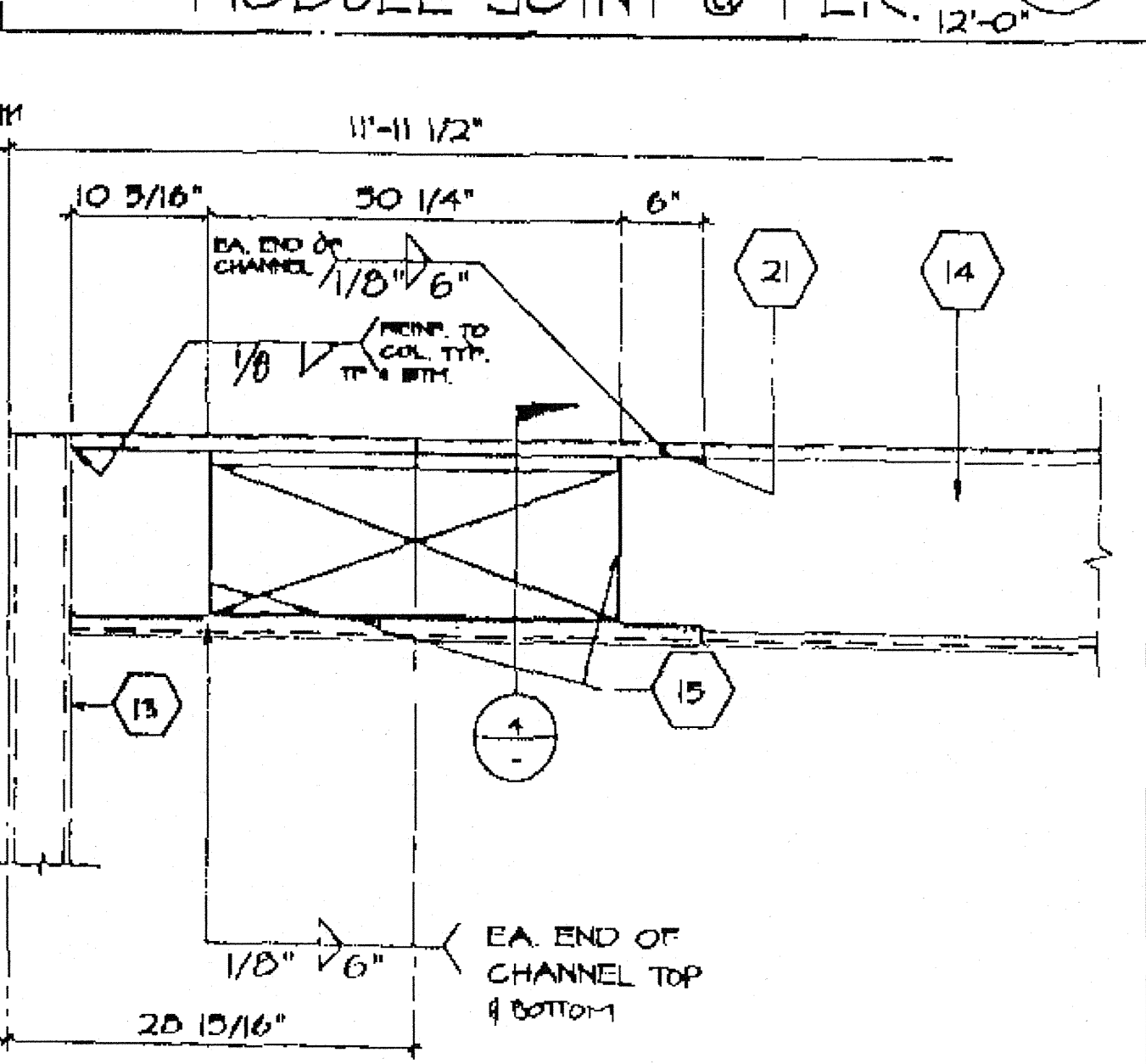

ELEVATION-OPENING

KEY NOTES

- 1 CAP CLOSURE @ MODLINE 26GA. GALV. W/10 TYPE FASTENERS W/NEOPRENE WASHERS TO RID BOTH SIDES OF MODLINE SET CAP IN SEALANT
- 2 5/8" M.B. A307 MODULE JOINT (SEE STRUCTURAL PLAN FOR LOCATION) @ 0" O.C.
- 3 EN
- 4 MODULE JOINT
- 5 1/4" @ 0" O.C. FULL DEPTH STIFFENER PLATE (SEE 4/52.1)
- 6 STANDING SEAM ROOF (SEE A2.0)
- 7 ROOF BEAM (SEE STRUCTURAL) SEE 3/52.1 & 12/52.1
- 8 PLYWOOD FLOOR SHEATHING
- 9 FLOOR JOIST 6/52.1
- 10 FLOOR BEAM (SEE STRUCTURAL 3/52.1)
- 11 HAND-HOLE @ BOLT LOCATION
- 12 #14 STGMS
- 13 3 1/2"x3 1/2"x1/4" STEEL TUBE COLUMN
- 14 ROOF HEADER (SEE STRUCTURAL 1/52.1)
- 15 1/4" STIFFENER PLATE SEE 4/52.1 FOR TYP. HELL
- 16 CAP CLOSURE AT RIDGE 26GA. GALV. W/10 STGMS AT 48" O.C. W/NEOPRENE WASHER TO RID SET BOTH SIDES OF CAP IN SEALANT
- 17 NOT USED
- 18 NOT USED
- 19 NOT USED
- 20 2"x2"x3/16" L
- 21 3 1/4"x1"x45 11/16" LX10GA CHANNEL TOP & BOTTOM CENTER OF OPENING
- 22 ROOF FURLIN SEE 2/52.1
- 23 TUBE STEEL (SEE NOTE #13)

IDENTIFICATION STAMP  
 DIV. OF THE STATE ARCHITECT  
 APPROX 115000  
 AC / PLS / SS / TB  
 DATE DEC 11 1998

ARCHITECT	ELECTRICAL	STRUCTURAL	MECHANICAL	FIRE MARSHAL	ACCESS COMPLIANCE	STRUCTURAL SAFETY
-----------	------------	------------	------------	--------------	-------------------	-------------------

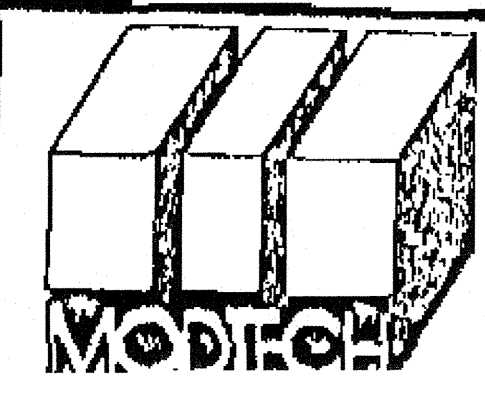

© MODTECH INC. 1994

DRAWN BY  
 DATE  
 CHECKED BY  
 DATE

S1.0

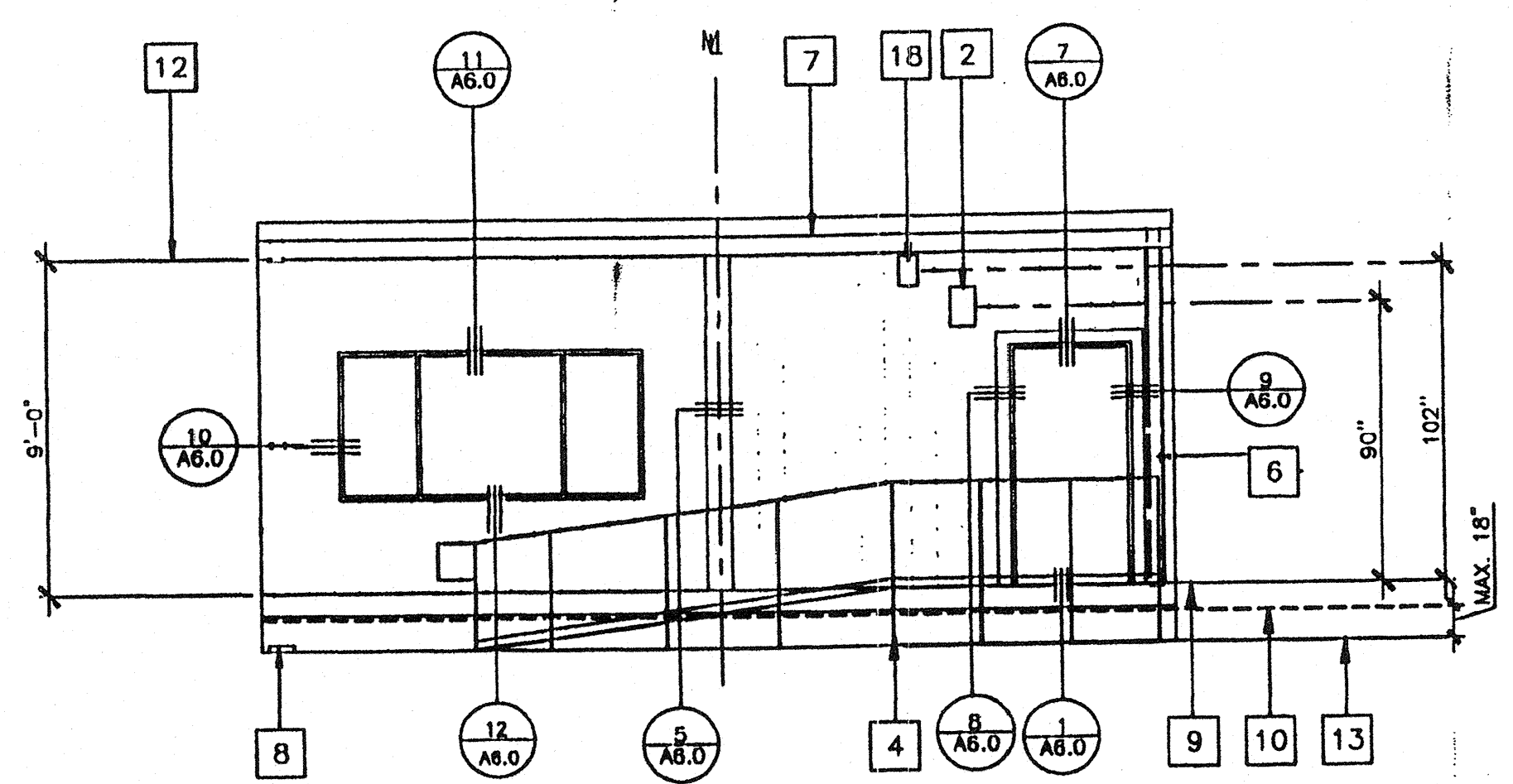

1 FRONT ELEVATION  
1/4" = 1'-0"

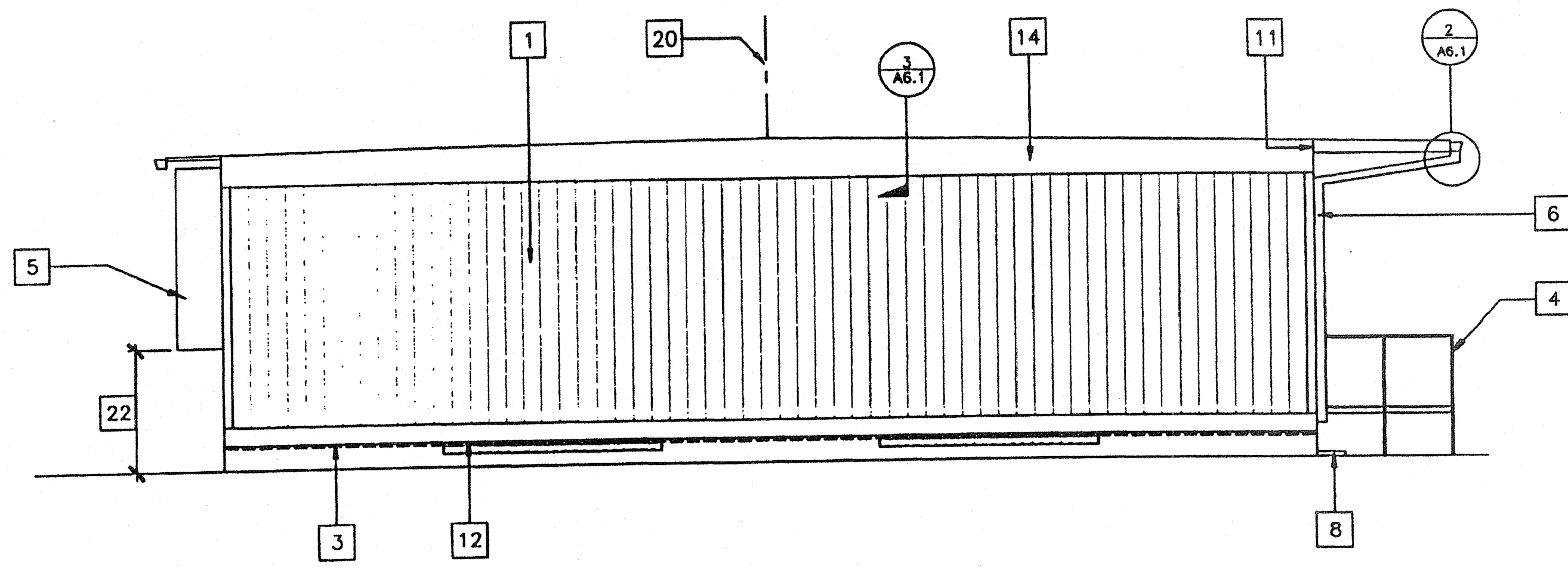

2 LEFT ELEVATION  
1/4" = 1'-0"

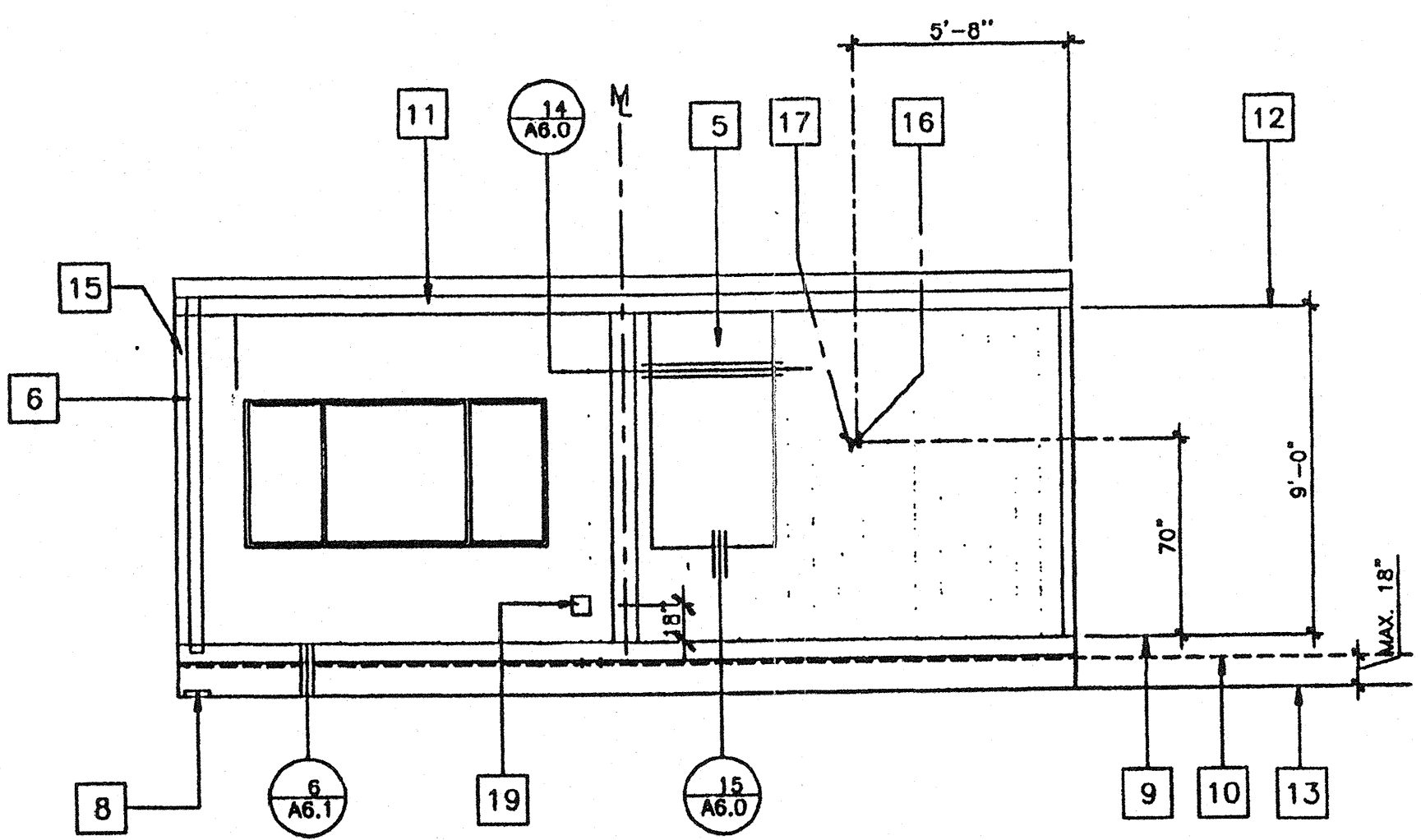

3 REAR ELEVATION  
1/4" = 1'-0"

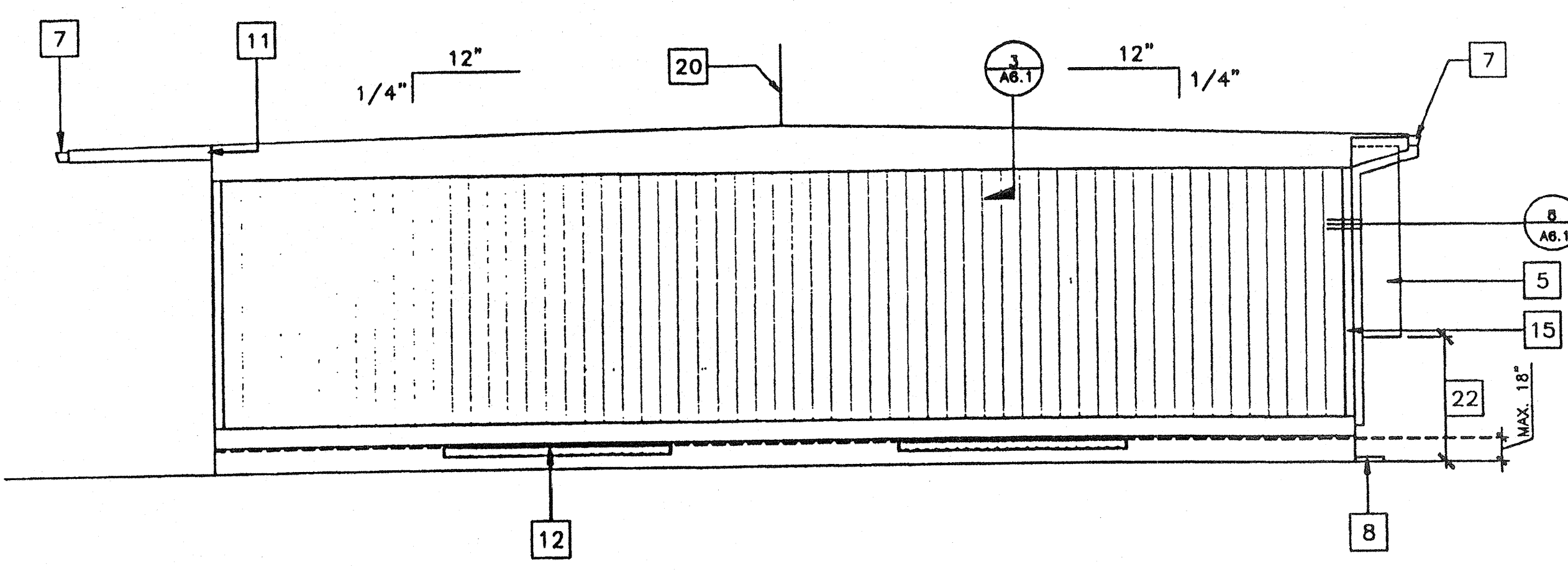

4 RIGHT ELEVATION  
1/4" = 1'-0"

"A" = SHOWN  
"B" = OPPOSITE

KEY NOTES

- 1 TYPICAL EXTERIOR SIDING (SEE A5.0)
- 2 EXTERIOR LIGHT FIXTURE (SEE SPEC'S)
- 3 TOP OF SKIRTING
- 4 RAMP AND LANDING SEE SHT. R-1
- 5 HVAC UNIT. SEE (HW)
- 6 DOWNSPOUT (TYP.) FOR (2). FASTEN TO BLD'G. TYP 3 PLACES (SEE 8/A6.1)
- 7 CONTINUOUS GUTTER WITH DOWNSPOUT (LOCATION OF DOWNSPOUT SHOWN ON ROOF PLAN) SEE A2.0
- 8 SPLASH BLOCK (BY OTHERS)
- 9 FINISH FLOOR LINE
- 10 BOTTOM FLANGE OF FLOOR BEAM
- 11 ROOF HEADER
- 12 VENT. SEE FOUNDATION PLAN
- 13 FINISH GRADE
- 14 ROOF BEAM SEE (STR)
- 15 COLUMN SEE (STR)
- 16 ELECTRICAL STUB-OUT SEE (EL)
- 17 GROUND STUB-OUT SEE (EL)
- 18 J BOX FOR EXT. FA HORN SEE (EL)
- 19 NEMA 6" X 6" GUTTER BOX SEE (EL)
- 20 RIDGE
- 21 NOT USED
- 22 IF HVAC UNIT IS LOCATED IN ANY PATH OF TRAVEL OR CIRCULATION AREA AND HEIGHT FROM GRADE TO BOTTOM OF UNIT EXCEEDS 27" THEN PROTECTION MUST BE PROVIDED.

NOTES

- 1. SEE FOUNDATION PLAN FOR SIZE AND LOCATION OF UNDER FLOOR VENTS.

IDENTIFICATION STAMP  
DIV. OF THE STATE ARCHITECT  
OFFICE OF REGULATION SERVICES  
04 01984  
AC 6 FLS SS  
DATE MAR 09 2009

IDENTIFICATION STAMP  
DIV. OF THE STATE ARCHITECT  
APPROX 115800  
AC 11 FLS SS  
DATE 7/24/14

CBC 1998 PC

REVISIONS	Electrical Engineer's Seal	Mechanical Engineer's Seal	Architect's Seal

Electrical Engineer's Seal

Mechanical Engineer's Seal

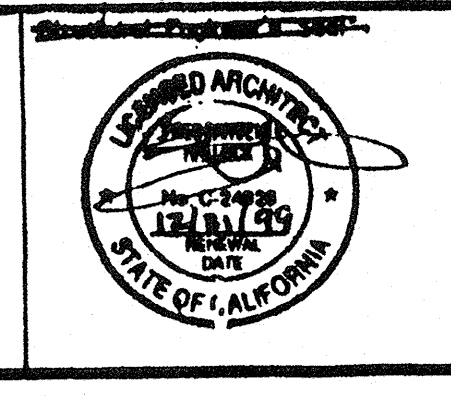

Architect's Seal

IDENTIFICATION STAMP  
DIV. OF THE STATE ARCHITECT  
OFFICE OF REGULATION SERVICES  
PC-04  
101419  
AC 11 FLS SS  
DATE OCT 23 1995

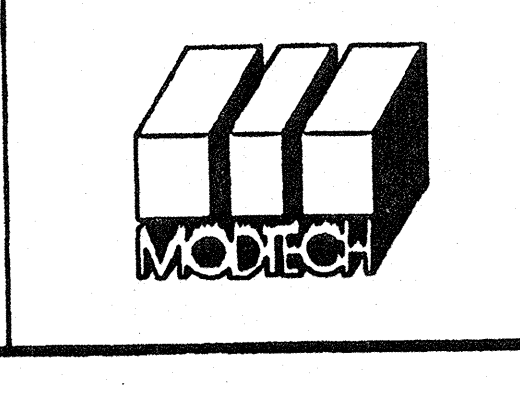

**MODTECH INC.**  
2830 BARRETT AVENUE  
PERRIS, CALIF. 92572  
PH (909) 943-4014  
FAX (909) 940-0427

PROJECT NUMBER:

© MODTECH, INC. 1999

DRAWN BY:  
DATE:  
CHECKED BY: SS  
DATE: 10/22/99  
MODTECH Index No.  
**A3.0**

EXTERIOR ELEVATIONS

PROJECT NO. PC-04-101419

JOB # 3405

MODTECH DESIGN MT-2440

PC 04-101419

RELOCATABLE CLASSROOM BUILDINGS  
BUILDING SIZE: 24'x40'

FOR

WILLIAMS SCOTSMAN

(56) BUILDINGS

STOCKPILE

BUILDING DATA

STRUCTURAL DESIGN: RIGID FRAME  
TYPE OF CONSTRUCTION: V-N  
WIND LOAD (EXP C): 80 MPH  
FLOOR LIVE LOAD: 50 PSF  
ROOF LIVE LOAD: 20 PSF  
OCCUPANCY: 24'x40' CLASSROOM: E-2

BUILDING AREA:  
24'x40' BUILDING - 960 SF

APPLICABLE CODES

- TITLE 24, CCR, PART 2, 1998 CBC (97 UBC W/98 CA AMENDMENTS)
- 1997 UBC & 1998 CA AMENDMENTS (98 CBC - PART 2, TITLE 24, CCR)
- 1998 NEC & 1998 CA AMENDMENTS (98 CEC - PART 3, TITLE 24, CCR)
- 1997 UMC & 1998 CA AMENDMENTS (98 CMC - PART 4, TITLE 24, CCR)
- 1997 UPC & 1998 CA AMENDMENTS (98 CPC - PART 5 TITLE 24, CCR)
- 1997 UFC & 1998 CA AMENDMENTS (98 CFC - PART 9, TITLE 24, CCR)
- 1998 CA BUILDING STANDARDS CODE
- TITLE 19, CCR, PUBLIC SAFETY, STATE FIRE MARSHAL REGULATIONS.

LEGEND

SYMBOL	DESCRIPTION
	DETAIL (1) ON SAME SHEET AS SYMBOL
	DETAIL (1) ON SHEET (2)
	KEY NOTE (1) ON SAME SHEET AS SYMBOL
	SECTION "A" ON SHEET (2)
	REVISION/CHANGE IN DRAWING. (1) IS FIRST REVISION
	HIGHLIGHTS CHANGED AREA
	DOOR REFERENCE
	WINDOW REFERENCE
	ELECTRICAL ITEM(S) SEE ELECTRICAL DRAWINGS
	HEATING/VENTILATING & AIR CONDITIONING ITEM(S) SEE MECHANICAL DRAWINGS
	PLUMBING ITEM(S) SEE MECHANICAL DRAWINGS
	STRUCTURAL ITEM(S) SEE STRUCTURAL DRAWINGS
	FINISH ITEM(S) SEE FINISH SCHEDULE
	RAMP - SEE RAMP DRAWINGS

ABBREVIATIONS

- AGC = ABOVE GRADE CONCRETE
- BGC = BELOW GRADE CONCRETE
- DIA = DIAMETER
- CLR = CLEAR
- GA = GAUGE
- SIM = SIMILAR
- MAX = MAXIMUM
- MIN = MINIMUM
- NIC = NOT IN CONTRACT
- NTS = NOT TO SCALE
- OC = ON CENTER
- OD = OUTSIDE DIAMETER
- OSB = ORIENTED STRAND BOARD
- ROH = ROOF OVERHANG
- SIM = SIMILAR
- STS = SELF TAPPING SCREW
- STSMS = SELF TAPPING SHEET METAL SCREW
- TYP = TYPICAL
- UON = UNLESS OTHERWISE NOTED

WITH THE SIGNING OF THESE DRAWINGS, WE ACKNOWLEDGE THAT WE HAVE REVIEWED THESE PLANS AND SPECIFICATIONS AND HAVE FOUND THEM TO BE IN GENERAL COMPLIANCE WITH THE BID DRAWINGS, SPECIFICATIONS AND ASSOCIATED ADDENDA. WHEN THESE PLANS AND SPECIFICATIONS HAVE BEEN APPROVED BY THE DIVISION OF THE STATE ARCHITECT, THEY SHALL PRESIDE OVER CONFLICTING AREAS IN THE BID DRAWINGS AND SPECIFICATIONS, AND ANY ADDENDA THERETO.

CONFIDENTIAL - THIS DOCUMENT AND THE INFORMATION CONTAINED HEREIN ARE THE PROPERTY OF MODTECH, INC. UNAUTHORIZED COPYING, DISCLOSURE OR OTHER UNAUTHORIZED USES ARE PROHIBITED.

SHEET INDEX

ARCHITECTURAL	
A.0	TITLE SHEET
A1.0	FLOOR PLAN 24'x40'
A2.0	ROOF PLAN (DUAL PITCH) 24'x40'
A3.0	EXTERIOR ELEVATIONS (DUAL PITCH) 24'x40' W/ FASCIA
A4.0	INTERIOR ELEVATIONS 24'x40'
A5.0	WALL, WINDOW, DOOR, PARTITION FINISHES
A6.0	WINDOW DETAIL (TYPICAL)
A7.0	DOOR DETAIL (TYPICAL)

A8.0	REFLECTED CEILING PLAN (24'x40') (13 LIGHTS)
A9.0	REFLECTED CEILING OF DETAIL

STRUCTURAL	
F1.0	FOUNDATION PLAN (24 x 40) :40 PSI LL (WOOD)
F2.0	FOUNDATION DETAILS (WOOD)
S1.0	FLOOR FRAMING PLAN (98 CBC)
S1.2	FLOOR FRAMING DETAILS (TYPICAL)
S2.0	ROOF FRAMING PLAN (DUAL PITCH) W/ FASCIA
S2.1	ROOF FRAMING DETAILS (TYPICAL)
S3.0	STRUCTURAL ELEVATIONS & DETAILS (DUAL PITCH)
S4.0	WALL FRAMING (WOOD)
S5.0	WALL FRAMING DETAILS (WOOD)
S6.0	WALL FRAMING DETAILS (WOOD)

MECHANICAL	
M1.0	MECHANICAL (HVAC) PLAN 24'x40' 3 1/2 TONS

ELECTRICAL	
E1.0	ELECTRICAL PLAN 24'x40'

RAMP	
R1.00	RAMP/LANDING PLAN W/ 11' RAMP
R1.02	RAMP/STAIRS DETAILS

IDENTIFICATION STAMP  
DIV. OF THE STATE ARCHITECT  
OFFICE OF REGULATION SERVICES

04 10 1998  
AC: C.E.S. / S.S.G.  
DATE: MAR 9 2007

PLS: E.P. / J.  
RCP: C. / J.  
SS: C.P. / W.A.

IDENTIFICATION STAMP  
DIV. OF THE STATE ARCHITECT

APPROX 115000  
AC: J.W. / S.S.B.  
DATE: 7/24/14

JBB#3405

CBC 1997 PC

REVISIONS	Electrical Engineer's Seal	Mechanical Engineer's Seal	Architect's Seal

Architect's Seal

Architect's Seal

IDENTIFICATION STAMP  
DIV. OF THE STATE ARCHITECT  
OFFICE OF REGULATION SERVICES

PC-04  
101419

DATE: JAN 12 2006  
AC: D.P. / S.S.  
RCP: D.P. / W.A.  
PRO: E.P. / J.

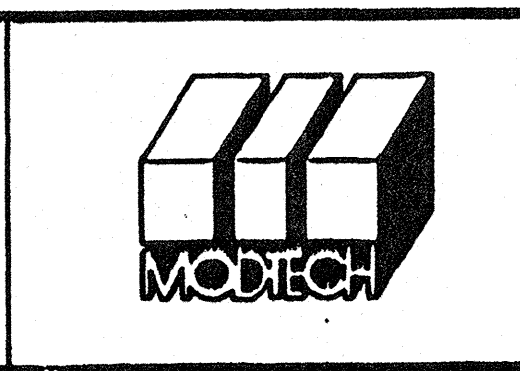

**MODTECH INC.**  
2830 BARRETT AVENUE  
PERRIS, CALIF. 92572  
PH (909) 943-4014  
FAX (909) 940-0427

PROJECT NUMBER: 3405  
© MODTECH, INC. 1999

DRAWN BY: [Signature]  
DATE: 10/22/99  
CHECKED BY: [Signature]  
DATE: 10/22/99  
MODTECH Index No. [Signature]  
**A.0**

COVER SHEET

3405



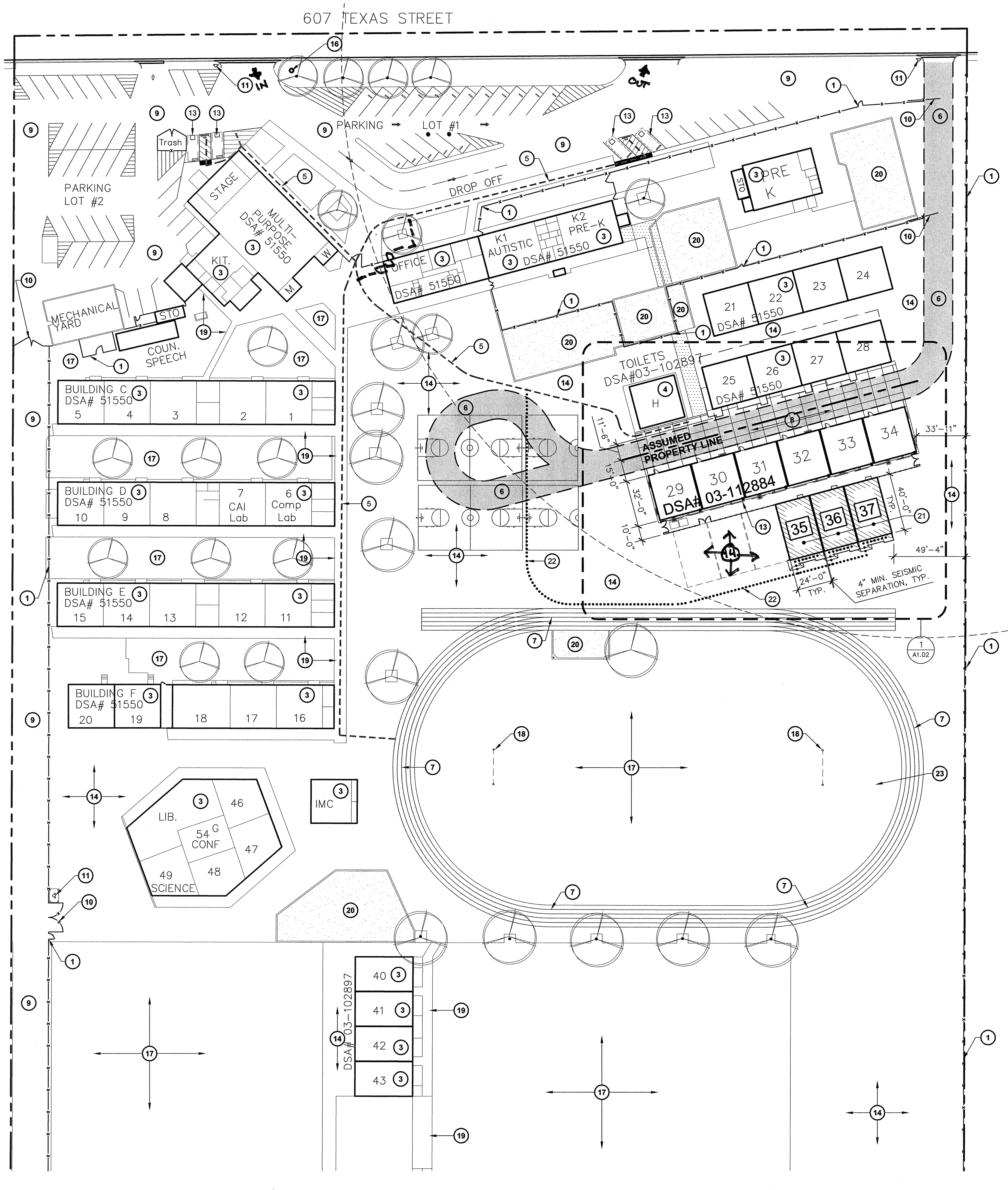
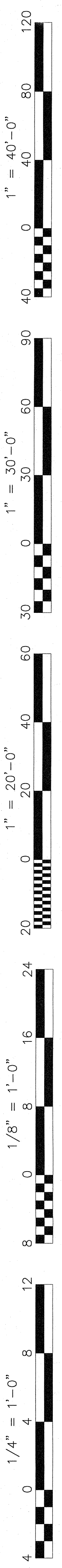

**SITE PLAN**  
**FREMONT ELEMENTARY SCHOOL**

SCALE: 1" = 40'

**GENERAL NOTES**

- A. GENERAL CONTRACTOR SHALL FIELD VERIFY ALL SITE CONDITIONS PRIOR TO BID. IF ANY DISCREPANCIES ARE FOUND, THE ARCHITECT SHALL BE NOTIFIED IN WRITING.
- B. CONTRACTOR SHALL BE RESPONSIBLE FOR THE CORRECTNESS OF LAYOUTS AND ESTABLISHED LOCATIONS OF BURIED UTILITY LINES. ANY UTILITIES REQUIRING RELOCATION SHALL BE THE RESPONSIBILITY OF THE GENERAL CONTRACTOR CONTACT APPLICABLE GOVERNING AGENCIES REGARDING ARRANGEMENT AND COORDINATION OF WORK.
- C. GENERAL CONTRACTOR WILL BE RESPONSIBLE FOR ANY COMPACTION RETEST DUE TO INITIAL FAILURE.
- D. PROJECT INSPECTOR SHALL BE EMPLOYED BY THE OWNER, APPROVED BY THE RESPONSIBLE ARCHITECT AND DSA.
- E. A COPY OF TITLE-24, ALL PARTS APPLICABLE, TO BE KEPT AT THE JOB SITE AT ALL TIMES.
- F. ADDENDA SHALL BE SIGNED BY THE ARCHITECT (RESPONSIBLE IN CHARGE) AND APPROVED BY DSA.
- G. C.C.D.s SHALL BE SIGNED BY THE ARCHITECT (RESPONSIBLE IN CHARGE), OWNER AND APPROVED BY DSA.
- H. TESTING LAB SHALL BE EMPLOYED BY THE OWNER, APPROVED BY THE RESPONSIBLE ARCHITECT AND DSA.
- I. ALL WORK SURFACES DISTURBED OR DAMAGED BY THE CONSTRUCTION ACTIVITIES SHALL BE REPAIRED IN KIND, TEXTURED AND FINISHED TO MATCH ADJACENT SURFACES.
- J. NEW CONCRETE WALKS SHALL HAVE SLOPES NOT TO EXCEED 1 IN 20 IN THE DIRECTION OF PATH OF TRAVEL. PROVIDE CONTROL JOINTS ("C.J.") AT 5'-0" o.c. MAX. AND EXPANSION JOINTS NOT TO EXCEED 30'-0" MAX. PROVIDE MEDIUM BROOM FINISH ON ALL WALKS.
- K. ALL BUILDING AND ROOM NAMES INDICATED ON THESE CONSTRUCTION DOCUMENTS ARE "NOT" THE ACTUAL BUILDING/ ROOM SIGNAGE DESIGNATION. THE GENERAL CONTRACTOR SHALL FURNISH, INSTALL AND COORDINATE ALL REQUIRED SIGNAGE WITH THE OWNER/ARCHITECT PRIOR TO STARTING CONSTRUCTION.
- L. GENERAL CONTRACTOR WILL BE RESPONSIBLE TO COORDINATE RELOCATABLE BUILDING DELIVERY DATES TO THE SCHOOL SITE WITH THE MFG.
- M. THE GENERAL CONTRACTOR SHALL CONSTRUCT ALL NEW RELOCATABLE BUILDING FOUNDATIONS AS PER THE RELOCATABLE BUILDING MANUFACTURER'S DRAWINGS AND SPECIFICATIONS.
- N. THE GENERAL CONTRACTOR SHALL BE RESPONSIBLE TO PROVIDE ALL HOOK-UPS TO THE RELOCATABLE BUILDINGS AFTER INSTALLATION HAS BEEN COMPLETED BY THE MANUFACTURER.
- O. 5'-0" DEEP x 5'-0" WIDE MINIMUM LANDINGS AT DOORWAYS SHALL BE AS DETAILED AND SHALL HAVE SLOPES (IN ANY DIRECTION) OF NOT GREATER THAN 1/4 IN 12 SLOPE. SLOPES SHALL BE AWAY FROM DOORWAYS.
- P. GENERAL/SITE CONTRACTOR SHALL FIELD VERIFY THAT EXISTING PATH OF TRAVEL (P.O.T.) IS A MINIMUM OF 4'-0" WIDE AND IS SLIP RESISTANT. IF IT IS NOT, THEN THE CONTRACTOR SHALL NOTIFY THE ARCHITECT OF RECORD AND A REMEDY OR ALTERNATE P.O.T. WILL BE PROVIDED.
- Q. THE MAXIMUM DROP BETWEEN EXISTING FINISHED GRADES AND THE TOP OF THE P.O.T. SHOULD NOT EXCEED 4". IF IT DOES, PROVIDE THE NECESSARY WARNING CURB PER CBC SEC. 11B-303.5.

**KEYNOTES**

1. EXISTING CHAIN LINK FENCE AND GATE TO REMAIN
2. EXISTING ACCESSIBLE PARKING SIGNAGE, DSA# 03-102897, MOUNTED TO EXISTING C.L. FENCE
3. EXISTING BUILDING TO REMAIN, NO WORK
4. EXISTING ACCESSIBLE RESTROOM BUILDING PER DSA# 03-102897, NO WORK
5. EXISTING ACCESSIBLE PATH OF TRAVEL TO REMAIN, VERIFY IN FIELD
6. EXISTING 20' WIDE FIRE TRUCK ACCESS LANE OVER EXISTING PAVING, APPROVED BY THE LOCAL JURISDICTION.
7. EXISTING TRACK STRIPING TO REMAIN
8. EXISTING CONCRETE WALK WITH MEDIUM BROOM FINISH
9. EXISTING A.C. PAVED PARKING LOT TO REMAIN
10. EXISTING 20' WIDE CHAIN LINK FIRE TRUCK ACCESS GATE. PROVIDE NEW KNOX PAD LOCK PER KERN COUNTY STANDARDS
11. EXISTING FIRE HYDRANT TO REMAIN
12. EXISTING PAIR OF 48" ACCESSIBLE GATES TO REMAIN LOCKED IN THE OPEN POSITION DURING SCHOOL HOURS
13. EXISTING ACCESSIBLE PARKING STALL PER DSA APPL. #03-112884
14. EXISTING A.C. PAVING TO REMAIN
15. PROVIDE 2" WIDE WHITE STRIPING WHERE REQUIRED TO MATCH WITH EXISTING TRACK CONFIGURATION WITHIN THE AREA OF THE NEW AC-PAVING
16. EXISTING TOW-AWAY SIGN MOUNTED TO EXISTING POLE PER DSA APPL. #03-112884
17. EXISTING TURF TO REMAIN, NO WORK
18. EXISTING GOAL POST TO REMAIN
19. EXISTING CONCRETE WALK TO REMAIN
20. EXISTING SAND BOX PLAY AREA TO REMAIN
21. NEW MODULAR CLASSROOM ON WOOD FOUNDATION w/ METAL RAMPS INSTALLED PER MANUFACTURER'S DRAWINGS
22. PROPOSED ACCESSIBLE PATH OF TRAVEL (P.O.T.) REFER TO ACCESSIBILITY NOTE, THIS SHEET

**PARKING CALCULATION**

PARKING LOT #1	
TOTAL STALLS PROVIDED:	27
ACCESSIBLE STALLS REQUIRED PER CBC TABLE 11B-208.2:	2
VAN SPACES REQUIRED (1 PER 6 ADA):	1
ACCESSIBLE STALLS PROVIDED:	1 REGULAR 1 VAN 2 TOTAL
PARKING LOT #2	
TOTAL STALLS PROVIDED:	37
ACCESSIBLE STALLS REQUIRED PER CBC TABLE 11B-208.2:	2
VAN SPACES REQUIRED (1 PER 6 ADA):	1
ACCESSIBLE STALLS PROVIDED:	1 REGULAR 1 VAN 2 TOTAL

**ACCESSIBILITY NOTES**

- ARCHITECT HAS INSPECTED THE PATH OF TRAVEL (P.O.T.) AS INDICATED ON THE PLANS AND HAS FOUND IT TO BE, OR HAS INDICATED ON THE PLANS REMEDIAL WORK WHICH WOULD CAUSE IT TO BE, A BARRIER-FREE ACCESSIBLE ROUTE:
- AT LEAST 48" IN WIDTH; OR AS APPROVED BY CODE
  - FREE OF ABRUPT LEVEL CHANGES EXCEEDING 1/4" IF BEVELED AT 1:2 MAX SLOPE, OR VERTICAL LEVEL CHANGES EXCEEDING 1/4"
  - WITH A FIRM, STABLE, AND SLIP RESISTANT WALKING SURFACE
  - WITH A RUNNING SLOPE OF 1:20 (5%) OR LESS AND WITH A CROSS SLOPE OF 1:50 (2%) OR LESS OR A RAMP WITH A RUNNING SLOPE OF 1:12 (8.33%) AND A CROSS SLOPE OF 1:50 (2%) WITH APPROPRIATE REQUIREMENTS AS DETAILED WITHIN THIS SET OF DOCUMENTS.
  - IS FREE OF OVERHEAD OBSTRUCTIONS WITHIN 80" ABOVE THE WALKING SURFACE
  - IS FREE OF OBJECTS WHICH PROTRUDE MORE THAN 4" BETWEEN THE HEIGHTS OF 27" AND 80" ABOVE THE WALKING SURFACE

**LEGEND**

- INDICATES EXISTING BUILDING TO REMAIN (NO WORK)
- INDICATES NEW PORTABLE BUILDING UNDER THIS APPLICATION
- INDICATES EXISTING FIRE TRUCK ACCESS OVER AC PAVING
- HALF-TONE DASHED LINE INDICATES EXISTING ACCESSIBLE PATH OF TRAVEL
- DOTTED LINE INDICATES PROPOSED ACCESSIBLE PATH OF TRAVEL, THIS APPLICATION

Ownership of Documents  
This document, the ideas and designs incorporated herein, as an instrument of Professional Service is the property of Integrated Designs by SOMAM Inc. and is not to be used, in whole or in part for any other project without written authorization.  
© COPYRIGHT 2014

**integrated designs** by SOMAM, Inc.  
ARCHITECTURE • INTERIOR DESIGN • CONSTRUCTION MANAGEMENT  
8011 N. Fresno, Suite 130 - Fresno, California 93710  
Phone (559) 438-0881 Fax (559) 438-0887 E-Mail: design@somam.com  
www.integrateddesigns.com

Rev.:	Date:
Rev.:	Date:
Rev.:	Date:

**SITE PLAN**

**3 RELOCATABLE CLASSROOMS**  
**FREMONT ELEMENTARY SCHOOL**  
BAKERSFIELD CITY SCHOOL DISTRICT  
607 TEXAS ST., BAKERSFIELD, CA 93307

Issue Date: 05/27/14  
Date: 06/18/14  
Designer: [Signature]  
DR: [Signature]  
PC: C-JH

Agency Approval Stamp:

IDENTIFICATION STAMP  
DIV OF THE STATE ARCHITECT  
APPROVED 715590  
AC: [Signature] FL: [Signature] SS: [Signature] TB: [Signature]  
DATE: 7/29/14

Stamp(s):

Job No.: **5124**

Sheet No.: **A1.01**

Release: -

CHRISTIAN J. HILL

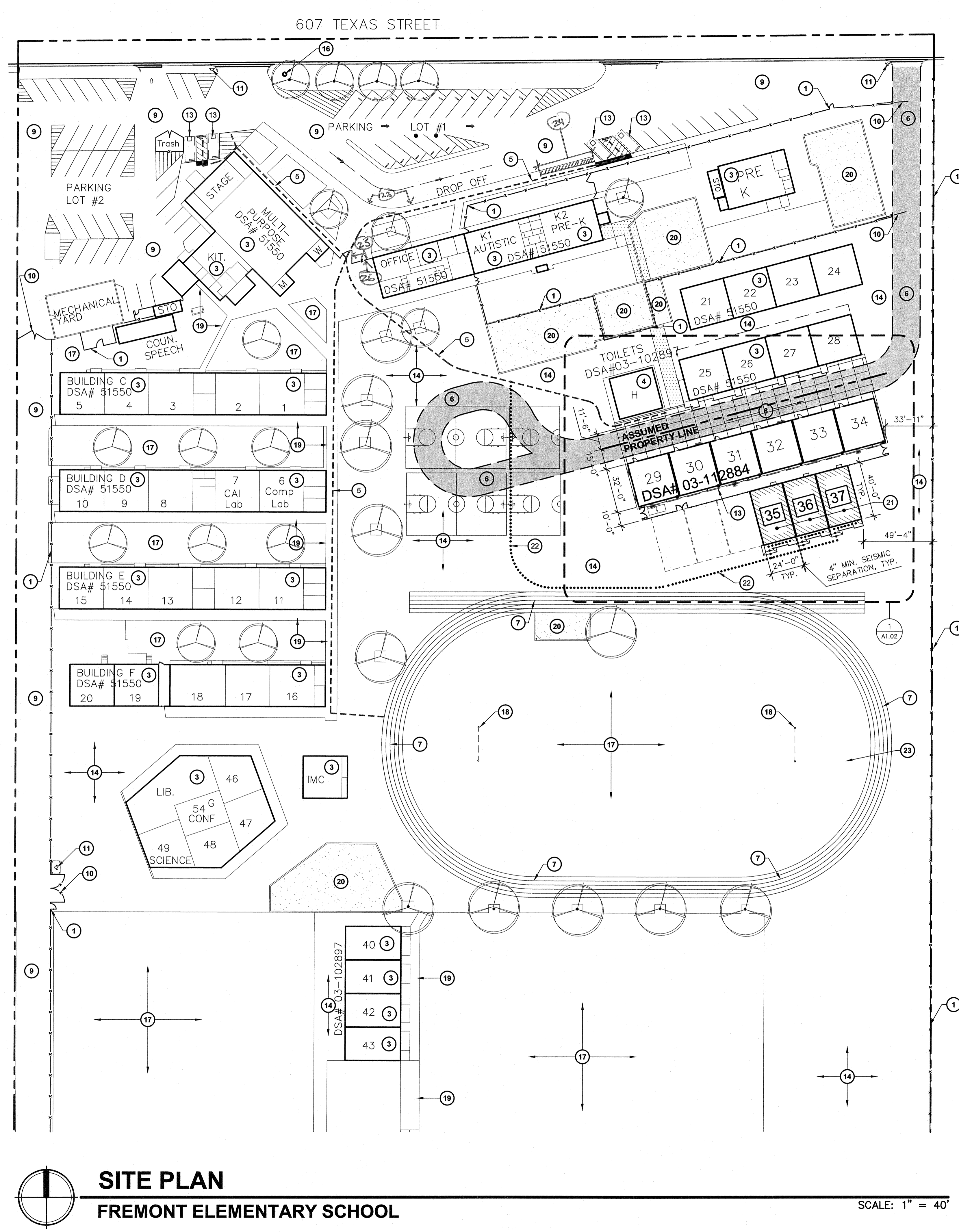
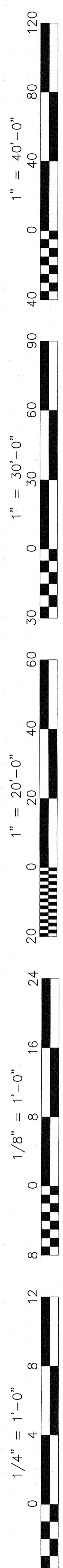

**SITE PLAN**  
**FREMONT ELEMENTARY SCHOOL**

SCALE: 1" = 40'

**GENERAL NOTES**

- A. GENERAL CONTRACTOR SHALL FIELD VERIFY ALL SITE CONDITIONS PRIOR TO BID. IF ANY DISCREPANCIES ARE FOUND, THE ARCHITECT SHALL BE NOTIFIED IN WRITING.
- B. CONTRACTOR SHALL BE RESPONSIBLE FOR THE CORRECTNESS OF LAYOUTS AND ESTABLISHING LOCATIONS OF BURIED UTILITY LINES. ANY UTILITIES REQUIRING RELOCATION SHALL BE THE RESPONSIBILITY OF THE GENERAL CONTRACTOR CONTACT APPLICABLE GOVERNING AGENCIES REGARDING ARRANGEMENT AND COORDINATION OF WORK.
- C. GENERAL CONTRACTOR WILL BE RESPONSIBLE FOR ANY COMPACTION RETEST DUE TO INITIAL FAILURE.
- D. PROJECT INSPECTOR SHALL BE EMPLOYED BY THE OWNER, APPROVED BY THE RESPONSIBLE ARCHITECT AND DSA.
- E. A COPY OF TITLE-24, ALL PARTS APPLICABLE, TO BE KEPT AT THE JOB SITE AT ALL TIMES.
- F. ADDENDA SHALL BE SIGNED BY THE ARCHITECT (RESPONSIBLE IN CHARGE) AND APPROVED BY DSA.
- G. C.C.D.s SHALL BE SIGNED BY THE ARCHITECT (RESPONSIBLE IN CHARGE), OWNER AND APPROVED BY DSA.
- H. TESTING LAB SHALL BE EMPLOYED BY THE OWNER, APPROVED BY THE RESPONSIBLE ARCHITECT AND DSA.
- I. ALL WORK SURFACES DISTURBED OR DAMAGED BY THE CONSTRUCTION ACTIVITIES SHALL BE REPAIRED IN KIND, TEXTURED AND FINISHED TO MATCH ADJACENT SURFACES.
- J. NEW CONCRETE WALKS SHALL HAVE SLOPES NOT TO EXCEED 1 IN 20 IN THE DIRECTION OF PATH OF TRAVEL. PROVIDE CONTROL JOINTS ("C.J.") AT 5'-0" O.C. MAX. AND EXPANSION JOINTS NOT TO EXCEED 30'-0" MAX. PROVIDE MEDIUM BROOM FINISH ON ALL WALKS.
- K. ALL BUILDING AND ROOM NAMES INDICATED ON THESE CONSTRUCTION DOCUMENTS ARE "NOT" THE ACTUAL BUILDING/ ROOM SIGNAGE DESIGNATION. THE GENERAL CONTRACTOR SHALL FURNISH, INSTALL AND COORDINATE ALL REQUIRED SIGNAGE WITH THE OWNER/ARCHITECT PRIOR TO STARTING CONSTRUCTION.
- L. GENERAL CONTRACTOR WILL BE RESPONSIBLE TO COORDINATE RELOCATABLE BUILDING DELIVERY DATES TO THE SCHOOL SITE WITH THE MFG.
- M. THE GENERAL CONTRACTOR SHALL CONSTRUCT ALL NEW RELOCATABLE BUILDING FOUNDATIONS AS PER THE RELOCATABLE BUILDING MANUFACTURER'S DRAWINGS AND SPECIFICATIONS.
- N. THE GENERAL CONTRACTOR SHALL BE RESPONSIBLE TO PROVIDE ALL HOOK-UPS TO THE RELOCATABLE BUILDINGS AFTER INSTALLATION HAS BEEN COMPLETED BY THE MANUFACTURER.
- O. 5'-0" DEEP x 5'-0" WIDE MINIMUM LANDINGS AT DOORWAYS SHALL BE AS DETAIL AND SHALL HAVE SLOPES (IN ANY DIRECTION) OF NOT GREATER THAN 1/4 IN 12 SLOPE. SLOPES SHALL BE AWAY FROM DOORWAYS.
- P. GENERAL/SITE CONTRACTOR SHALL FIELD VERIFY THAT EXISTING PATH OF TRAVEL (P.O.T.) IS A MINIMUM OF 4'-0" WIDE AND IS SLIP RESISTANT. IF IT IS NOT, THEN THE CONTRACTOR SHALL NOTIFY THE ARCHITECT OF RECORD AND A REMEDY OR ALTERNATE P.O.T. WILL BE PROVIDED.
- Q. THE MAXIMUM DROP BETWEEN EXISTING FINISHED GRADES AND THE TOP OF THE P.O.T. SHOULD NOT EXCEED 4". IF IT DOES, PROVIDE THE NECESSARY WARNING CURB PER CBC SEC. 11B-303.5.

24. PROVIDE NEW TRUNCATED DOWNS 3 FT WIDE ALONG THE LENGTH OF SIDEWALK THAT IS FLUSH WITH THE AC PAVING PER DETAIL 11/A1.03

25. EXISTING GATE TO REMAIN LOCKED IN THE OPEN POSITION DURING SCHOOL HOURS.

26. PROVIDE NEW 4 FT WIDE GATE PER 15 & 16 / A1.03

**LOCAL FIRE AUTHORITY REVIEW**

DSA #10 LOCAL FIRE AUTHORITY REVIEW

To facilitate the Division of the State Architect's (DSA) approval of the FireLife Safety portion of a project, DSA requires Local Fire Authority (LFA) review of certain elements as identified in this form. Use of this form is mandatory for projects that are subject to the jurisdiction of the State Fire Marshal or the State Fire Marshal's Office.

**PROJECT INFORMATION**

Project Name: FREMONT ELEMENTARY SCHOOL  
 Project Address: 607 TEXAS ST., BAKERSFIELD, CA 93307  
 LFA Agency Name: \_\_\_\_\_

**LOCAL FIRE AUTHORITY (LFA)**

LFA Reviewer Name: \_\_\_\_\_ Title: \_\_\_\_\_  
 Date: \_\_\_\_\_ Telephone: \_\_\_\_\_

I have reviewed and approved the applicable items for this project as listed below.  
 Note: Only sign this form on the left side of the page. The signature of the LFA Reviewer is required on the right side of the page.

Reviewer Key: "Y" = Complies with LFA Requirements; "N" = Not approved (complete item); "NA" = Not applicable to this project; "NR" = LFA unable to review

Description	Y	N	NA	NR
1. Where an elevator does not meet medical emergency service rules, use the California Building Code (CBC), use of stairways for emergency rescue and patient transport is acceptable.				
2. Access roads, fire lane markings, points and gate entrances are in accordance with Title 19, California Code of Regulations, & the California Fire Code, Chapter 1.				
3. Fire hydrant location and distribution complies with the California Fire Code (see 910).				
4. Fire hydrant location and distribution complies with NFPA 1142, "Minimum Means", "1" NCI" standard. DSA can only verify the location of hydrants. The signature of the school district official is required to acknowledge use of alternate means.				
5. Signature of School District Official: _____ Date: _____				
6. Print the School District Official's Name: _____				
7. The installation of the proposed fire alarm indicator valve and fire department connection meet the requirements of this jurisdiction.				
8. The backflow(s) of the detector check valve assembly meet the requirements of this jurisdiction.				
9. Is the project located in a hazard severity zone area? (CBC, Chapter 7A, Section 701A.)				
10. Check box "Y" for: <input type="checkbox"/> Moderate <input type="checkbox"/> High <input type="checkbox"/> Very High <input type="checkbox"/> NFPA (if one of these boxes is checked, the project design must meet the requirements of Chapter 7A.)				

COMMENTS (note deficiencies): \_\_\_\_\_

**KEYNOTES**

1. EXISTING CHAIN LINK FENCE AND GATE TO REMAIN
2. EXISTING ACCESSIBLE PARKING SIGNAGE, DSA# 03-102897, MOUNTED TO EXISTING C.L. FENCE
3. EXISTING BUILDING TO REMAIN, NO WORK
4. EXISTING ACCESSIBLE RESTROOM BUILDING PER DSA #03-102897, NO WORK
5. EXISTING ACCESSIBLE PATH OF TRAVEL TO REMAIN, VERIFY IN FIELD
6. EXISTING 20' WIDE FIRE TRUCK ACCESS LANE OVER EXISTING PAVING, APPROVED BY THE LOCAL JURISDICTION.
7. EXISTING TRACK STRIPING TO REMAIN
8. EXISTING CONCRETE WALK WITH MEDIUM BROOM FINISH
9. EXISTING A.C. PAVED PARKING LOT TO REMAIN
10. EXISTING 20' WIDE CHAIN LINK FIRE TRUCK ACCESS GATE. PROVIDE NEW KNOX PAD LOCK PER KERN COUNTY STANDARDS
11. EXISTING FIRE HYDRANT TO REMAIN
12. EXISTING PAIR OF 48" ACCESSIBLE GATES TO REMAIN LOCKED IN THE OPEN POSITION DURING SCHOOL HOURS
13. EXISTING ACCESSIBLE PARKING STALL PER DSA APPL. #03-112884
14. EXISTING A.C. PAVING TO REMAIN
15. PROVIDE 2" WIDE WHITE STRIPING WHERE REQUIRED TO MATCH WITH EXISTING TRACK CONFIGURATION WITHIN THE AREA OF THE NEW AC-PAVING
16. EXISTING TOW-AWAY SIGN MOUNTED TO EXISTING POLE PER DSA APPL. #03-112884
17. EXISTING TURF TO REMAIN, NO WORK
18. EXISTING GOAL POST TO REMAIN
19. EXISTING CONCRETE WALK TO REMAIN
20. EXISTING SAND BOX PLAY AREA TO REMAIN
21. NEW MODULAR CLASSROOM ON WOOD FOUNDATION w/ METAL RAMPS INSTALLED PER MANUFACTURER'S DRAWINGS
22. PROPOSED ACCESSIBLE PATH OF TRAVEL (P.O.T.) REFER TO ACCESSIBILITY NOTE, THIS SHEET

**PARKING CALCULATION**

**PARKING LOT #1**

TOTAL STALLS PROVIDED:	27
ACCESSIBLE STALLS REQUIRED PER CBC TABLE 11B-208.2:	2
VAN SPACES REQUIRED (1 PER 6 ADA):	1
ACCESSIBLE STALLS PROVIDED:	1 REGULAR 1 VAN 2 TOTAL

**PARKING LOT #2**

TOTAL STALLS PROVIDED:	37
ACCESSIBLE STALLS REQUIRED PER CBC TABLE 11B-208.2:	2
VAN SPACES REQUIRED (1 PER 6 ADA):	1
ACCESSIBLE STALLS PROVIDED:	1 REGULAR 1 VAN 2 TOTAL

**ACCESSIBILITY NOTES**

- ARCHITECT HAS INSPECTED THE PATH OF TRAVEL (P.O.T.) AS INDICATED ON THE PLANS AND HAS FOUND IT TO BE, OR HAS INDICATED ON THE PLANS REMEDIAL WORK WHICH WOULD CAUSE IT TO BE, A BARRIER-FREE ACCESSIBLE ROUTE.
- AT LEAST 48" IN WIDTH; OR AS APPROVED BY CODE
  - FREE OF ABRUPT LEVEL CHANGES EXCEEDING 1/4" IF BEVELED AT 1:2 MAX SLOPE, OR VERTICAL LEVEL CHANGES EXCEEDING 1/4"
  - WITH A FIRM, STABLE, AND SLIP RESISTANT WALKING SURFACE
  - WITH A RUNNING SLOPE OF 1:20 (5%) OR LESS AND WITH A CROSS SLOPE OF 1:50 (2%) OR LESS OR A RAMP WITH A RUNNING SLOPE OF 1:12 (8.33%) AND A CROSS SLOPE OF 1:50 (2%) WITH APPROPRIATE REQUIREMENTS AS DETAILED WITHIN THIS SET OF DOCUMENTS.
  - IS FREE OF OVERHEAD OBSTRUCTIONS WITHIN 80" ABOVE THE WALKING SURFACE
  - IS FREE OF OBJECTS WHICH PROTRUDE MORE THAN 4" BETWEEN THE HEIGHTS OF 27" AND 80" ABOVE THE WALKING SURFACE

**LEGEND**

- INDICATES EXISTING BUILDING TO REMAIN (NO WORK)
- INDICATES NEW PORTABLE BUILDING UNDER THIS APPLICATION
- INDICATES EXISTING FIRE TRUCK ACCESS OVER AC PAVING
- HALF-TONE DASHED LINE INDICATES EXISTING ACCESSIBLE PATH OF TRAVEL
- INDICATES PROPOSED ACCESSIBLE PATH OF TRAVEL, THIS APPLICATION

Ownership of Documents  
 This document, the ideas and designs incorporated herein, as an instrument of Professional Service is the property of Integrated Designs by SOMAM Inc. and is not to be used, in whole or in part for any other project without written authorization.  
 © COPYRIGHT 2014

**integrated designs** by SOMAM, Inc.  
 ARCHITECTURE • INTERIOR DESIGN • CONSTRUCTION MANAGEMENT  
 8011 N. Fresno, Suite 130 - Fresno, California 93710  
 Phone (569) 438-0881 Fax (569) 438-0887 E-Mail: design@somam.com  
 www.integrateddesigns.com

Revision	Description	Rev. Date	Rev. By

Sheet Title: **SITE PLAN**  
 FIRE MARSHAL APPROVED  
**3 RELOCATABLE CLASSROOMS**  
**FREMONT ELEMENTARY SCHOOL**  
 BAKERSFIELD CITY SCHOOL DISTRICT  
 607 TEXAS ST., BAKERSFIELD, CA 93307

Sheet No.: **A1.01**  
 Release: **FMA**

Design Date: 05/27/14  
 Date: 05/20/14  
 Designer: \_\_\_\_\_  
 Checker: \_\_\_\_\_  
 P.C.: C/JH

Agency Approval Stamp:

IDENTIFICATION STAMP  
 DIV. OF THE STATE ARCHITECT  
 APPROVED 116890  
 ARCHITECT: \_\_\_\_\_  
 DATE: 7/21/14

Stamp(s):

Job No.: **5124**  
 Sheet No.: **A1.01**  
 Release: **FMA**

Scale: 1" = 40'

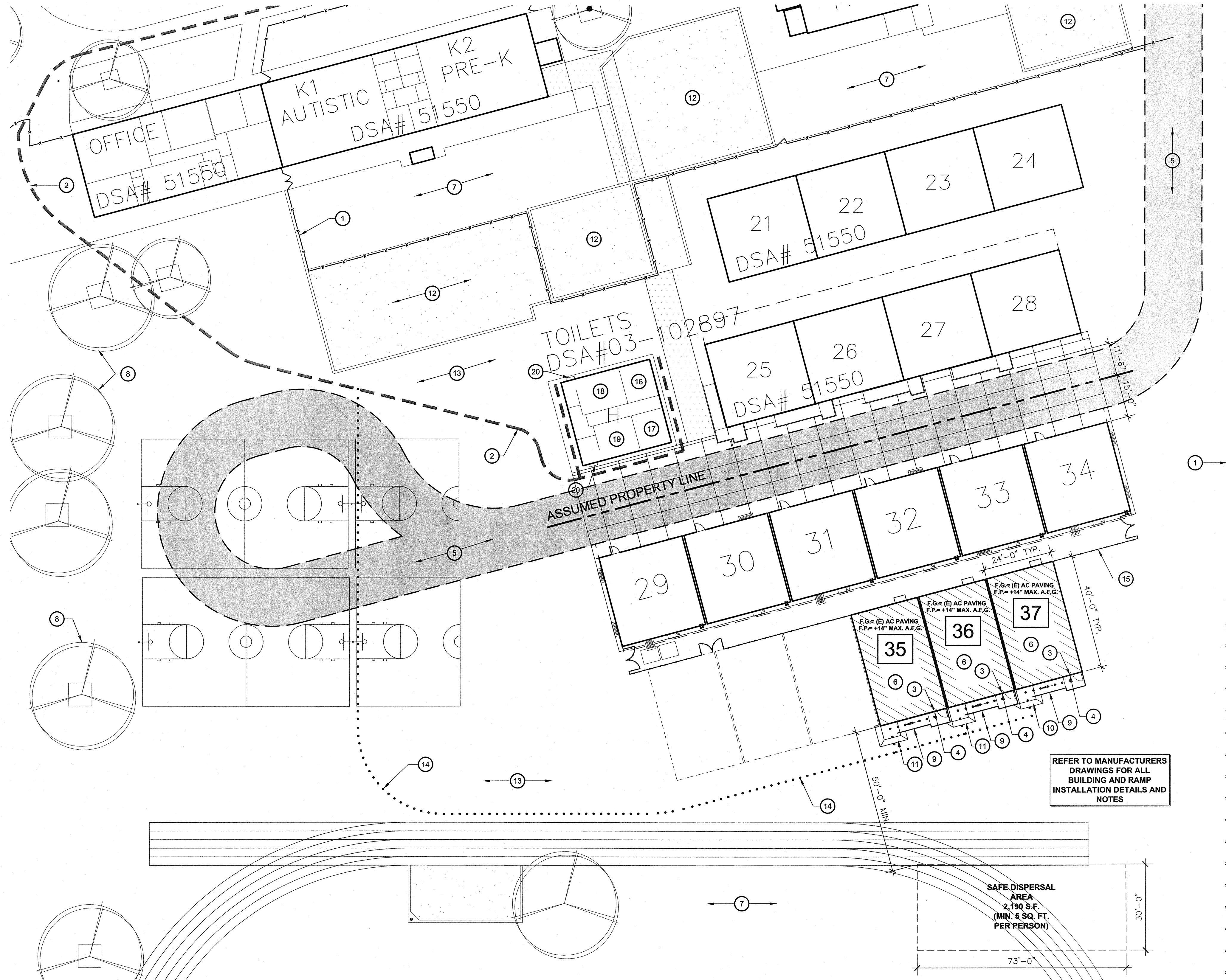
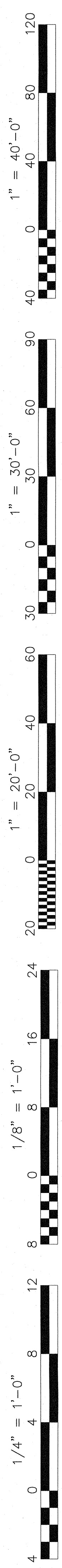

**ENLARGED SITE PLAN**  
**FREMONT ELEMENTARY SCHOOL**

SCALE: 1" = 20'

**KEY NOTES**

1. EXISTING CHAIN LINK FENCE AND GATE TO REMAIN
2. EXISTING ACCESSIBLE PATH OF TRAVEL, VERIFY IN FIELD FOR COMPLIANCE
3. NEW TACTILE EXIT SIGN PER DETAIL 2/A1.03
4. NEW ROOM IDENTIFICATION AND ISA SIGNAGE, REFER TO DETAILS 3, 4/A1.03
5. EXISTING 20' WIDE FIRE TRUCK ACCESS LANE OVER EXISTING AC PAVING, APPROVED BY THE LOCAL JURISDICTION.
6. NEW TEMPORARY PORTABLE BUILDINGS ON RAISED WOOD FOUNDATIONS WITH METAL RAMP SUPPLIED BY MANUFACTURER, OWNER TO REMOVE ALL INTERFERING PLAY EQUIPMENT
7. EXISTING LANDSCAPE AREA TO REMAIN, NO WORK
8. EXISTING TREE AND PLANTER TO REMAIN
9. METAL RAMP PER 2/R1.0 OR 2/R1.00
10. RAMP TRANSITION PER 18/R1.02
11. RAMP TRANSITION PER 19/R2.0
12. EXISTING SAND BOX PLAY AREA TO REMAIN, NO WORK
13. EXISTING A.C. PAVING TO REMAIN, NO WORK
14. PROPOSED ACCESSIBLE PATH OF TRAVEL PER THIS APPLICATION. SEE ACCESSIBILITY NOTES, SHEET A1.01
15. EXISTING CHAIN LINK MECHANICAL ENCLOSURE TO REMAIN. REMOVE PORTION OF FENCING AT NEW PORTABLE LOCATIONS
16. EXISTING MENS RESTROOM PER DSA APPL. NO. 03-102897
17. EXISTING WOMENS RESTROOM PER DSA APPL. NO. 03-102897
18. EXISTING BOYS RESTROOM PER DSA APPL. NO. 03-102897
19. EXISTING GIRLS RESTROOM PER DSA APPL. NO. 03-102897
20. EXISTING ACCESSIBLE DRINKING FOUNTAIN PER DSA APPL. NO. 03-102897

**GENERAL NOTES**

A. DETERIORATION OR EXISTING NON-COMPLIANT CONSTRUCTION:  
IF ANY CONDITION IS DISCOVERED WHICH, IF LEFT UNCORRECTED, WOULD MAKE THE BUILDING NON-COMPLIANT WITH THE REQUIREMENTS OF THE EDITION OF THE CBC IN FORCE AT THE TIME OF ORIGINAL CONSTRUCTION, THE CONDITION MUST BE CORRECTED IN ACCORDANCE WITH CURRENT CODE REQUIREMENTS. A C.C.D. OR A SEPARATE SET OF PLANS AND SPECIFICATIONS DETAILING AND SPECIFYING THE REQUIRED REPAIR WORK SHALL BE SUBMITTED TO AND APPROVED BY DSA BEFORE PROCEEDING WITH THE REPAIR WORK.  
\*PER DSA IR 16-1, SEC. 5.4

B. CONTRACTOR SHALL ADJUST ALL DOOR CLOSERS TO A MAXIMUM OPENING FORCE OF 5 LBF

**SERIAL NUMBER SCHEDULE**

CLS#	STKP #	SERIAL #
35	66341 (109)	23133 / 23134
36	66341 (109)	29914 / 29915
37	04-101984 (111)	44997 / 44998

**SAFE DISPERSAL**

**TEMP CLASSROOMS**  
6 (E) CLASSROOMS @ 960 S.F. (30'x32') EA. = 5,760 S.F.  
3 (N) CLASSROOMS @ 960 S.F. (24'x40') EA. = 2,880 S.F.  
TOTAL = 8,640 S.F.

8,640 S.F. / 20 S.F. PER OCCUPANT = 432 OCCUPANTS  
432 OCCUPANTS x 5 S.F. / OCCUPANT = 2,160 S.F. REQ'D  
2,190 S.F. PROVIDED = OK

**LEGEND**

- INDICATES EXISTING BUILDING TO REMAIN (NO WORK)
- INDICATES NEW TEMPORARY RELOCATABLE BUILDING
- HALF-TONE DASHED LINE INDICATES EXISTING ACCESSIBLE PATH OF TRAVEL
- INDICATES NEW ACCESSIBLE PATH OF TRAVEL PER THIS APPLICATION

**Ownership of Documents**  
This document, the ideas and designs incorporated herein, as an instrument of Professional Service is the property of Integrated Designs by SOMAM, Inc. and is not to be used, in whole or in part for any other project without written authorization.  
© COPYRIGHT 2014

**integrated designs** by SOMAM, Inc.  
ARCHITECTURE · INTERIOR DESIGN · CONSTRUCTION MANAGEMENT  
8011 N. Fresno, Suite 130 - Fresno, California 93710  
Phone (559) 439-0881 Fax (559) 439-0887 E-Mail: design@somam.com  
www.integrateddesigns.com

Revision	Description	Rev. Date

**ENLARGED SITE PLAN**

**3 RELOCATABLE CLASSROOMS**  
**FREMONT ELEMENTARY SCHOOL**  
BAKERSFIELD CITY SCHOOL DISTRICT  
607 TEXAS ST. BAKERSFIELD, CA 93307

Sheet Title: ENLARGED SITE PLAN  
Issue Date: 05/27/14  
Date: 06/19/14  
Designer: [Signature]  
DR: [Signature]  
PC: C/JH

Agency Approval Stamp:

IDENTIFICATION STAMP  
DIV. OF THE STATE ARCHITECT  
APPROVED 115090  
AC [Signature] FILED [Signature] DB  
DATE 7/24/14

Stamp(s):

Job No.: **5124**

Sheet No.: **A1.02**

Release: -



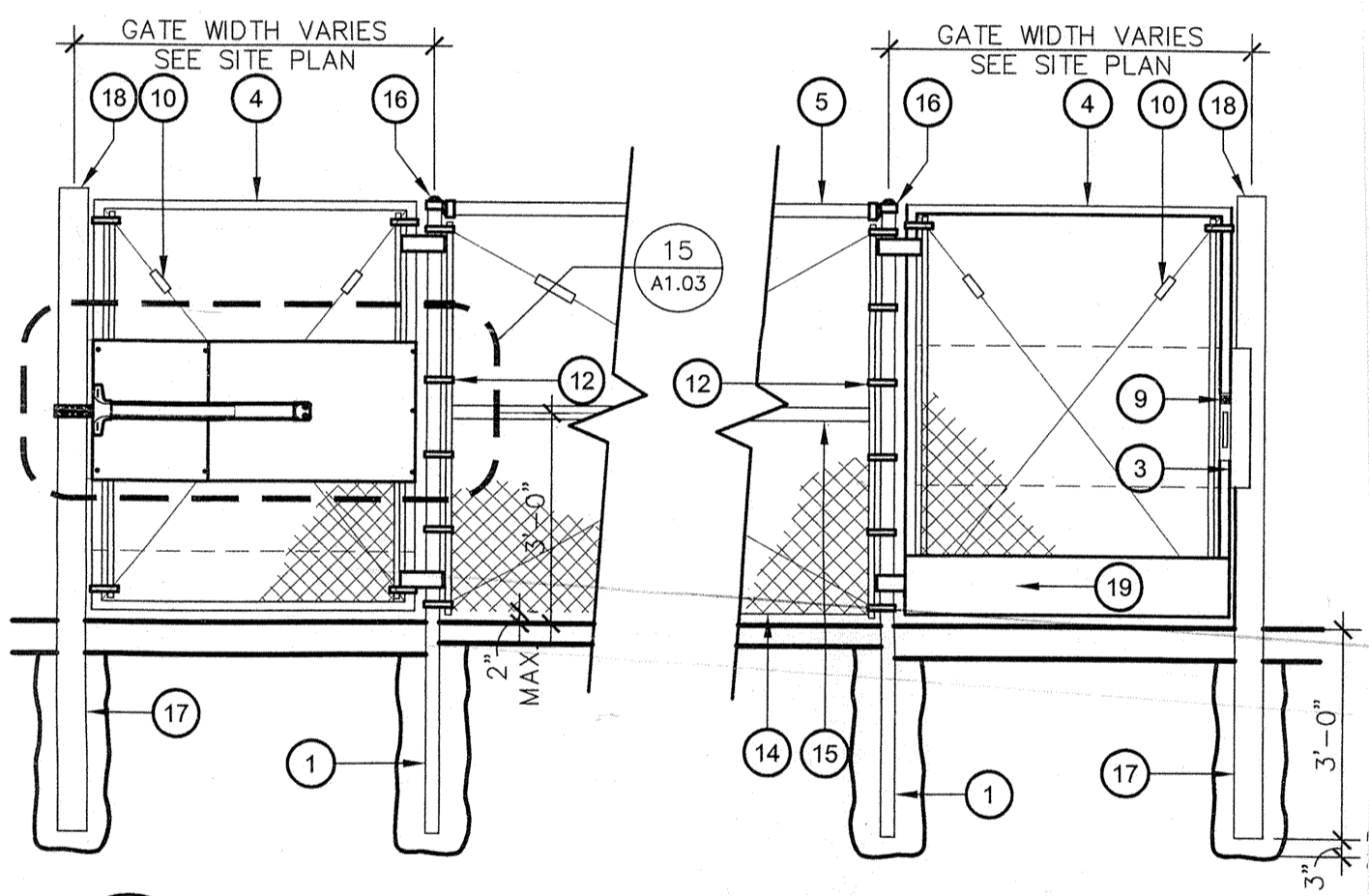
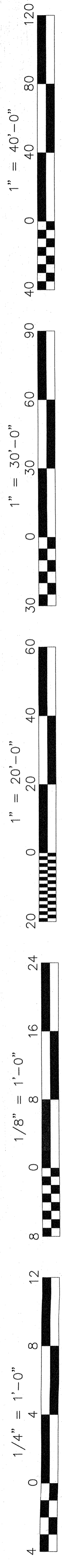

**16 ACCESSIBLE ENTRY GATE AND TYPICAL 6' FENCE**  
 A1.03 ADY100-06 SCALE: N.T.S.

- FENCE ITEMS TO BE FURNISHED & INSTALLED**
- 4" O.D. GALVANIZED STEEL GATE POST (9.1 lb/ft)
  - 180° HINGE (TYP. FOR 4)
  - 16ga GATE GUARD, SEE 15/A1.03
  - 2" O.D. GALVANIZED STEEL GATE FRAME (2.72 lb/ft) (2"x2" TUBE AT SINGLE ENTRY MAN-GATES)
  - 5/8" O.D. GALVANIZED STEEL HORIZONTAL RAIL (2.27 lb/ft)
  - 2"x2" MESH x 9 GAUGE GALVANIZED FENCE FABRIC WITH KNUCKLED TOP AND BOTTOM SELVAGE. FENCE FABRIC TO BE GALVANIZED BEFORE WEAVING (GBW)
  - 1/4"x3/4" GALVANIZED STEEL STRETCHER BAR
  - 9 GAUGE (0.148" DIA.) GALVANIZED STEEL-TIE WIRES OR HOG RINGS AT 15" MAX. SPACING. MIN. 8 TIE WIRES PER EACH 10" HORIZONTAL RAIL
  - TRIM, TUBULAR HANDLE & RIM CYLINDER LOCK PER DISTRICT STANDARD
  - GALVANIZED ADJUSTABLE TURNBUCKLE FOR 3/8" DIA. TRUSS ROD
  - 3/8" DIA. GALVANIZED STEEL ADJUSTABLE TRUSS ROD. TRUSS RODS REQUIRED FOR ALL GATE POST PANELS AND END OR CORNER POST PANELS
  - GALVANIZED STEEL STRETCHER BAR TENSION BAND AT 12" MAX. SPACING. MIN. OF 12 TENSION BANDS FOR 12'-0" POST; MIN. OF 6 TENSION BANDS FOR 6'-0" POSTS
  - 3/8"x6" GALVANIZED HOOK BOLT WITH NUT IMBEDDED IN MOWSTRIP MIDWAY BETWEEN POSTS
  - 7 GAUGE (0.177" DIA.) GALVANIZED STEEL TENSION WIRE
  - 5/8" O.D. GALVANIZED STEEL HORIZONTAL RAIL TO BE ADDED TO 6'-0" HIGH CHAIN LINK FENCE AROUND KINDERGARTEN PLAY AREA ONLY AND AT END OF BASKETBALL COURTS
  - RAINPROOF CAP
  - 4"x4"x3/16" H.S.S.
  - 3/16" CAP R W/ 3/16" FILLET WELD, GRIND SMOOTH
  - POWDER COATED FINISH OVER ELECTRO-GALVANIZED 10"x GATE WIDTH, 16ga MTL. PLATE (SILVER). BOTH SIDES OF EACH GATE.
  - 5-1/2" THICK CONCRETE MOWSTRIP AT GATE OPENING
  - CLASS B CONCRETE POST FOOTING (TYP.)

**NOTES:**  
 1. CONTRACTOR TO PROVIDE AND INSTALL GATE HOLD BACK FOR EACH DRIVE GATE. HOLD BACK TO BE INSTALLED IN FENCE MOWSTRIP, UNLESS OTHERWISE SHOWN.

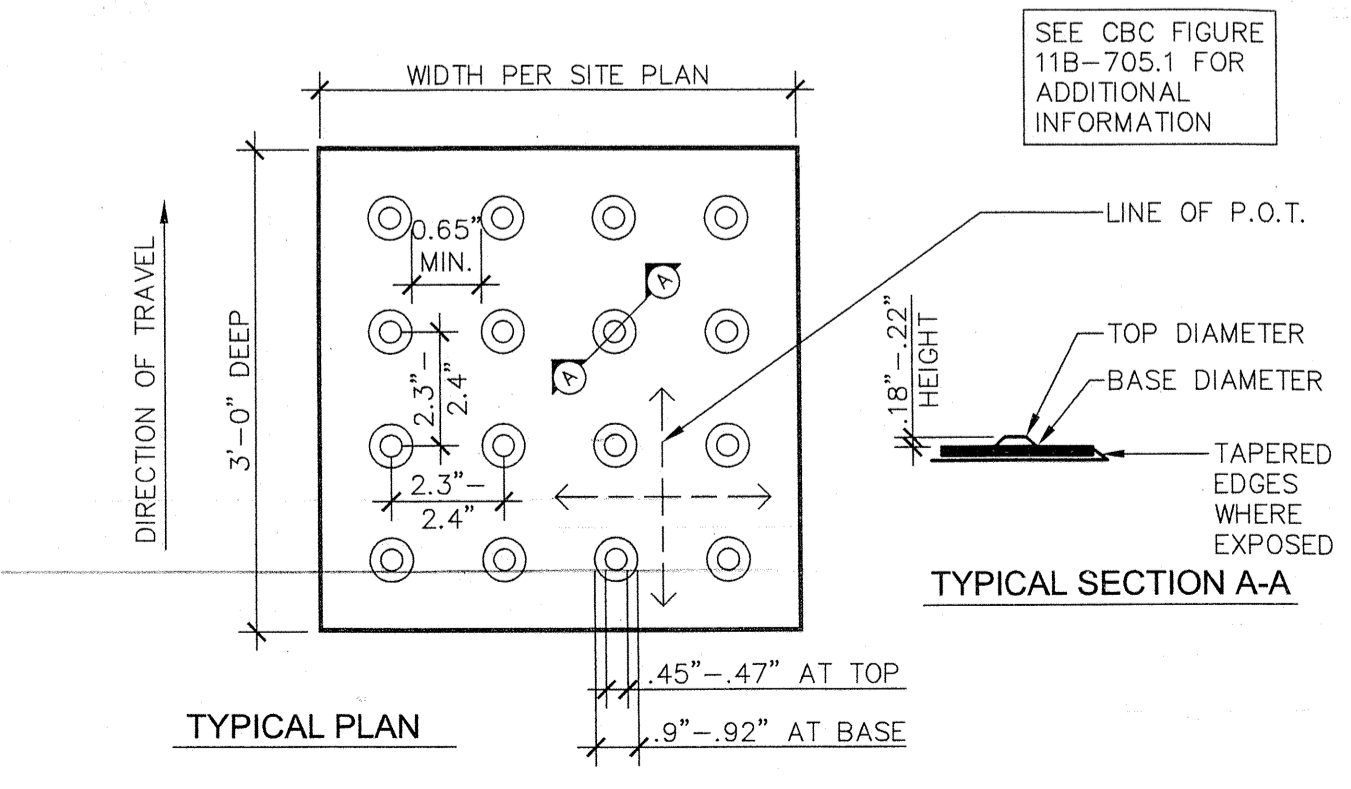

**11 TRUNCATED DOMES**  
 A1.03 ADA100-23 SCALE: NO SCALE

**15 PANIC DOOR HARDWARE**  
 A1.03 ADY100-02 SCALE: 1 1/2" = 1'-0"

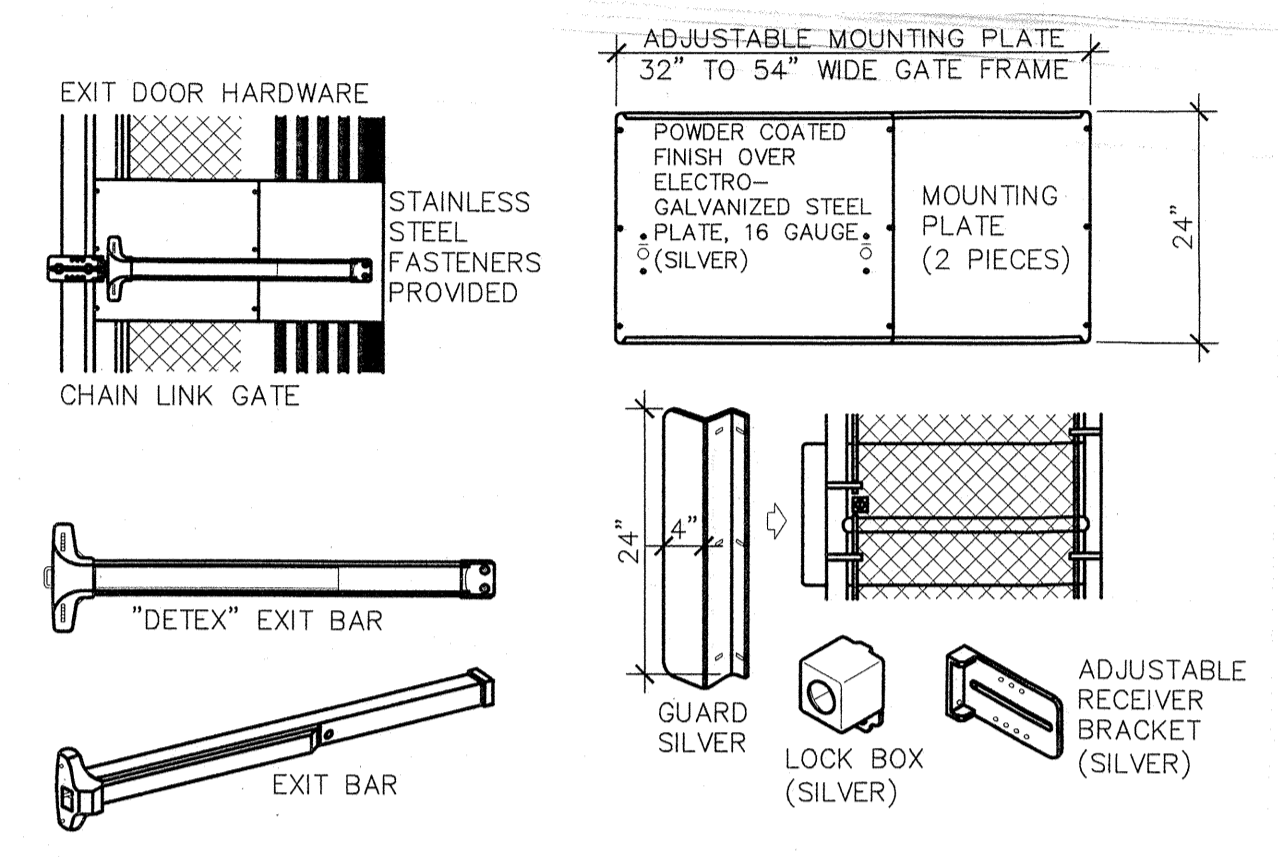

- NOTES:**
- DOOR SIGNS TO BE CONSTRUCTED FROM 1/4" THICK PLASTIC OR HEAT STAMPED FIGURES. COLORS TO BE SELECTED BY ARCHITECT.
  - ATTACH SIGNS USING FOUR (4) FLATHEAD, STAINLESS STEEL, TAMPER PROOF SCREWS, (COUNTERSUNK) AND ADHESIVE.
  - 70% CONTRAST BETWEEN CHARACTERS AND BACKGROUND

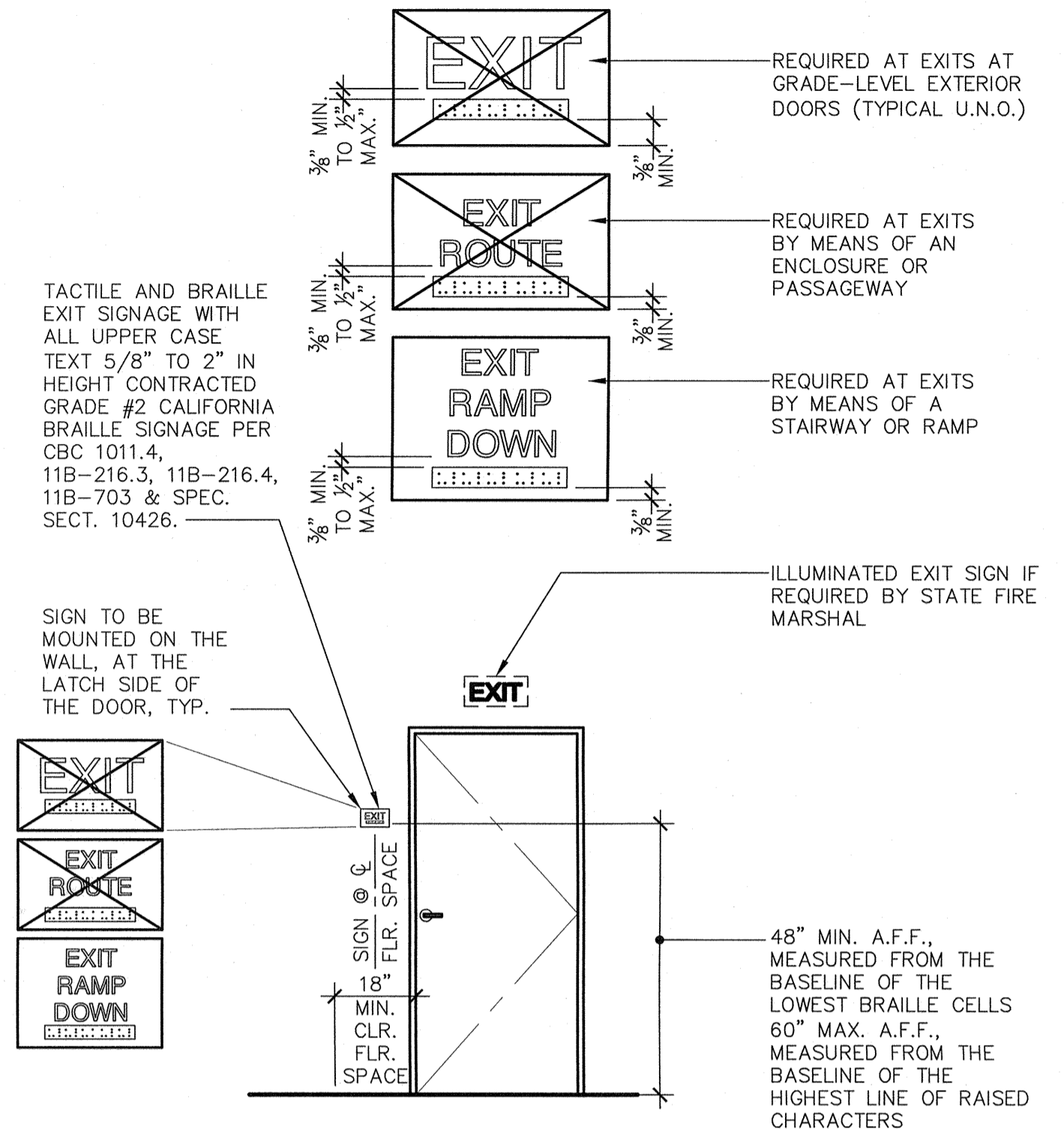

**2 TYPICAL EXTERIOR DOOR SIGNAGE**  
 A1.03 ADX200-01 SCALE: 3/8" = 1'-0"

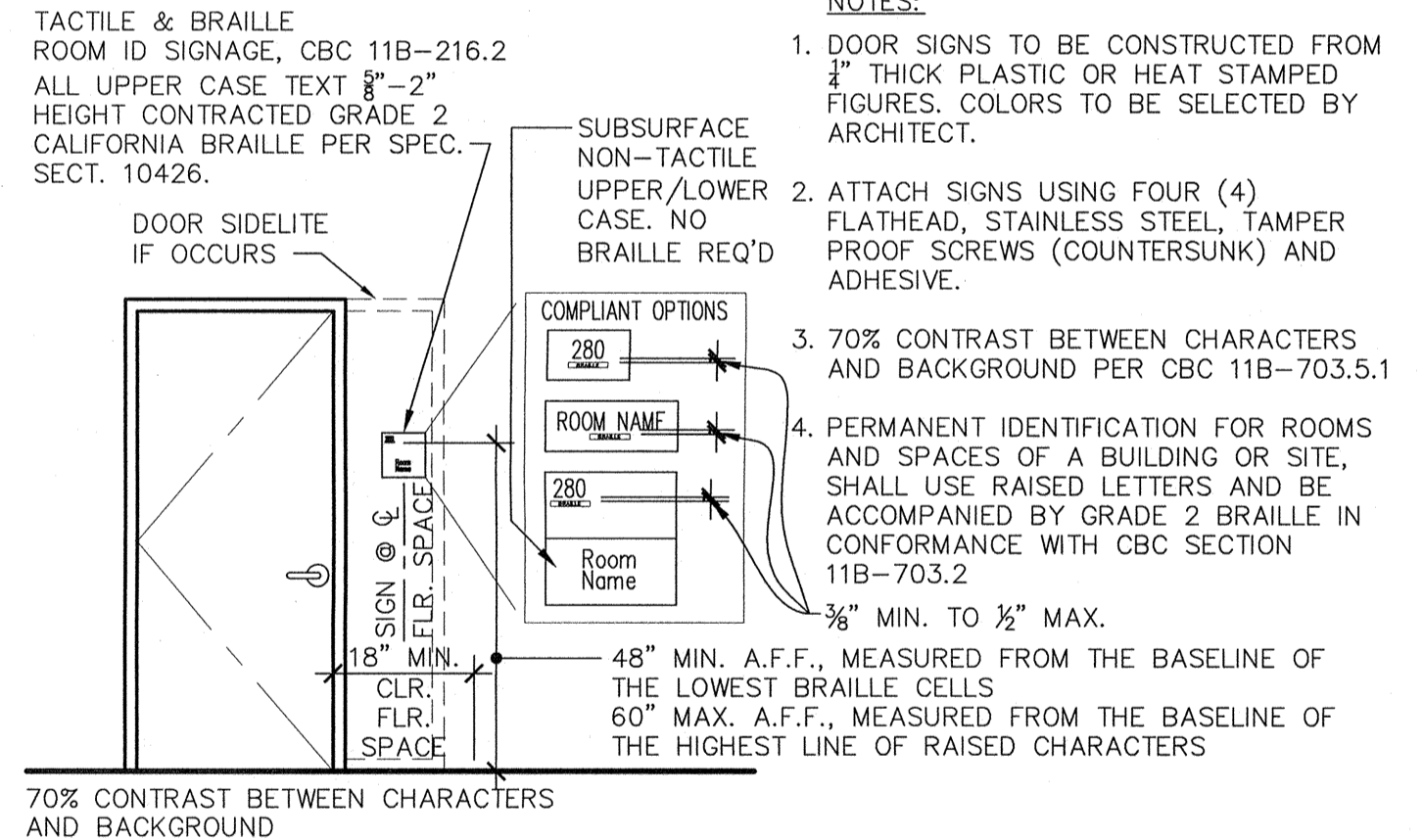

**3 ROOM ID SIGNAGE**  
 A1.03 ADX100-01 SCALE: NO SCALE

- NOTES:**
- DOOR SIGNS TO BE CONSTRUCTED FROM 1/4" THICK PLASTIC OR HEAT STAMPED FIGURES. COLORS TO BE SELECTED BY ARCHITECT.
  - ATTACH SIGNS USING FOUR (4) FLATHEAD, STAINLESS STEEL, TAMPER PROOF SCREWS (COUNTERSUNK) AND ADHESIVE.
  - 70% CONTRAST BETWEEN CHARACTERS AND BACKGROUND PER CBC 11B-703.5.1.
  - ISA SYMBOL CAN ALSO BE PLACED ON DOOR. THE LOCATION IS NOT REGULATED.

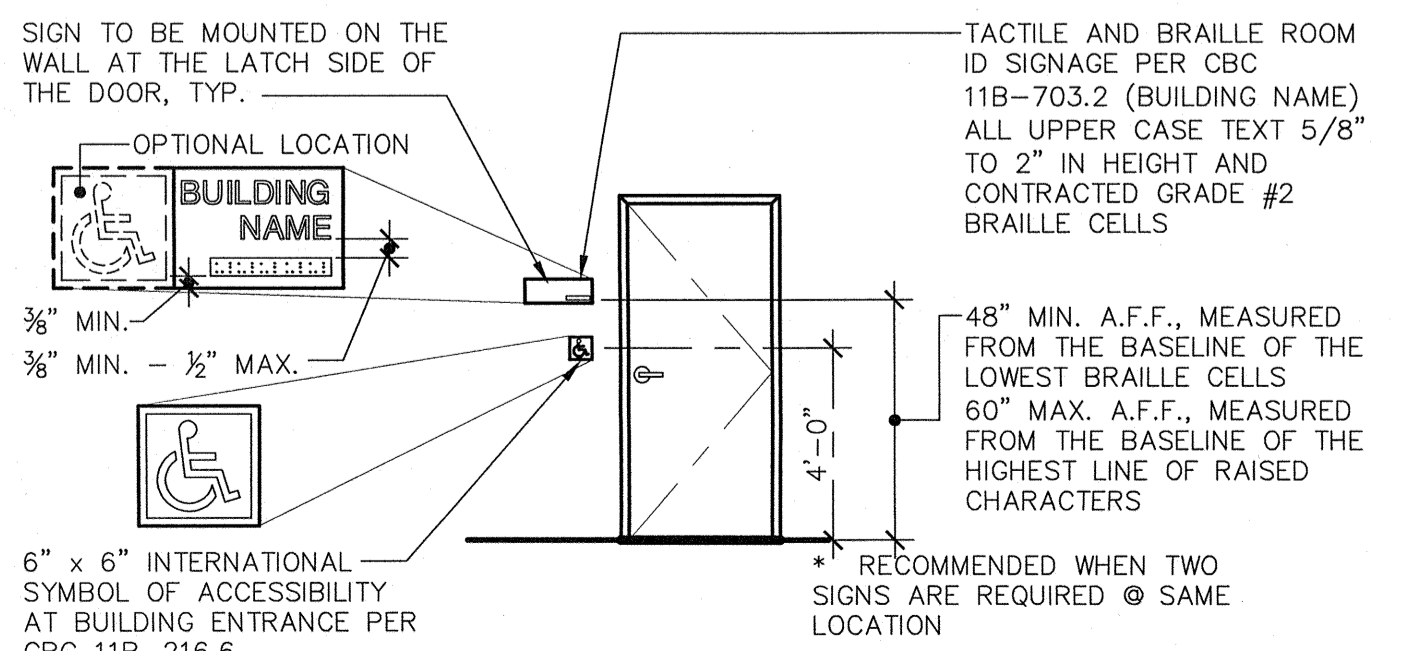

**4 BUILDING ENTRANCE/I.S.A. SIGNAGE**  
 A1.03 ADA100-01 SCALE: 1/4" = 1'-0"

Ownership of Documents  
 This document, the ideas and designs incorporated herein, as an instrument of Professional Service is the property of Integrated Designs by SOMAM, Inc. and is not to be used, in whole or in part for any other project without written authorization.  
 © COPYRIGHT 2014

**integrated designs** by SOMAM, Inc.  
 ARCHITECTURE - INTERIOR DESIGN - CONSTRUCTION MANAGEMENT  
 8011 N. Fresno, Suite 130 - Fresno, California 93710  
 Phone (559) 430-0881 Fax (559) 430-0887 E-Mail: design@somam.com  
 www.integrateddesigns.com

Project Name & Address:  
**3 RELOCATABLE CLASSROOMS  
 FREMONT ELEMENTARY SCHOOL**  
 BAKERSFIELD CITY SCHOOL DISTRICT  
 607 TEXAS ST., BAKERSFIELD, CA 93307

Issue Date: 05/27/14  
 Date: 06/19/14  
 Designer: [Signature]  
 DR: [Signature]  
 PC: CUH

Agency Approval Stamp:  
 IDENTIFICATION STAMP  
 DIV OF THE STATE ARCHITECT  
 APPROX 116600  
 AC: [Signature]  
 DS: [Signature]  
 7/24/14

Stamp(s):  
 LICENSED ARCHITECT  
 CHRISTIAN J. HILL  
 No. C 2866  
 Exp. 5-31-15  
 STATE OF CALIFORNIA

Job No: **5124**  
 Sheet No: **A1.03**  
 Release: -

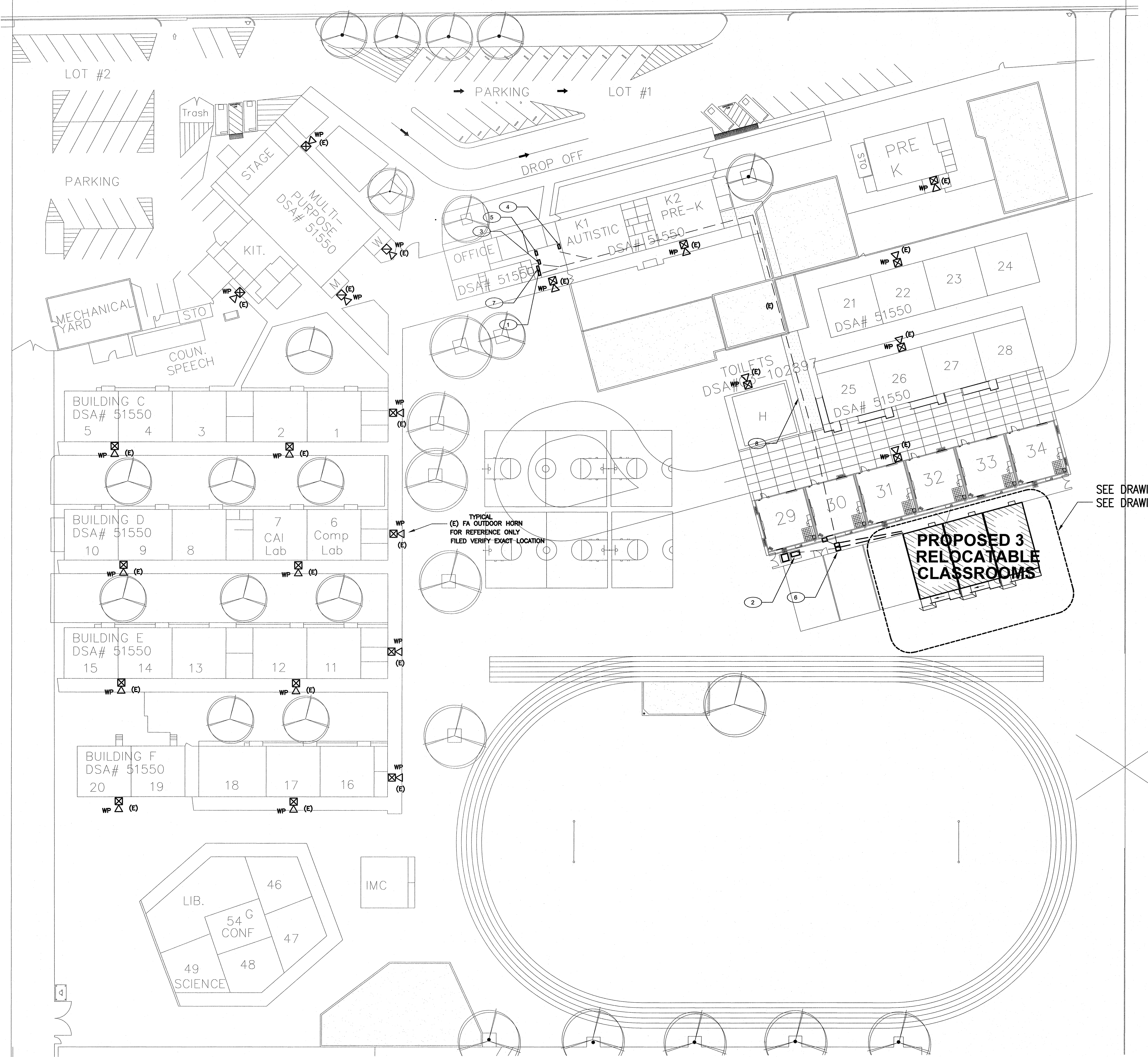
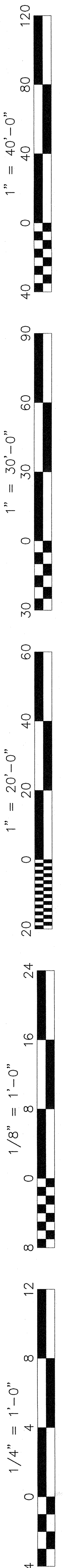

# SHEET NOTES

- 1 APPROXIMATE LOCATION FOR EXISTING ADDRESSABLE FIRE ALARM CONTROL PANEL TO REMAIN IN SERVICE. PROVIDE CONNECTION TO NEW FIRE ALARM DEVICES PER PLANS. UPDATE NEW FIRE ZONE MAP AND PROGRAM NEW DEVICES INFORMATION. MEASURE ACTUAL LOAD CURRENT AND VOLTAGE DROP FOR EACH INAC SIGNAL CIRCUITS, AND FACP STANDBY CURRENT AND ALARM CURRENT. SEND THE REPORT TO OWNER AND ENGINEER FOR REVIEW, AND PLASTIC LAMINATED ONE COPY INSIDE FACP CABINET DOOR.
- 2 APPROXIMATE LOCATION FOR EXISTING DISTRIBUTION PANEL H. PROVIDE NEW BREAKERS, FEEDERS AND POWER CONNECTION FOR NEW RELOCATABLE CLASSROOM BUILDINGS PER PLANS. SEE SINGLE LINE DIAGRAM.
- 3 APPROXIMATE LOCATION FOR EXISTING P.A./C/TELEPHONE EQUIPMENT IN ADMIN OFFICE. PROVIDE NEW CABLE AND CONNECTION FOR NEW SIGNAL DEVICES PER PLANS.
- 4 APPROXIMATE LOCATION FOR EXISTING COMPUTER MUX SERVER EQUIPMENT IN ADMIN OFFICE. PROVIDE NEW CABLE AND CONNECTION FOR NEW SIGNAL DEVICES PER PLANS.
- 5 APPROXIMATE LOCATION FOR EXISTING MASTER INTRUSION ALARM EQUIPMENT IN ADMIN OFFICE. PROVIDE NEW CABLE AND CONNECTION FOR NEW SIGNAL DEVICES PER PLANS.
- 6 (E) SIGNAL AND POWER PULL BOXES. EXTEND NEW I/LG CONDUITS AND WIRING TO NEW BUILDINGS PER PLANS. SEE RISER DIAGRAMS.
- 7 FURNISH AND INSTALL A NEW FIRE ALARM DIGITAL VOICE COMMAND CENTER AND INTER CONNECT TO EXISTING FIRE ALARM CONTROL PANEL. SURFACE MOUNT NEXT TO (E) FACE. FILED VERIFY EXACT LOCATION. SEE FA DRAWING E-3 RISER DIAGRAM.
- 8 APPROXIMATE LOCATION AND ROUTING FOR EXISTING SIGNAL CONDUITS. FILL IN NEW CONDUCTORS PER PLANS. FILED VERIFY LOCATION AND SEE RISER DIAGRAMS.

(E) --- INDICATE EXISTING CONDUIT AND WIRING. FOR REFERENCE ONLY. FIELD VERIFY AS REQUIRED.

SEE DRAWING E-2 FOR POWER AND SIGNAL  
SEE DRAWING E-3 FOR FIRE ALARM

**CODE RULES AND REGULATIONS**  
 ALL WORK AND MATERIAL SHALL BE IN FULL ACCORDANCE WITH THE LATEST RULES AND REGULATIONS OF THE STATE FIRE MARSHAL, THE CALIFORNIA ELECTRICAL CODE; THE SAFETY ORDERS OF THE DIVISION OF INDUSTRIAL SAFETY AND OTHER APPLICABLE STATE LAWS OR REGULATIONS. NOTHING IN THESE PLANS OR SPECIFICATIONS IS TO BE CONSTRUED TO PERMIT WORK NOT CONFORMING TO THESE CODES.  
 DIVISION OF THE STATE ARCHITECT APPLICABLE CODES AND STANDARDS:  
 2007 CALIFORNIA ELECTRIC CODE (CEC).  
 2007 CALIFORNIA FIRE CODE (CFC).  
 2007 TITLE 19 (CCR), PUBLIC SAFETY, STATE FIRE MARSHAL  
 2002 NFPA 72 (CALIFORNIA AMENDED) - NATIONAL FIRE ALARM CODES. POLICY #95-03, FIRE AND LIFE SAFETY, DIVISION OF THE STATE ARCHITECT OFFICE OF REGULATION SERVICES.

**REGULATIONS UNDERGROUND SERVICE ALERT**  
 CALL BEFORE YOU DIG: 1-800-642-2444  
 THE LOCATION OF EXISTING UNDERGROUND UTILITIES WERE TAKEN FROM SOURCES BELIEVED TO BE RELIABLE. HOWEVER, THEY HAVE NOT BEEN INDEPENDENTLY VERIFIED BY THE OWNER OR THIS ENGINEER. THE CONTRACTORS SHALL DETERMINE THE EXACT LOCATION OF ALL EXISTING UTILITIES BEFORE COMMENCING WORK, AND AGREE TO BE FULLY RESPONSIBLE FOR ANY AND ALL DAMAGES WHICH MIGHT BE OCCASIONED BY THE CONTRACTOR'S FAILURE TO EXACTLY LOCATE AND PRESERVE ANY AND ALL UNDERGROUND UTILITIES.  
 NOTIFY OWNER 72 HOURS PRIOR TO ANY EXCAVATION

CONSULTING ENGINEERS  
**JOHN CHONG ENGINEERING**  
 JOHN S. CHONG  
 E 14419  
 Exp. 8/30/2016  
 ELECTRICAL  
 REGISTERED PROFESSIONAL ENGINEER  
 STATE OF CALIFORNIA  
 2017 E. DECATUR AVE. FRESNO CA 93710  
 (509) 215-9266 • FAX 207-944  
 jchong1neer@aol.com

Ownership of Documents  
 This document, the ideas and designs incorporated herein, as an instrument of Professional Service is the property of Integrated Designs by SOMAM Inc. and is not to be used, in whole or in part for any other project without written authorization.  
 © COPYRIGHT 2013

**integrated designs** by SOMAM, Inc.  
 ARCHITECTURE - ENGINEERING - INTERIOR DESIGN - CONSTRUCTION MANAGEMENT  
 6011 N. Fresno, Suite 130 - Fresno, California 93710  
 Phone (559) 435-0881 Fax (559) 435-0887 E-Mail: design@somam.com  
 www.integrateddesigns.com

Rev. No.	Rev. Date	Rev. Description

Sheet Title: **SITE PLAN - ELECTRICAL**

Project Name & Address:  
**FREMONT ELEMENTARY SCHOOL**  
**3 RELOCATABLE CLASSROOMS**  
 BAKERSFIELD CITY SCHOOL DISTRICT  
 607 TEXAS STREET, BAKERSFIELD, CA

Issue Date:	00/00/14
Date:	05/28/14
Designer:	J CHONG
DR:	J CHONG
PC:	CJM

Agency Approval Stamp:

FILE #: 15-6  
 IDENTIFICATION STAMP  
 DIV. OF THE STATE ARCHITECT  
 OFFICE OF REGULATION SERVICES  
 115890  
 AC: JVC FLS: SS: JB  
 DATE: 7/24/14  
 TRACKING #: DSA TRACKING NO.

Stamp(s):

Job No.: **5124**

Sheet No.: **E-1**

Release: 7/8/2014 8:24:42 AM

**SITE PLAN - ELECTRICAL**  
**3 RELOCATABLE CLASSROOM**  
 SCALE : 1" = 30' - 0"

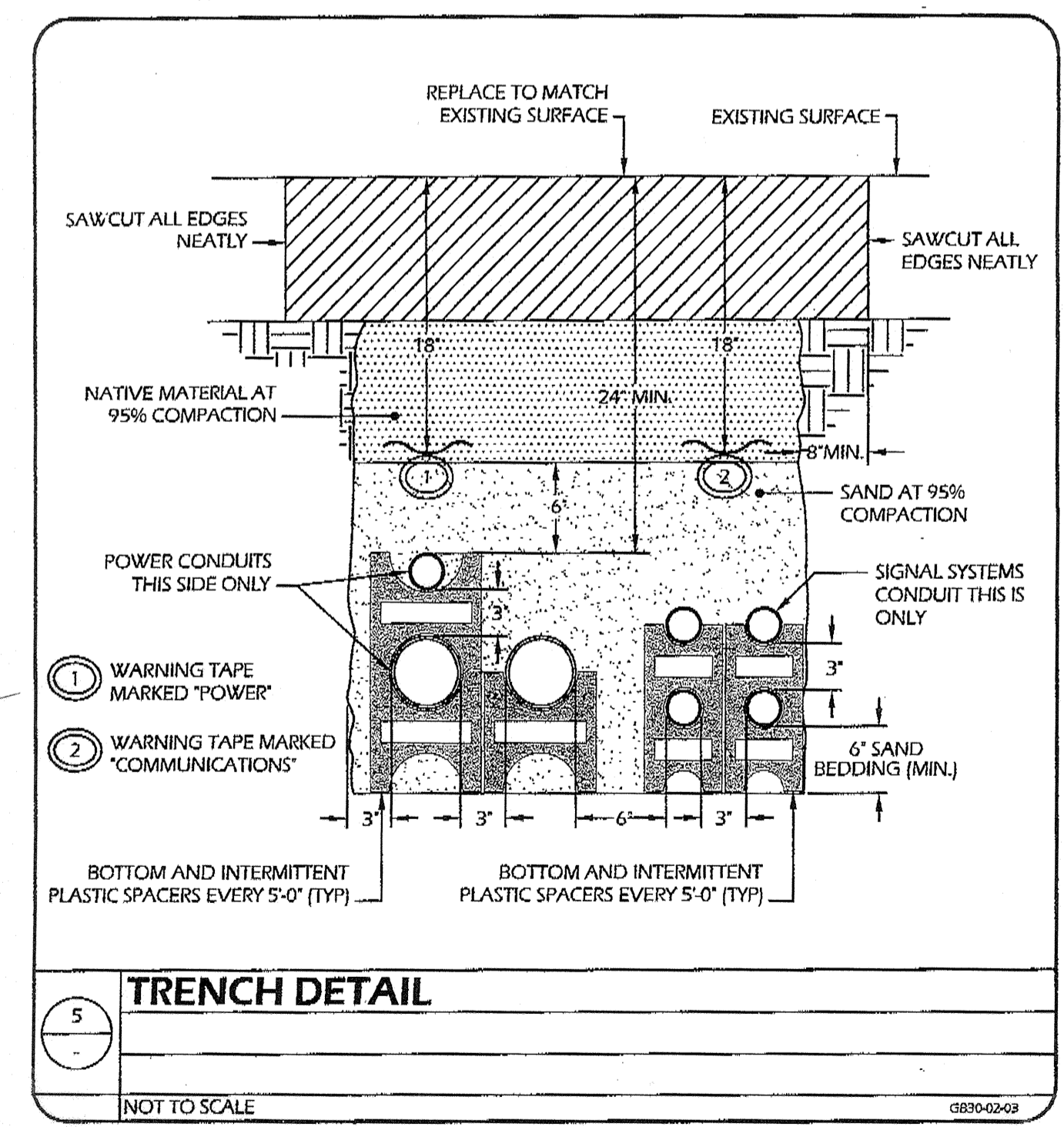
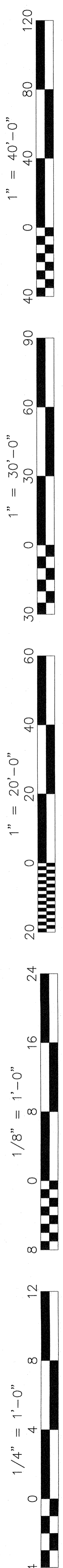

SERVING		120/240V 1Ø 3W		REAR		FLUSH	
NO	NOTE	QTY	AVG	FILE	QTY	FILE	NOTE
1	RECEPTACLE	12/12	20/1	0.7/7.1	60/2	8	10 HVAC 3.5 TON
3	RECEPTACLE	12/12	20/1	0.7/7.1	20/1	12	12 SPACE
5	SPACE	12/12	20/1		20/1	12	12 SPACE
7	SPACE	12/12	20/1		20/1	12	12 SPACE
9	INT/EXT LIGHTS	12/12	20/1	0.8	20/1	12	12 SPACE
11	INT LIGHTS	12/12	20/1	0.8/0.1	20/1	12	12 FIRE ALARM NAC PANEL
		8.7KVA 18.7KVA		72A 72A			

**POWER AND SIGNAL PLAN**  
**3 RELOCATABLE CLASSROOMS**

SCALE : 1/8" = 1' - 0"

**SHEET NOTES**

- APPROXIMATE LOCATION FOR NEW FIRE ALARM DISTRIBUTED POWER MODULE. PROVIDE 110V POWER CONNECTION AND DEDICATED CIRCUIT FROM PANEL A-12. SEE DRAWING E-3 FOR MORE INFORMATION.
- PROVIDE POWER CONNECTION FOR RELOCATABLE BUILDING PRE-WIRED PANEL. SEE SINGLE LINE DIAGRAM ON DRAWING E-4.
- EXISTING 800A PANEL H, PROVIDE NEW CONDUITS AND FEEDERS FOR NEW PRE-WIRED PANEL. POWER CONNECTION. SEE SINGLE LINE DIAGRAM.
- PROVIDE #8 COPPER GROUNDING CONDUCTOR AND BOND TO EACH SECTION STRUCTURAL STEEL BEAM. FIELD VERIFY EXACT LOCATION WITH GENERAL CONTRACTOR PRIOR TO INSTALLATION.
- NEW SECURITY ALARM PANEL AND SYSTEM. PROVIDE 110V POWER CONNECTION AND INTERCONNECTION TO (E) MASTER EQUIPMENT IN ADMIN OFFICE. FIELD VERIFY EXACT LOCATION AND REQUIREMENT WITH OWNER PRIOR TO INSTALLATION. SEE RISER DIAGRAM.
- EXISTING OUTDOOR FEE STAND IDF CABINET. PROVIDE NEW DATA CABLES AND COMPUTER OUTLETS PER PLANS. FIELD VERIFY EXACT LOCATION AND REQUIREMENT WITH OWNER PRIOR TO INSTALLATION. SEE RISER DIAGRAM.
- DATA AND POWER OUTLET AT CEILING FOR SMART BOARD. FIELD VERIFY EXACT LOCATION AND REQUIREMENT WITH OWNER PRIOR TO INSTALLATION. SEE RISER DIAGRAM.
- PROVIDE 50 PAIR PUNCH DOWN BLOCK AND SURFACE MOUNTED BELOW CEILING FOR INTERCOM / TELEPHONE WIRING TERMINATION.
- NEW 24"x24"x4" NEMA3R SIGNAL TO SURFACE MOUNTED ON EXTERIOR WALL. PROVIDE (2) 2" STUB INTO BUILDING ATTIC CAVITY. SEE SIGNAL RISER DIAGRAM.
- SNW OUT AND PATCH EXISTING CONCRETE FLOOR TO INSTALL NEW (2) 2" U.G. CONDUITS FOR SIGNAL AND (1) 3/4" FOR FA. FIELD VERIFY LOCATION WITH OWNER AND GENERAL CONTRACTOR PRIOR TO INSTALLATION. **SEE DETAIL 5/E-2**
- NEW 12"x24" PULL BOX WITH EXTENSION. FIELD VERIFY LOCATION. SEE RISER DIAGRAMS.
- STUB OUT NEW (1) 2" U.G. CONDUITS FOR SIGNAL AND (1) 3/4" FOR FA. FIELD VERIFY LOCATION WITH OWNER AND GENERAL CONTRACTOR PRIOR TO INSTALLATION.
- STUB OUT NEW (1) 1-1/4" U.G. CONDUITS FOR POWER. FIELD VERIFY LOCATION WITH OWNER AND GENERAL CONTRACTOR PRIOR TO INSTALLATION.

**SIGNAL AND COMM. LEGEND**

- SECURITY ALARM SYSTEM**
- DS-C DIGITAL SECURITY ALARM CONTROL PANEL. MODEL SONITROL (64ZONE). INTERFACE WITH EXISTING BUILDING MASTER SECURITY ALARM PANEL AS REQUIRED.
  - K LCO KEYPAD - MATCH EXISTING EQUIPMENT AS REQUIRED.
  - M DUAL TECHNOLOGY CEILING MOUNT DETECTOR. MATCH EXISTING EQUIPMENT AS REQUIRED.
  - B EXTERIOR BELL (SIREN) - DSC/SDIS/VIEW WITH WEATHERPROOF BACKBOX AND TAMPER SWITCH.
  - W DOOR CONTACT SWITCH. RECESS ABOVE DOOR JAMB AT OPEN SIDE.
  - B INDOOR SECURITY ALARM CABLE. WEST PENN #4C224
  - B1 OUTDOOR SECURITY ALARM CABLE. WEST PENN #4CQ224
- COMMUNICATION (TELEPHONE/INTERCOM) SYSTEM**
- ▽ HANSEY/P PHONE - FIELD VERIFY MODEL NO. AND MATCH EXISTING MASTER EQUIPMENT AS REQUIRED.
  - SP CEILING SPEAKER - RAULAND #JUS0221 W/ACC1000 BAFFLE. PROVIDE BACKBOX AND CEILING SUPPORT AS REQUIRED.
  - SP OUTDOOR SPEAKER - ATLAS #AFF15 HORN W/FMR AND LOWELL (#3884 FOR SURFACE, #676X FOR RECESS) BACK BOX W/SILK GRILL
  - T OUTDOOR TELE/AC CABLE. 22AWG SOLID COPPER 12 PAIR SHIELDED AND 12 PAIR UNSHIELDED CABLE.
  - T1 INDOOR TELEPHONE CABLE. CAT.3 22AWG SOLID COPPER 4UTP SHIELDED CABLE.
  - P1 OUTDOOR PA/AC CABLE - WEST PENN #4QC-369
- DATA COMMUNICATION SYSTEM**
- [2] DATA OUTLET - LEVITON CAT 5E (DUAL RECEPTACLE RED IN COLOR FOR ADMINISTRATIVE)
  - [2] DATA OUTLET - LEVITON CAT 5E (DUAL RECEPTACLE BLUE IN COLOR FOR INSTRUCTIONAL)
  - FO FIBER OPTIC CABLE VIA INNER DUCT WITH J-HOOK IN ATTIC AND 2" FOR OUTDOOR. SEE RISER DIAGRAM FOR MODEL NO.
  - C1 (ONE) CAT 5E 22AWG 4UTP. SEE RISER DIAGRAM FOR MODEL NO.
  - C2 (TWO) CAT 5E 22AWG 4UTP. SEE RISER DIAGRAM FOR MODEL NO.

**NOTES:**  
 1. ALL SIGNAL CONDUCTORS CANNOT SPLICE INSIDE PULL BOX. CONDUCTOR MUST BE CONTINUE RUN BETWEEN SIGNAL DEVICES BACK BOX OR ABOVE GROUND TERMINAL CABINET.

Ownership of Documents  
 This document, the ideas and designs incorporated herein, as an instrument of Professional Service is the property of Integrated Designs by SOMAM, Inc. and is not to be used, in whole or in part for any other project without written authorization.  
 © COPYRIGHT 2013

**integrated designs by SOMAM, Inc.**  
 ARCHITECTURE · ENGINEERING · INTERIOR DESIGN · CONSTRUCTION MANAGEMENT  
 6011 N. Fremont, Suite 130, Fresno, California 93710  
 Phone (559) 436-0881 Fax (559) 436-0887 E-Mail: design@somam.com  
 www.integrateddesigns.com

**POWER AND SIGNAL PLAN**

**FREMONT ELEMENTARY SCHOOL**  
**3 RELOCATABLE CLASSROOMS**  
 BAKERSFIELD CITY SCHOOL DISTRICT  
 607 TEXAS STREET, BAKERSFIELD, CA

Issue Date: 00/00/14  
 Date: 05/28/14  
 Designer: J. CHONG  
 DR: J. CHONG  
 PC: C.M

Agency Approval Stamp:  
 FILE # 15-6  
 IDENTIFICATION STAMP  
 DIV. OF THE STATE ARCHITECT  
 OFFICE OF REGULATION SERVICES  
 115890  
 AC: W. FLS. CO. SS. JB  
 DATE: 7/24/14  
 TRACKING #: DSA TRACKING NO.

Stamp(s):

CONSULTING ENGINEERS  
**JOHN S. CHONG ENGINEERING**  
 JOHN S. CHONG  
 E 14419  
 Exp. 6/30/2016  
 ELECTRICAL  
 STATE OF CALIFORNIA

Job No.: **5124**

Sheet No.: **E-2**

Release: 7/8/2014 8:25:10 AM



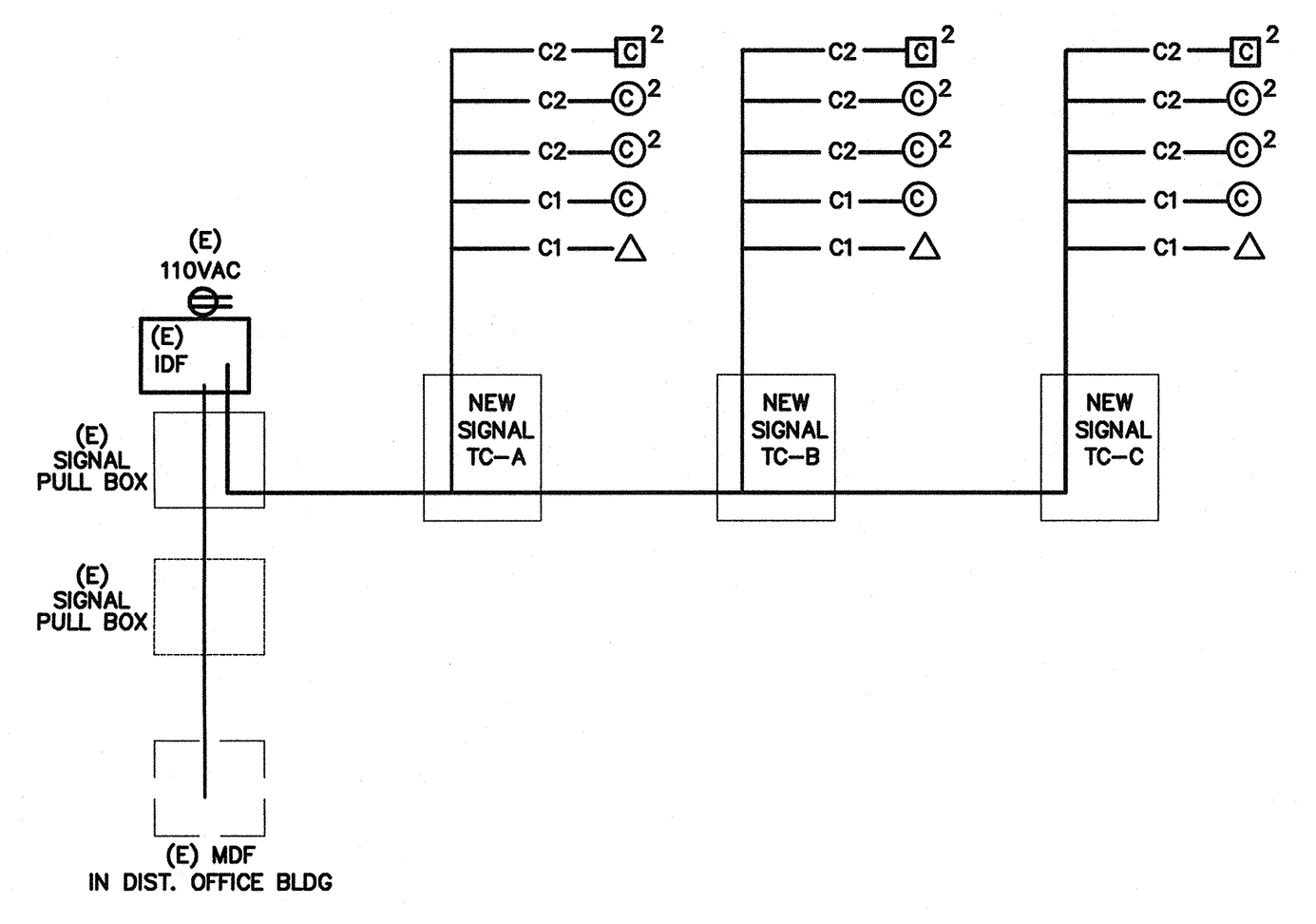
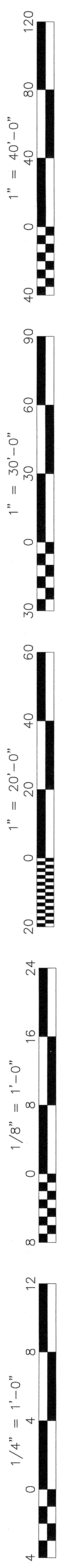

**FIBER OPTIC CABLE**  
THREE MULTIMODE PAIRS (SIX STRANDS) AND THREE SINGLE-MODE PAIRS (SIX STRANDS)  
OPTICAL CABLE COMPANY # DX 12/065D-6W3S8/1UC-6SYMC-YMD/900-OFNR OF EQUAL  
CAT5E\_CABLE  
5ENP4P24-BL-BER-PV OR EQUAL  
CABLE TESTING  
ALL FIBER OPTIC CABLE MUST BE TESTED TO SUPPORT 1000BASE-FX FULL DUPLEX STANDARDS.  
ALL CAT 5E CABLE MUST BE TESTED TO SUPPORT 100BASE-TX.  
TEST RESULTS ARE TO BE PROVIDED TO SCHOOL TECHNOLOGICAL SERVICES FOR REVIEW AND APPROVAL.

**IDF SWITCH EQUIPMENT**  
F/O CISCO WS-C2950C-24 W/ WS-C5484 GBIC  
TP CISCO WS-C2950-24  
CABINETS SOUTH WESTERN DATA PRODUCT SWE 4000-18UBDLK OR EQUAL  
JACKS ALLEN TEL AT55-16 OR EQUAL  
FACEPLATE ALLEN TEL AT50-2-09 OR EQUAL  
PATCH PANEL ALLEN TEL ATPNL-24 OR EQUAL

**LABELING IDENTIFICATION**  
ALL INSTALLED EQUIPMENT, CABLES, TERMINATIONS, ETC. WILL BE PERMANENTLY AND UNIQUELY MARKED. CABLES WILL BE MARKED USING A CONVENTION THAT WILL IDENTIFY ITS ORIGIN AND DESTINATION. LAN TERMINATIONS WILL SIMILARLY BE MARKED TO UNIQUELY IDENTIFY THEM WHILE PROVIDING THE SOURCE AND DESTINATION OF CABLE. IDENTIFICATIONS MUST BE SUCH THAT THEY WILL NOT RUB OFF, FALL OFF, OR EASILY BREAK AWAY.

**DATA COMMUNICATION SYSTEM NOTES**  
1. CONTRACTOR TO PROVIDE ALL EQUIPMENT, PATCH CABLE AND ACCESSORY FOR A FULLY FUNCTIONAL SYSTEM.  
2. NEW DATA JACK WIRING CONFIGURATION MUST BE MATCHED EXISTING SYSTEM. FIELD VERIFY PRIOR TO INSTALLATION.  
3. ADMINISTRATIVE NODE TO BE RED IN COLOR WITH THE INSTRUCTIONAL NODE TO BE BLUE IN COLOR. NODE LOCATION MUST BE 12" WITHIN POWER RECEPTACLE AND FIELD VERIFY EXACT LOCATION WITH OWNER PROJECT COORDINATOR OR TECHNOLOGICAL SERVICES PERSONNEL PRIOR TO INSTALLATION.  
4. ALL EQUIPMENT DOCUMENTATION AND WARRANTY INFORMATION WILL BE PROVIDED TO OWNER TECHNOLOGICAL SERVICES. WARRANTY CARDS WILL BE PROVIDED TO VUSD TECHNOLOGICAL SERVICES FOR FILING WITH MANUFACTURERS UPON COMPLETION OF INSTALLATION.

7 DATA COMMUNICATION SYSTEM RISER DIAGRAM N.T.S

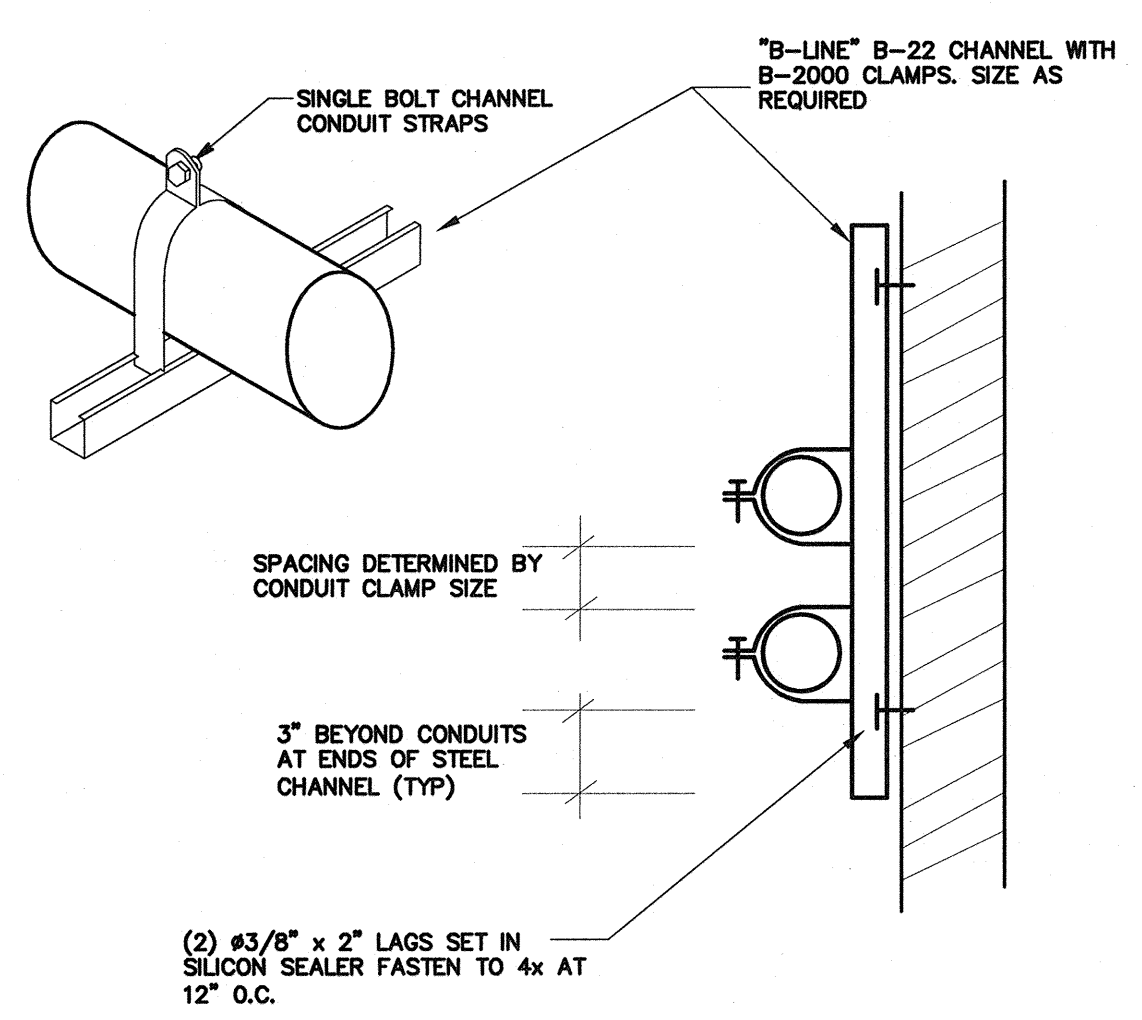

6 CONDUIT SUPPORT DETAIL N.T.S

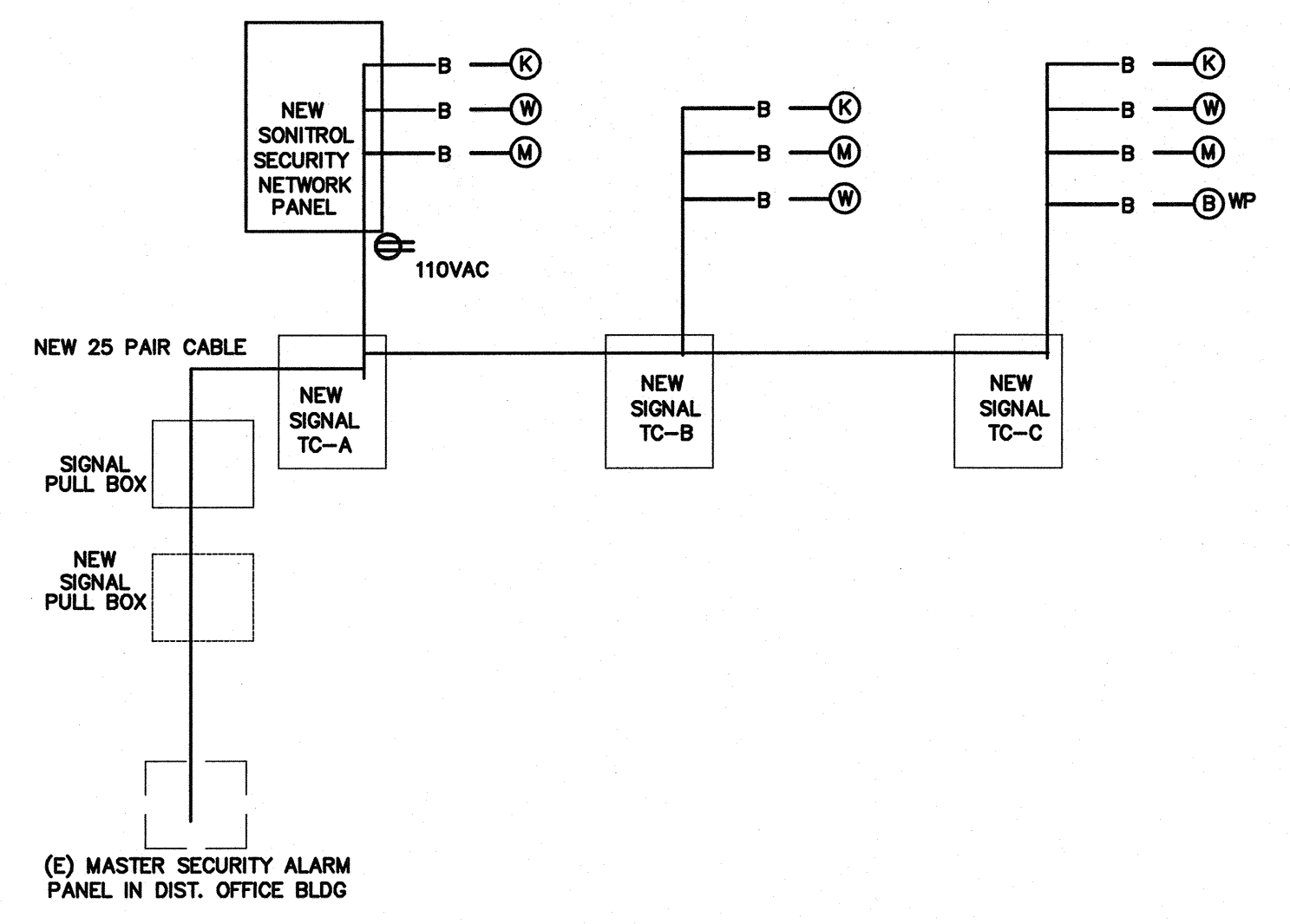

5 SECURITY ALARM SYSTEM RISER DIAGRAM N.T.S

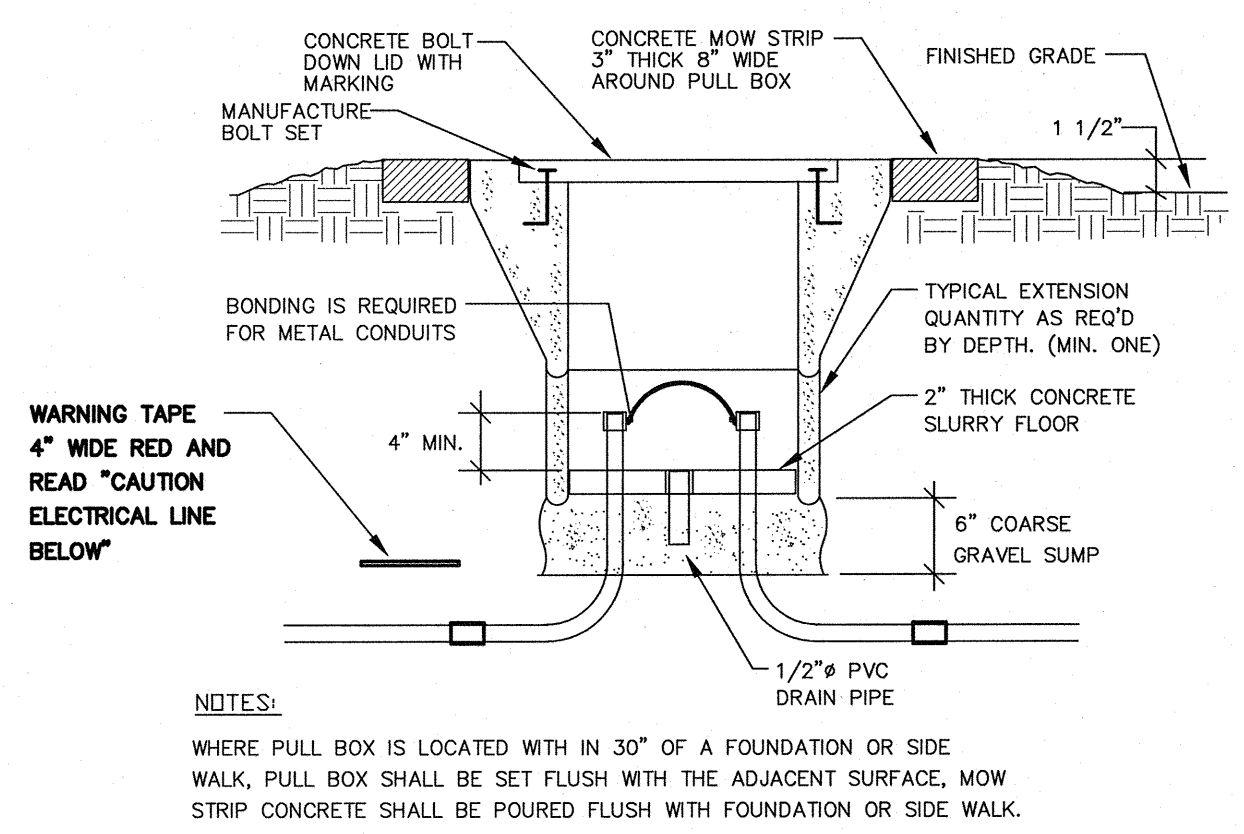

4 PULL BOX AT OPEN YARD DETAIL N.T.S

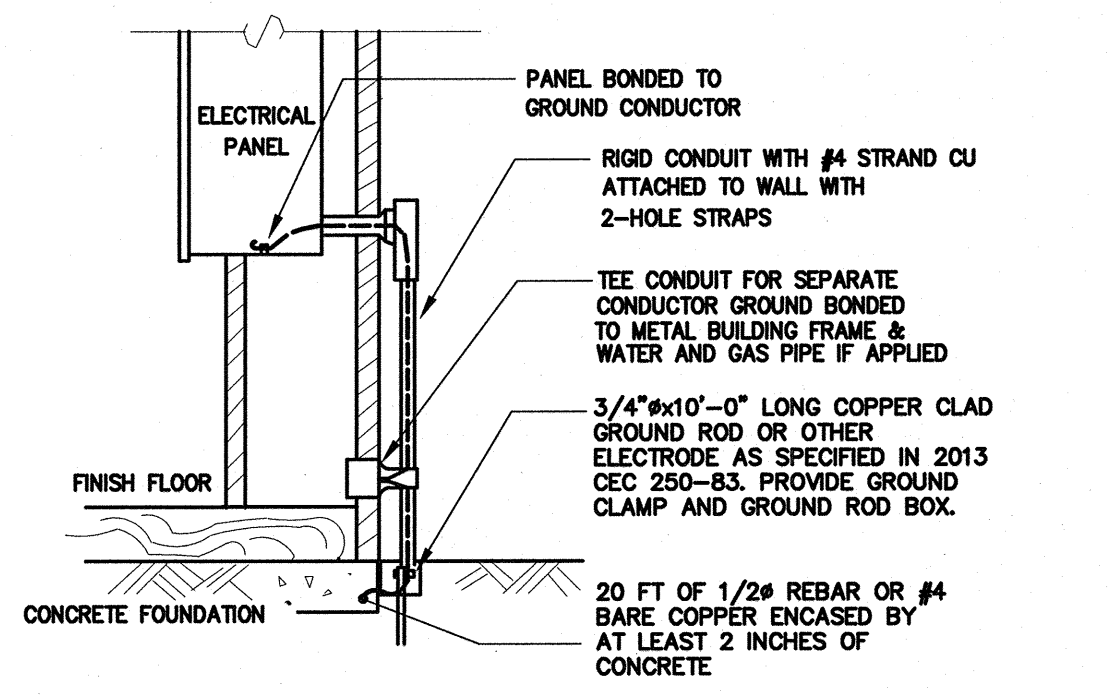

- NOTES:**
1. SIZE OF CONDUCTORS SHALL COMPLY WITH 2013 CEC TABLE 250-66.
  2. BOND SEPARATE CONDUCTORS FROM GROUND ROD TO ELECTRICAL PANEL AND TO METAL BUILDING FRAME PER 2013 CEC 250-50. IN ADDITION TO THE DETAIL SHOWN ABOVE BOND THE ELECTRICAL GROUND TO METAL WATER PIPE EMBEDDED AT LEAST 10 FT. IN SOL. IF AVAILABLE (CEC 250-50, 250-82).
  3. ALL MADE OF METAL FRAME BUILDINGS SHALL BE ELECTRICALLY BONDED TOGETHER, BOND TO HAND RAIL AND WATER PIPE IF APPLIED. (BOLTING ONLY IS NOT ACCEPTABLE BONDING).
  4. CHECK RESISTANCE TO GROUND. IF RESISTANCE EXCEED 25 OHMS, INSTALL ADDITIONAL GROUND RODS WITH CONDUCTORS AS SHOWN SEPARATED AT LEAST 6'-0" UNTIL RESISTANCE IS REDUCED TO 25 OHMS OR LESS (2013 CEC 250-84).
  5. FIELD INSPECTOR SHALL WITNESS GROUNDING TEST.

3 GROUNDING DETAIL N.T.S

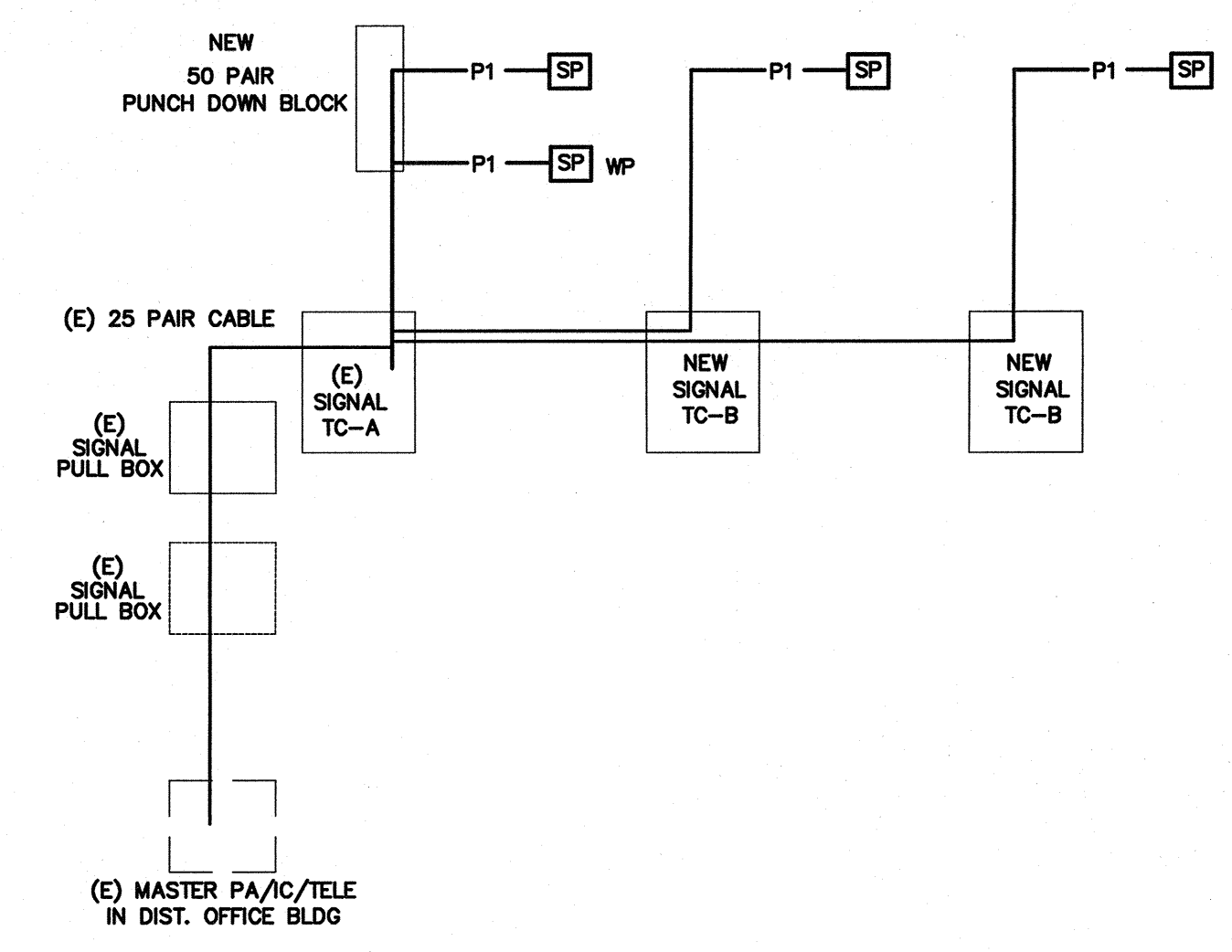

2 PA/IC/TELE SYSTEM RISER DIAGRAM N.T.S

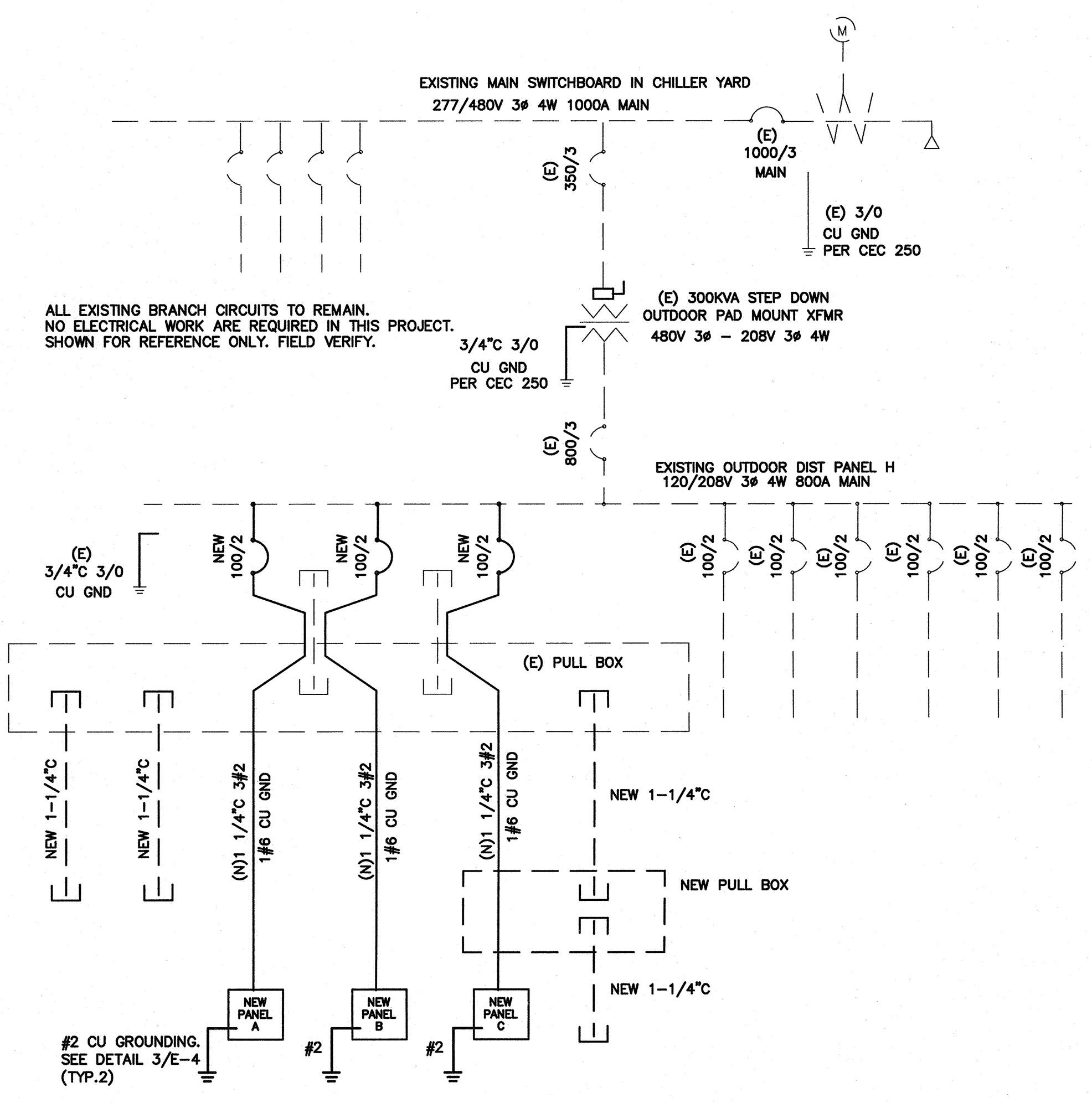

- NOTES:**
1. PROVIDE NEW MATCHING BREAKERS, FEEDERS AND PANELS PER PLANS.
  2. ALL NEW CONDUCTOR SHALL BE 75°C THWN-2 COPPER IN CONDUIT. (AMPACITY FOR CONDUCTOR SELECTION MUST BE DETERMINED/DERATED BY THE ALLOWED TERMINATION RATINGS MARKED/APPROVED ON EACH DEVICES, MOTOR, APPLIANCE, XFMR O.C.P.C. PANEL, ETC. CONDUCTORS INSTALLED IN U.G OR WET LOCATIONS SHALL BE MARKER 'W'. PER 2013 CEC 110-14(C)(1).)
  3. ALL WIRING OVER 100 VOLT SHALL BE INSTALLED IN RACEWAY CONDUIT, EMT ABOVE GRADE, PVC SCH. 40 BELOW GRAD AND STEEL CONDUIT ON EXPOSE SURFACE BELOW 8' AFF. FOR PHYSICAL PROTECTION.
  4. MC CABLE WITH SEPARATE GROUND CONDUCTOR CAN BE USED IN CEILING AND CONCEAL IN WALL.
  5. STEEL BACK BOX SHALL BE PROVIDED FOR ALL NEW ELECTRICAL DEVICES SUCH AS SWITCH, OUTLET AND CONDUCTOR SPLICE.
  6. ELECTRICAL CONTRACTOR IS RESPONSIBLE TO VERIFY THE EXISTING SWITCHBOARD AND PANELS ARE INSTALL PER ONE LINE DIAGRAM PRIOR TO WORKING, AND REPORT TO ENGINEERS IF ANY DISCREPANCY ARE FOUND.

1 SINGLE LINE DIAGRAM N.T.S

CONSULTING ENGINEERS  
**John Chong Engineering**  
2017 E. DELATUR AVE, FRESNO CA 93710  
(559) 915-9266 • FAX 251-2421  
jchenginer@o1.com

REGISTERED PROFESSIONAL ENGINEER  
JOHN S. CHONG  
E 14419  
Exp. 6/30/2016  
ELECTRICAL  
STATE OF CALIFORNIA

Ownership of Documents  
This document, the ideas and designs incorporated herein, as an instrument of Professional Service is the property of Integrated Designs by SOMAM Inc. and is not to be used, in whole or in part for any other project without written authorization.  
© COPYRIGHT 2013

**integrated designs** by SOMAM, Inc.  
ARCHITECTURE - ENGINEERING - INTERIOR DESIGN - CONSTRUCTION MANAGEMENT  
6011 N. Fresno, Suite 100 - Fresno, California 93710  
Phone: (559) 436-0687 Fax: (559) 436-0681 E-Mail: design@somam.com  
www.integrateddesigns.com

Revision	Revision Description	Rev. Date

DETAILS AND SYSTEM DIAGRAMS

Project Name & Address:  
**FREMONT ELEMENTARY SCHOOL  
3 RELOCATABLE CLASSROOMS**  
BAKERSFIELD CITY SCHOOL DISTRICT  
607 TEXAS STREET, BAKERSFIELD, CA

Sheet Title:  
DETAILS AND SYSTEM DIAGRAMS

Issue Date: 00/00/14  
Date: 05/28/14  
Designer: J. CHONG  
DR: J. CHONG  
PC: CJM

Agency Approval Stamp:  
FILE # 15-6  
IDENTIFICATION STAMP  
DIV. OF THE STATE ARCHITECT  
OFFICE OF REGULATION SERVICES  
115890  
AC: JLV FLS CO SS JP  
DATE: 7/24/14  
TRACKING #: DSA TRACKING NO

Stamp(s):

Job No.: **5124**

Sheet No.: **E-4**

Release:

7/8/2014 8:26:20 AM



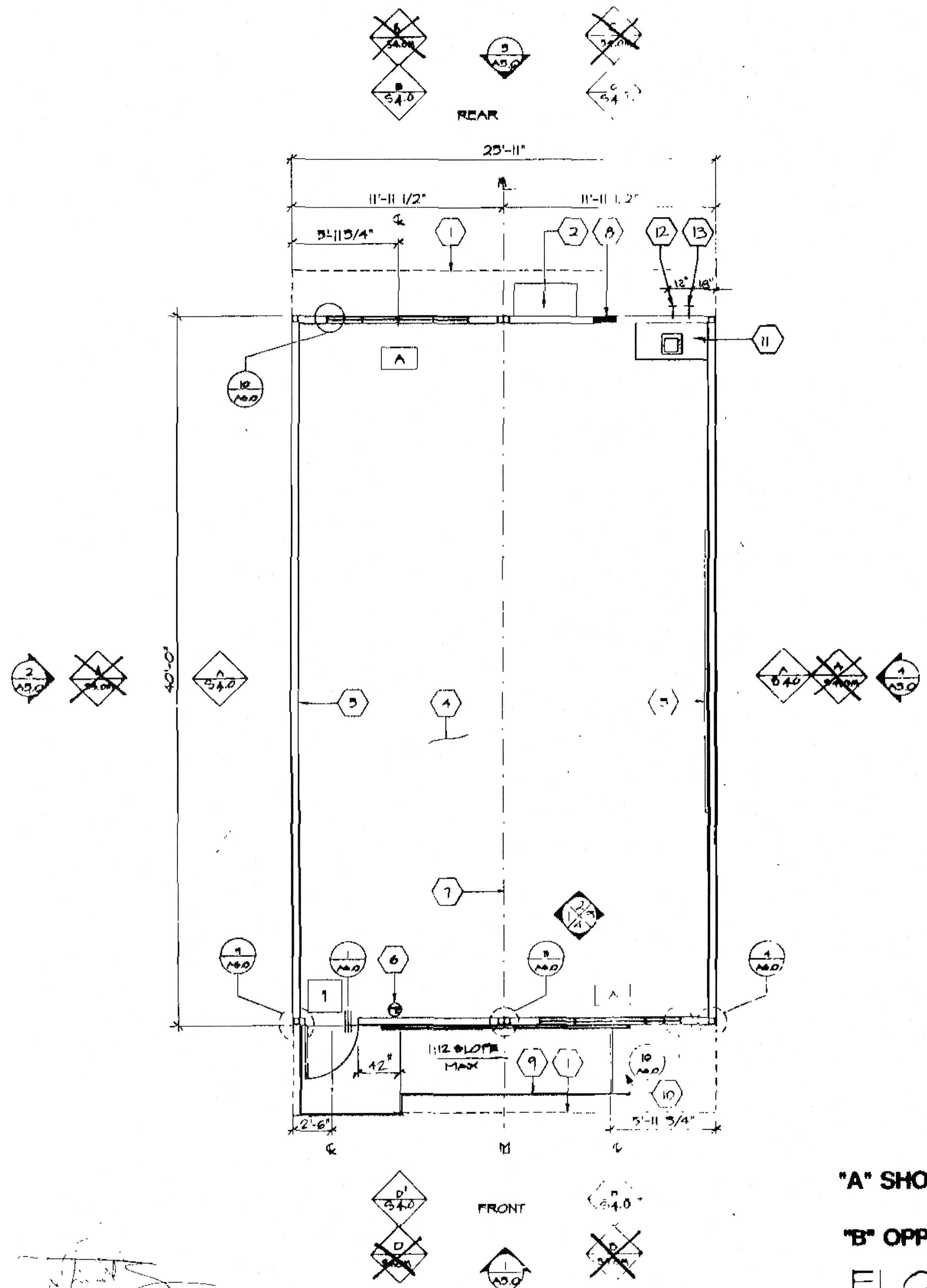

"A" SHOWN  
 "B" OPPOSITE  
 FLOOR PLAN

INTERIOR REFERENCE  
 SHEET A4.0

SCALE 1/4"=1'-0"

**LEGEND**

- 1 EXTERIOR DOOR SEE DOOR SCHEDULE
- A WINDOW (SEE SCHED. A5.0)

**KEY NOTES**

- 1 ROOF OVERHANG
  - 2 HVAC UNIT - SEE M-1.0
  - 3 2- 8'X4' MARKER BOARDS (SEE SPEC'S FOR TYPE)
  - 4 FINISH FLOORING (SEE FINISH SCHED.)
  - 5 TYPICAL INTERIOR FINISH (SEE FINISH SCHED.)
  - 6 FIRE EXTINGUISHER - 5 LBS. DRY CHEMICAL WITH 2A-10BC U.L. RATING ON WALL MTD. RE. HANDLE AT 40"
  - 7 MODLINE (BY TYPICAL)
  - 8 ELECTRICAL PANEL (SEE E1.0)
  - 9 RAMP (SEE R1.0 & R2.0)
  - 10 RAMP LANDING SEE DET. 11 ON SHEET R2.0
  - 11 ACCESSIBLE SINK CABINET. SEE A4.0 SINK: CRA-1725-A GR. 5" DEEP FAUCET: CHICAGO 350. BUBBLER: USB 10
  - 12 COLD WATER PDC.
  - 13 WASTE PDC.
- A. METAL TAG ON ALL MODULES. MECHANICALLY ATTACHED TO REAR EXTERIOR OF BUILDING SHOWING DSA APPLICATION NUMBER, MANUFACTURER'S NAME AND SERIAL NUMBER AND ROOF & FLOOR DESIGN LIVE LOAD.

NOTE:  
 SINK CABINET OPTIONAL

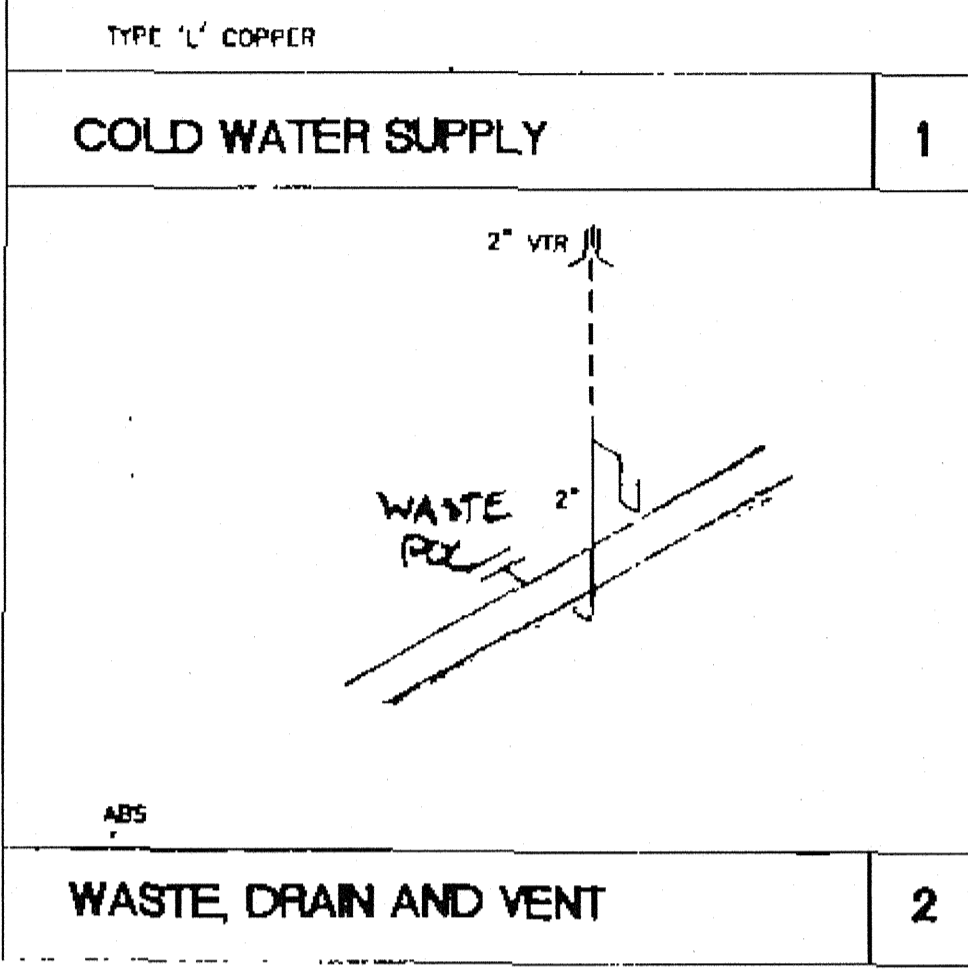

**REVISED**

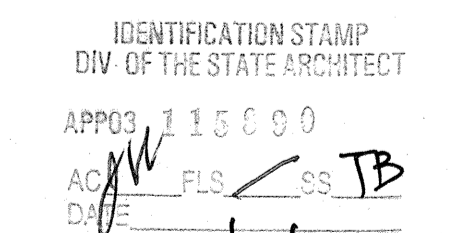
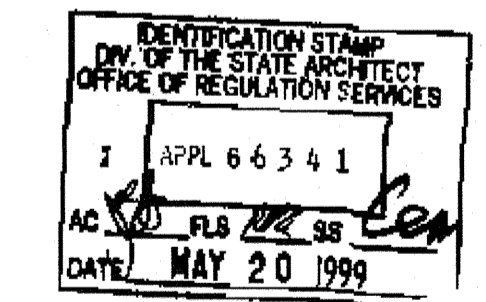

1/32/15 DSA HANDICAP REVISIONS

ARCHITECT	ELECTRICAL	STRUCTURAL	MECHANICAL	FIRE MARSHAL	ACCESS COMPLIANCE	STRUCTURAL SAFETY

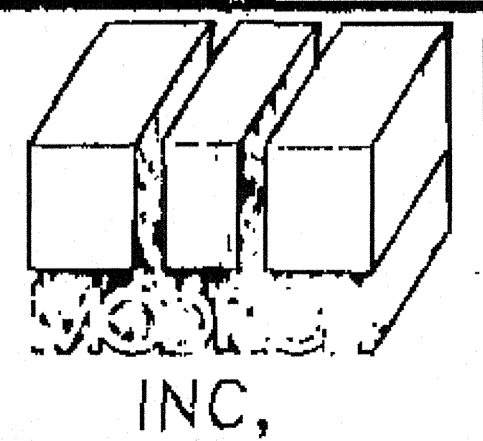

**FLOOR PLAN**

**A1.0A**

**LEGEND**

- 1 EXTERIOR DOOR (SEE DOOR SCHED)
- A EXTERIOR WINDOW (SEE FINISH SCHED)

**KEY NOTES**

- 1 TYPICAL EXTERIOR SIDING (SEE FINISH SCHED)
- 2 EXTERIOR LIGHT FIXTURE (SEE SPECIFICATIONS)
- 3 TOP OF SKIRTING
- 4 RAMP AND LANDING (SEE SHT R-1.0)
- 5 HVAC UNIT (SEE SHT M-1)
- 6 DOWNSPOUT (TYP); FASTEN TO DUG-TYPE 2 PLACES (SEE (Y/A/G-1))
- 7 CONTINUOUS GUTTER WITH DOWNSPOUT (LOCATION OF DOWNSPOUT SHOWN ON ROOF PLAN A2.0)
- 8 SPLASH BLOCK (BY OTHERS)
- 9 FINISH FLOOR LINE
- 10 BOTTOM FLANGE OF FLOOR BEAM
- 11 ROOF HEADER
- 12 VENT (SEE FOUNDATION PLAN)
- 13 FINISH GRADE
- 14 ROOF BEAM (SEE STRUCTURAL)
- 15 COLUMN (SEE STRUCTURAL)
- 16 ELECTRICAL STUD-OUT 1/4" Ø (TYPICAL)
- 17 GROUND STUD-OUT 1/2" Ø (TYPICAL)
- 18 FIRE ALARM HORN NIC.
- 19 NEMA 6"X6" GUTTER DO.
- 20 FIDUCIE

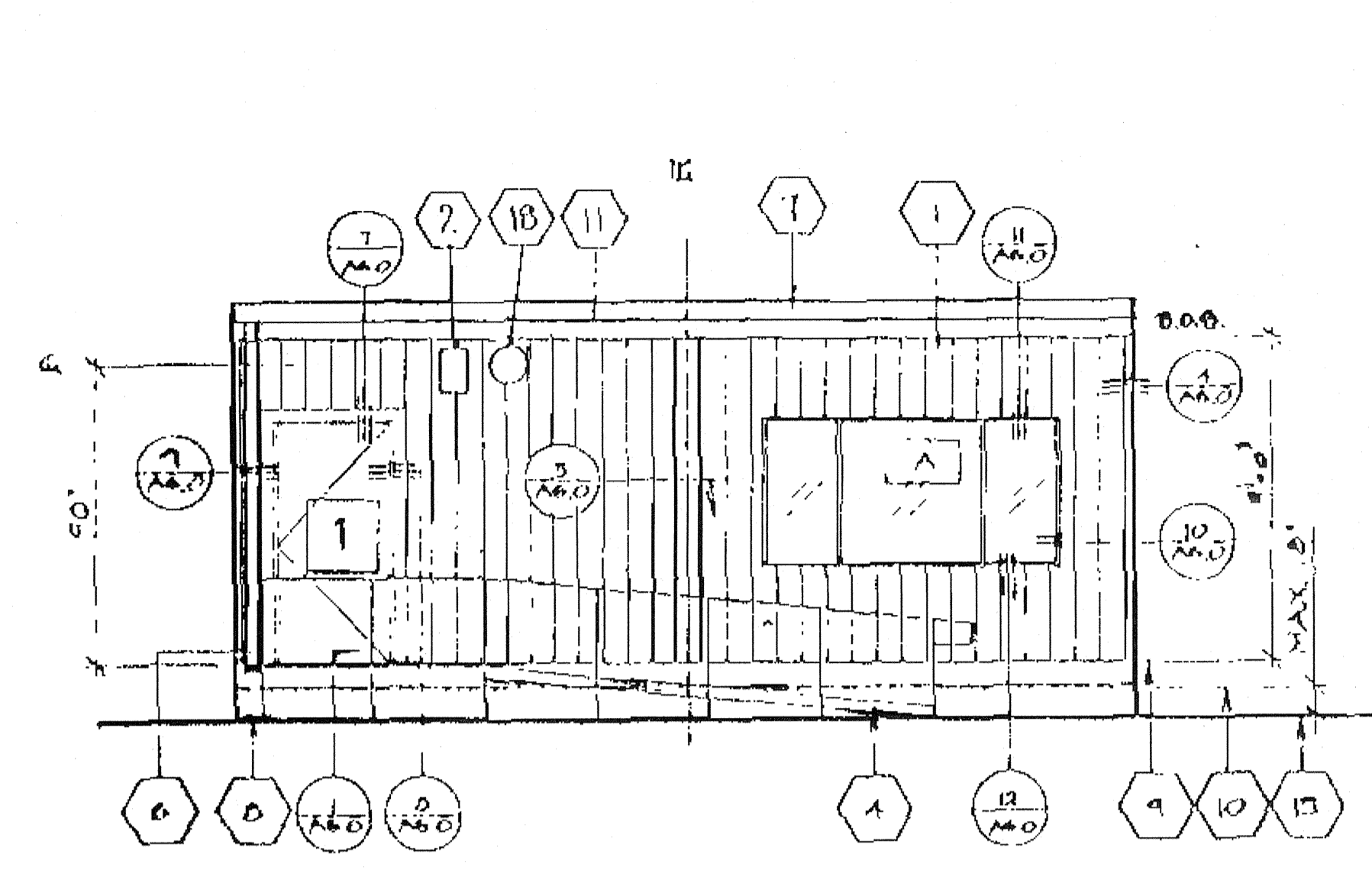

① FRONT ELEVATION

SCALE 1/4"=1'-0"

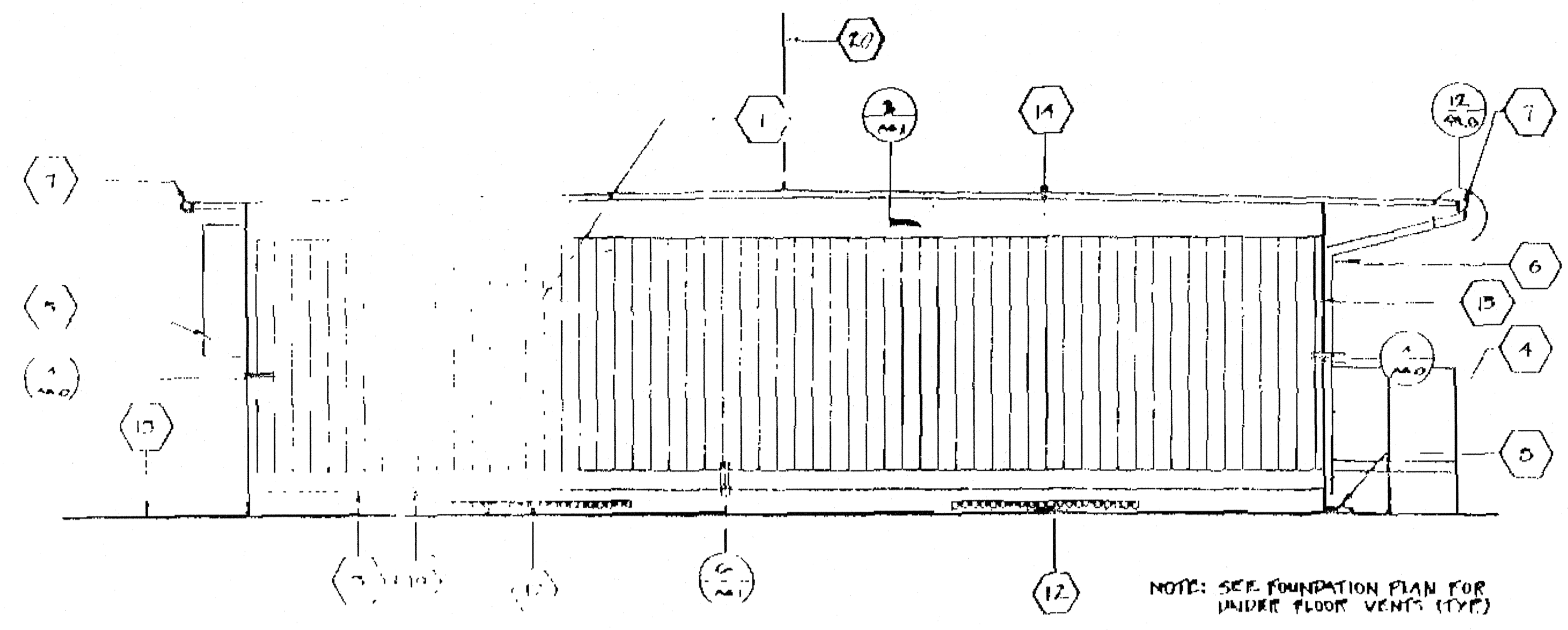

② SIDE ELEVATION

SCALE 1/4"=1'-0"

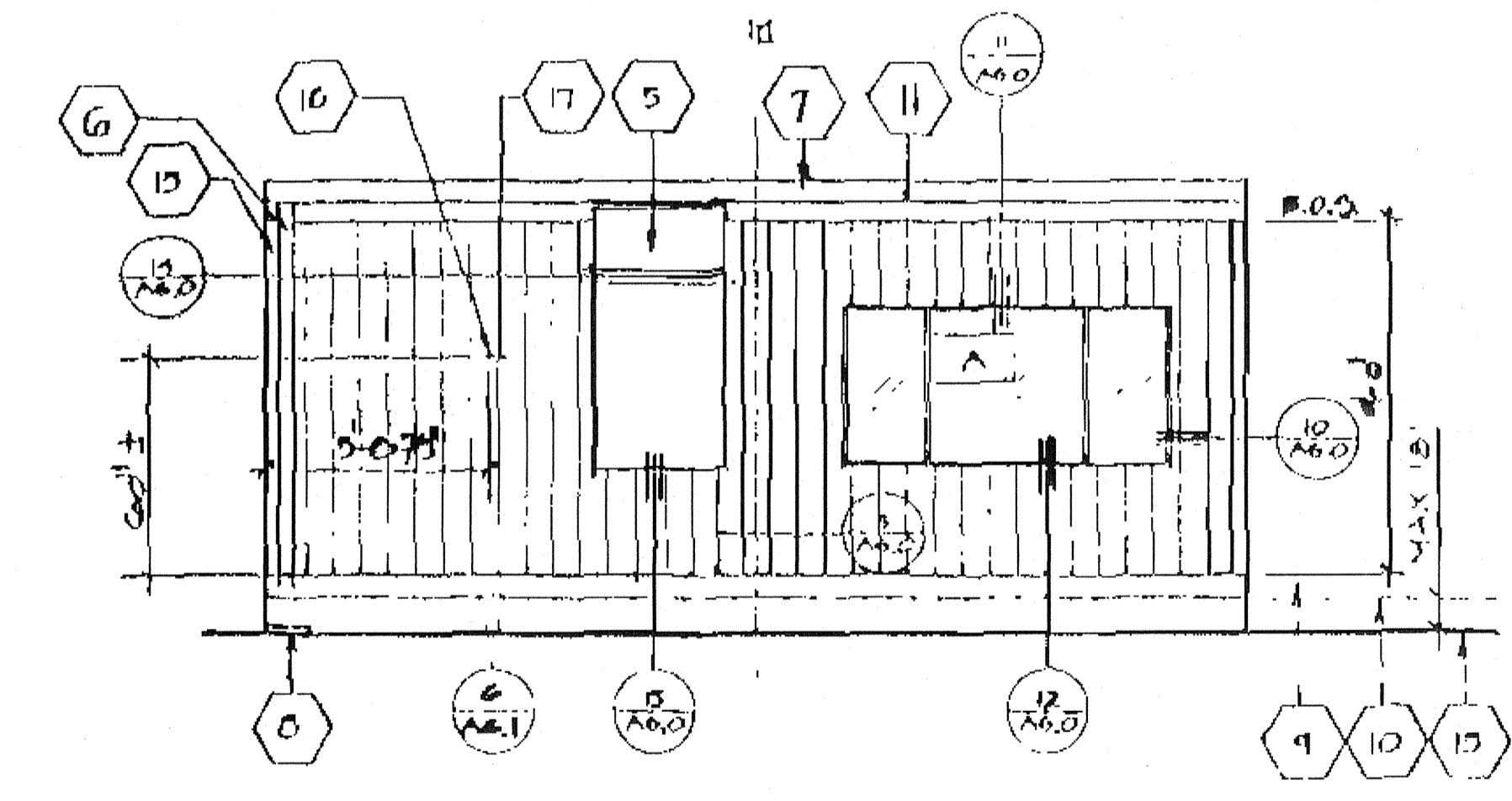

③ REAR ELEVATION

SCALE 1/4"=1'-0"

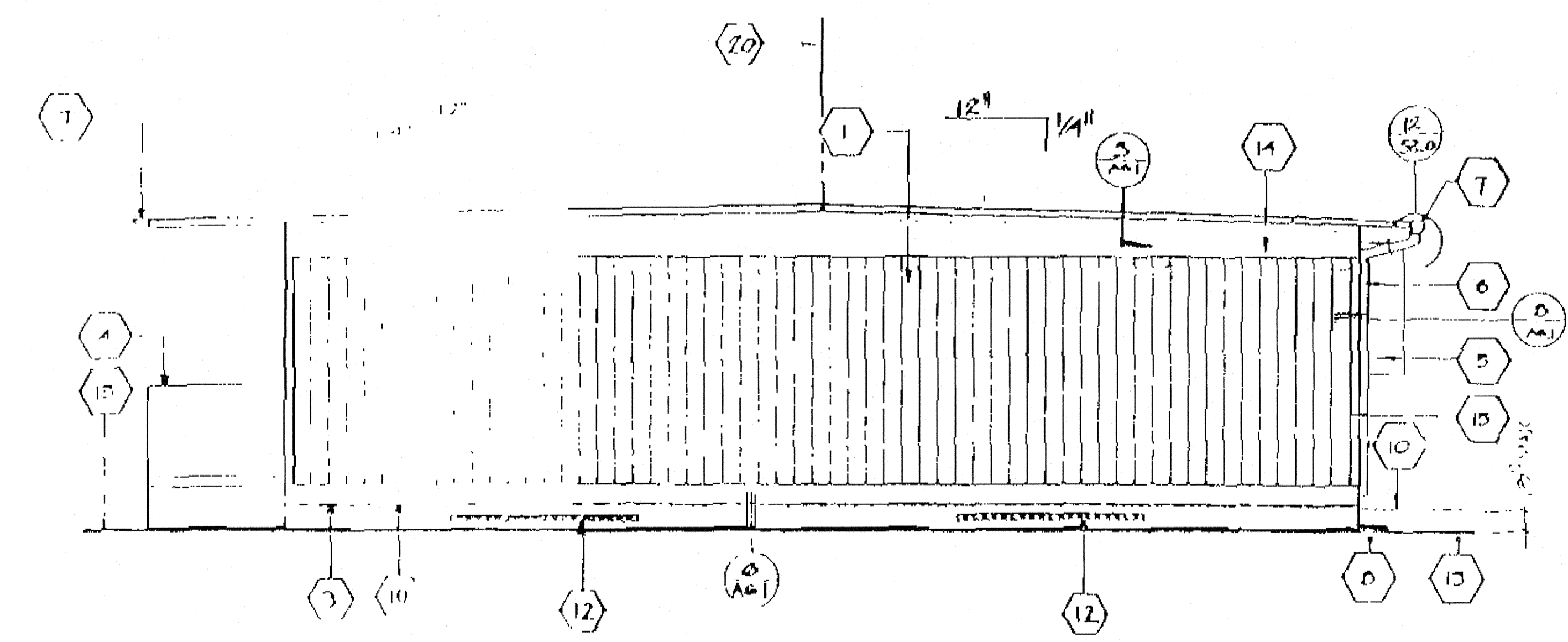

④ SIDE ELEVATION

SCALE 1/4"=1'-0"

"A" SHOWN  
"B" OPPOSITE

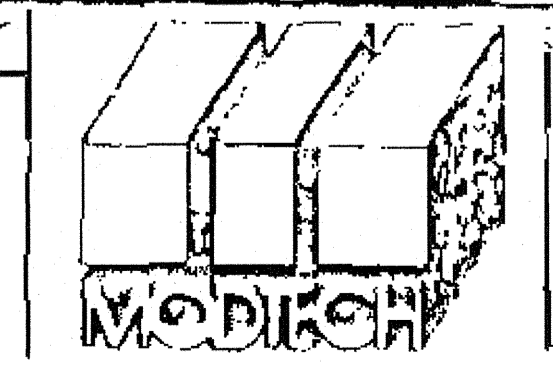
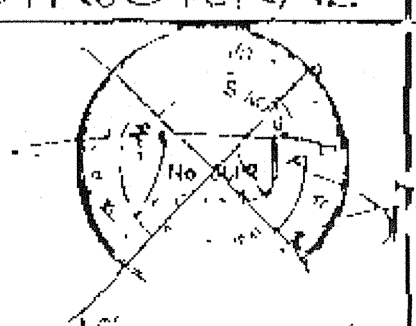
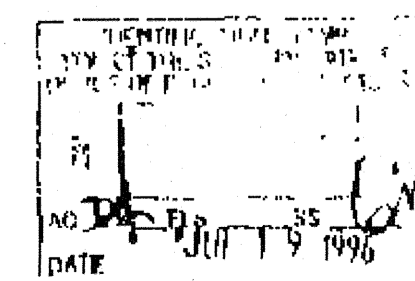
ARCHITECT	ELECTRICAL	STRUCTURAL	MECHANICAL	FIRE MARSHAL	ACCESS COMPLIANCE	STRUCTURAL SAFETY	
							<p>IDENTIFICATION STAMP CIVIL ENGINEER APPROX 110000 AC 11/15/96 DATE 11/15/96</p> <p>SCALE: 1/4"=1'-0"</p> <p>24'X40' DUAL PITCH A3-0A</p>



"MACHINE APPLIED 16d FASTENERS SHALL HAVE AN EMBEDMENT OF NOT LESS THAN 1/2" INTO SECOND MEMBER, AND SHALL BE NOT LESS THAN 3" IN OVERALL LENGTH"

THE ABOVE NAILS SHALL ALSO BE ACCEPTABLE FOR HAND NAILING, PROVIDED THE REQUIRED EMBEDMENT IS MAINTAINED

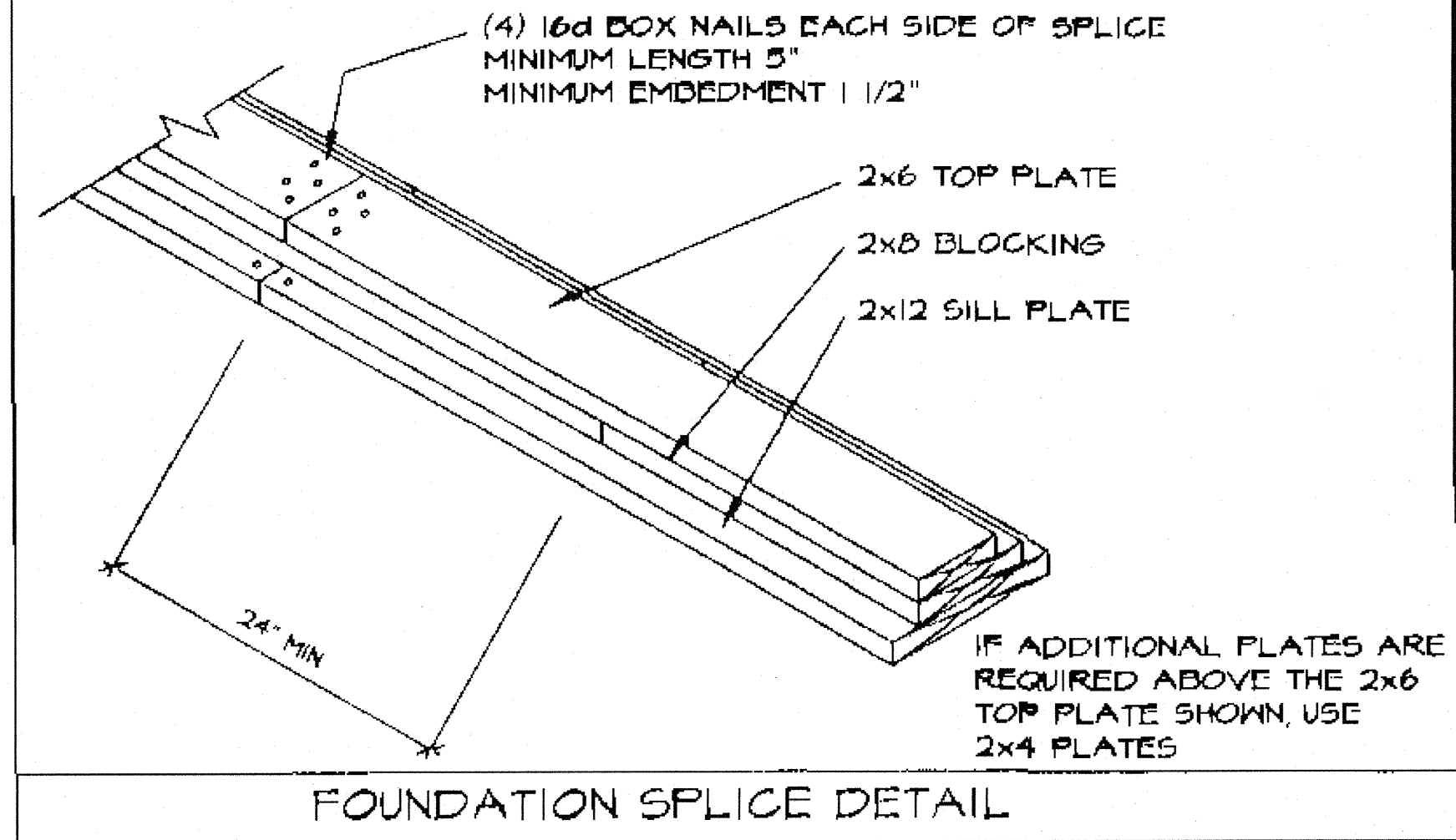

**KEY NOTES**

- 1 2"x6" SILL PLATE (END WALL)
- 2 6- 2X12X30" LONG SILL PADS
- 3 PIPE TO GRADE (TYP.)
- 4 3" HIGH BY 6'-6" LONG VENT
- 5 2X12 SILL PLATE (SIDE WALL)
- 6 4-2X12X30" LONG SILL PADS
- 7 6"x12"x10 GA. PLATES
- 8 1" Ø PIPE EA. END EA. PAD AT ADJ. BLDG. LINE
- 9 5/8" Ø X4" LAG (4-PER BLDG. MIN.)
- 10 6- 2X12X30" LONG SILL PADS

**GENERAL NOTES:**

- A. SOIL RESTRAINT: ON A.C. PAVING AND ON SOIL 1" O.D. GALVANIZED PIPE AT 10'-0" 12" PENETRATION BELOW SURFACE VERTICALLY. DRILL SILL 1-1/4" MAX. PIPE MAY BE DRIVEN MAX. OF 45° ANGLE TO VERTICAL. (10-1/2" LONG PIPE REQUIRED FOR PENETRATION AT 45° ANGLE)
- B. ON CONCRETE PAVING HILTI DS 82-PI0 THRU SILL PLATE:  
END WALLS: 8" O.C.  
SIDE WALLS: 22" O.C.
- C. WHERE SHIM STOCK IS REQUIRED FOR LEVELING USE 1/4", 1/2", OR 3/4" THICK PLYWOOD SAME WIDTH AS BLOCK. P.T.
- D. VERIFY DRAINAGE TO PREVENT WATER FROM PONDING BENEATH THE STRUCTURE WITH DISTRICT ARCHITECT SITE PLANS
- E. ALL FOUNDATION MATERIAL SHALL BE HEM FIR  
GROUND CONTACT: LP-22 (CCA 40)  
ABOVE GROUND: LP-2 (CCA 25)
- F. FOUNDATION DESIGNED FOR 1000 PSF SOIL BEARING PRESSURE PER ORS IR 25-6.  
ABOVE GROUND: LP-2

5" X 24" END WALL VENTS AS REQUIRED FOR ADJACENT BUILDING APPLICATIONS MIN. 10" FROM BLDG. CORNERS MIN. 10" FROM MODLINES MIN. 12" BLOCKING BETWEEN VENTS

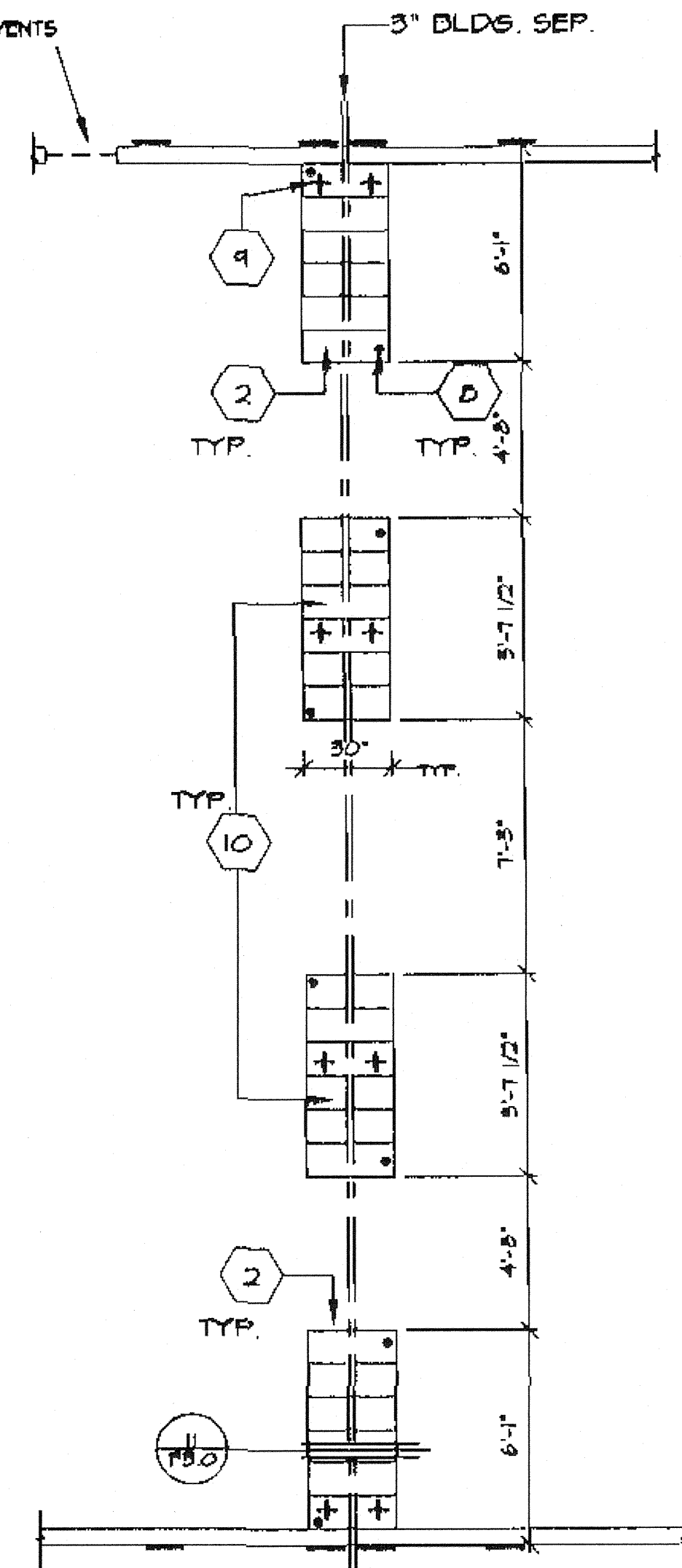

PAD FTG'S AT ADJ. BLDG.

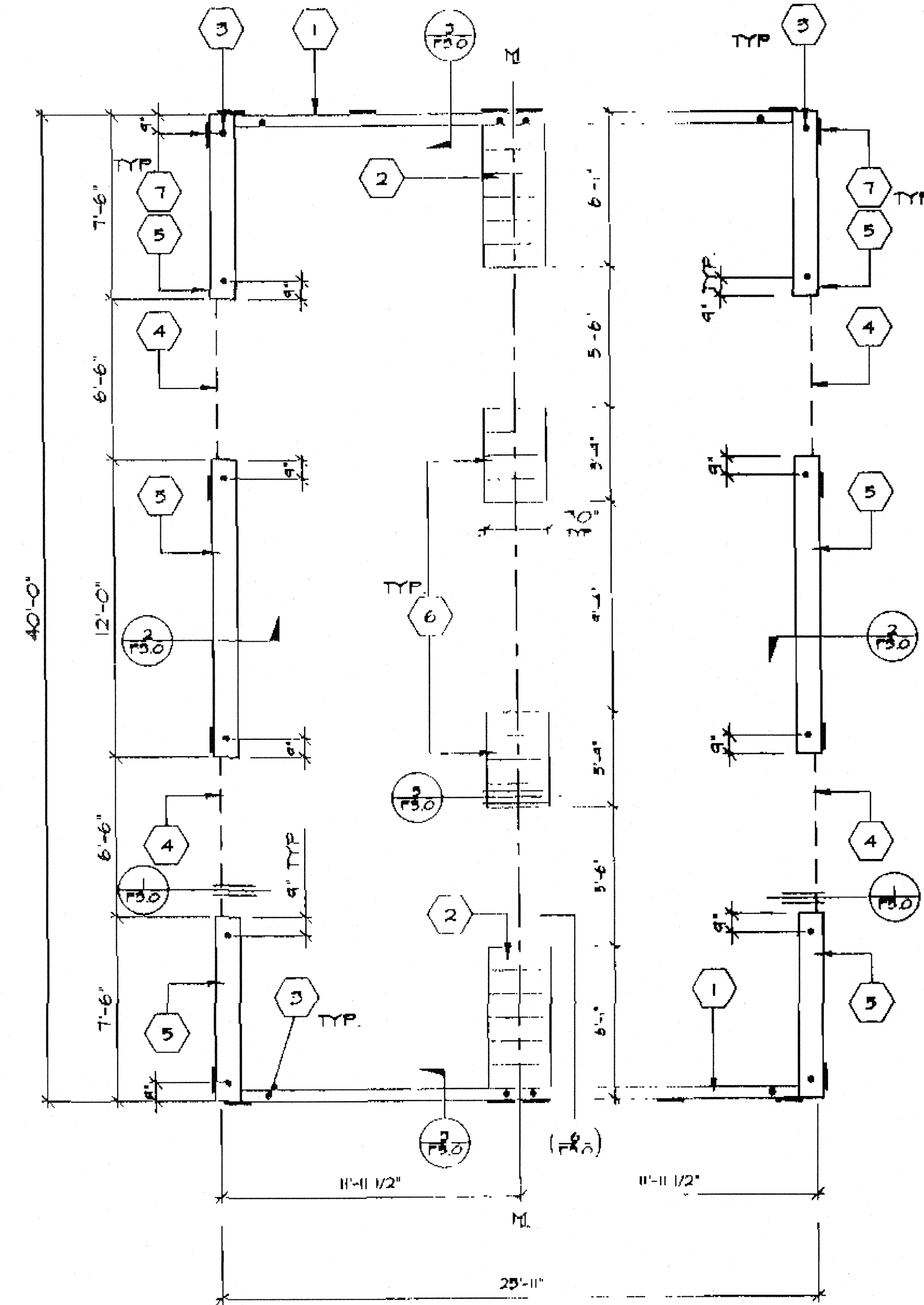

**VENT CALCS.**  
 BLD'G SIZE 24' X 40' = 960 sq  
 VENTILATION REQ'D 960 ÷ 150 = 6.4 sq  
 3' X 6'-6" VENT = 1.625 sq  
 4 VENTS X 1.625 sq = 6.5 sq  
 6.5 sq > 6.4 sq

**FOUNDATION (WOOD SILL)**

24 x 40 - 50 PSF LL

SCALE 1/4"=1'-0"

REVISIONS

ELECTRICAL	MECHANICAL	STRUCTURAL	ARCHITECT	DIVISION OF THE STATE ARCHITECT
				<p>REVISED MAR 27 1996</p> <p>IDENTIFICATION STAMP            DIV. OF THE STATE ARCHITECT            OFFICE OF REGULATION SERVICES</p> <p>PC 275</p> <p>DATE 7/14/96</p>

**MODTECH INC.**  
 2830 BARRETT AVE.  
 PERRIS, CA. 92572  
 PH. (909) 943-4014  
 FX. (909) 940-0427

CONFIDENTIAL - THIS DOCUMENT AND THE INFORMATION CONTAINED HEREIN ARE THE PROPERTY OF MODTECH INC. UNAUTHORIZED COPYING, DISCLOSURE, OR OTHER UNAUTHORIZED USES ARE PROHIBITED

JOB NO. \_\_\_\_\_

IDENTIFICATION STAMP  
 DIV. OF THE STATE ARCHITECT

APPROX. 115000

AC. \_\_\_\_\_

DATE - DEC 11, 1996

7/24/96

**FOUNDATION PLAN**

DRAWN BY  
 DATE  
 CHECKED BY  
 DATE

**FO.**

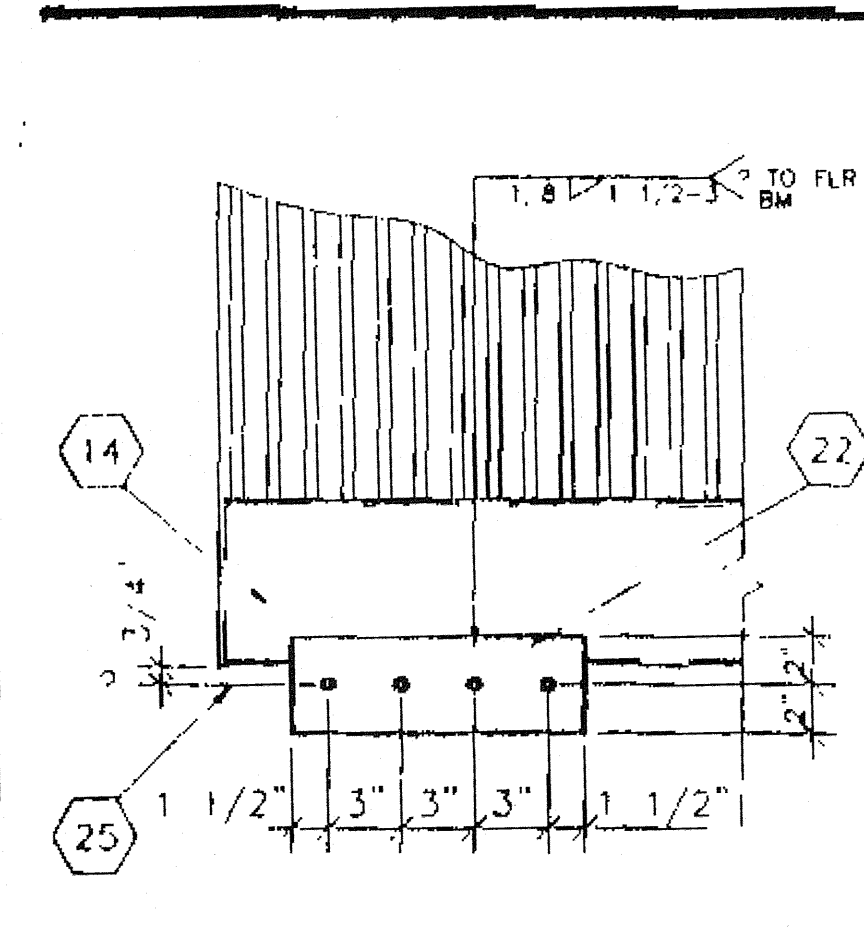

9 SCALE: 1 1/2"=1'-0"  
ALTERNATE HOLD DOWN

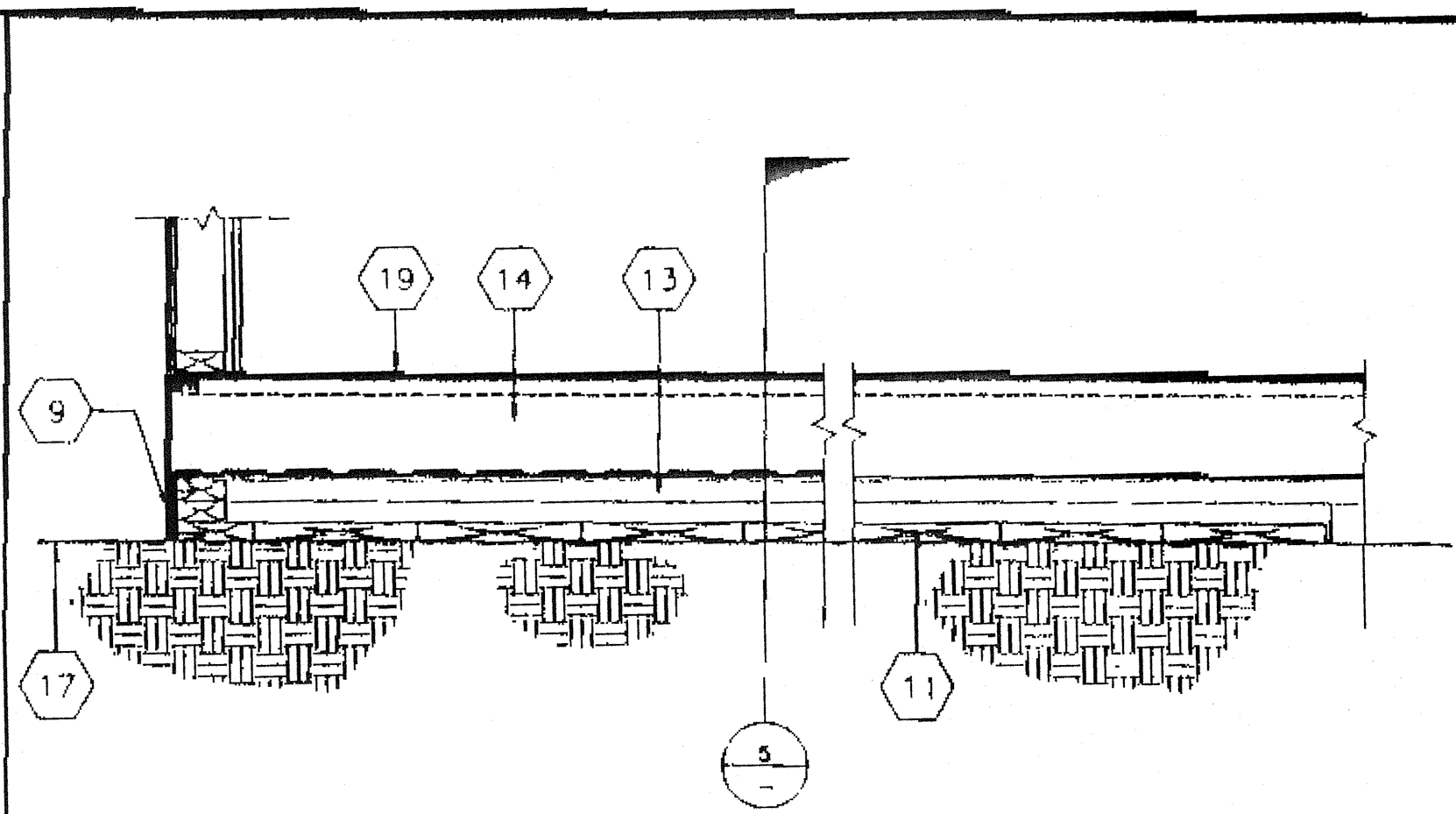

6 SCALE: 1 1/2"=1'-0"  
MODLINE PAD @ END WALL

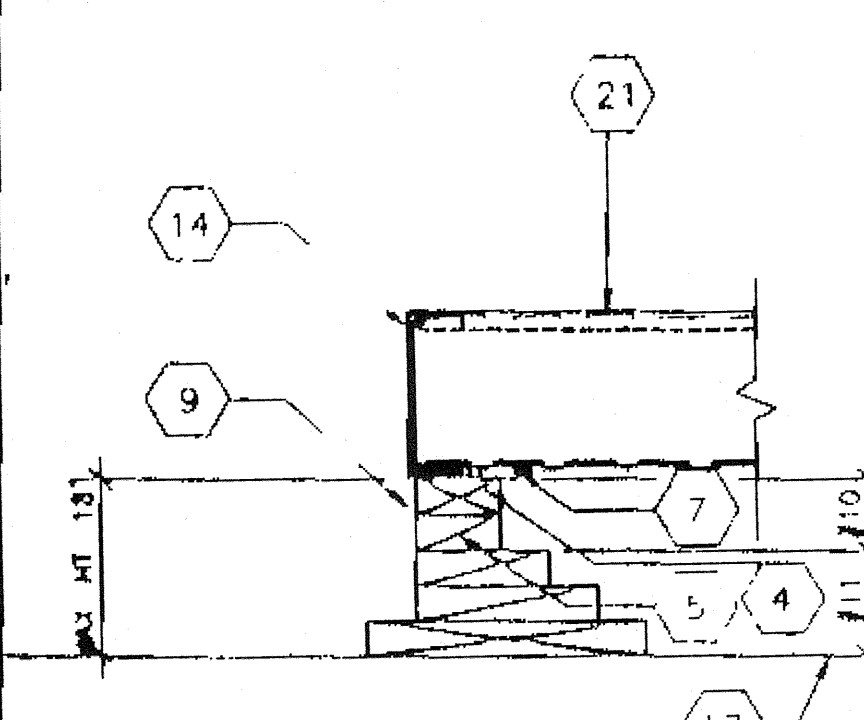

10 SCALE: 1 1/2"=1'-0"  
ADD BLK'S/SHIMS TO LEVEL FOUND.

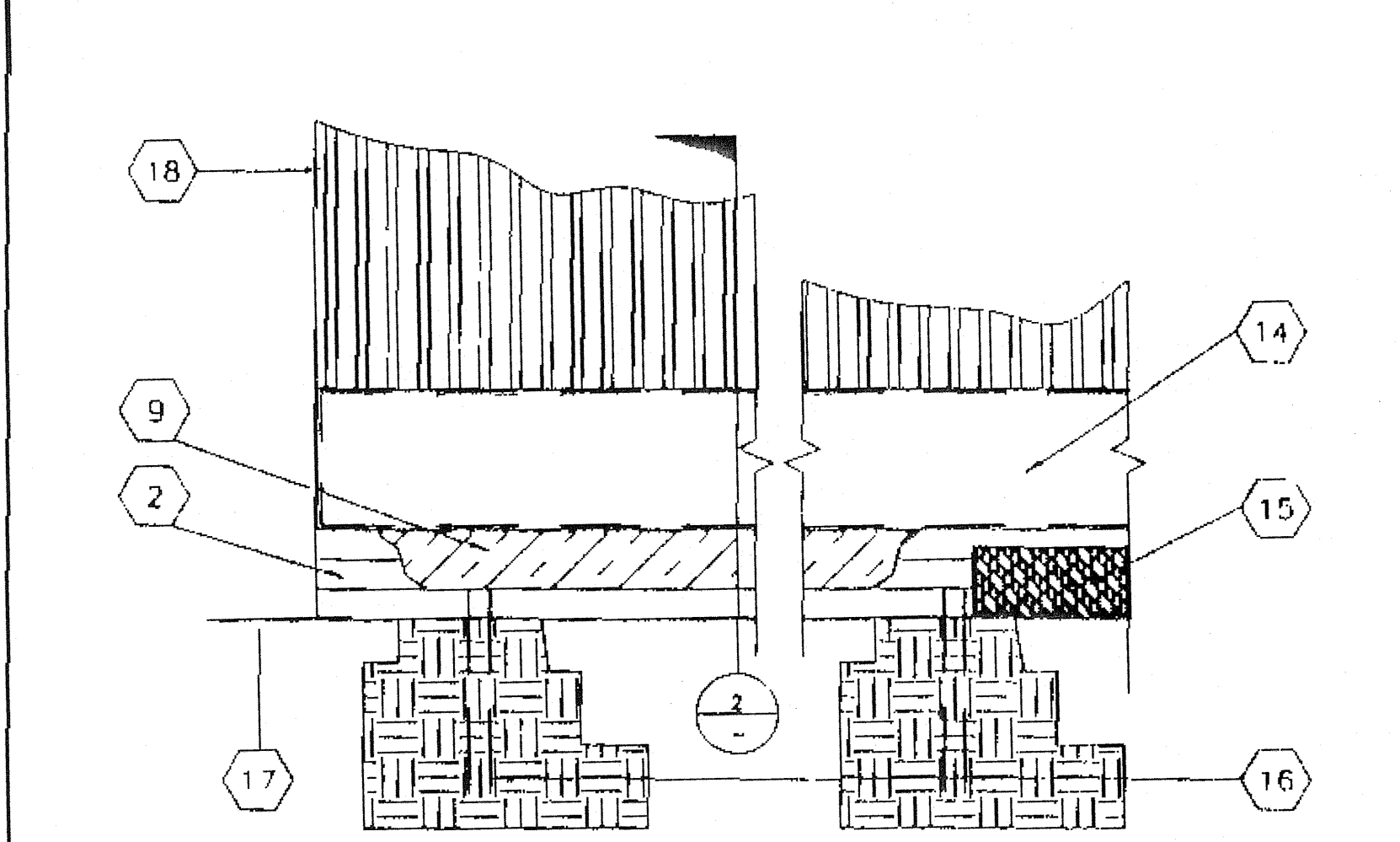

7 SCALE: 1 1/2"=1'-0"  
FOUNDATION ELEVATION @ SIDE WALL

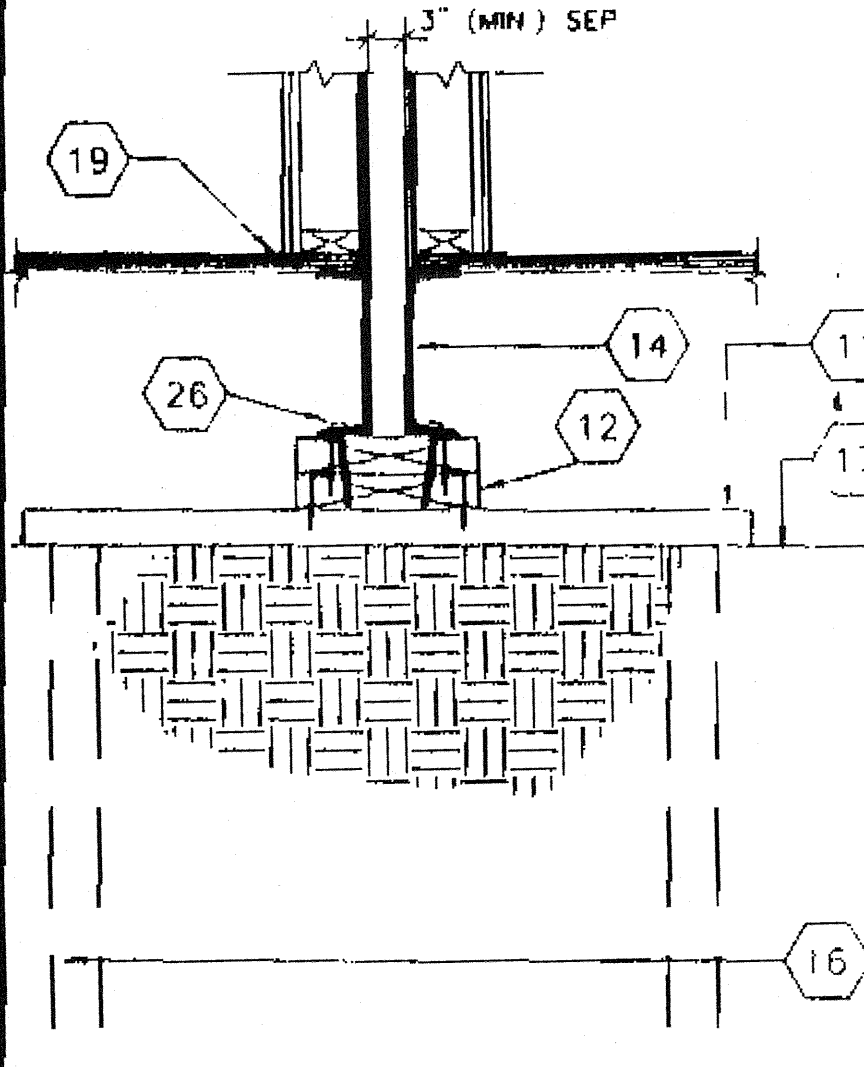

11 SCALE: 1 1/2"=1'-0"  
FOUND. AT ADJ. BLDG

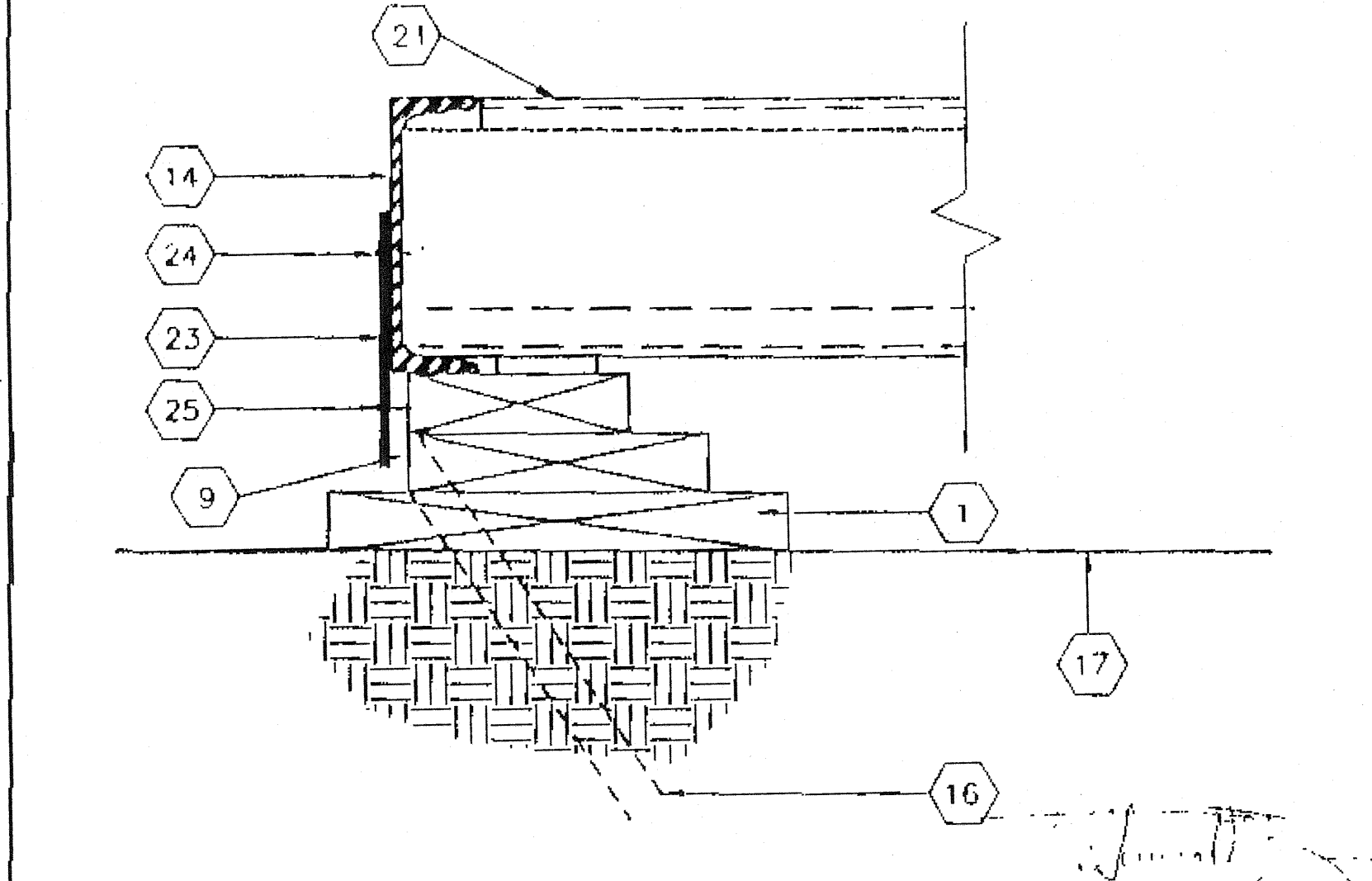

8 SCALE: 3"=1'-0"  
TYPICAL TIE PLATE

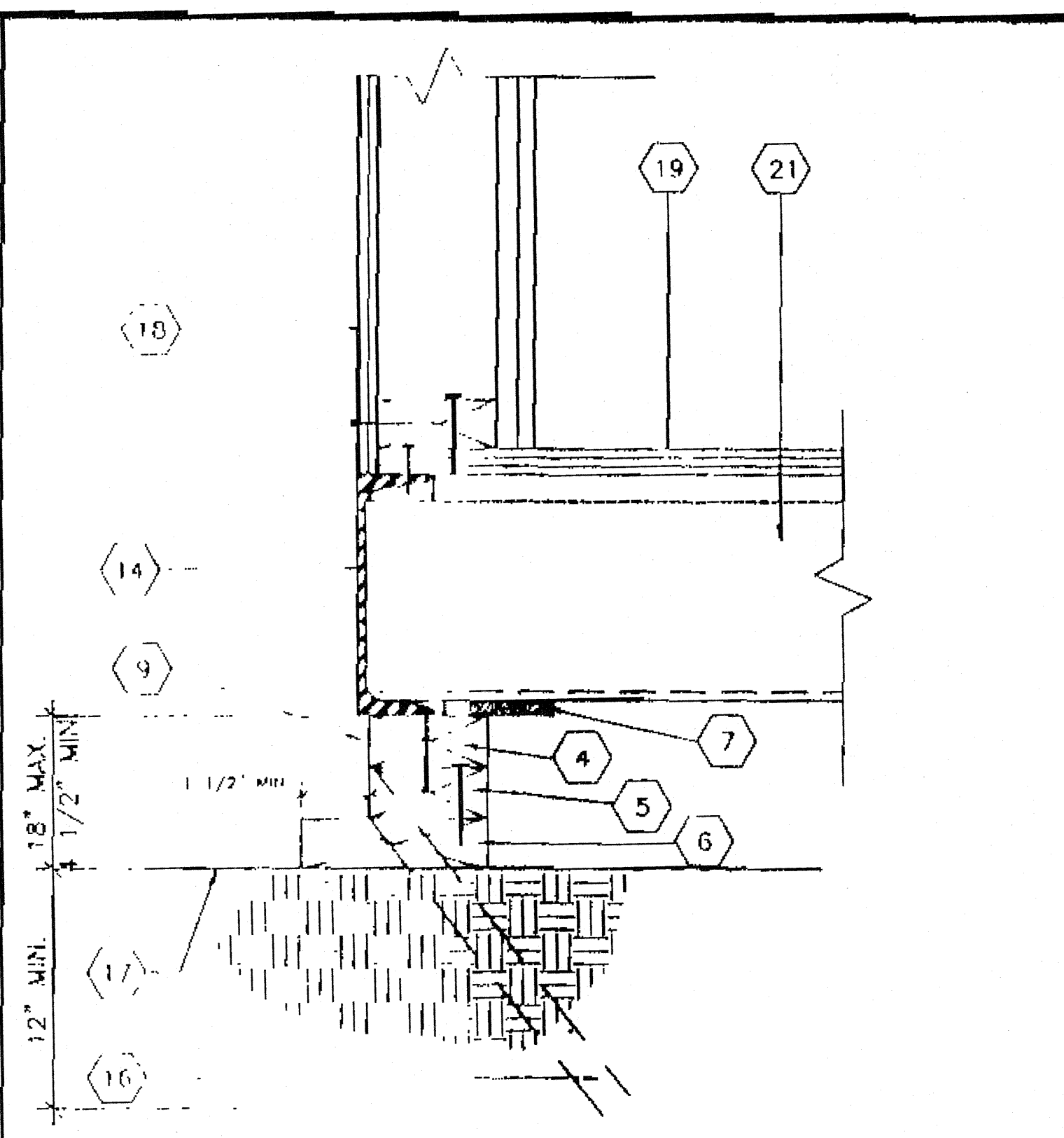

3 SCALE: 3"=1'-0"  
FOUNDATION @ END WALL

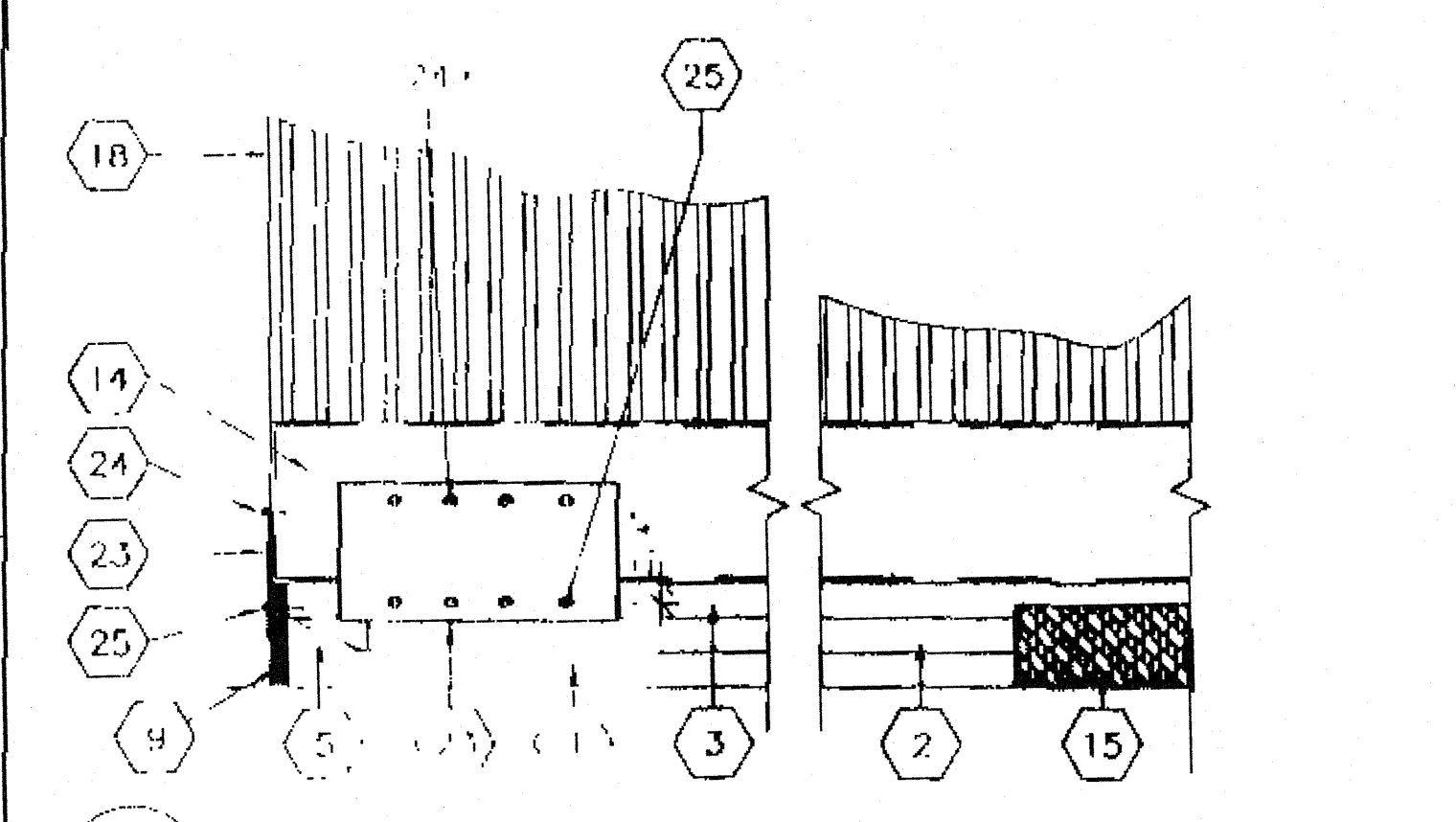

4 SCALE: 1 1/2"=1'-0"  
DETAIL @ FOUNDATION CORNER

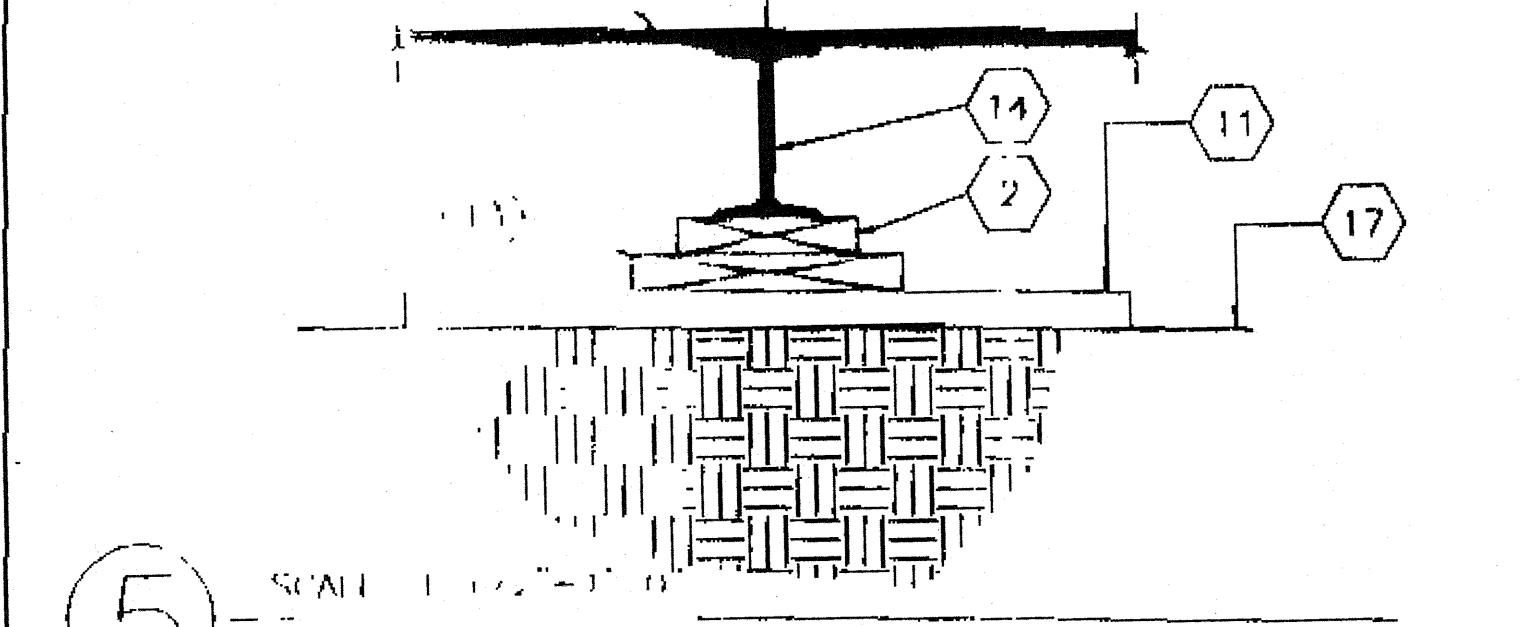

5 SCALE: 1 1/2"=1'-0"  
FOUNDATION PAD @ MODLINE

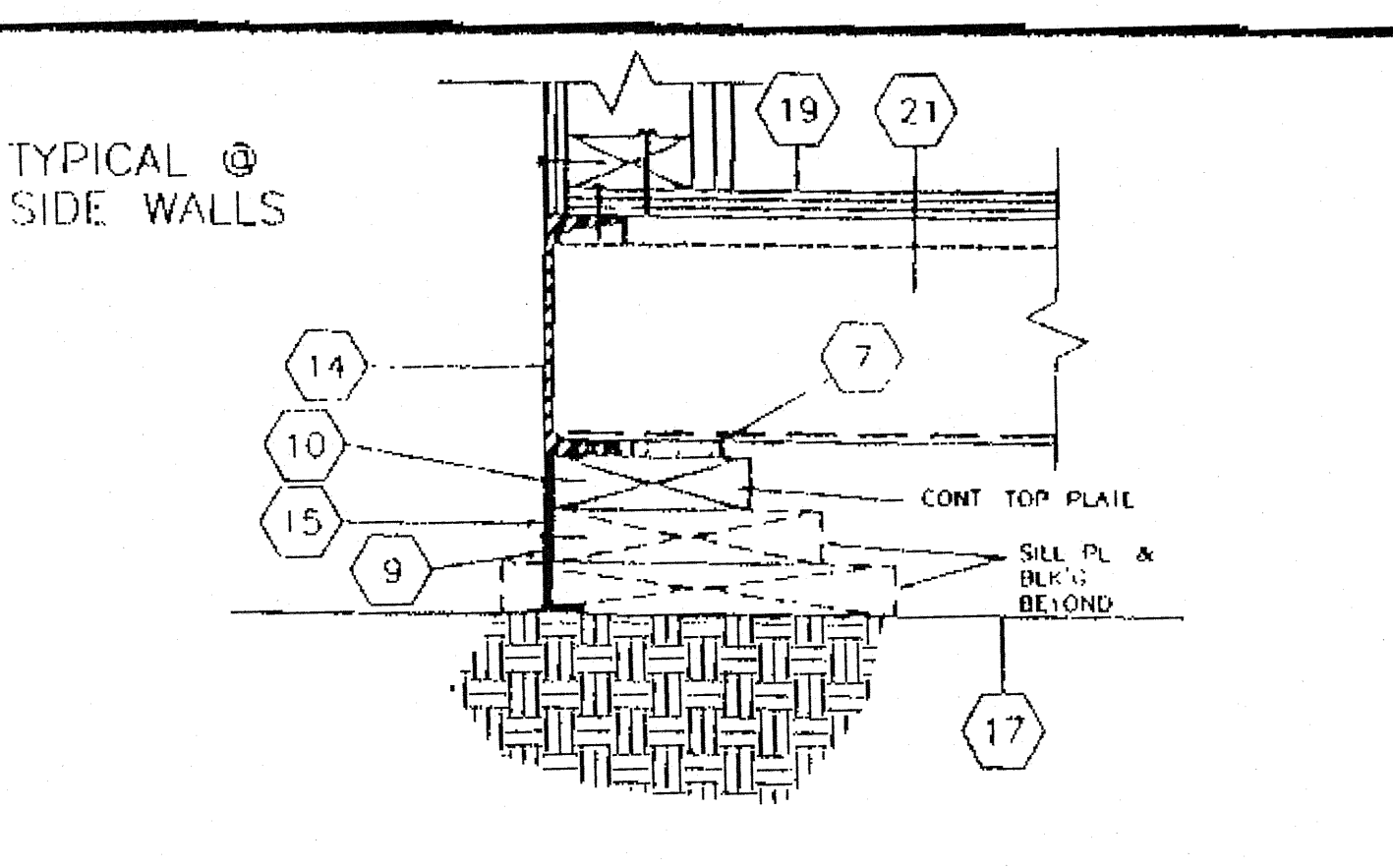

1 SCALE: NTS  
FOUNDATION VENT

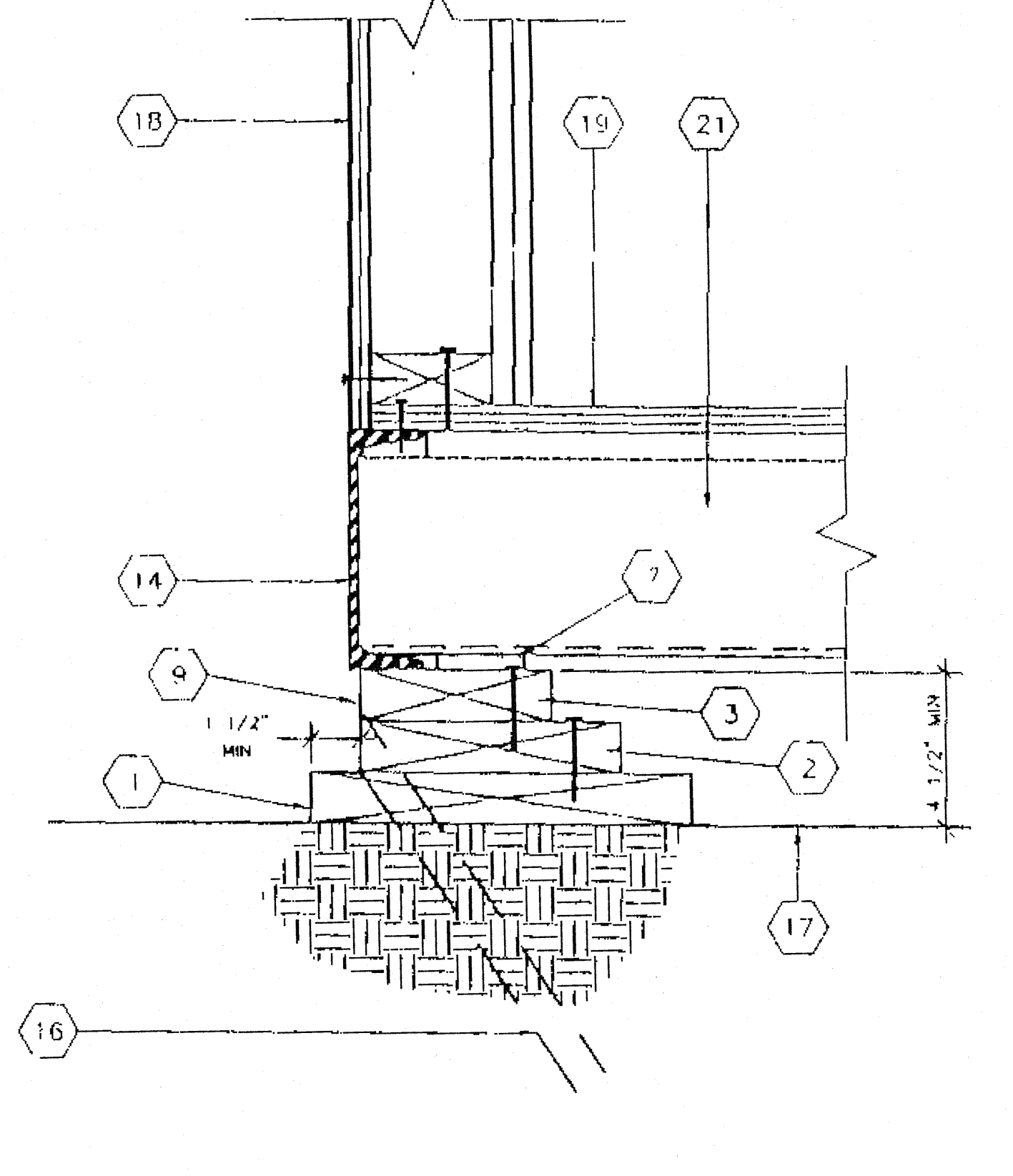

2 SCALE: 3"=1'-0"  
FOUNDATION @ SIDE WALL

**KEY NOTES**

- 1 2X12 SILL PLATE SEE FOUND. PLAN FOR LENGTH
- 2 2X8 BLOCKING W/16d @ MAX 5" O.C. TO SILL PLATE
- 3 2X6 TOP PLATE W/16d @ MAX 5" O.C. TYP. BLOCKING
- 4 2X4 TOP PLATE W/16d @ MAX 5" O.C. TO BLOCKING
- 5 2X4 BLOCKING W/16d MAX 5" O.C. TO SILL PLATE
- 6 2X6 SILL PLATE SEE FOUND. PLAN FOR LENGTH
- 7 5/8"x2 1/2" SHIM (WHEN REQ)
- 8 INSERT REQ'D 2X4 BLK'NG OR PLYWD. SHIM W/16d @ 12" O.C. FACE NAIL
- 9 OPTIONAL - MIN. 3/8" PLYWOOD SHIRTING W/ 10d @ MIN. 4" O.C. @ ENDWALLS & 6" O.C. @ SIDEWALLS E.N. & TYP. 12" O.C. FN. PLATE TO PLATE NAILING FOR THE FOUNDATION MEMBERS CAN BE DECREASED TO 12" O.C. AND FOUNDATION BLOCKING SHALL BE RECESSED SUCH THAT THE SHIRTING SHALL BE INSTALLED FLUSH WITH THE PERIMETER FLOOR CHANNEL.
- 10 10d GALV. NAIL @ MAX. 4" O.C.
- 11 2X12x2'-6" SILL PLATE SEE FOUND. PLAN FOR QUANTITY REQ'D
- 12 2 X 10 PLATES W/ 2-16D BOX @ 6" O.C.
- 13 2X10 BLK'NG FACE OR TOE NAIL 16d @ MAX 12" O.C. ADD BLKS. OR SHIMS AS REQ'D
- 14 FLOOR FRAME BEAM SEE STRUCTURAL
- 15 TYPICAL FOUNDATION VENT (SEE FOUNDATION PLAN FOR SIZES AND LOCATIONS).
- 16 SILL RESTRAINT 1" @ PIPE SEE FOUND FOR LOCATION
- 17 FINISH GRADE
- 18 EXTERIOR FINISH
- 19 PLYWOOD SUBFLOOR
- 20 MOD-LINE
- 21 FLOOR-JOIST
- 22 4"x12"x10 GA. PLATE
- 23 6"x12"x10 GA. PLATE
- 24 1 4" @ S.T.S. TYP. 4-PLACES
- 25 1 4" @ X3" LG. LAG SCREW TYP. 4-PLACES
- 26 5, 8" @ X4" LAGS (FOR LOCATION SEE PLAN)

FOUNDATION LUMBER TO BE PRECUT AT FACTORY, LUMBER GRADES & PRESSURE TREATING TO BE VERIFIED BY IMPLANT INSPECTOR

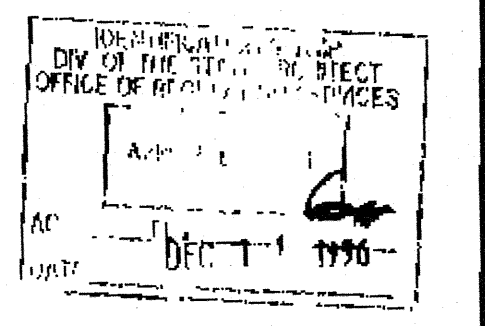

REVISIONS

ELECTRICAL

MECHANICAL

STRUCTURAL

ARCHITECT

DIVISION OF THE STATE ARCHITECT  
**REVISED**  
 DIVISION OF THE STATE ARCHITECT  
 19775  
 7-19-96

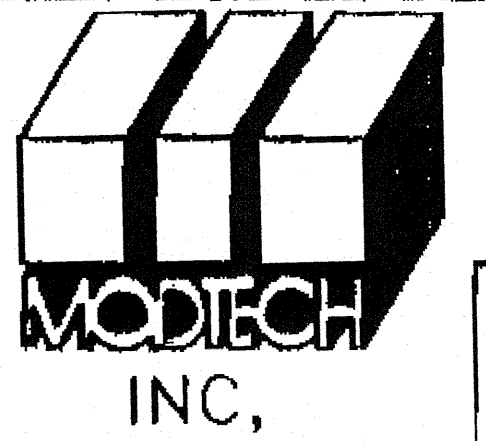

MODTECH INC.  
 2830 BARRETT AVE  
 PERRIS, CA. 92512  
 PH. (909) 943-4014  
 FX. (909) 940-0427

JOB NO.  
 IDENTIFICATION STAMP  
 DIV. OF THE STATE ARCHITECT  
 APPROX 15690  
 7/24/96

DRAWN BY  
 DATE  
 CHECKED BY  
 DATE  
**F3.0**

CONFIDENTIAL - THIS DOCUMENT AND THE INFORMATION CONTAINED HEREIN ARE THE PROPERTY OF MODTECH INC. UNAUTHORIZED COPYING, DISCLOSURE, OR OTHER UNAUTHORIZED USES ARE PROHIBITED.

**FOUNDATION DETAILS**

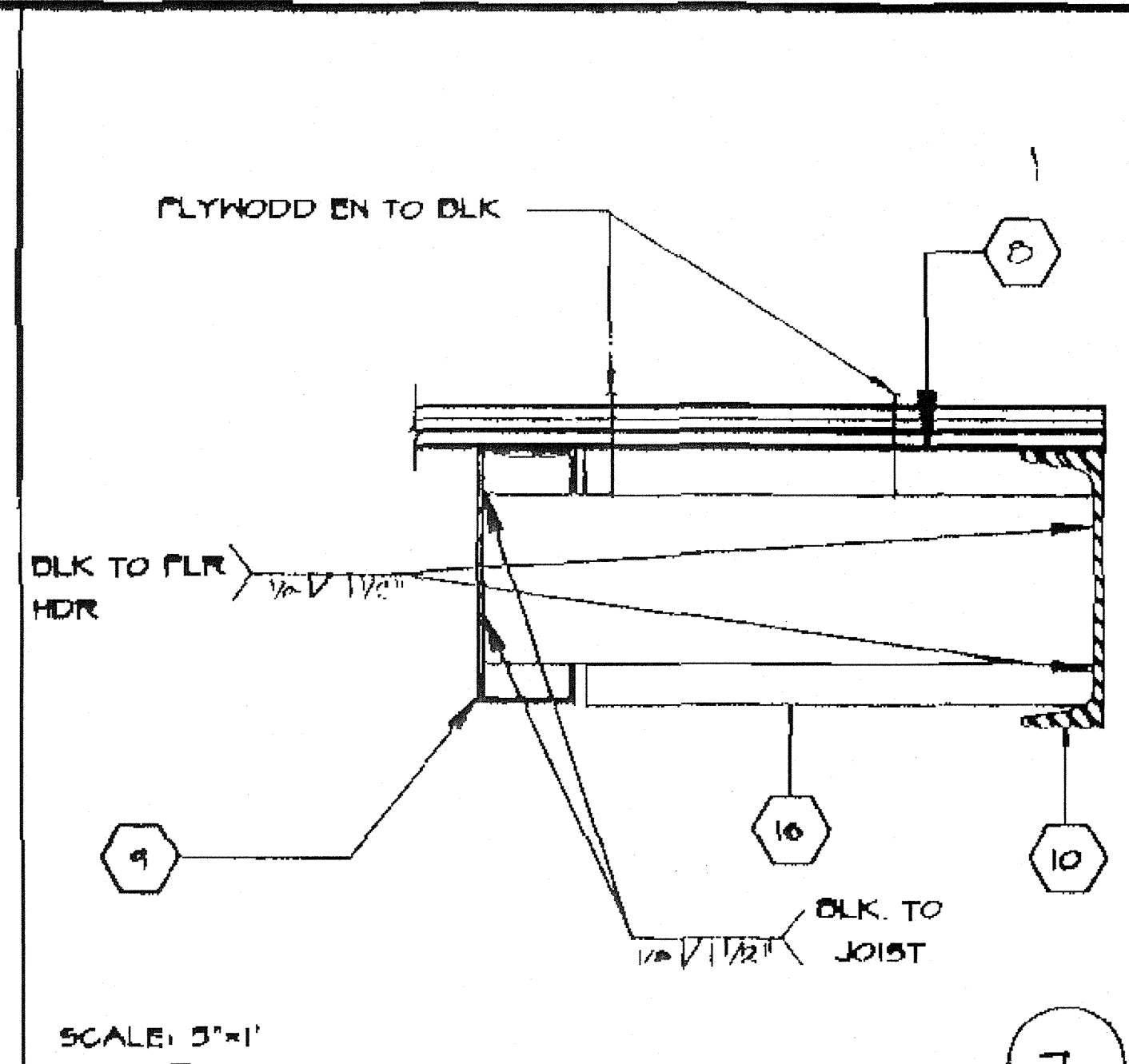

SCALE: 3\"/>

BLOCK @ MIDSPAN

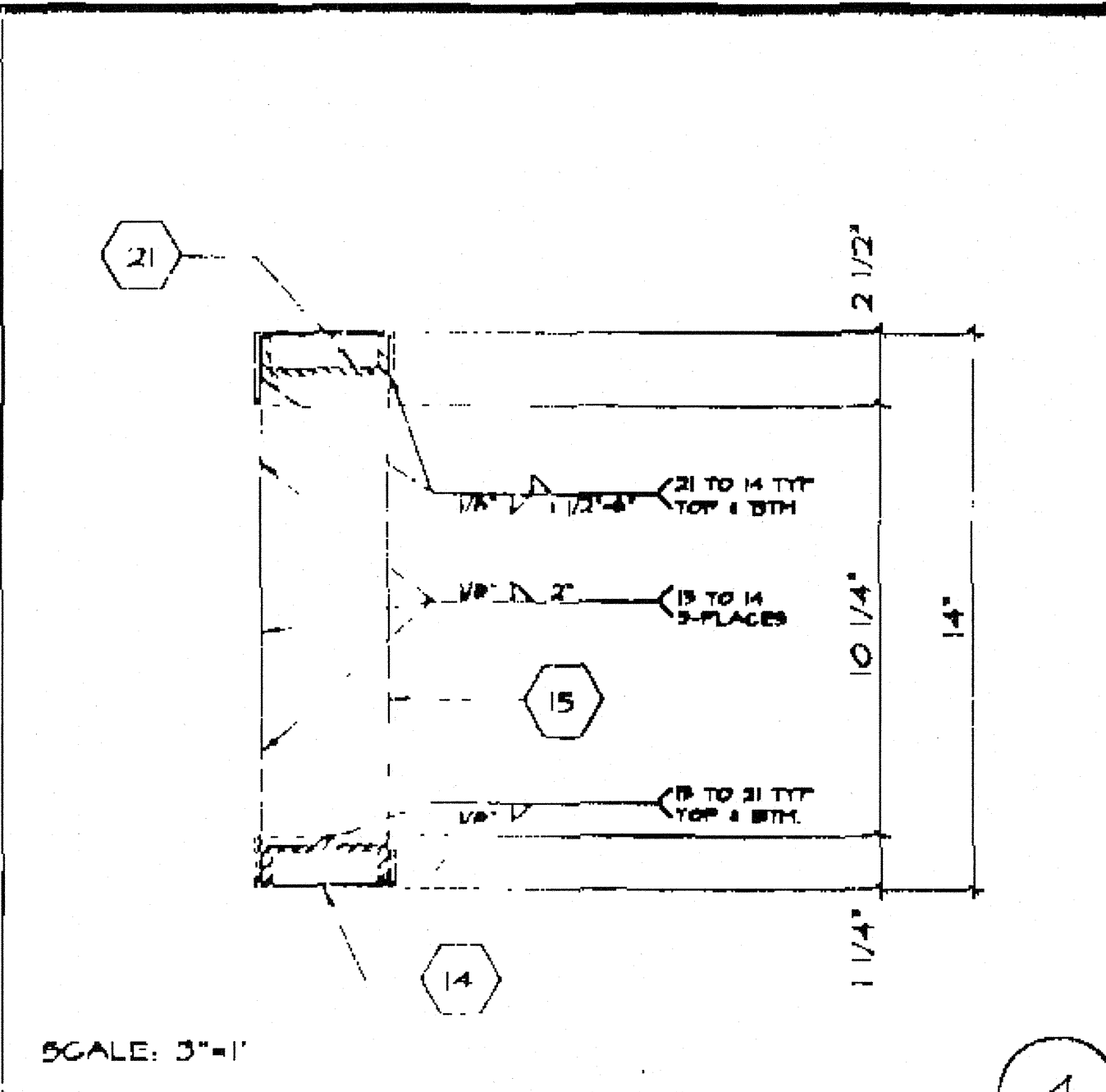

SCALE: 3\"/>

MECH. DUCT OPENING IN HEADER

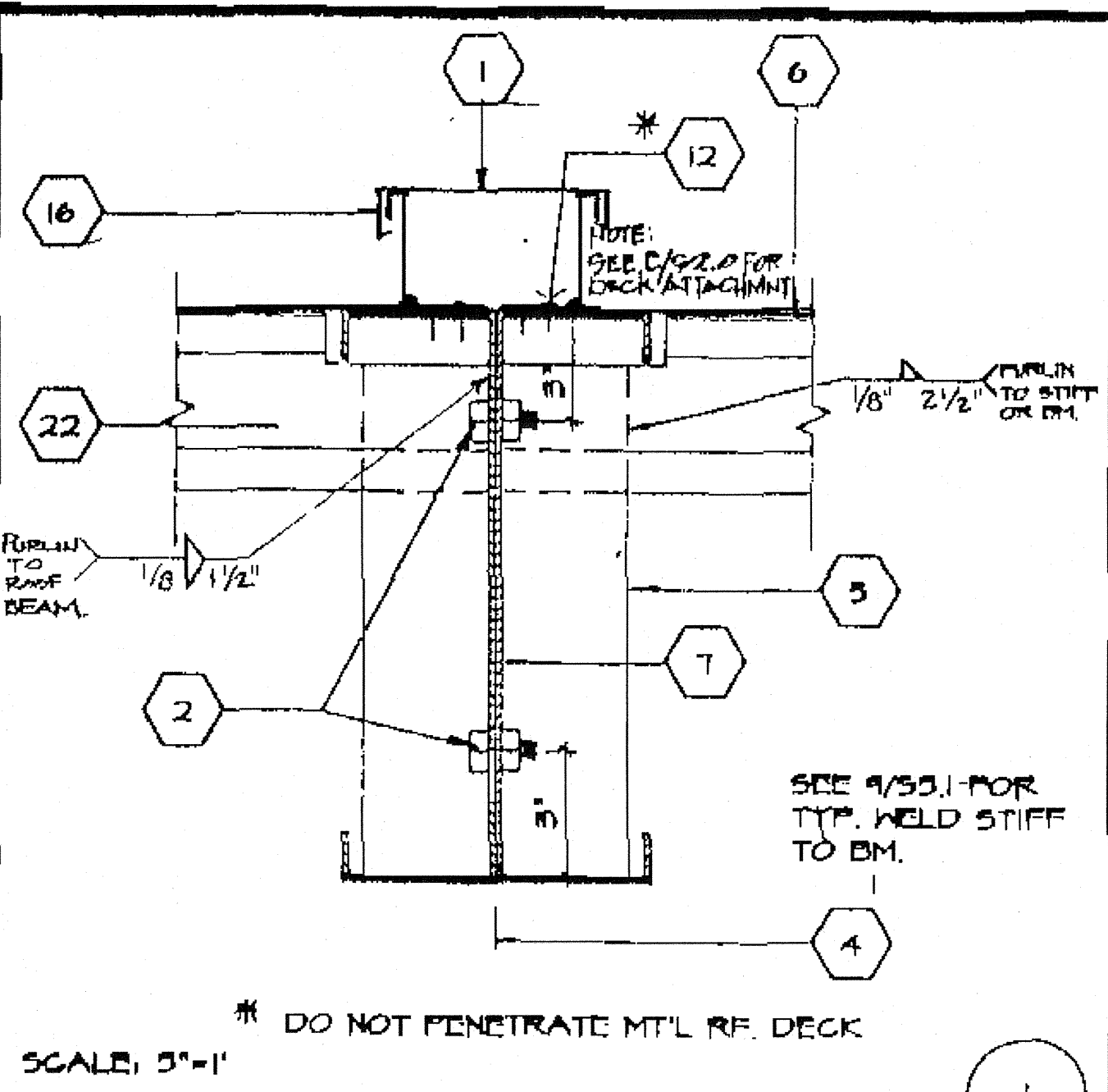

SCALE: 3\"/>

ROOFING @ MODLINE

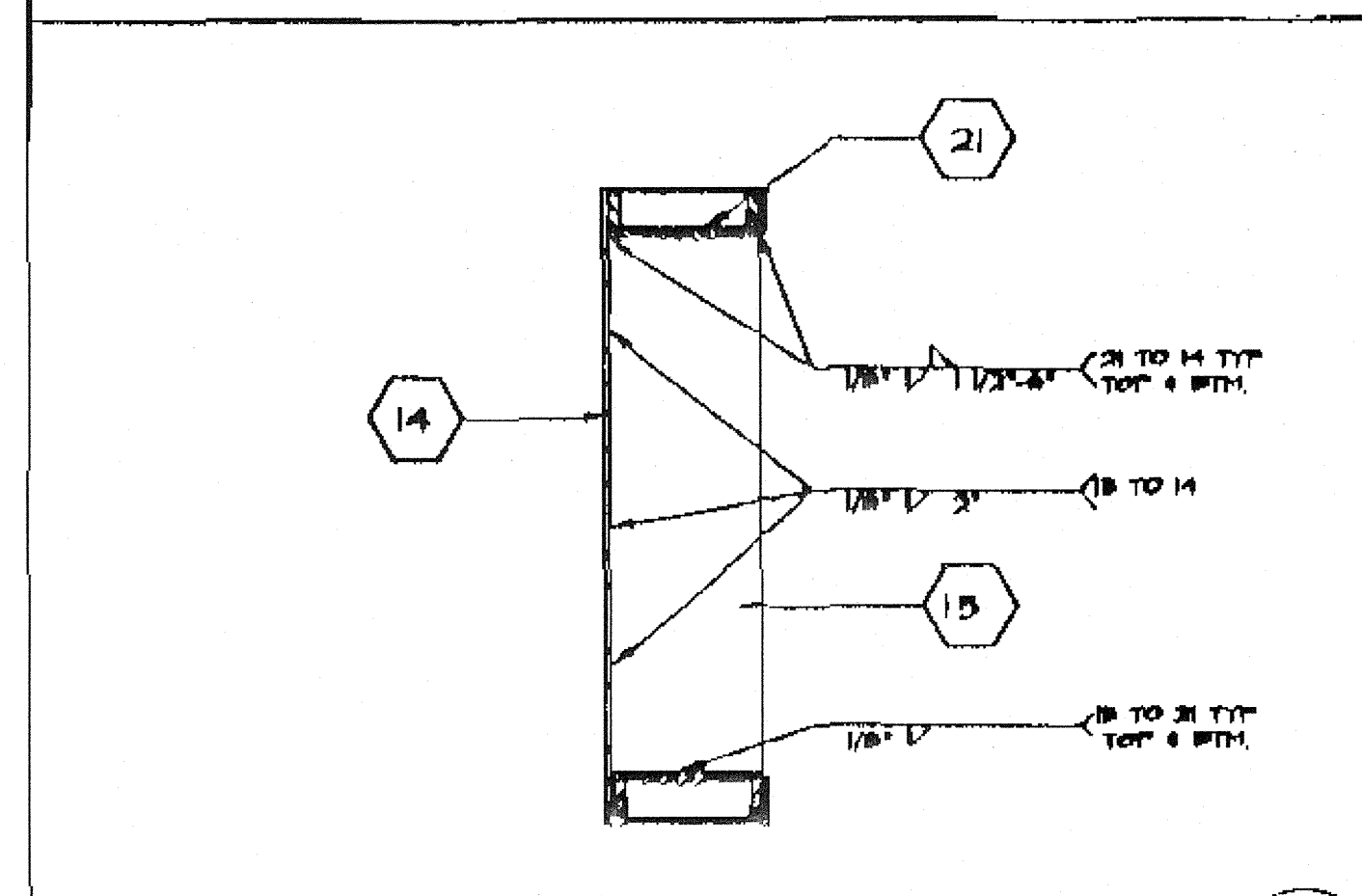

SCALE: 3\"/>

HEADER REINF. @ A.C. OPENING

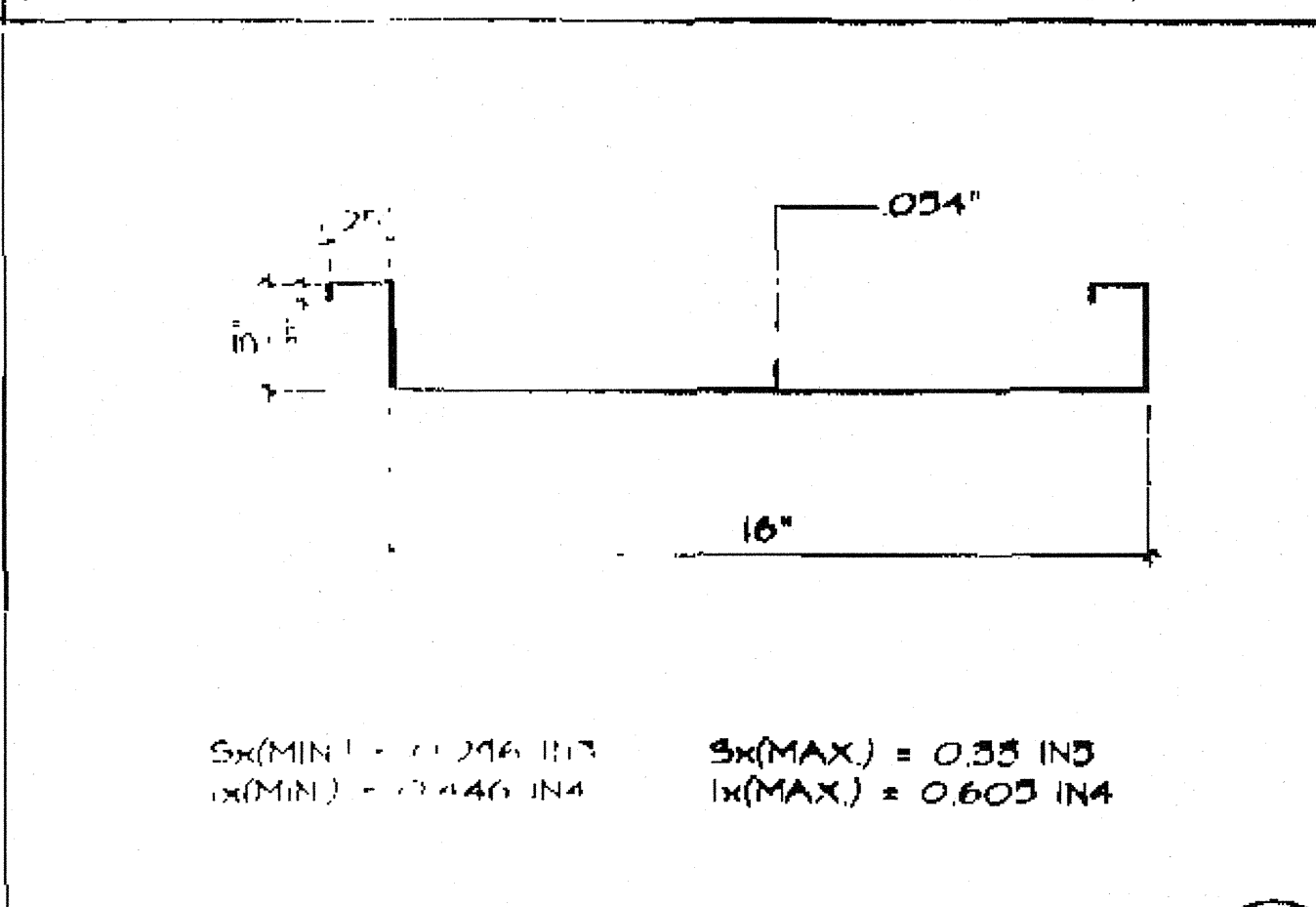

SCALE: 3\"/>

ROOF PAN (22GA)

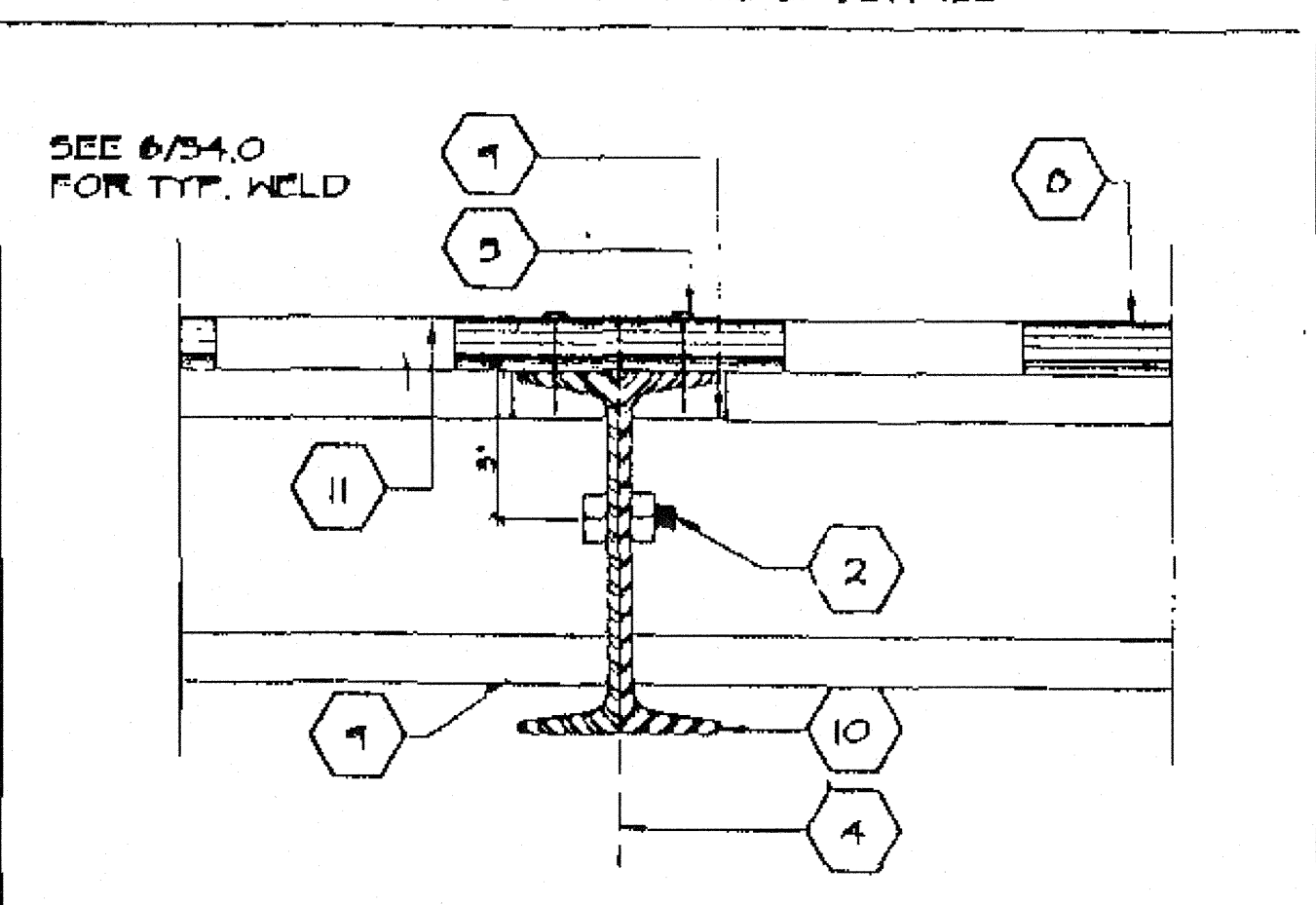

SCALE: 3\"/>

MODULE JOINT @ FLR. 12'-0"

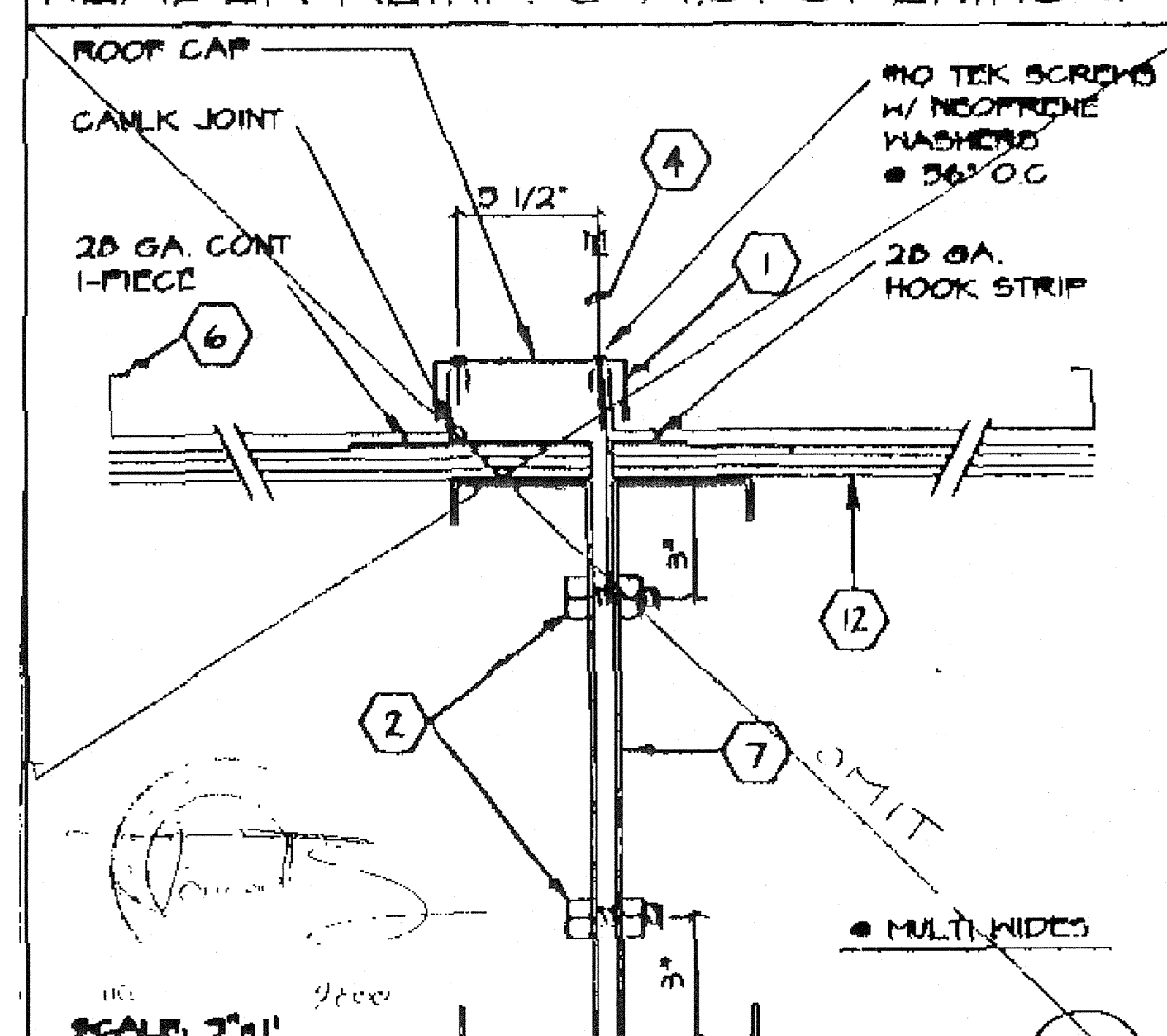

SCALE: 3\"/>

ALT. ROOFING @ MODLINE

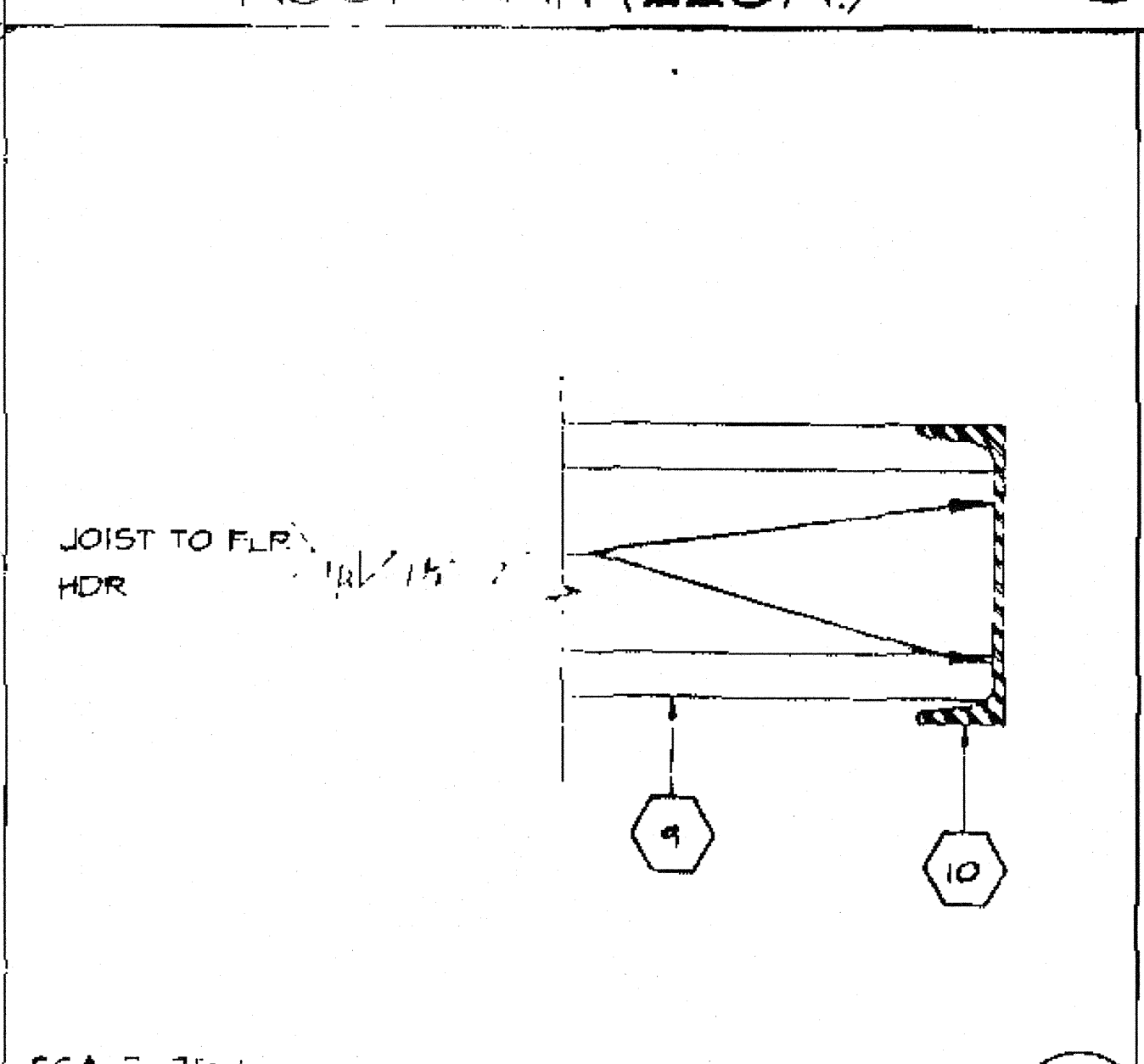

SCALE: 3\"/>

FLOOR NAME/JOIST TO BEAM

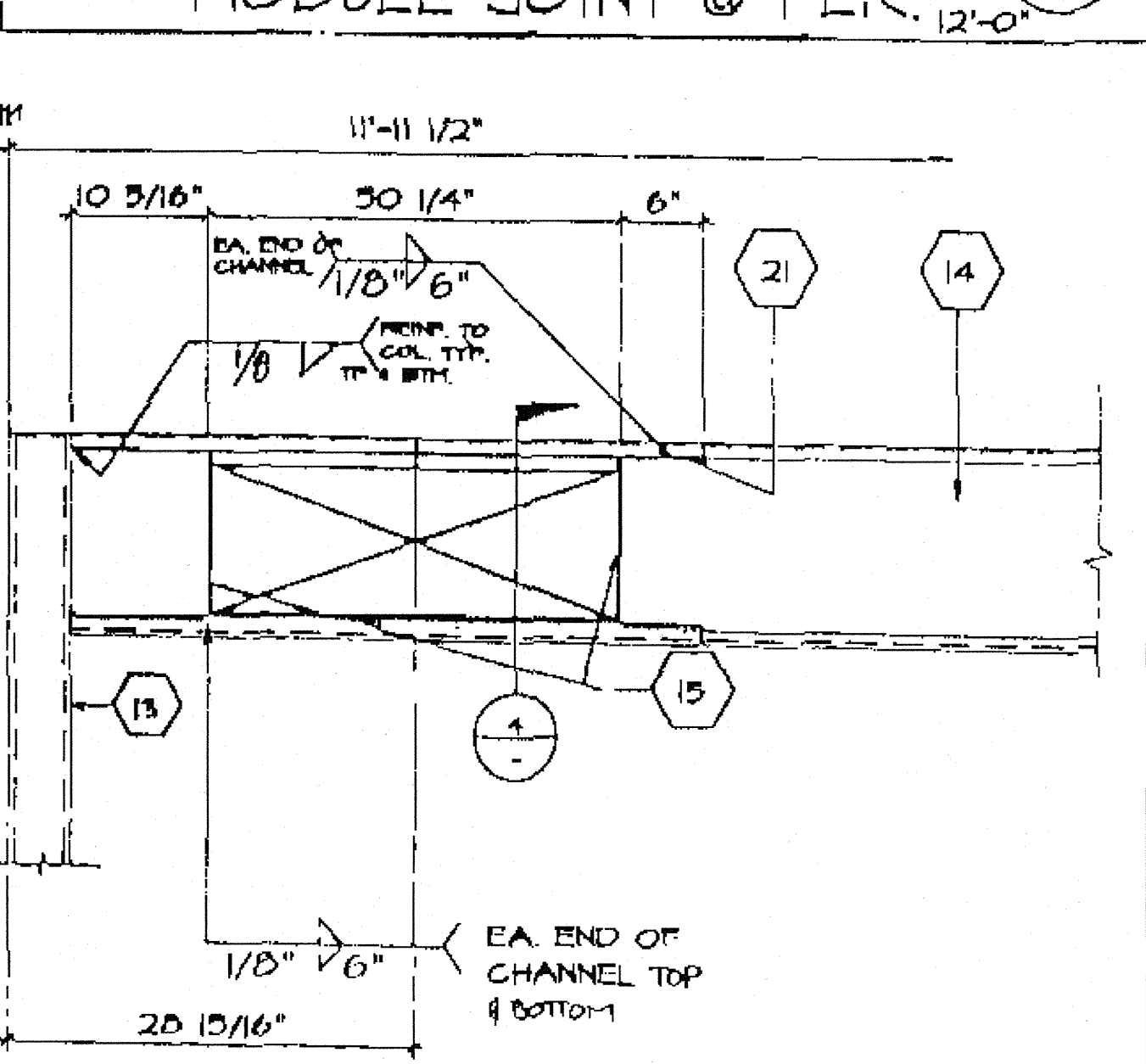

SCALE: 1\"/>

ELEVATION-OPENING

KEY NOTES

- 1 CAP CLOSURE @ MODLINE 26GA. GALV. W/10 TYPE FASTENERS W/NEOPRENE WASHERS TO RID BOTH SIDES OF MODLINE SET CAP IN SEALANT
- 2 5/8" M.B. A307 MODULE JOINT (SEE STRUCTURAL PLAN FOR LOCATION) @ 0" O.C.
- 3 EN
- 4 MODULE JOINT
- 5 1/4" @ 0" O.C. FULL DEPTH STIFFENER PLATE (SEE 4/52.1)
- 6 STANDING SEAM ROOF (SEE A2.0)
- 7 ROOF BEAM (SEE STRUCTURAL) SEE 3/52.1 & 12/52.1
- 8 PLYWOOD FLOOR SHEATHING
- 9 FLOOR JOIST 6/52.1
- 10 FLOOR BEAM (SEE STRUCTURAL 3/52.1)
- 11 HAND-HOLE @ BOLT LOCATION
- 12 #14 STGMS
- 13 3 1/2"x3 1/2"x1/4" STEEL TUBE COLUMN
- 14 ROOF HEADER (SEE STRUCTURAL 1/52.1)
- 15 1/4" STIFFENER PLATE SEE 4/52.1 FOR TYP. HELL
- 16 CAP CLOSURE AT RIDGE 26GA. GALV. W/10 STGMS AT 48" O.C. W/NEOPRENE WASHER TO RID SET BOTH SIDES OF CAP IN SEALANT
- 17 NOT USED
- 18 NOT USED
- 19 NOT USED
- 20 2"x2"x3/16" L
- 21 3 1/4"x1"x45 11/16" L X10GA CHANNEL TOP & BOTTOM CENTER OF OPENING
- 22 ROOF FURLIN SEE 2/52.1
- 23 TUBE STEEL (SEE NOTE #13)

IDENTIFICATION STAMP  
DIV. OF THE STATE ARCHITECT  
APPROX 115000  
AC / PLS / SS / TB  
DATE DEC 11 1998

DATE DEC 11 1998

ARCHITECT

ELECTRICAL

STRUCTURAL

MECHANICAL

FIRE MARSHAL

ACCESS COMPLIANCE

STRUCTURAL SAFETY

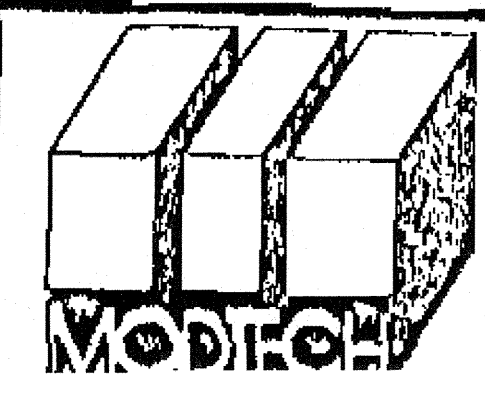

© MODTECH INC. 1994

DRAWN BY  
DATE  
CHECKED BY  
DATE

S1.0

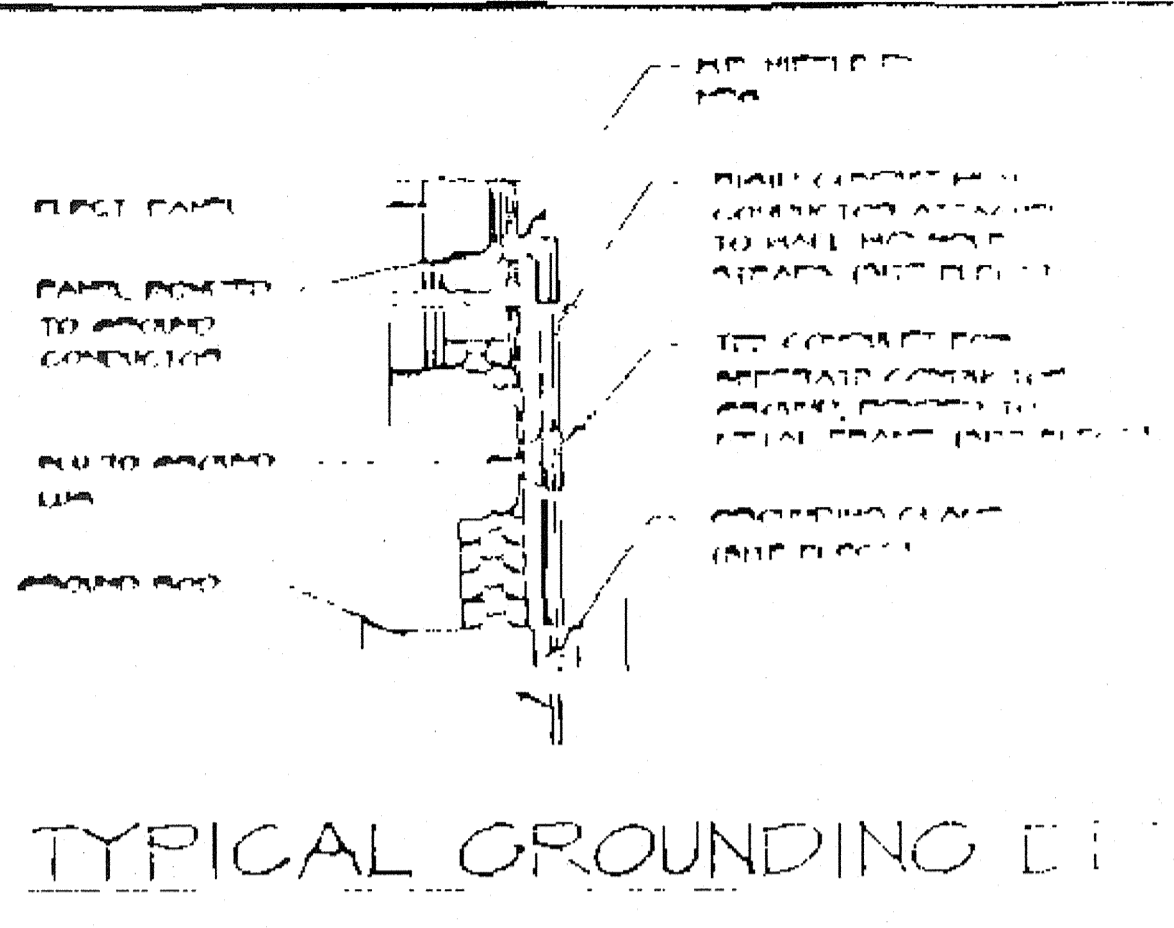
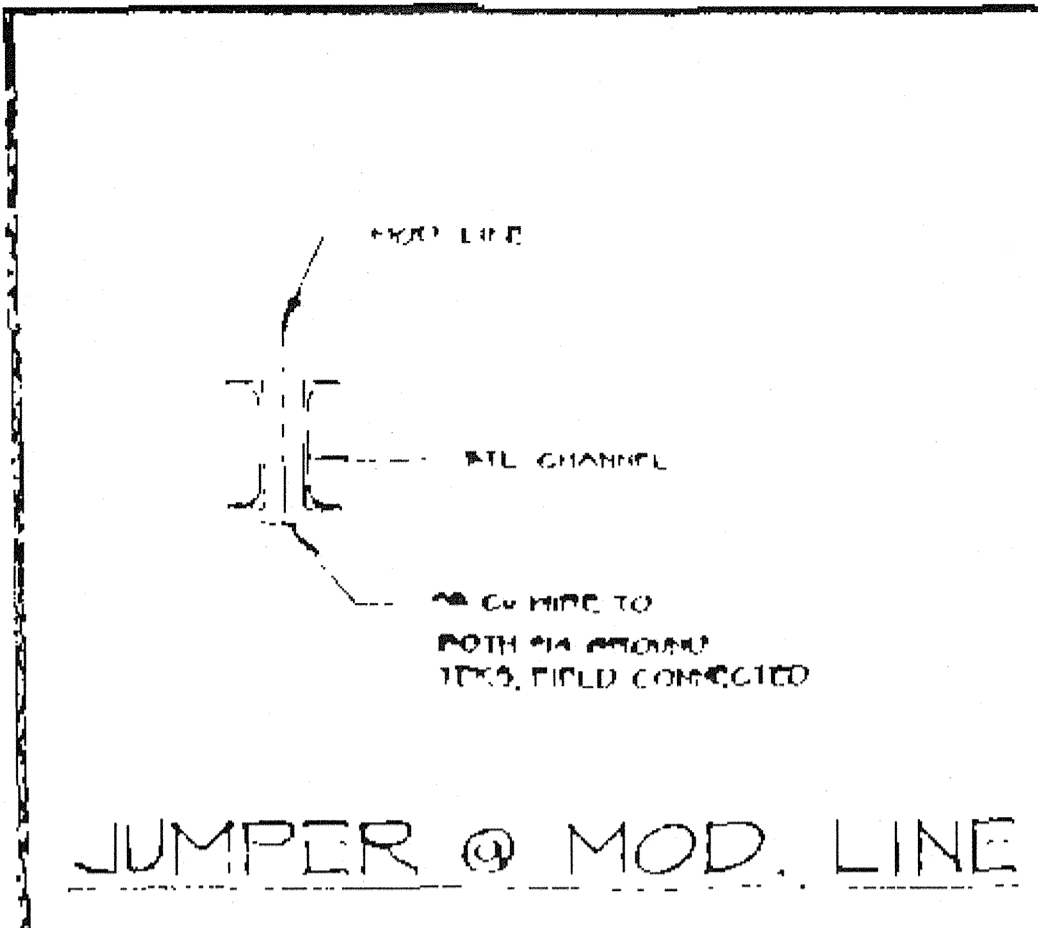

1. WALL PENETRATIONS SHALL BE COMPLETELY PROTECTED BY A QUALIFIED CONTRACTOR AT THE TIME OF WORK. NO PENETRATIONS SHALL BE MADE IN A WALL OR CEILING AT AN ANGLE NOT TO EXCEED 45 DEGREES FROM THE VERTICAL OR SHALL BE MADE IN A MANNER THAT WILL LEAK AIR OR WATER INTO THE BUILDING.

2. PENETRATIONS SHALL BE PROTECTED BY AN IMPERMEABLE MATERIAL AT LEAST ONE INCH ABOVE AND ONE INCH BELOW THE PENETRATION.

3. APPROVAL OF THE DRAWING SHALL BE REQUIRED PRIOR TO THE APPROVAL OF THE ARCHITECT. THE ARCHITECT SHALL BE REQUIRED TO PROVIDE THE NECESSARY INFORMATION FOR THE CONTRACTOR TO COMPLETE THE WORK IN ACCORDANCE WITH THE APPROVAL.

SYMBOL	DESCRIPTION	QTY
[Symbol]	4' X 6' ALUMINUM CLOSETTING CLOSER	
[Symbol]	1" DIA. MOUNTING HOOK	
[Symbol]	1/2" DIA. MOUNTING HOOK	
[Symbol]	1/2" DIA. MOUNTING HOOK	
[Symbol]	1/2" DIA. MOUNTING HOOK	
[Symbol]	1/2" DIA. MOUNTING HOOK	
[Symbol]	1/2" DIA. MOUNTING HOOK	
[Symbol]	1/2" DIA. MOUNTING HOOK	
[Symbol]	1/2" DIA. MOUNTING HOOK	
[Symbol]	1/2" DIA. MOUNTING HOOK	
[Symbol]	1/2" DIA. MOUNTING HOOK	
[Symbol]	1/2" DIA. MOUNTING HOOK	
[Symbol]	1/2" DIA. MOUNTING HOOK	
[Symbol]	1/2" DIA. MOUNTING HOOK	
[Symbol]	1/2" DIA. MOUNTING HOOK	
[Symbol]	1/2" DIA. MOUNTING HOOK	
[Symbol]	1/2" DIA. MOUNTING HOOK	

- NOTES**
1. 4" DIA. HEATED ROOF OUTLET BOX 1/2 (SEE SPEC)
  2. HVAC UNIT (SEE SPEC)
  3. ELECTRICAL PANEL "A"
  4. EXTERIOR LIGHT FIXTURE
  5. 1/2" DIA. MOUNTING HOOK FOR BIRD ALARM OR BELL
  6. DUPLEX WALL RECEPTACLE IS-A 125-V 2-PHASE
  7. CLOCK OUTLET (SEE SPEC)
  8. 2' X 4' FLUORESCENT LIGHT AND FIXTURE 4-BAY (SEE SPEC)

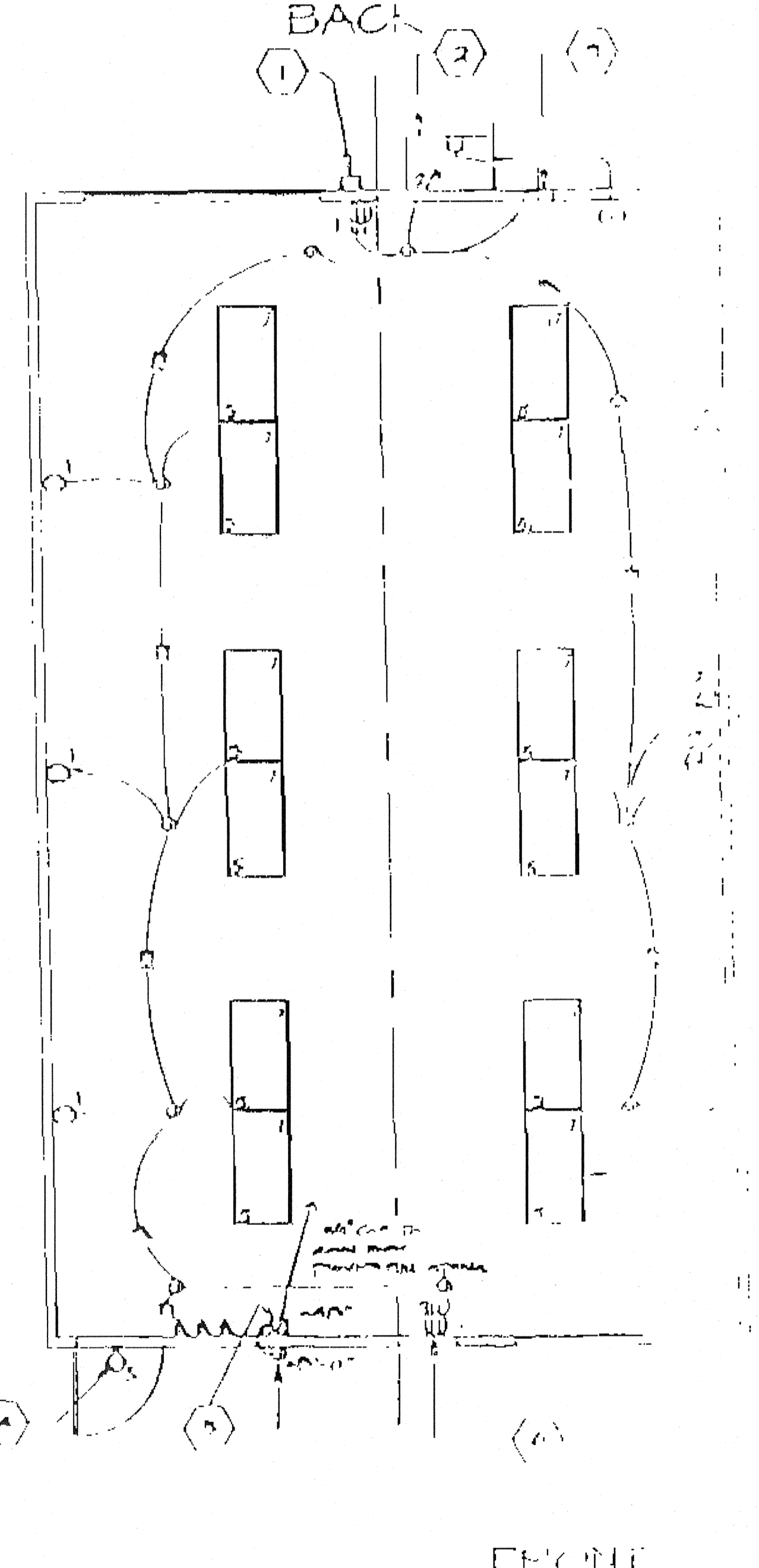

VOLTS	AMP	WATT	VA	REACTANCE	IMPEDANCE	PHASE	REMARKS
120	10	1200	1360	0	12	1	RECEPTACLE
120	20	2400	2720	0	24	2	RECEPTACLE
120	15	1800	2040	0	18	1	RECEPTACLE
120	20	2400	2720	0	24	2	RECEPTACLE
120	10	1200	1360	0	12	1	RECEPTACLE
120	20	2400	2720	0	24	2	RECEPTACLE
120	15	1800	2040	0	18	1	RECEPTACLE
120	20	2400	2720	0	24	2	RECEPTACLE
120	10	1200	1360	0	12	1	RECEPTACLE
120	20	2400	2720	0	24	2	RECEPTACLE
120	15	1800	2040	0	18	1	RECEPTACLE
120	20	2400	2720	0	24	2	RECEPTACLE
120	10	1200	1360	0	12	1	RECEPTACLE
120	20	2400	2720	0	24	2	RECEPTACLE
120	15	1800	2040	0	18	1	RECEPTACLE
120	20	2400	2720	0	24	2	RECEPTACLE
120	10	1200	1360	0	12	1	RECEPTACLE
120	20	2400	2720	0	24	2	RECEPTACLE
120	15	1800	2040	0	18	1	RECEPTACLE
120	20	2400	2720	0	24	2	RECEPTACLE
120	10	1200	1360	0	12	1	RECEPTACLE
120	20	2400	2720	0	24	2	RECEPTACLE
120	15	1800	2040	0	18	1	RECEPTACLE
120	20	2400	2720	0	24	2	RECEPTACLE
120	10	1200	1360	0	12	1	RECEPTACLE
120	20	2400	2720	0	24	2	RECEPTACLE
120	15	1800	2040	0	18	1	RECEPTACLE
120	20	2400	2720	0	24	2	RECEPTACLE
120	10	1200	1360	0	12	1	RECEPTACLE
120	20	2400	2720	0	24	2	RECEPTACLE
120	15	1800	2040	0	18	1	RECEPTACLE
120	20	2400	2720	0	24	2	RECEPTACLE
120	10	1200	1360	0	12	1	RECEPTACLE
120	20	2400	2720	0	24	2	RECEPTACLE
120	15	1800	2040	0	18	1	RECEPTACLE
120	20	2400	2720	0	24	2	RECEPTACLE
120	10	1200	1360	0	12	1	RECEPTACLE
120	20	2400	2720	0	24	2	RECEPTACLE
120	15	1800	2040	0	18	1	RECEPTACLE
120	20	2400	2720	0	24	2	RECEPTACLE

- MOUNTING HEIGHTS**
- RECEPTACLE 48" MIN.
  - SWITCHES 48" MIN.
  - EXTERIOR LIGHT 4'6"
  - INTERIOR LIGHT 7'6" MAX
  - CLOCK 48"
  - MAIN PANEL BOX 4'6"
  - SWITCHES 4'6" MAX

**SCHOOL EQUIPMENT ANCHORAGE**

THE FOLLOWING IS FOR THE ELECTRICAL ENGINEER'S INFORMATION ONLY.

THE SEISMIC ANCHORAGE OF ELECTRICAL EQUIPMENT SHALL CONFORM TO A.C.I. TITLE 31, SECTION 1913.1 AND TABLE 1913.1. ANCHORAGE DETAILS FOR FOOT CLOSURE SHOWN FOR THIS PROJECT SHALL BE PROVIDED BY THE ENGINEER. ITEMS SHALL BE ANCHORED THROUGH THE CLAY TO THE CONCRETE BELOW.

**FOR ELECTRICAL DRAWINGS:**

ALL ELECTRICAL EQUIPMENT SHALL BE BRACED OR ANCHORED TO RESIST A SEISMIC FORCE ACTING IN ANY DIRECTION USING THE FOLLOWING CRITERIA:

FOR 120V/20A	20% OF OPERATING WEIGHT
FOR 240V/20A	30% OF OPERATING WEIGHT

THE SEISMIC FORCE SHALL BE 1.0 FOR ALL EQUIPMENT LESS THAN 100 LB AND 1.5 FOR EQUIPMENT GREATER THAN 100 LB. THE SEISMIC FORCE SHALL BE 1.0 FOR ALL EQUIPMENT LESS THAN 100 LB AND 1.5 FOR EQUIPMENT GREATER THAN 100 LB.

THE SEISMIC FORCE SHALL BE 1.0 FOR ALL EQUIPMENT LESS THAN 100 LB AND 1.5 FOR EQUIPMENT GREATER THAN 100 LB.

THE SEISMIC FORCE SHALL BE 1.0 FOR ALL EQUIPMENT LESS THAN 100 LB AND 1.5 FOR EQUIPMENT GREATER THAN 100 LB.

**ELECTRICAL PLAN**

"A" SHOWN  
 13" OPPOSITE  
 SCALE 1/4" = 1'-0"

ARCHITECT	ELECTRICAL	STRUCTURAL	MECHANICAL	FIRE MARSHAL	COMPLIANCE	STRUCTURAL SAFETY	IDENTIFICATION STAMP DIV. OF THE STATE ARCHITECT APPROV. 115600 AC: [Signature] PLS: [Signature] SS: TD DATE: 7/24/14 <b>E1.0A</b>

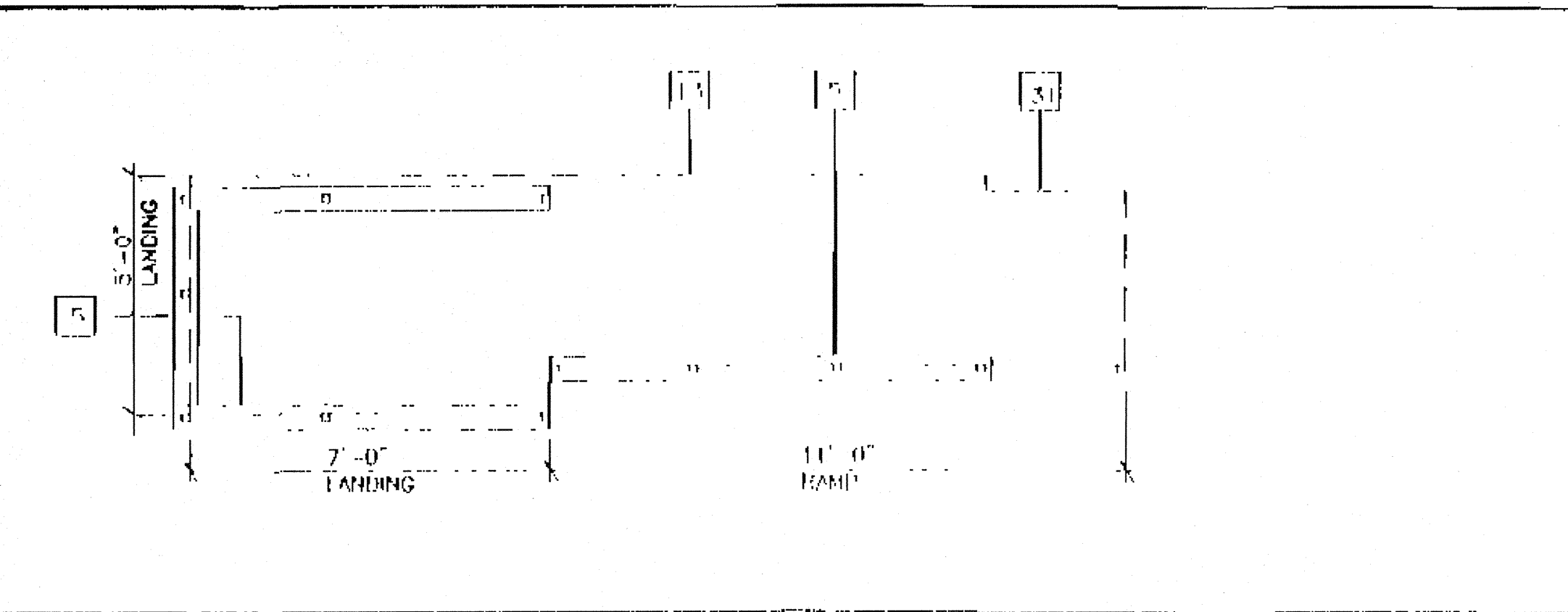
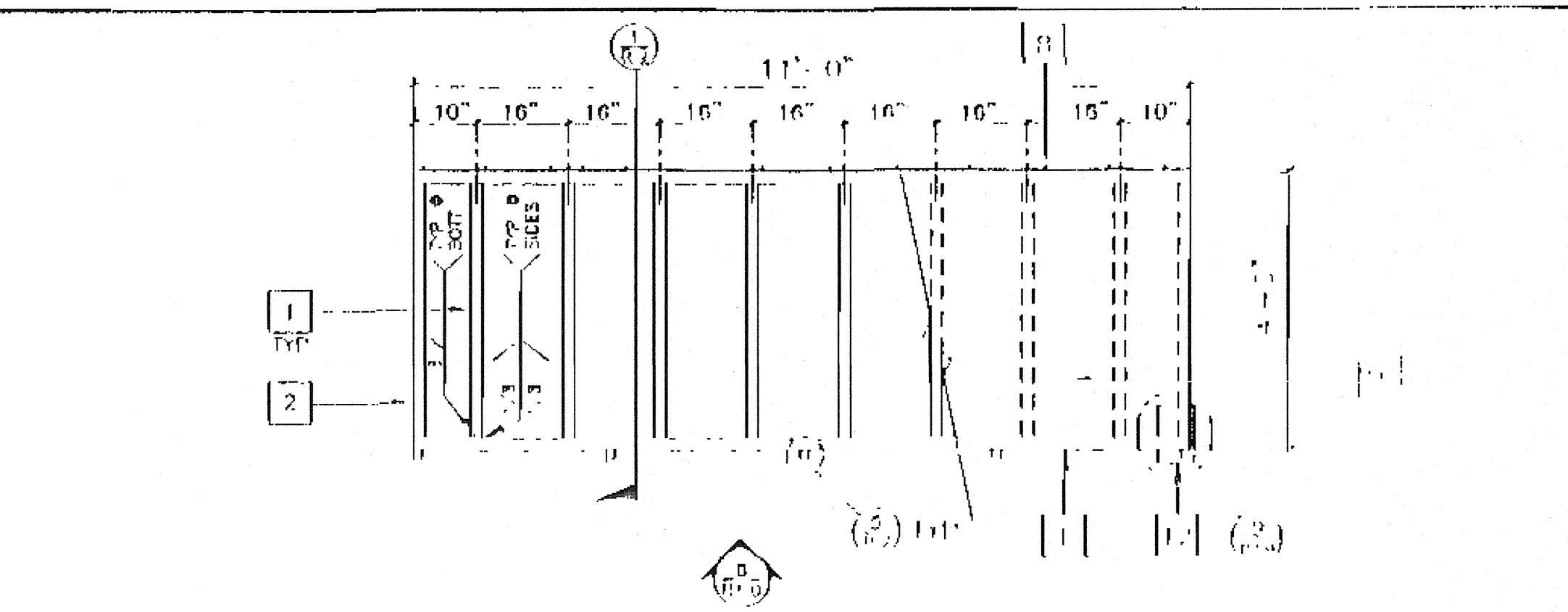
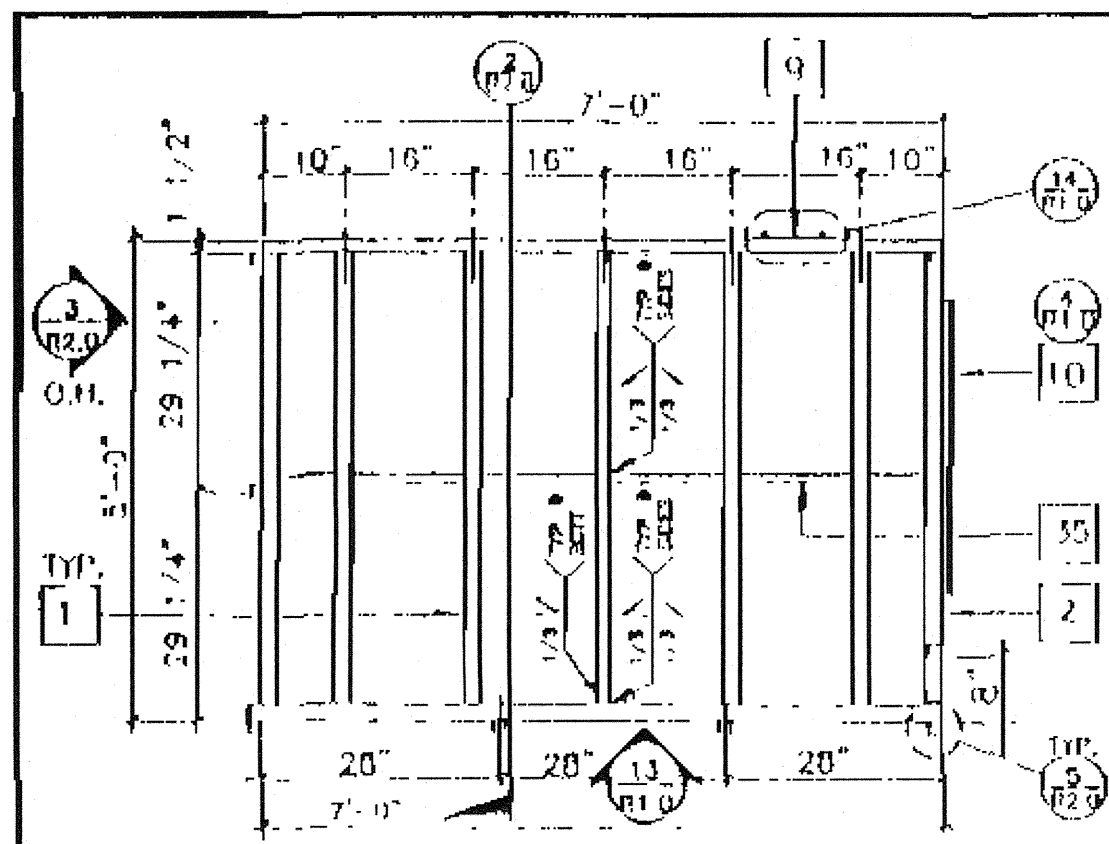

**KEY NOTES**

- 1 TS 2" x 2" x 14ga
- 2 TS 1 1/2" x 1 1/2" x 14ga (Fy = 39KSI)
- 4 TS 1" x 1" x 16ga WHEELCHAIR GUIDE
- 5 2 x 6 PI SILL PLATE
- 6 6" x 10ga CONT. PLATE W/ 1/4" x 2" TEK SCREWS @ 9" OC INTO WOOD OR FOUND. BLOCKS OR #14 x 2" TEK SCREWS INTO STEEL @ 9" OC
- 9 6" x 12" x 10ga PLATE W/ 2-1/4" x 3" LAGS TO STRUCTURAL FRAME OF BUILDING
- 10 3" x 1" x 3'-0" x 10ga BENT PLATE
- 11 2" x 4" x 12ga BASE PLATE W/ 2-1/4" x 1" LAGS
- 12 6" x 10" x 12ga BASE PLATE @ RAMP TOP
- 13 LINE OF RAMP/LANDING ABOVE
- 14 LOWER LANDING BY DISTRICT
- 15 SKINNING: PLYWOOD TO MATCH BUILDING SIDING. BLOCK ALL JOINTS. ATTACH W/ 7d @ 6" OC EDGES AND 12" OC FIELD. AT EDGE CONNECTION TO T.S. USE #14 x 2" TEK SCREWS @ 6" OC
- 16 12ga METAL DECK: NON-SLIP SURFACE. DESIGN COEFFICIENT OF FRICTION GREATER THAN 0.6. MAINTAINABLE FOR 1 YR.
- 17 RAMP EXTENSION FRAME.
- 20 EXISTING BUILDING.
- 27 RAMP BY MODTECH
- 28 FLUSH TRANSITION
- 31 NOTCH BOTTOM PLATE (MUD SILL) AS REQUIRED TO CLEAR RAMP TOP. MAX NOTCH 1 1/2" x 4'-0" LONG.
- 35 TS 1" x 1" x 10ga

LANDING FRAME 12

RAMP FRAME 7

SILL PLAN FOR RAMP AND LANDING 1

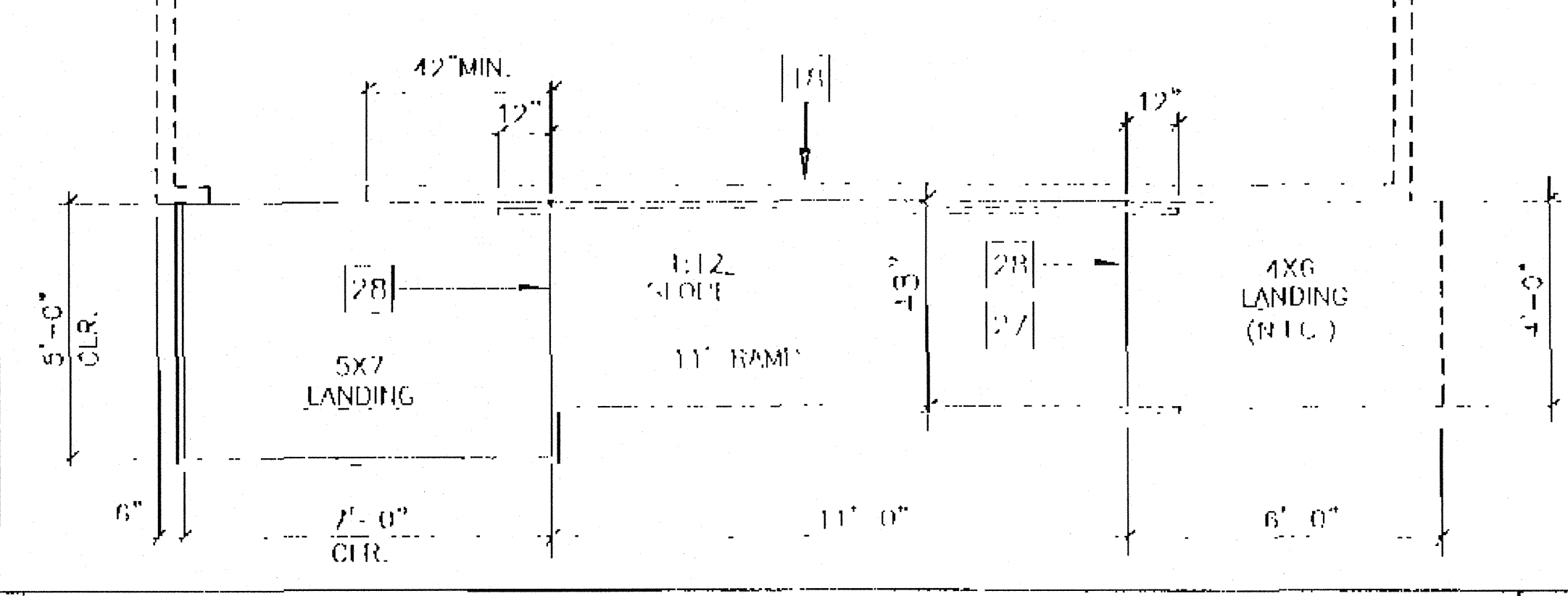
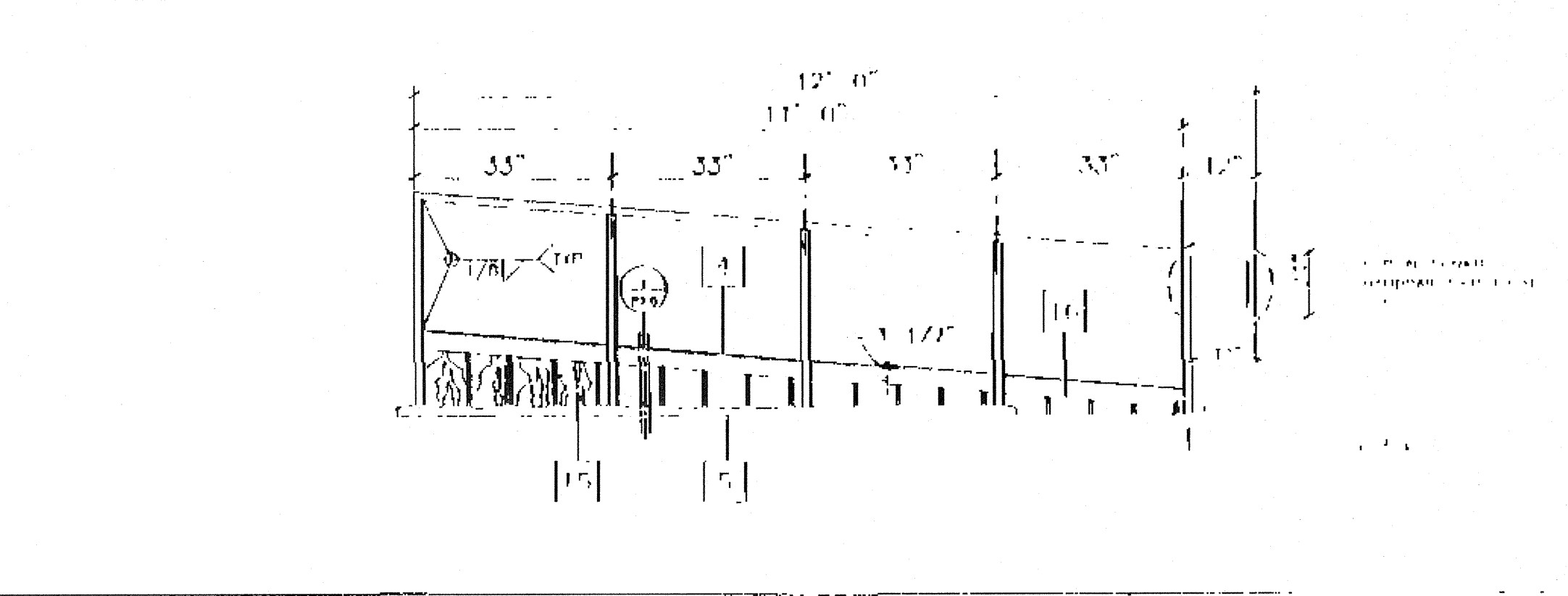
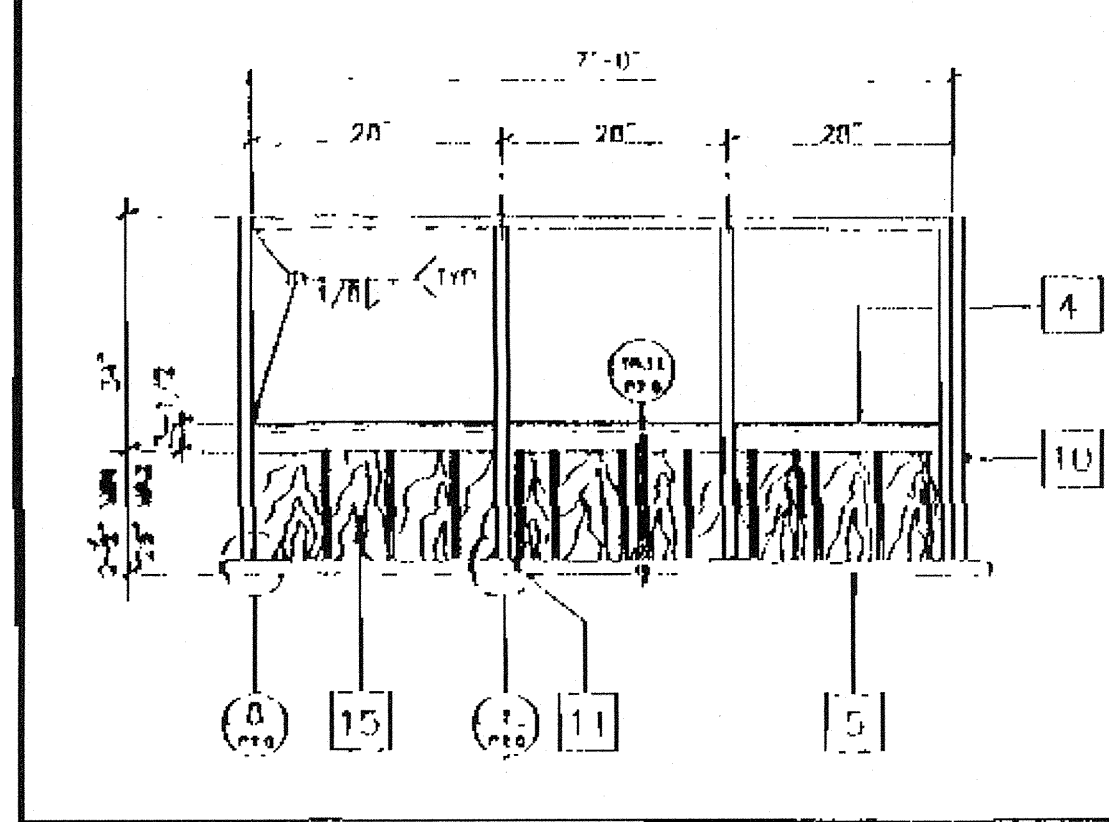

LANDING ELEVATION 13

RAMP ELEVATION 8

RAMP AND LANDING AT BUILDING 2

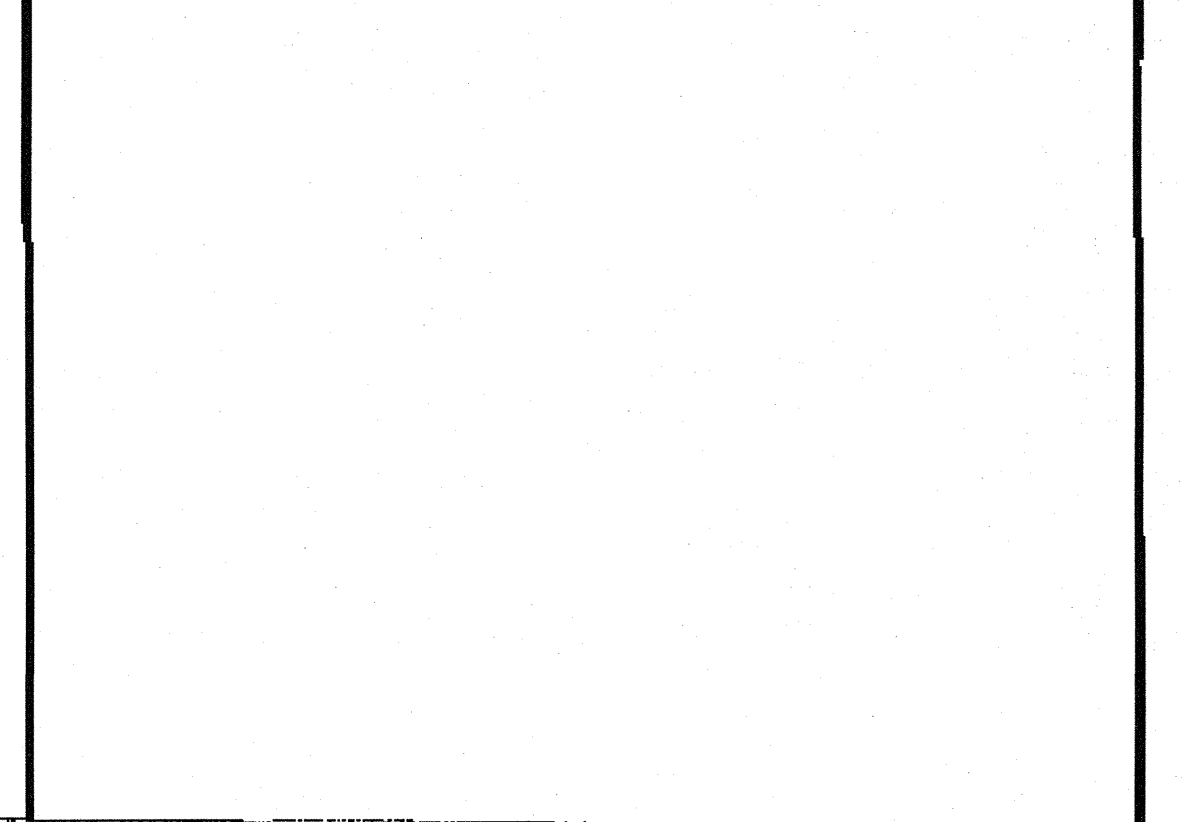
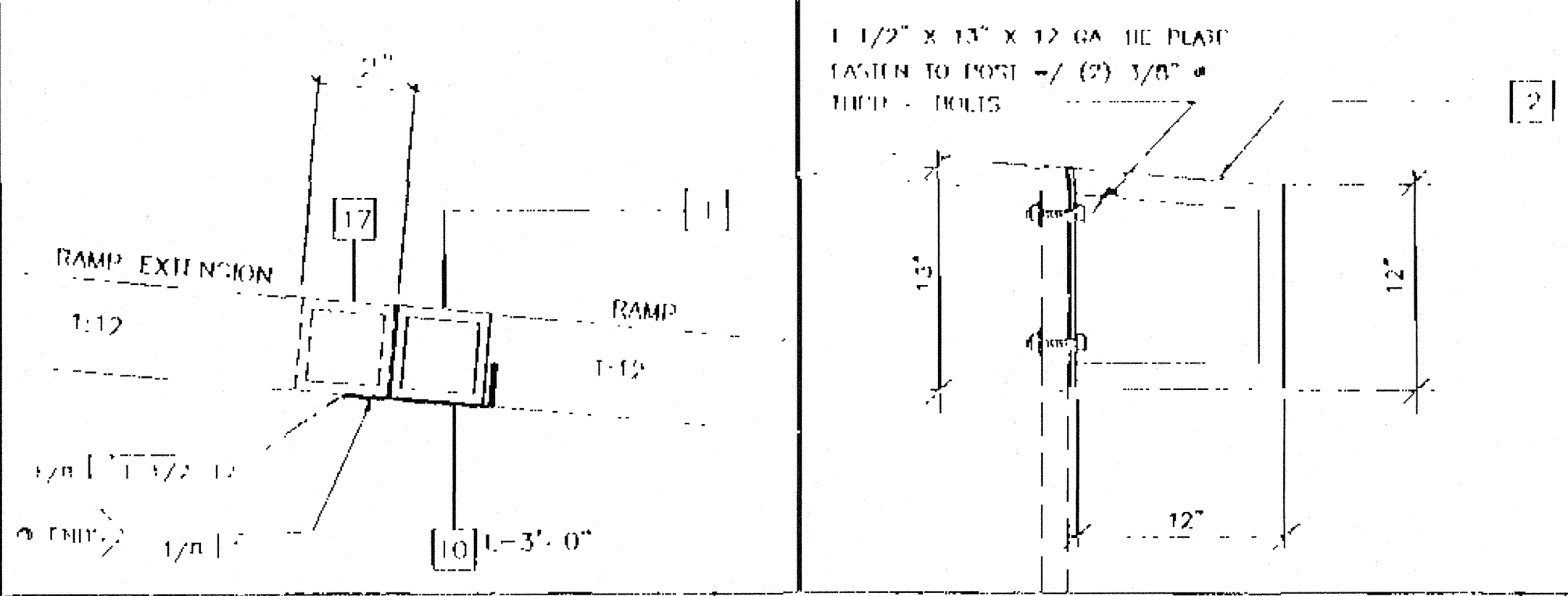
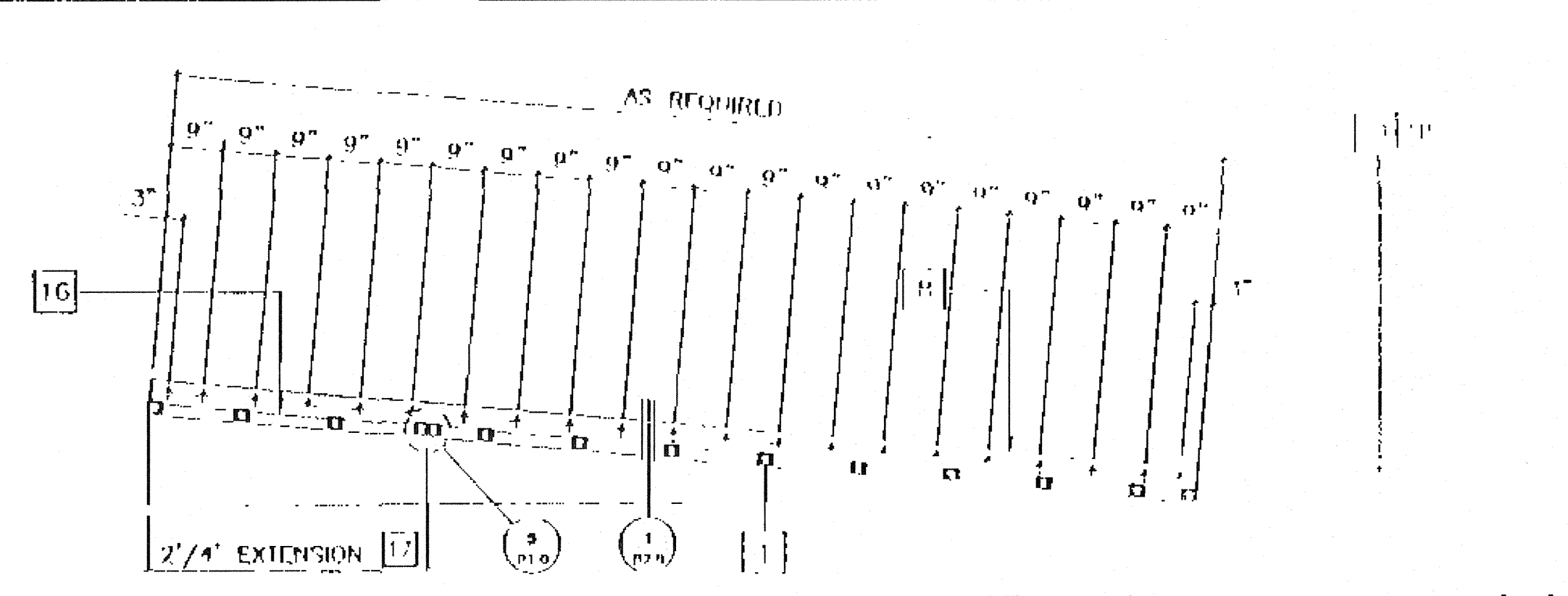
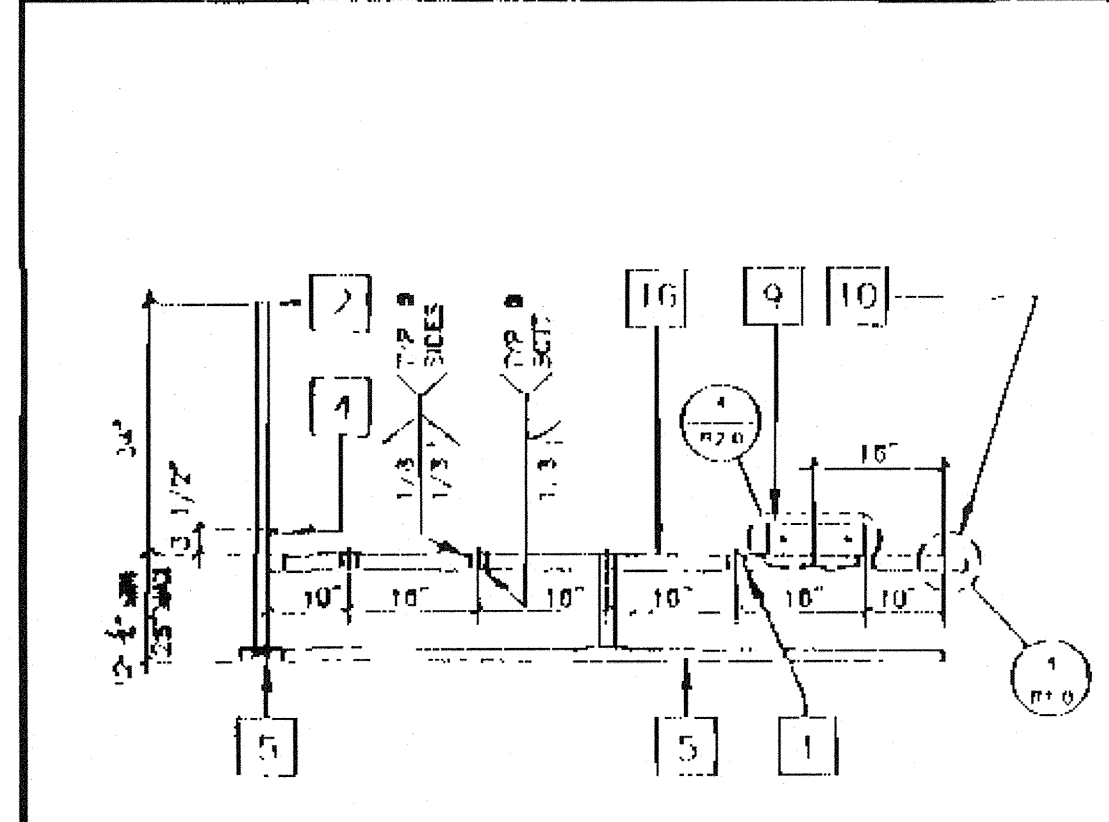

LONG. SECTION @ LANDING 14

LONGITUDINAL SECTION @ RAMP 9

RAMP EXTENSION TO RAMP 5

GUARD RAIL EXTENSION 3

- NOTES**
- 1 RAMP: RAMP SHALL NOT SLOPE MORE THAN 1" IN 12"
  - 2 HANDRAILS: HANDRAILS AT BOTH SIDES OF RAMP AT 34" HT.
  - 3 SURFACE: LANDING & RAMP TO HAVE NON-SLIP SURFACE. AMCOR GRIP II AS MANUFACTURED BY AMERICAN CHEMICAL COMPANY (OR EQUAL)
  - 4 GROUNDING: PROVIDE GROUNDING OF RAMP TO IRON FRAME W/ #10 CU TO BOTH GROUND LUGS.
  - 5 ARCHITECT SITE / RAMP / LANDING PLANNING: DUE TO VARYING SITE CONDITIONS THE MAXIMUM HEIGHT OF FINISH FLOOR FROM GRADE IS 28". THEREFORE IT IS POSSIBLE THAT THE ACCESS RAMP ATTACHED TO THE BUILDING COULD BE 20'-0" AT A SLOPE OF 1:12 ARCHITECT MUST TAKE INTO ACCOUNT THAT THE RAMP SUPPLIED BY MODTECH INC. IS 11'-0" AT A SLOPE OF 1:12 THEREFORE THE ARCHITECT WILL HAVE TO DESIGN AND PROVIDE SUFFICIENT DETAILS OF RAMP EXTENSIONS AND BOTTOM LANDING DEPENDING ON PARTICULAR SITE CONDITIONS. IN NO WAY IS MODTECH INC. RESPONSIBLE FOR ANY RAMP EXTENSION EXCEEDING THE ORIGINAL PLAN AS SHOWN ON SHEET R-1.
  - 6 ALL 1 1/4" AND 1 1/2" TUBE SIZES TO BE OF ASTM A500 GRADE A STEEL (Fy = 39 KSI)

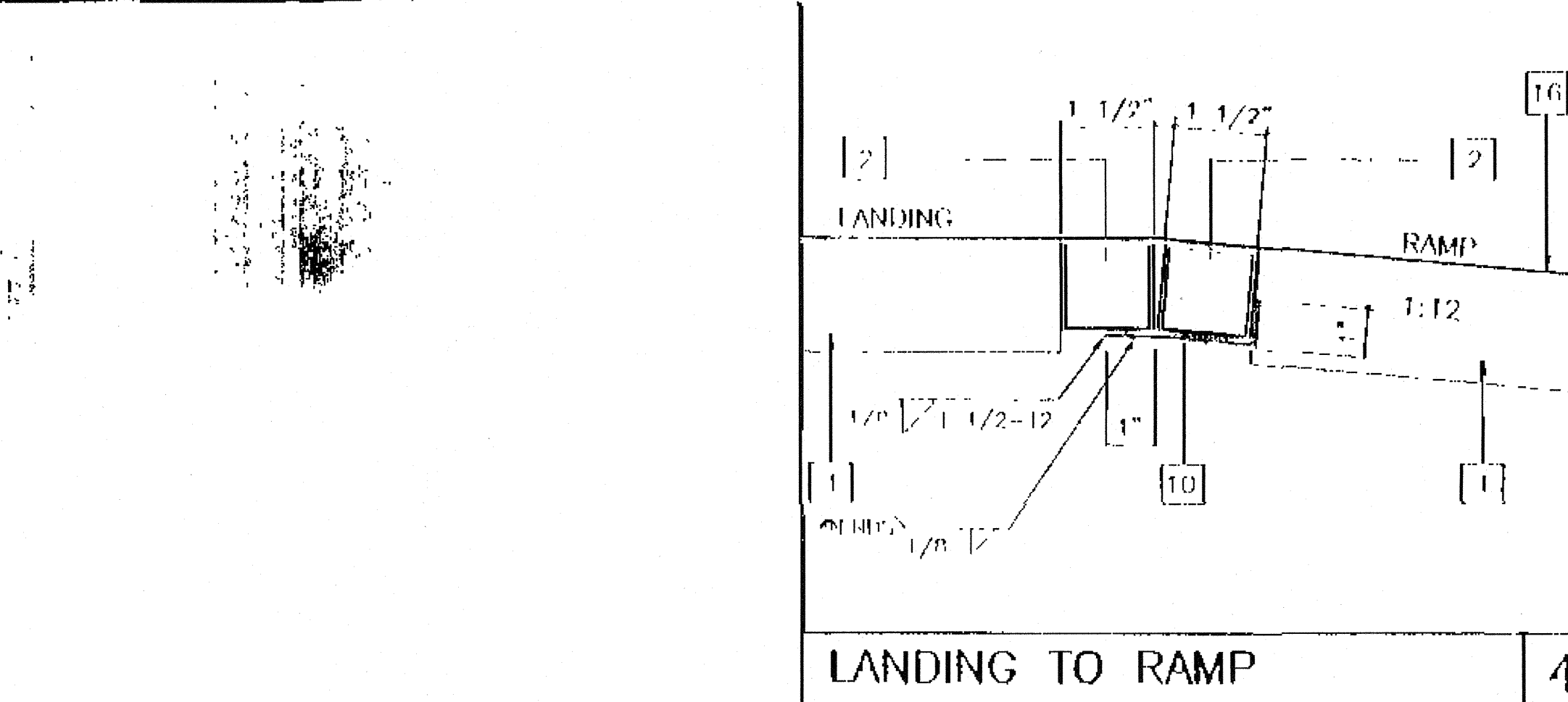
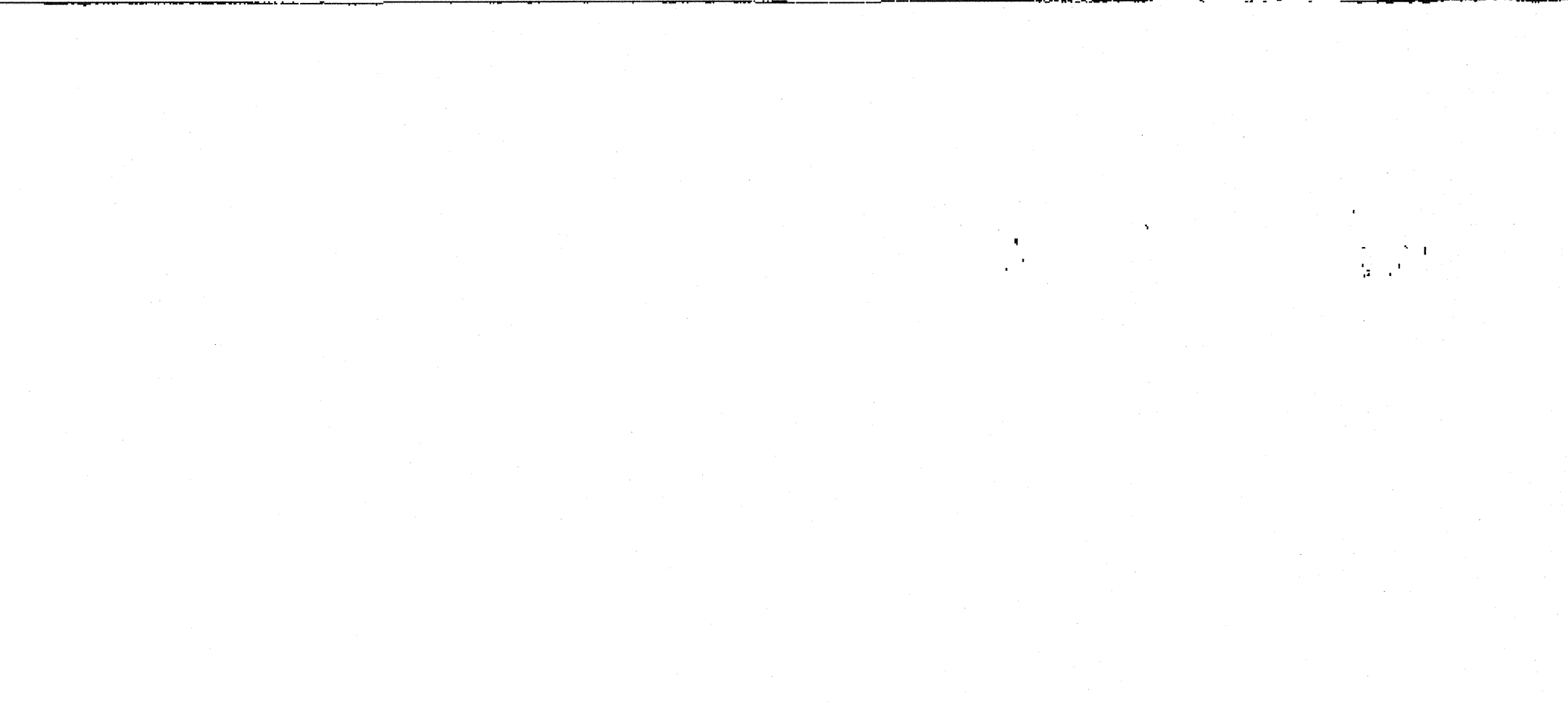
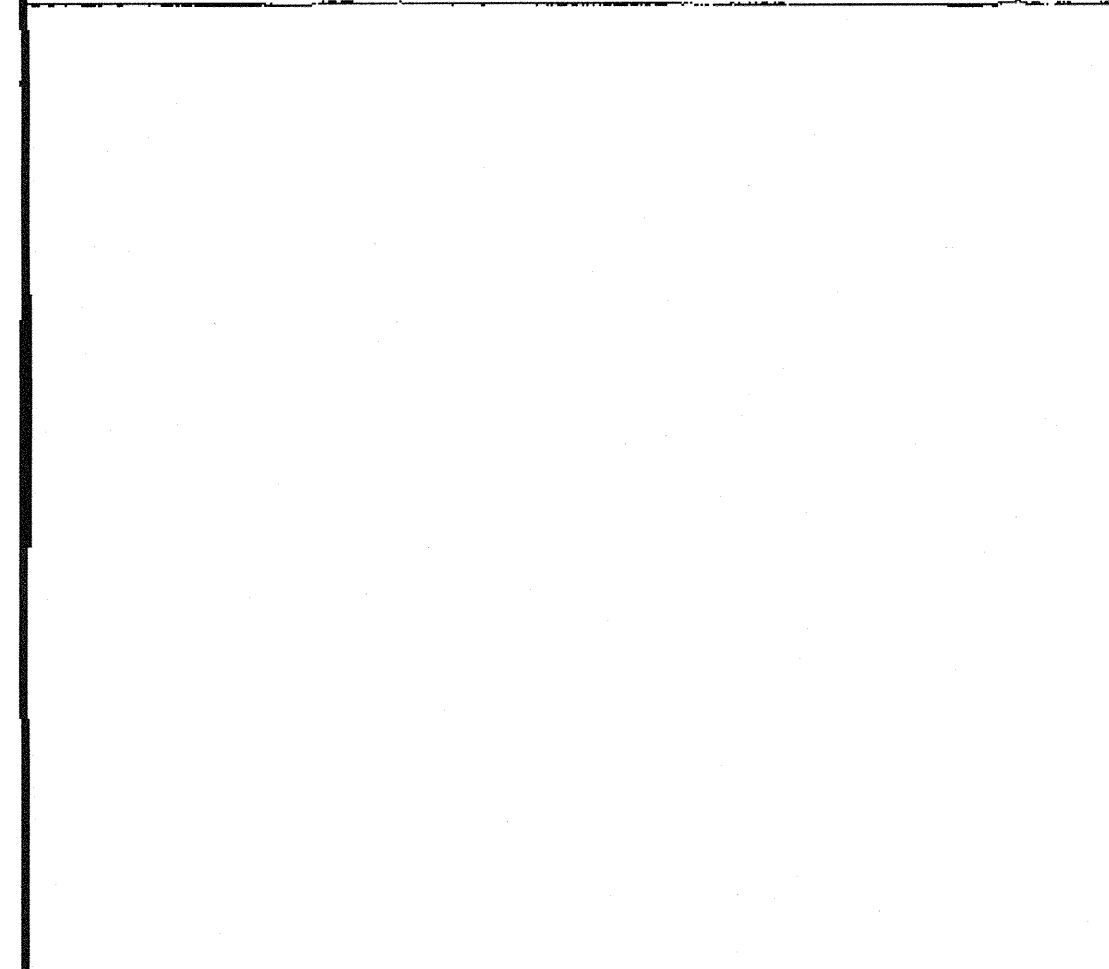

LANDING TO RAMP 4

**REVISIONS**



Electrical Engineer's Seal

Mechanical Engineer's Seal

Structural Engineer's Seal

Architect's Seal

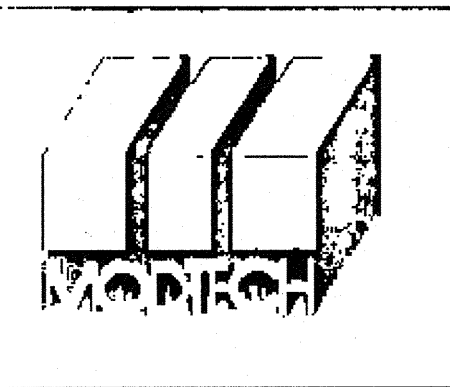
PC 275  
REVISED



**MODTECH INC.**  
2030 BARRETT AVENUE  
PERRIS, CALIF. 92572  
PH (909) 943-4014  
FAX (909) 940-0472

Job Number: PC 275

© MODTECH INC. 1997  
DIV OF THE STATE ARCHITECT  
APPROX 110000  
AC PL SS TB  
DATE 7/24/14

drawn by: LVI  
date: 11/98  
checked by:  
project manager:  
MODTECH logo no. **R1.0**

**RAMP / LANDING**

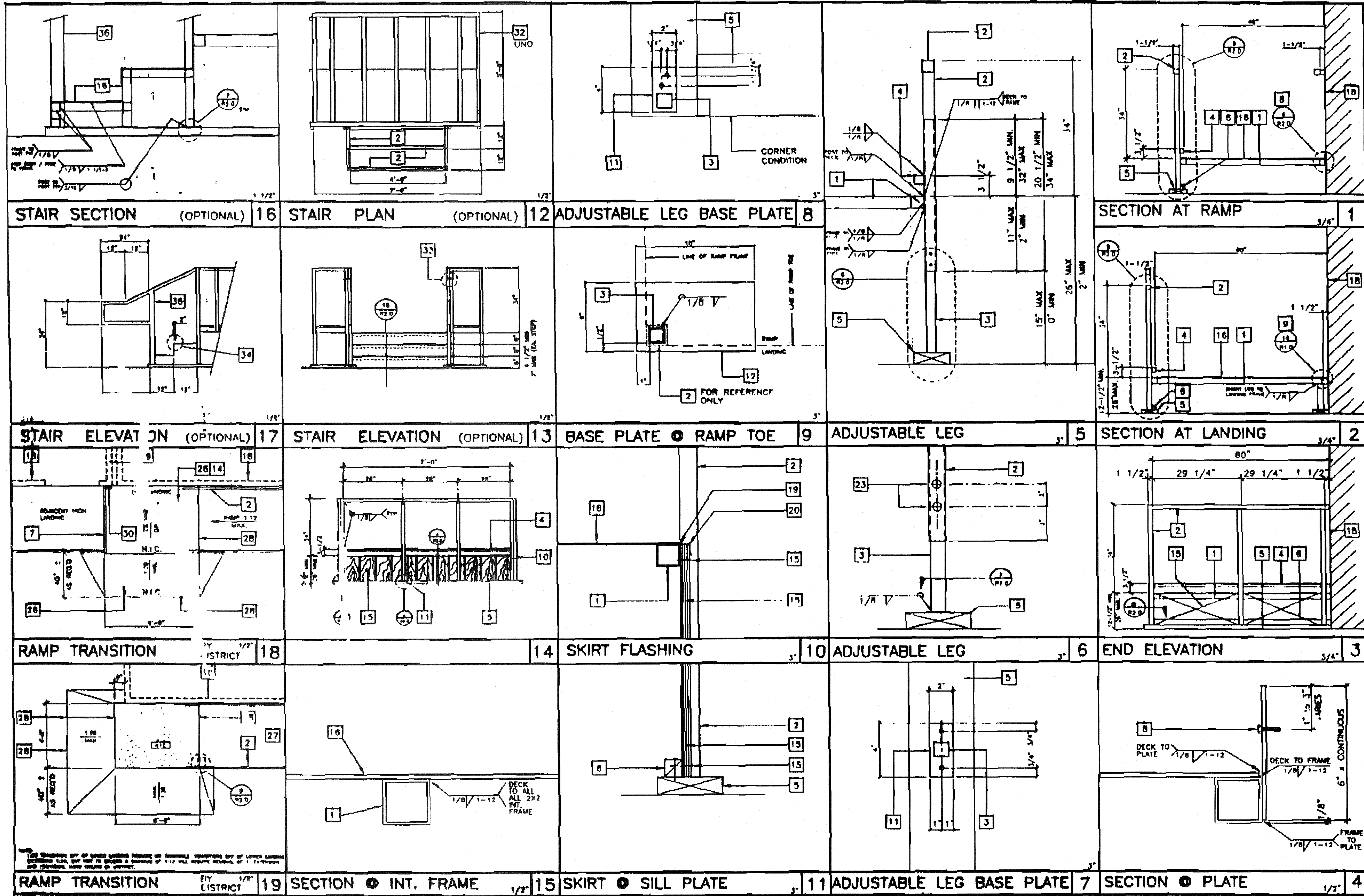

- ### KEY NOTES
- TS 2" x 2" x 14ga
  - TS 1 1/2" x 1 1/2" x 14ga (Ty = 38 KSI)
  - TS 1 1/4" x 1 1/4" x 14ga (Ty = 38 KSI)
  - TS 1" x 1" x 16ga WHITEZINC GUARD
  - 2 x 8 PT SILL PLATE
  - 2 x 2 HAULER W/16d @ 12" OC
  - 2 x 4 HW HEADER BY DISTRICT
  - 6" x 10ga CONTINUOUS PLATE W/ #14 @ 2" TEK SCREWS @ 8" OC INTO WOOD OR FOUNDATION BLOCKS OR #14 @ 2" TEK SCREWS INTO METAL W 8" OC
  - 2" x 4" x 12ga BASE PLATE W/2-1/4" x 1" LAGS
  - 6" x 10" x 12ga BASE PLATE @ RAMP TOE
  - LOWER LANDING BY DISTRICT
  - SHORING: PLYWOOD TO MATCH BUILDING SIDING, PLACE ALL EDGES AT LEAST W/2" @ 8" OC EDGES AND 1" @ 8" FIELD. AT EDGE CONNECTION TO F.S. USE #14 x 2" TEK SCREWS @ 9" OC
  - 12ga METAL DECK: NON-SLIP SURFACE. DESIGN COEFFICIENT OF FRICTION GREATER THAN EX. MAINTAINABLE FOR 1 YR EXISTING BUILDING.
  - CAULKING
  - 28 ga FLASHING
  - 3/8" dia x 2" LONG HD W/NUT & WASHERS
  - RAVE BY DISTRICT
  - RAMP BY MODTECH
  - FLUSH TRANSITION
  - 3" MINIMUM BUILDING GENERATION
  - PROVIDE DRAINAGE FOR WATER FROM DOWNSPOUT FOR THIS CONNECTION. BY DISTRICT
  - FOR LANDING DETAILS AND RAMP ATTACHMENT SEE 12/RT.3
  - PASTEN POSTS W/ 3/8" x THRU BOLT. TYPICAL
  - 6" MINIMUM STRIPS MAX 1" FROM EVERY STAIR nosing. USE CONTRASTING COLOR
  - TS 2 1/2" x 1 1/2" x 8ga ASTM A500 GRADE A

NO.	REVISIONS

Vertical Engineer's Seal  
Mechanical Engineer's Seal  
Structural Engineer's Seal  
Architect's Seal

IDENTIFICATION STAMP  
DIV. OF THE STATE ARCHITECT  
OFFICE OF REGULATION SERVICES

PC 275

JAN 21 1997  
REVISED

**MODTECH INC.**  
2830 BARRETT AVENUE  
PERRIS, CALIF. 92572  
PH (909) 943-4014  
FAX (909) 940-0427

Job Number: PC 275

© MODTECH, INC. 1997

drawn by: [Signature]  
checked by: [Signature]  
approved by: [Signature]

7/21/94

# RAMP/STAIR DETAILS R2.0

JOB # 3405

MODTECH DESIGN MT-2440

PC 04-101419

RELOCATABLE CLASSROOM BUILDINGS  
BUILDING SIZE: 24'x40'

FOR

WILLIAMS SCOTSMAN

(56) BUILDINGS

STOCKPILE

BUILDING DATA

STRUCTURAL DESIGN: RIGID FRAME  
TYPE OF CONSTRUCTION: V-N  
WIND LOAD (EXP C): 80 MPH  
FLOOR LIVE LOAD: 50 PSF  
ROOF LIVE LOAD: 20 PSF  
OCCUPANCY: 24'x40' CLASSROOM: E-2

BUILDING AREA:  
24'x40' BUILDING - 960 SF

APPLICABLE CODES

- TITLE 24, CCR, PART 2, 1998 CBC (97 UBC W/98 CA AMENDMENTS)
- 1997 UBC & 1998 CA AMENDMENTS (98 CBC - PART 2, TITLE 24, CCR)
- 1998 NEC & 1998 CA AMENDMENTS (98 CEC - PART 3, TITLE 24, CCR)
- 1997 UMC & 1998 CA AMENDMENTS (98 CMC - PART 4, TITLE 24, CCR)
- 1997 UPC & 1998 CA AMENDMENTS (98 CPC - PART 5 TITLE 24, CCR)
- 1997 UFC & 1998 CA AMENDMENTS (98 CFC - PART 9, TITLE 24, CCR)
- 1998 CA BUILDING STANDARDS CODE
- TITLE 19, CCR, PUBLIC SAFETY, STATE FIRE MARSHAL REGULATIONS.

LEGEND

SYMBOL	DESCRIPTION
	DETAIL (1) ON SAME SHEET AS SYMBOL
	DETAIL (1) ON SHEET (2)
	KEY NOTE (1) ON SAME SHEET AS SYMBOL
	SECTION "A" ON SHEET (2)
	REVISION/CHANGE IN DRAWING. (1) IS FIRST REVISION
	HIGHLIGHTS CHANGED AREA
	DOOR REFERENCE
	WINDOW REFERENCE
	ELECTRICAL ITEM(S) SEE ELECTRICAL DRAWINGS
	HEATING/VENTILATING & AIR CONDITIONING ITEM(S) SEE MECHANICAL DRAWINGS
	PLUMBING ITEM(S) SEE MECHANICAL DRAWINGS
	STRUCTURAL ITEM(S) SEE STRUCTURAL DRAWINGS
	FINISH ITEM(S) SEE FINISH SCHEDULE
	RAMP - SEE RAMP DRAWINGS

ABBREVIATIONS

- AGC = ABOVE GRADE CONCRETE
- BGC = BELOW GRADE CONCRETE
- DIA = DIAMETER
- CLR = CLEAR
- GA = GAUGE
- SIM = SIMILAR
- MAX = MAXIMUM
- MIN = MINIMUM
- NIC = NOT IN CONTRACT
- NTS = NOT TO SCALE
- OC = ON CENTER
- OD = OUTSIDE DIAMETER
- OSB = ORIENTED STRAND BOARD
- ROH = ROOF OVERHANG
- SIM = SIMILAR
- STS = SELF TAPPING SCREW
- STSMS = SELF TAPPING SHEET METAL SCREW
- TYP = TYPICAL
- UON = UNLESS OTHERWISE NOTED

WITH THE SIGNING OF THESE DRAWINGS, WE ACKNOWLEDGE THAT WE HAVE REVIEWED THESE PLANS AND SPECIFICATIONS AND HAVE FOUND THEM TO BE IN GENERAL COMPLIANCE WITH THE BID DRAWINGS, SPECIFICATIONS AND ASSOCIATED ADDENDA. WHEN THESE PLANS AND SPECIFICATIONS HAVE BEEN APPROVED BY THE DIVISION OF THE STATE ARCHITECT, THEY SHALL PRESIDE OVER CONFLICTING AREAS IN THE BID DRAWINGS AND SPECIFICATIONS, AND ANY ADDENDA THERETO.

CONFIDENTIAL - THIS DOCUMENT AND THE INFORMATION CONTAINED HEREIN ARE THE PROPERTY OF MODTECH, INC. UNAUTHORIZED COPYING, DISCLOSURE OR OTHER UNAUTHORIZED USES ARE PROHIBITED.

SHEET INDEX

ARCHITECTURAL	
A.0	TITLE SHEET
A1.0	FLOOR PLAN 24'x40'
A2.0	ROOF PLAN (DUAL PITCH) 24'x40'
A3.0	EXTERIOR ELEVATIONS (DUAL PITCH) 24'x40' W/ FASCIA
A4.0	INTERIOR ELEVATIONS 24'x40'
A5.0	WALL, WINDOW, DOOR, MIRROR, LINEN, SINK, TUB, SHOWER, CLOSET, STAIR, RAMP, ELEVATIONS
A6.0	WALL, WINDOW, DOOR, MIRROR, LINEN, SINK, TUB, SHOWER, CLOSET, STAIR, RAMP, DETAILS
A7.0	REFLECTED CEILING PLAN (24'x40') (10 LIGHTS)
A8.0	REFLECTED CEILING OF DETAIL

STRUCTURAL	
F1.0	FOUNDATION PLAN (24 x 40) :40 PSI LL (WOOD)
F2.0	FOUNDATION DETAILS (WOOD)
S1.0	FLOOR FRAMING PLAN (90 PSI LL)
S1.2	FLOOR FRAMING DETAILS (TYPICAL)
S2.0	ROOF FRAMING PLAN (DUAL PITCH) W/ FASCIA
S2.1	ROOF FRAMING DETAILS (TYPICAL)
S3.0	STRUCTURAL ELEVATIONS & DETAILS (DUAL PITCH)
S4.0	WALL FRAMING (WOOD)
S5.0	WALL FRAMING DETAILS (WOOD)
S6.0	WALL FRAMING DETAILS (MASONRY)

MECHANICAL	
M1.0	MECHANICAL (HVAC) PLAN 24'x40' 3 1/2 TONS

ELECTRICAL	
E1.0	ELECTRICAL PLAN 24'x40'

RAMP	
R1.00	RAMP/LANDING PLAN W/ 11' RAMP
R1.02	RAMP/STAIRS DETAILS

IDENTIFICATION STAMP  
DIV. OF THE STATE ARCHITECT  
OFFICE OF REGULATION SERVICES

04 10 1998  
AC: C. ELS. F. SSG  
DATE: MAR 8 2007

PLS: EPPEN D  
RCP: G. JONES  
SSI: CP W/TA

APPROX 115000

AC: AW FLS SSG  
DATE: 7/24/14

JBB N64 3405

CBC 1997 PC

REVISIONS	Electrical Engineer's Seal	Mechanical Engineer's Seal	Architect's Seal

Architect's Seal

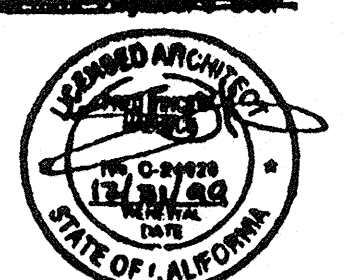

Architect's Seal

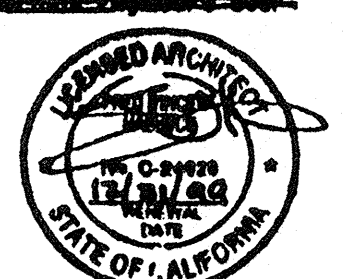

IDENTIFICATION STAMP  
DIV. OF THE STATE ARCHITECT  
OFFICE OF REGULATION SERVICES

PC-04  
101419

AC: D. FLS SSG  
DATE: JAN 12 2006  
RCP: D. PENNINGTON  
PRO: EPPEN D

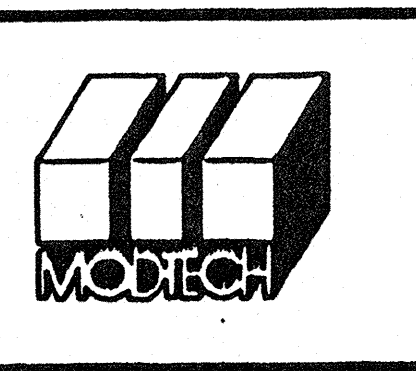

**MODTECH INC.**  
2830 BARRETT AVENUE  
PERRIS, CALIF. 92572  
PH (909) 943-4014  
FAX (909) 940-0427

PROJECT NUMBER: 3405  
© MODTECH, INC. 1999

DRAWN BY: [Signature]  
DATE: 10/22/99  
CHECKED BY: [Signature]  
DATE: 10/22/99  
MODTECH Index No. [Signature]  
**A.0**

COVER SHEET

3405

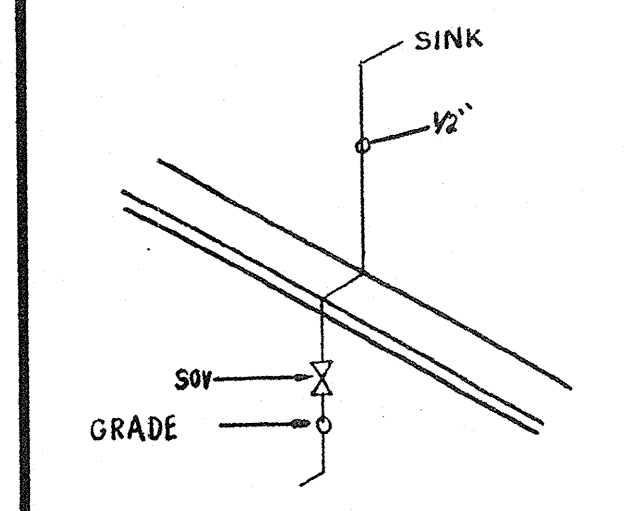
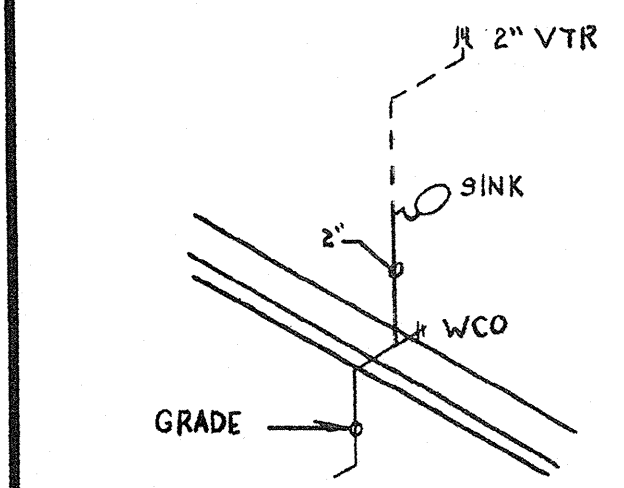
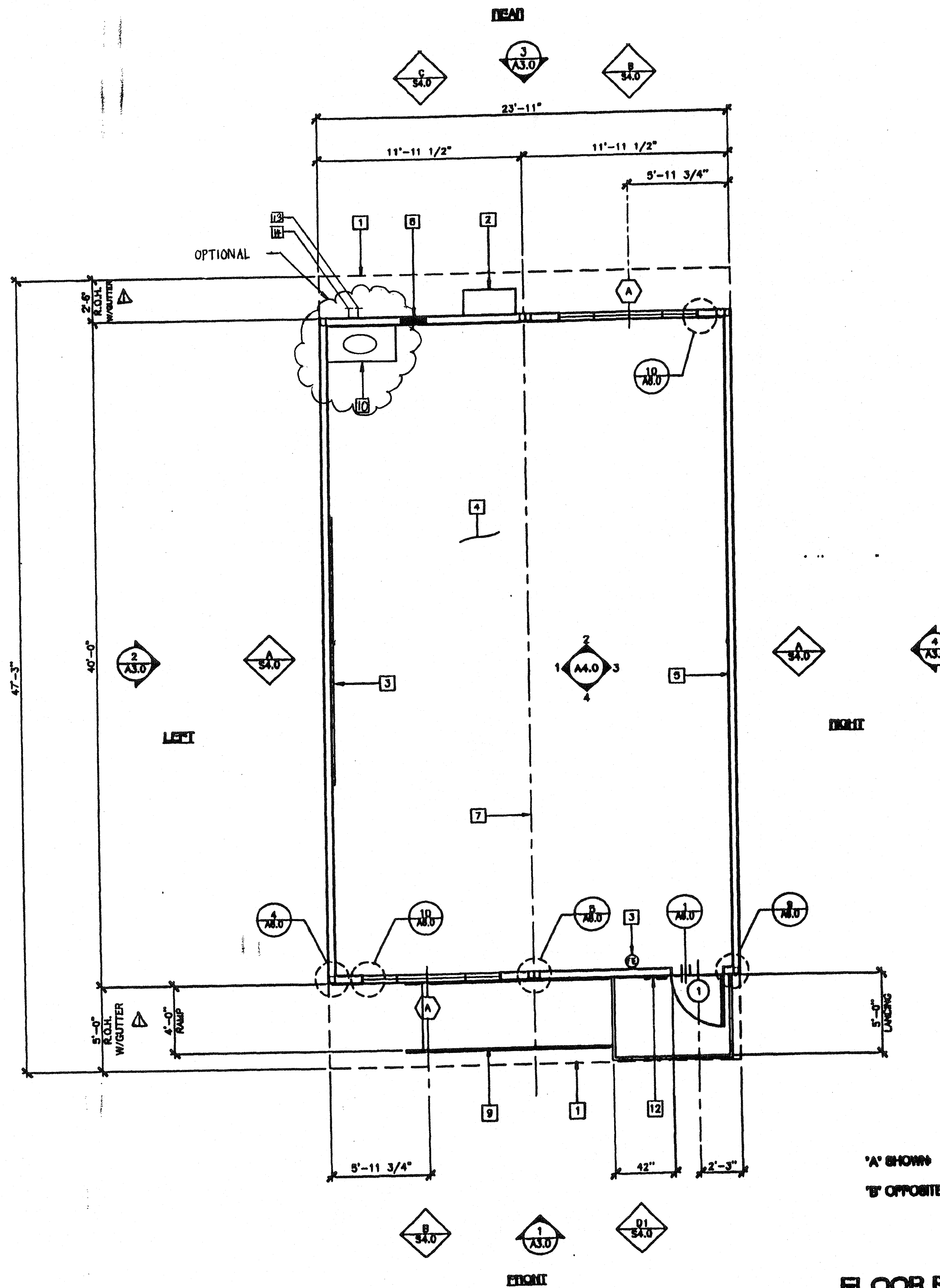

**KEY NOTES**

- 1 ROOF OVERHANG
- 2 HVAC UNIT (HV)
- 3 2 - 8'x4' MARKER BOARDS (SEE SPEC'S FOR TYPE)
- 4 FINISH FLOORING (FIN)
- 5 INTERIOR FINISH (FIN)
- 6 FIRE EXTINGUISHER - 5 LBS DRY CHEMICAL WITH 2A-10BC UL RATING WALL MOUNTED BRACKET, HANDLE AT 48" AFF
- 7 MODLINE (M)
- 8 ELECTRICAL PANEL
- 9 RAMP/LANDING (RMP)
- 10 SINK CABINET OPTIONAL LAV: KOHLER # K-2867 FAUCET CHICAGO 833-669
- 11 NOT USED
- 12 SIGNAGE PROVIDED AND INSTALLED BY DISTRICT PRIOR TO OCCUPANCY, SEE A.S.O.
- 13 COLD WATER SUPPLY
- 14 WASTE AND VENT P.O.C.

**NOTES**

- 1. METAL TAG ON ALL MODULES, MECHANICALLY ATTACHED TO REAR EXTERIOR OF BUILDING SHOW D.S.A. APPLICATION NUMBER, MANUFACTURER'S NAME AND SERIAL NUMBER.
- 2. METAL TAG MIN. 3 1/2"X1 1/2" METAL I.D. W/  
1. DESIGN WIND LOAD  
2. DESIGN ROOF LOAD
- 3. PROVIDE MIN. 3 1/2"X1 1/2" METAL TAG INSTALLED INSIDE THE ELECTRICAL PANEL SHOWING OPSC NUMBER AND DSA NUMBER.

IDENTIFICATION STAMP  
DIV. OF THE STATE ARCHITECT  
OFFICE OF REGULATION SERVICES  
04 01984  
AC 6 FLS SS TB  
DATE MAR 08 2000

IDENTIFICATION STAMP  
DIV. OF THE STATE ARCHITECT  
APPROX 115000  
AC 11 FLS SS TB  
DATE 1/22/14

**FLOOR PLAN** 24x40  
SCALE: 1/4" = 1'-0"

PC  
CBC 1998

**REVISIONS**

1	CLARIFY OVERHANGS	SS
2		
3		
4		

Electrical Engineer's Seal  
Mechanical Engineer's Seal  
Architect's Seal

SEVERN COUNTY DEPT. OF THE STATE ARCHITECT OFFICE OF REGULATION SERVICES  
PC-04  
10149  
DATE 06/23/12

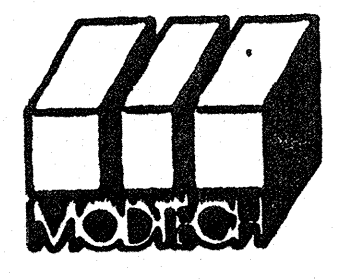

**MODTECH INC.**  
2830 BARRETT AVENUE  
PERRIS, CALIF. 92572  
PH (909) 943-4014  
FAX (909) 940-0427

PROJECT NUMBER: © MODTECH, INC. 1999

DRAWN BY:  
DATE:  
CHECKED BY: SS  
DATE: 10/22/14

**FLOOR PLAN** A1.0

FILE PATH: 2440-0-A1-01.DWG PROJECT NO. 3405 PC-04-101419



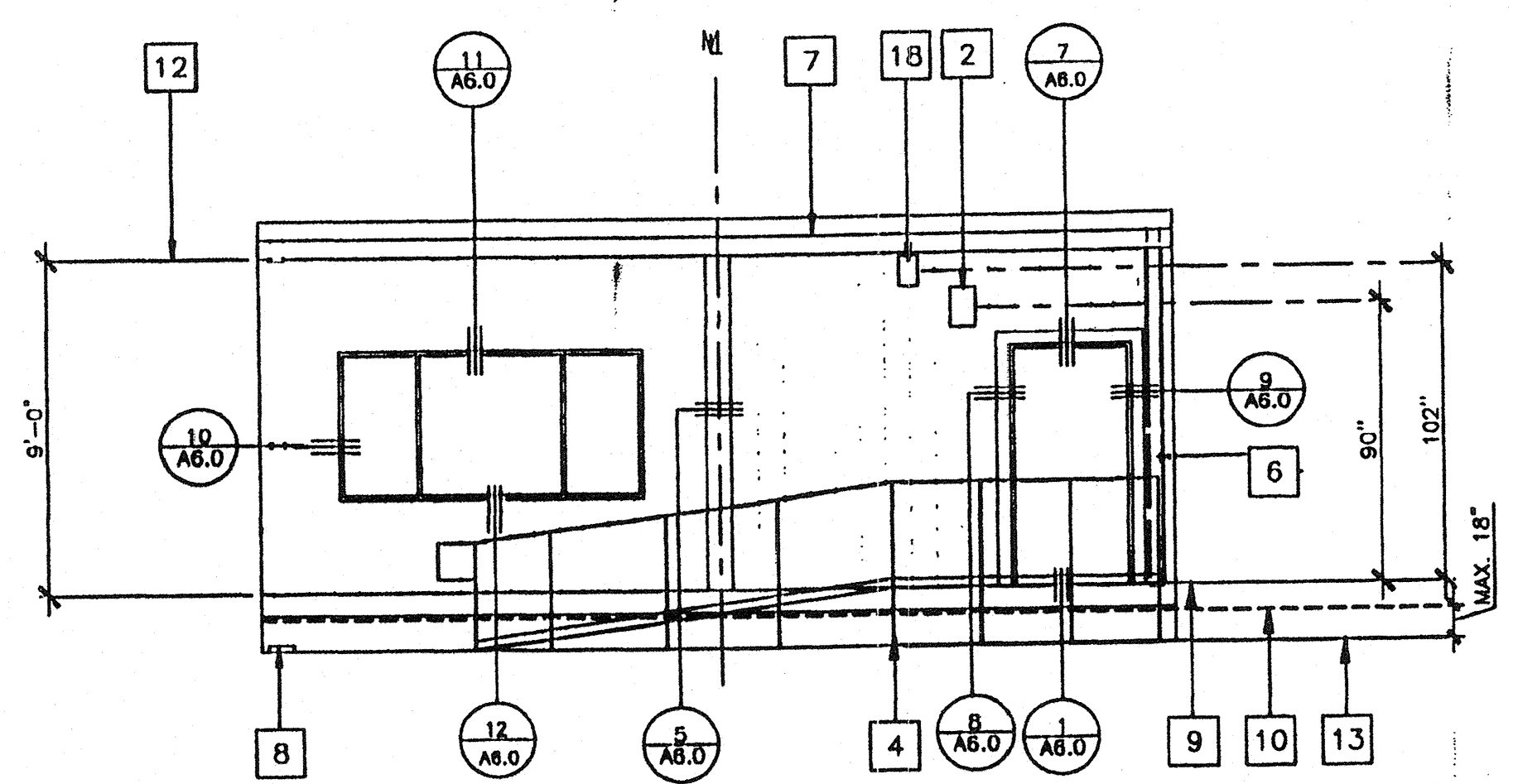

1 FRONT ELEVATION  
1/4" = 1'-0"

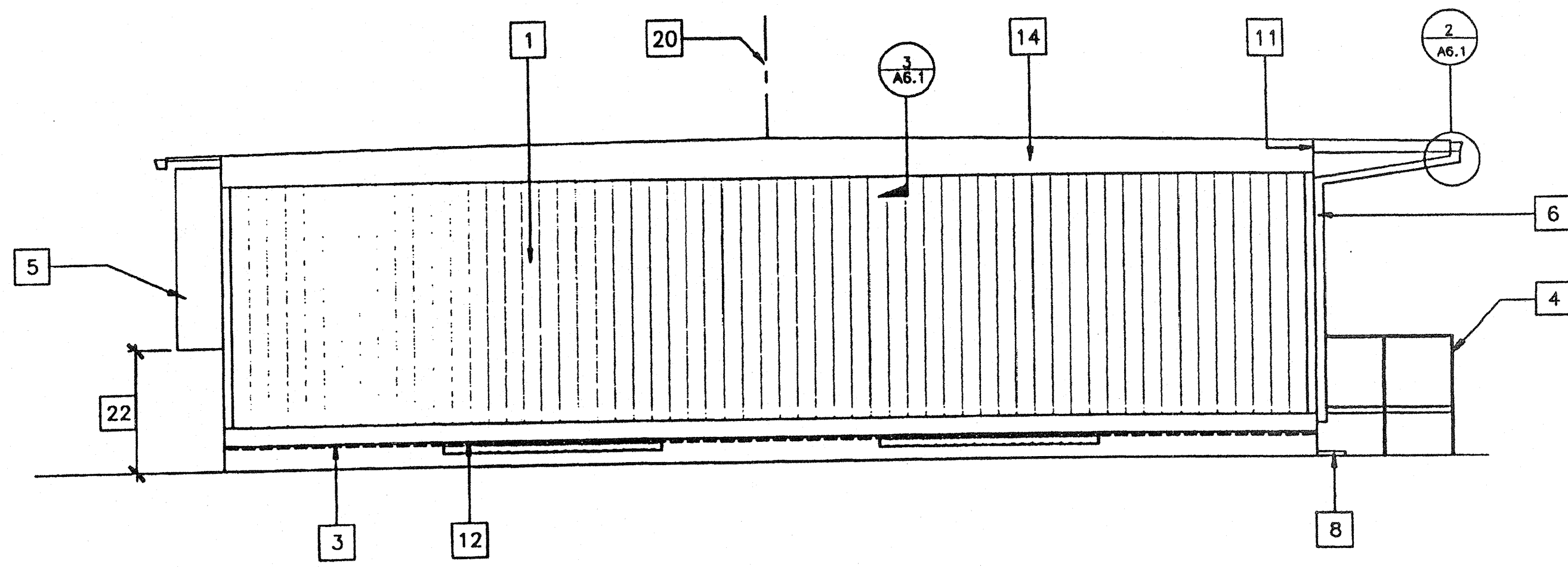

2 LEFT ELEVATION  
1/4" = 1'-0"

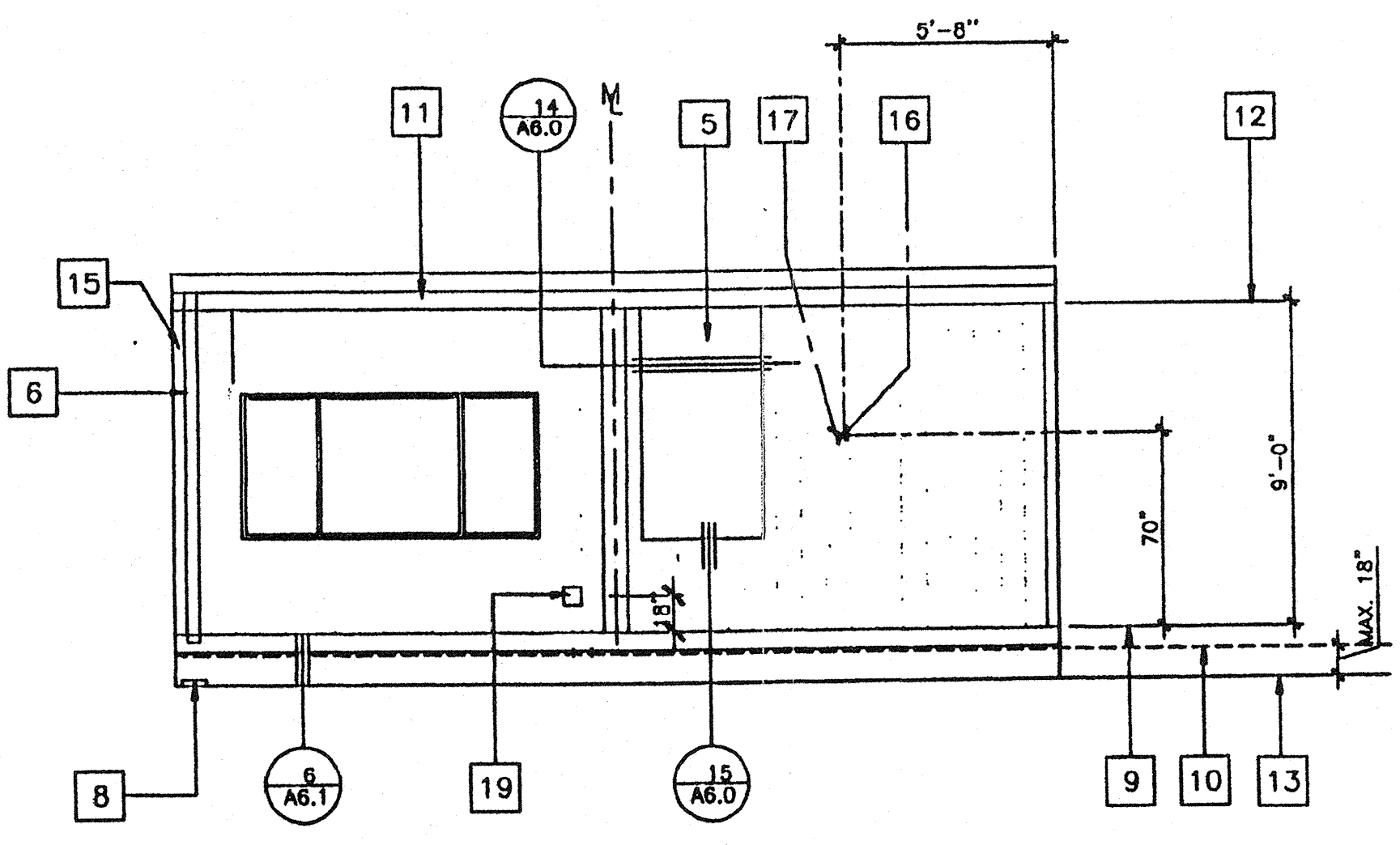

3 REAR ELEVATION  
1/4" = 1'-0"

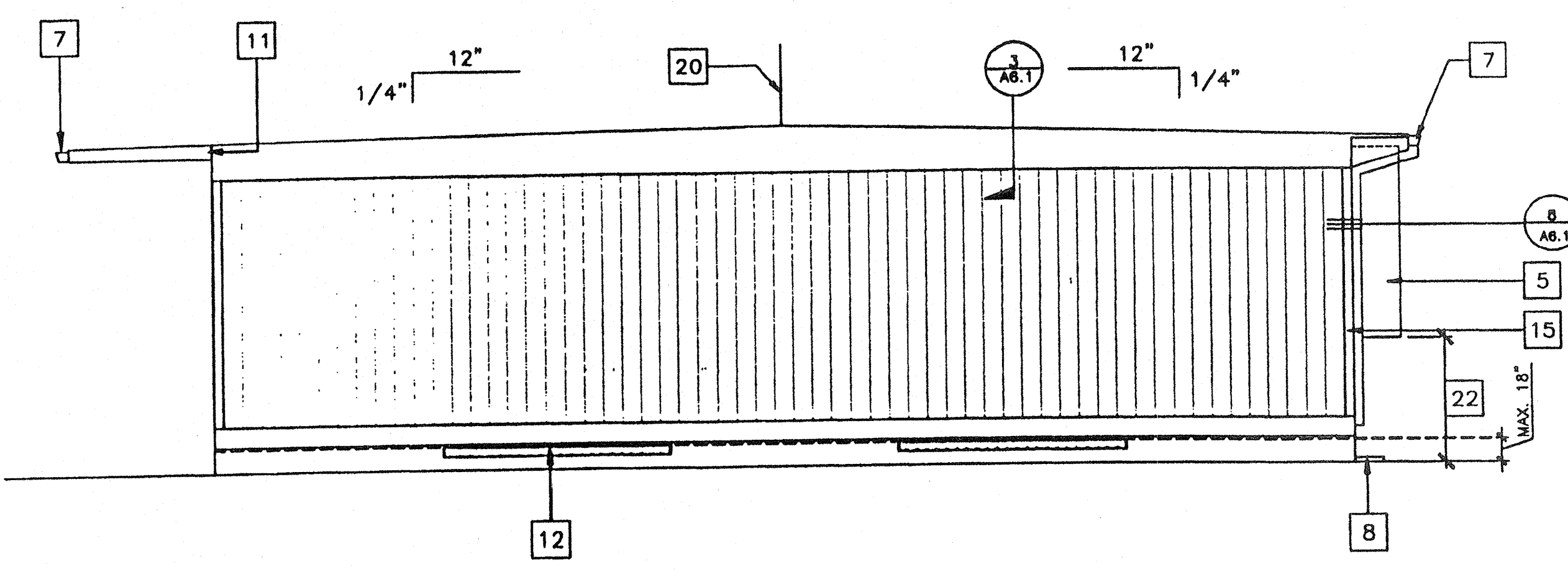

4 RIGHT ELEVATION  
1/4" = 1'-0"

"A" = SHOWN  
"B" = OPPOSITE

KEY NOTES

- 1 TYPICAL EXTERIOR SIDING (SEE A5.0)
- 2 EXTERIOR LIGHT FIXTURE (SEE SPEC'S)
- 3 TOP OF SKIRTING
- 4 RAMP AND LANDING SEE SHT. R-1
- 5 HVAC UNIT. SEE (HV)
- 6 DOWNSPOUT (TYP.) FOR (2). FASTEN TO BLD'G. TYP 3 PLACES (SEE 8/A6.1)
- 7 CONTINUOUS GUTTER WITH DOWNSPOUT (LOCATION OF DOWNSPOUT SHOWN ON ROOF PLAN) SEE A2.0
- 8 SPLASH BLOCK (BY OTHERS)
- 9 FINISH FLOOR LINE
- 10 BOTTOM FLANGE OF FLOOR BEAM
- 11 ROOF HEADER
- 12 VENT. SEE FOUNDATION PLAN
- 13 FINISH GRADE
- 14 ROOF BEAM SEE (STR)
- 15 COLUMN SEE (STR)
- 16 ELECTRICAL STUB-OUT SEE (EL)
- 17 GROUND STUB-OUT SEE (EL)
- 18 J BOX FOR EXT. FA HORN SEE (EL)
- 19 NEMA 6" X 6" GUTTER BOX SEE (EL)
- 20 RIDGE
- 21 NOT USED
- 22 IF HVAC UNIT IS LOCATED IN ANY PATH OF TRAVEL OR CIRCULATION AREA AND HEIGHT FROM GRADE TO BOTTOM OF UNIT EXCEEDS 27" THEN PROTECTION MUST BE PROVIDED.

NOTES

- 1. SEE FOUNDATION PLAN FOR SIZE AND LOCATION OF UNDER FLOOR VENTS.

IDENTIFICATION STAMP  
DIV. OF THE STATE ARCHITECT  
OFFICE OF REGULATION SERVICES  
04 01984  
AC 6 FLS SS  
DATE MAR 09 2009

IDENTIFICATION STAMP  
DIV. OF THE STATE ARCHITECT  
APPROX 115800  
AC 11 FLS SS  
DATE 7/24/14

CBC 1998 PC

REVISIONS	Electrical Engineer's Seal	Mechanical Engineer's Seal	Architect's Seal

Architect's Seal:

Architect's Seal:

IDENTIFICATION STAMP  
DIV. OF THE STATE ARCHITECT  
OFFICE OF REGULATION SERVICES  
PC-04  
101419  
AC 11 FLS SS  
DATE OCT 23 1995

**MODTECH INC.**  
2830 BARRETT AVENUE  
PERRIS, CALIF. 92572  
PH (909) 943-4014  
FAX (909) 940-0427

PROJECT NUMBER:

© MODTECH, INC. 1999

DRAWN BY:  
DATE:  
CHECKED BY: SS  
DATE: 10/22/99  
MODTECH Index No.  
**A3.0**

EXTERIOR ELEVATIONS

PROJECT NO. PC-04-101419

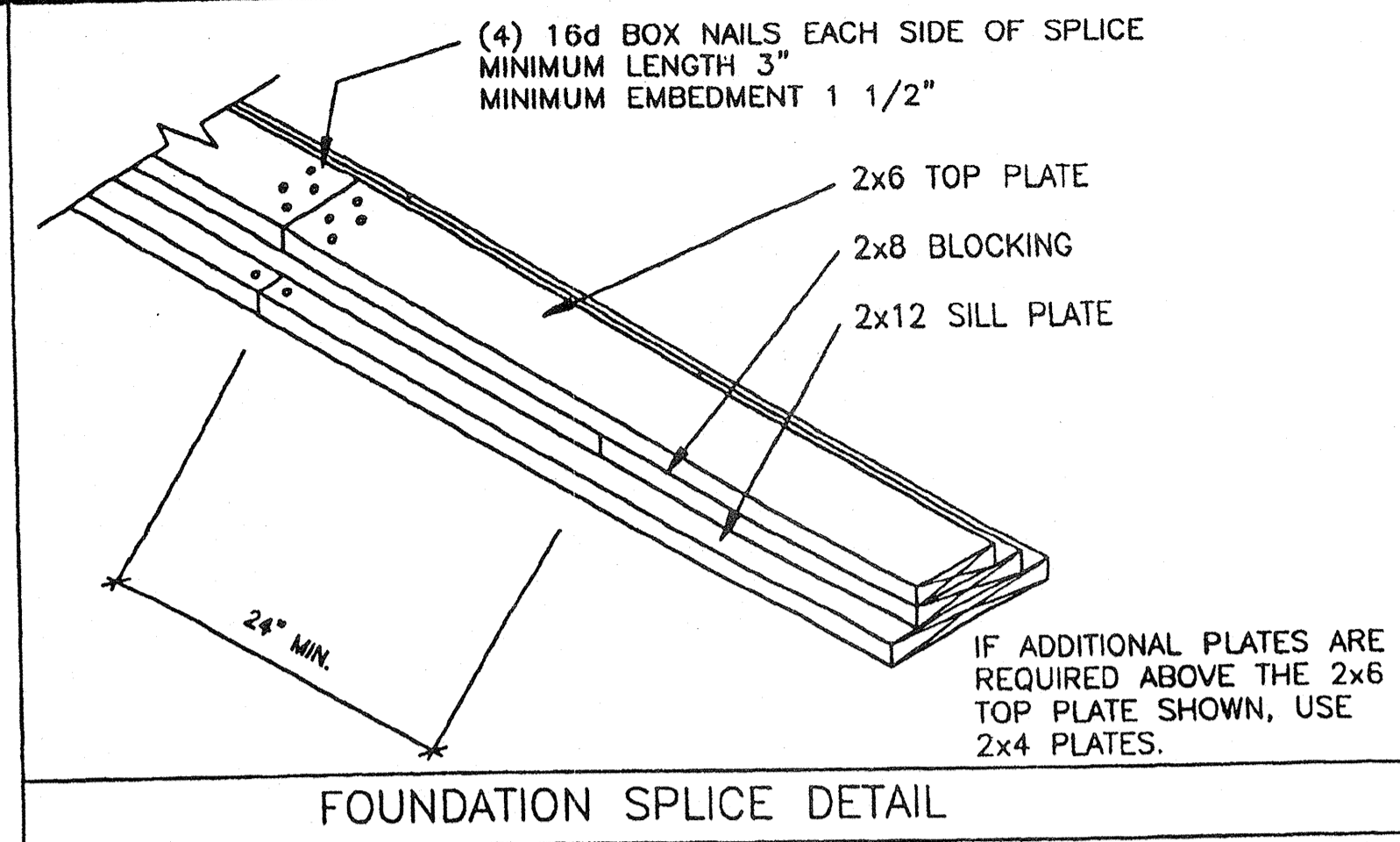
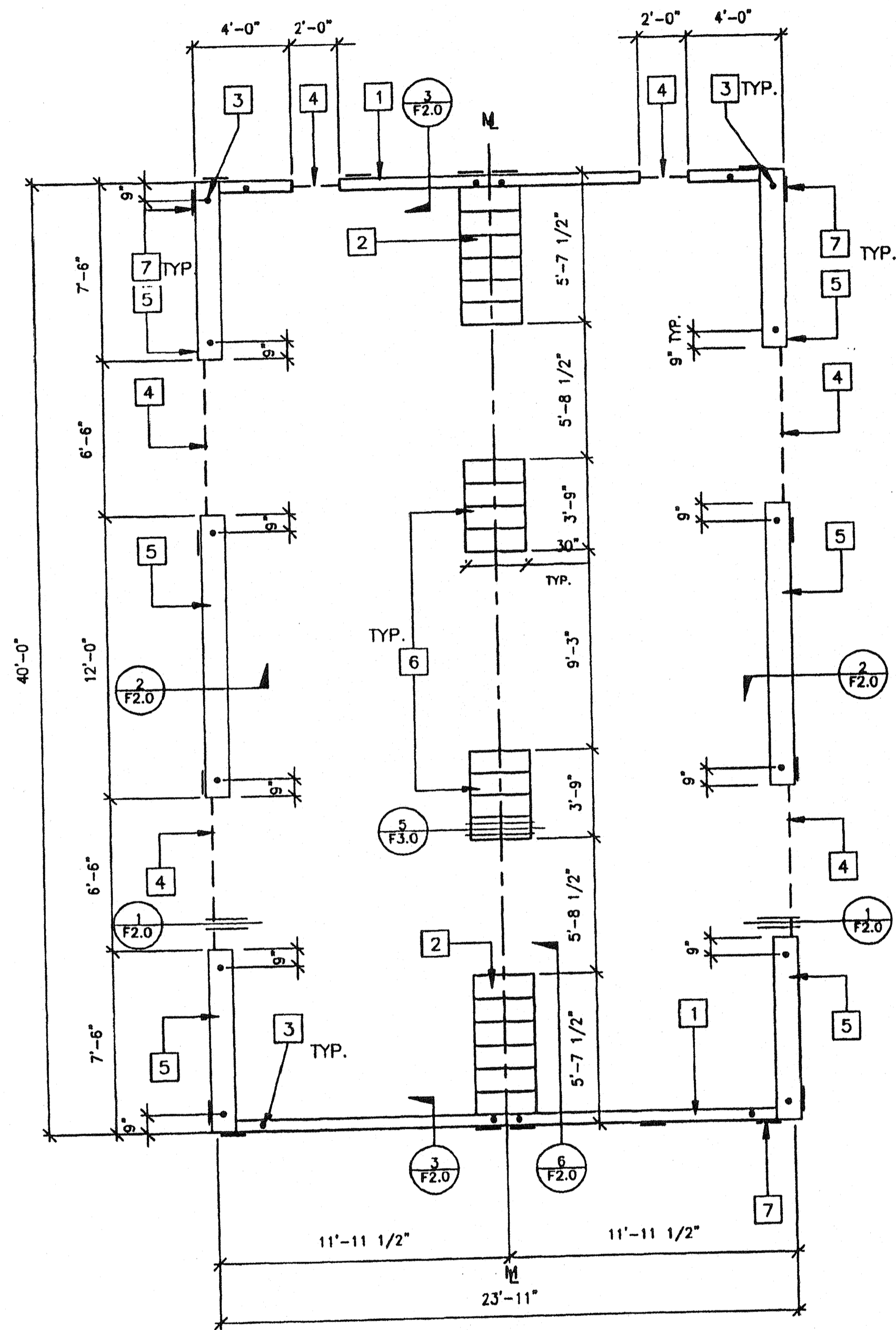

**KEY NOTES**

- 1 2"x6" SILL PLATE (END WALL)
- 2 6- 2X12X30" LONG SILL PADS
- 3 PIPE TO GRADE (TYP.)
- 4 3" HIGH BY 6'-6" LONG VENT @ SIDEWALLS  
3" HIGH BY 2'-0" LONG VENT @ ENDWALLS
- 5 2X12 SILL PLATE (SIDE WALL)
- 6 4-2X12X30" LONG SILL PADS
- 7 6"x12"x10 GA. PLATES  
5 @ ENDWALL, 4 @ SIDEWALL
- 8 NOT USED
- 9 NOT USED

**NOTES**

1. SILL RESTRAINT: ON A.C. PAVING AND ON SOIL 1" O.D. GALVANIZED PIPE AT 10'-0" 12" PENETRATION BELOW SURFACE VERTICALLY. DRILL SILL 1-1/4" MAX. PIPE MAY BE DRIVEN MAX. OF 45° ANGLE TO VERTICAL. (18-1/2" LONG PIPE REQUIRED FOR PENETRATION AT 45° ANGLE.)
  2. ON CONCRETE PAVING HILTI DS 82-P10 THRU SILL PLATE:  
END WALLS: 8" O.C.  
SIDE WALLS: 22" O.C.
  3. WHERE SHIM STOCK IS REQUIRED FOR LEVELING USE 1/4", 1/2", OR 3/4" THICK PLYWOOD SAME WIDTH AS BLOCK. P.T.
  4. VERIFY DRAINAGE TO PREVENT WATER FROM PONDING BENEATH THE STRUCTURE. WITH DISTRICT ARCHITECT SITE PLANS
  5. ALL FOUNDATION MATERIAL SHALL BE DOUGLAS FIR  
GROUND CONTACT: LP-22 (CCA .40)  
ABOVE GROUND: LP-2 (CCA .25)
  6. ALLOWABLE SOIL BEARING: 1000 P/SF
  7. "MACHINE APPLIED 16d FASTENERS SHALL HAVE AN EMBEDMENT OF NOT LESS THAN 1 1/2" INTO SECOND MEMBER, AND SHALL BE NOT LESS THAN 3" IN OVERALL LENGTH"
- THE ABOVE NAILS SHALL ALSO BE ACCEPTABLE FOR HAND NAILING, PROVIDED THE REQUIRED EMBEDMENT IS MAINTAINED.

**VENT CALCS.**

BLD'G SIZE 24' X 40' = 960  
 VENTILATION REQ'D 960 + 150 = 6.4SF  
 3"x6'-6" VENT = 1.625SF X 4 = 6.5SF  
 3"x2'-0" = 0.5 SF X 2 = 1.0 SF  
 TOTAL VENTING PROVIDED = 7.5 SF

**FOUNDATION - WOOD SILL** 24' X 40' 50 PSF LL  
 SCALE 1/4" = 1'

**CBC 1999**

**PC**

IDENTIFICATION STAMP  
 DIV. OF THE STATE ARCHITECT  
 OFFICE OF REGULATION SERVICES  
 04 101984  
 AC DATE 04/03/2000

IDENTIFICATION STAMP  
 DIV. OF THE STATE ARCHITECT  
 OFFICE OF REGULATION SERVICES  
 APPROV 115000  
 AC DATE 10/22/99

REVISIONS	Electrical Engineer's Seal	Mechanical Engineer's Seal	Architect's Seal

Electrical Engineer's Seal

Mechanical Engineer's Seal

Architect's Seal

Architect's Seal

IDENTIFICATION STAMP  
 DIV. OF THE STATE ARCHITECT  
 OFFICE OF REGULATION SERVICES  
 PC-04  
 101419  
 AC DATE 01/23/99

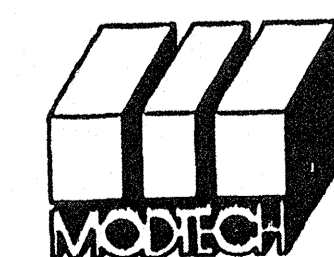

**MODTECH INC.**  
 2830 BARRETT AVENUE  
 PERRIS, CALIF. 92572  
 PH (909) 943-4014  
 FAX (909) 940-0427

PROJECT NUMBER: © MODTECH, INC. 1999

DRAWN BY:  
 DATE:  
 CHECKED BY: SS  
 DATE: 10/22/99

**FOUNDATION PLAN**

MODTECH Index No.  
**F1.0**

FILE PATH: 2440-0-F1-00.r3

PROJECT NO. PC-04-101419

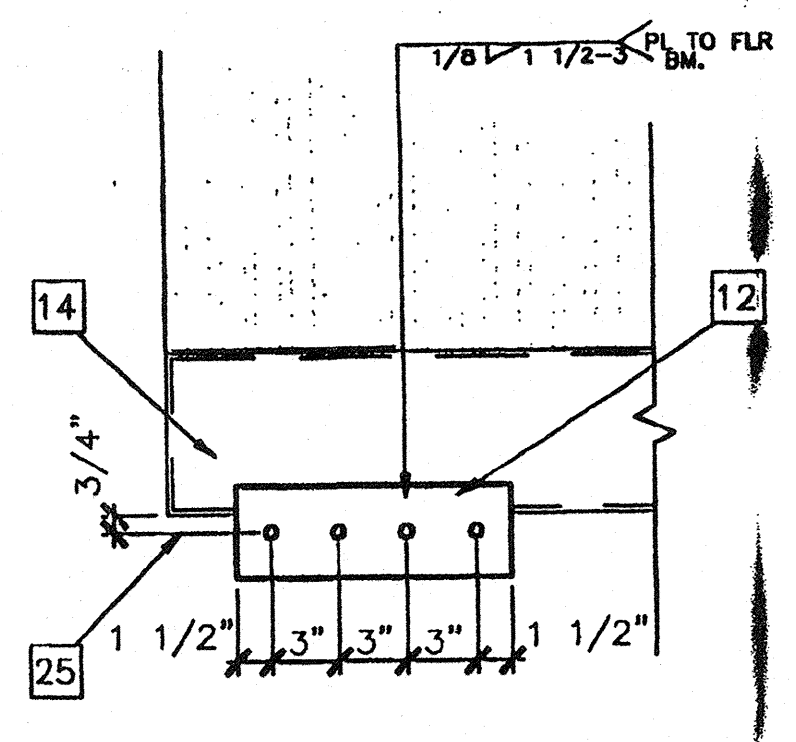

9 SCALE: 1 1/2"=1'-0"  
ALTERNATE TIE PLATE

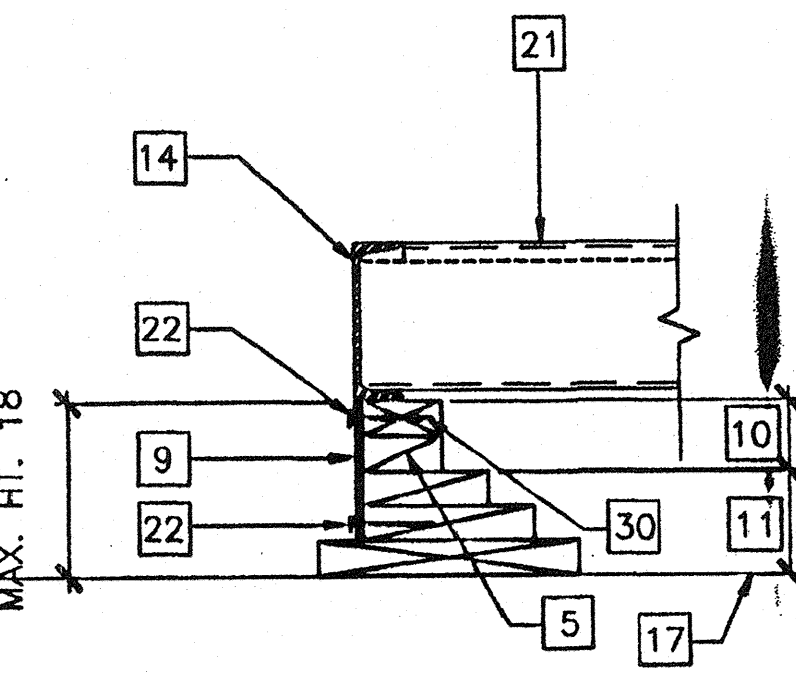

10 SCALE: 1 1/2"=1'-0"  
ADD BLK'S/SHIMS TO LEVEL FOUND.

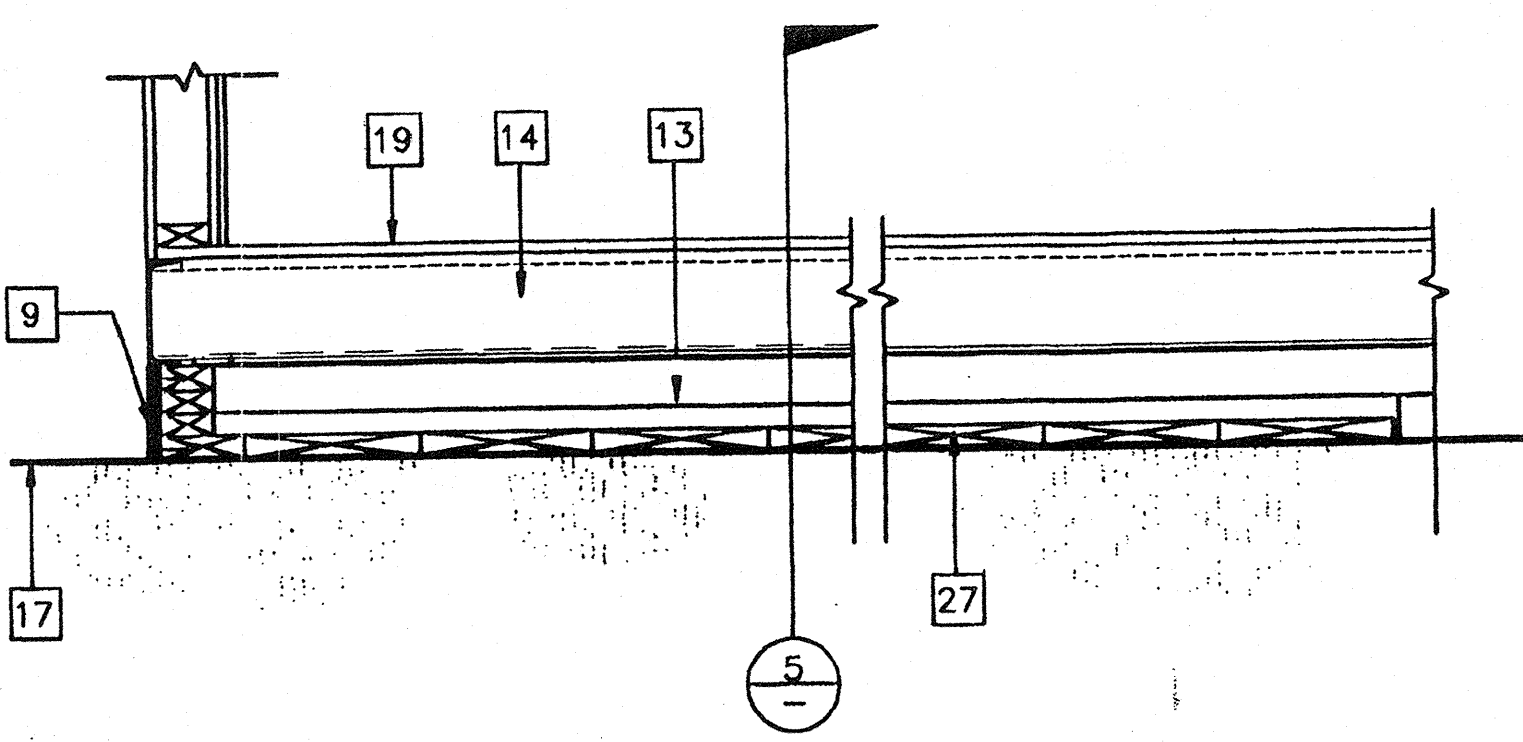

6 SCALE: 1 1/2"=1'-0"  
MODLINE PAD @ END WALL

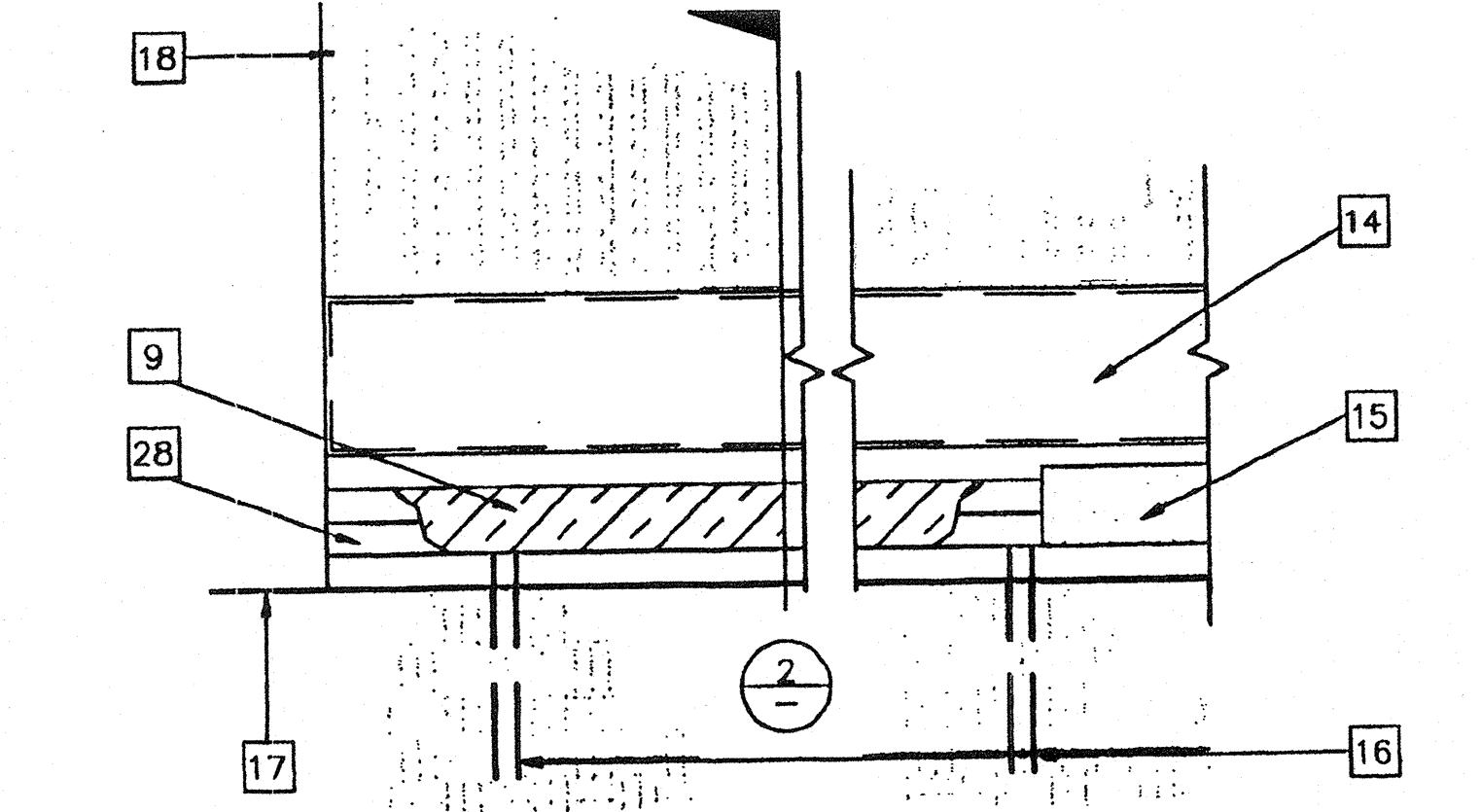

7 SCALE: 1 1/2"=1'-0"  
FOUNDATION ELEVATION @ SIDE WALL

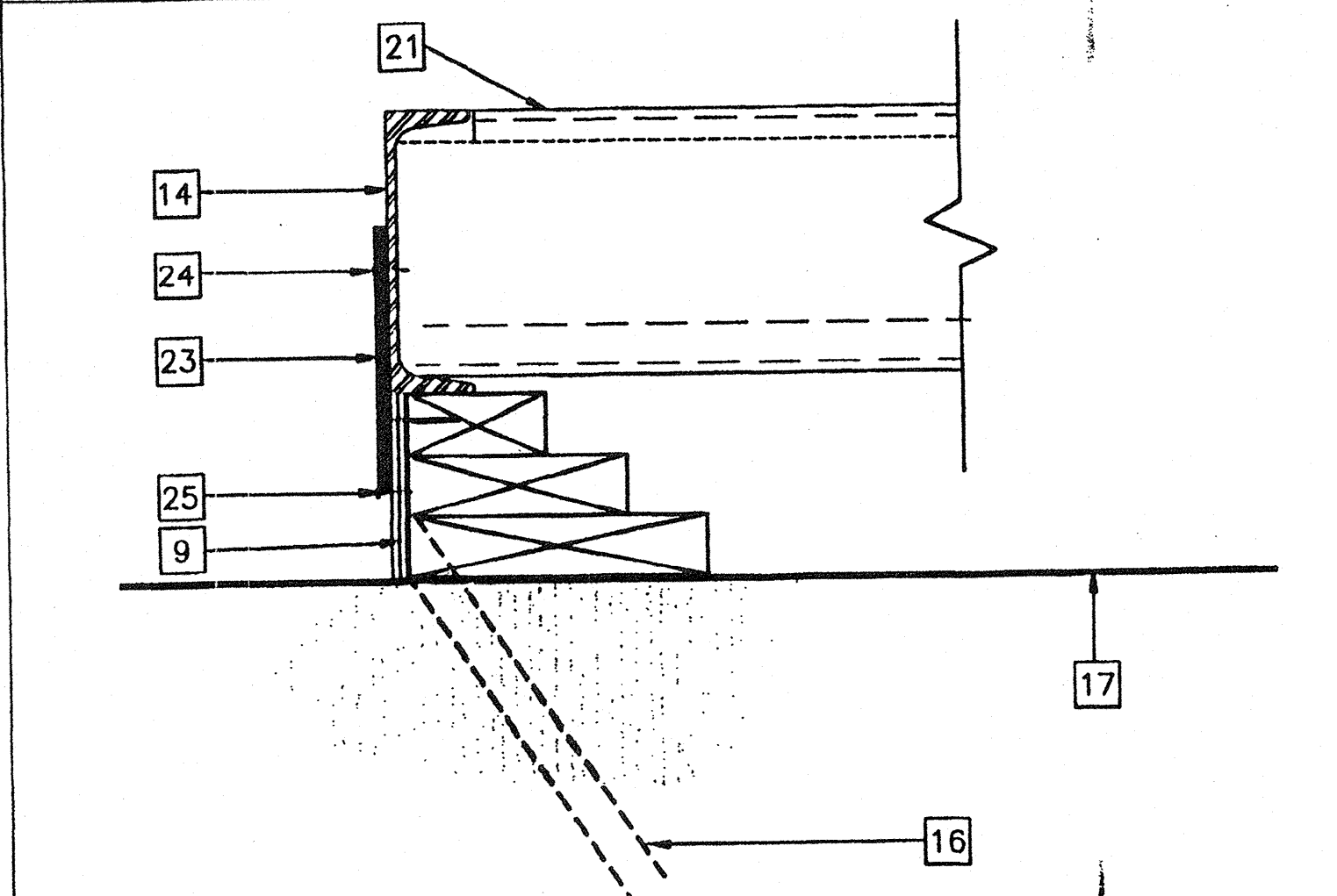

8 SCALE: 3"=1'-0"  
TYPICAL TIE PLATE

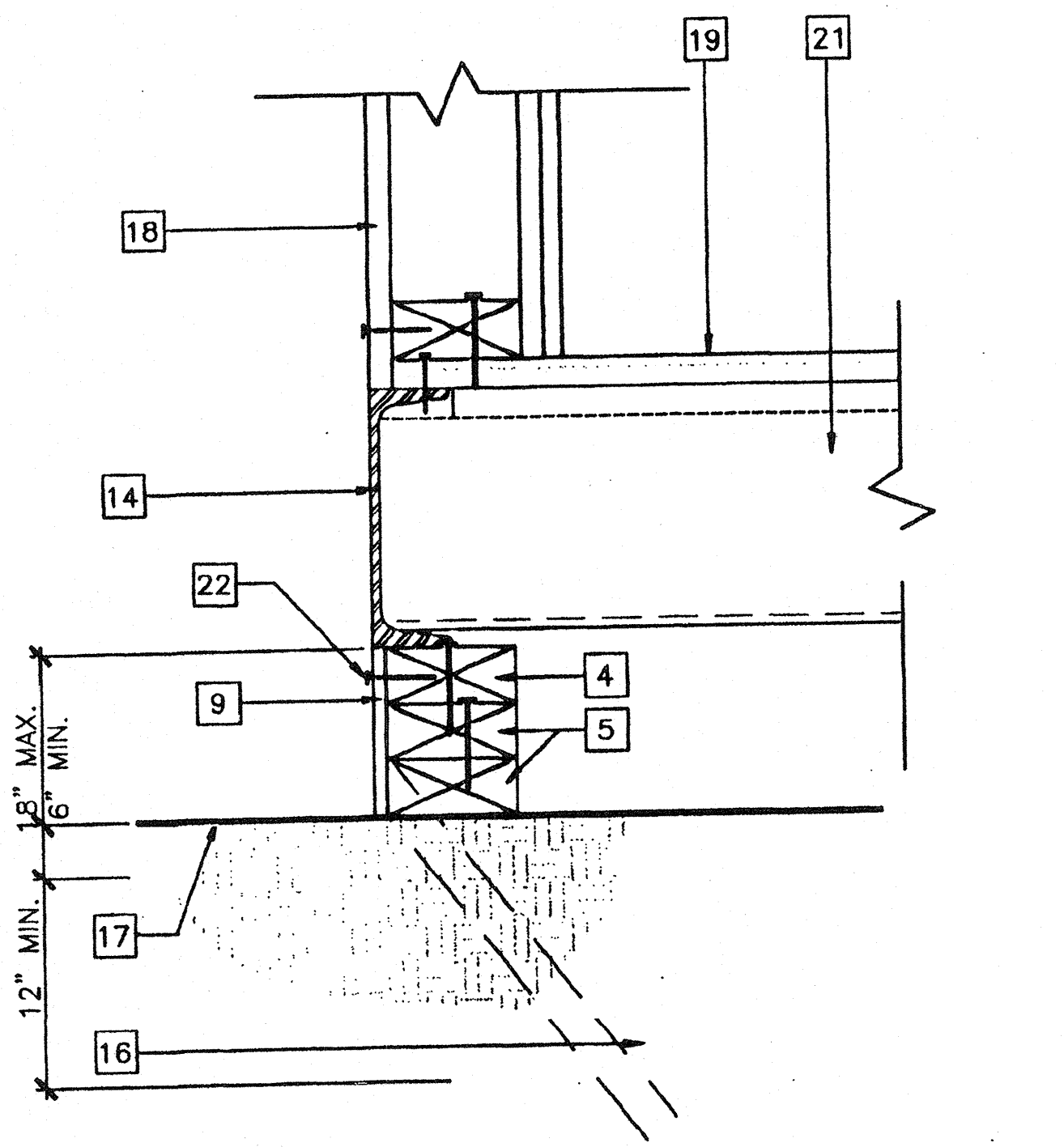

3 SCALE: 3"=1'-0"  
FOUNDATION @ END WALL

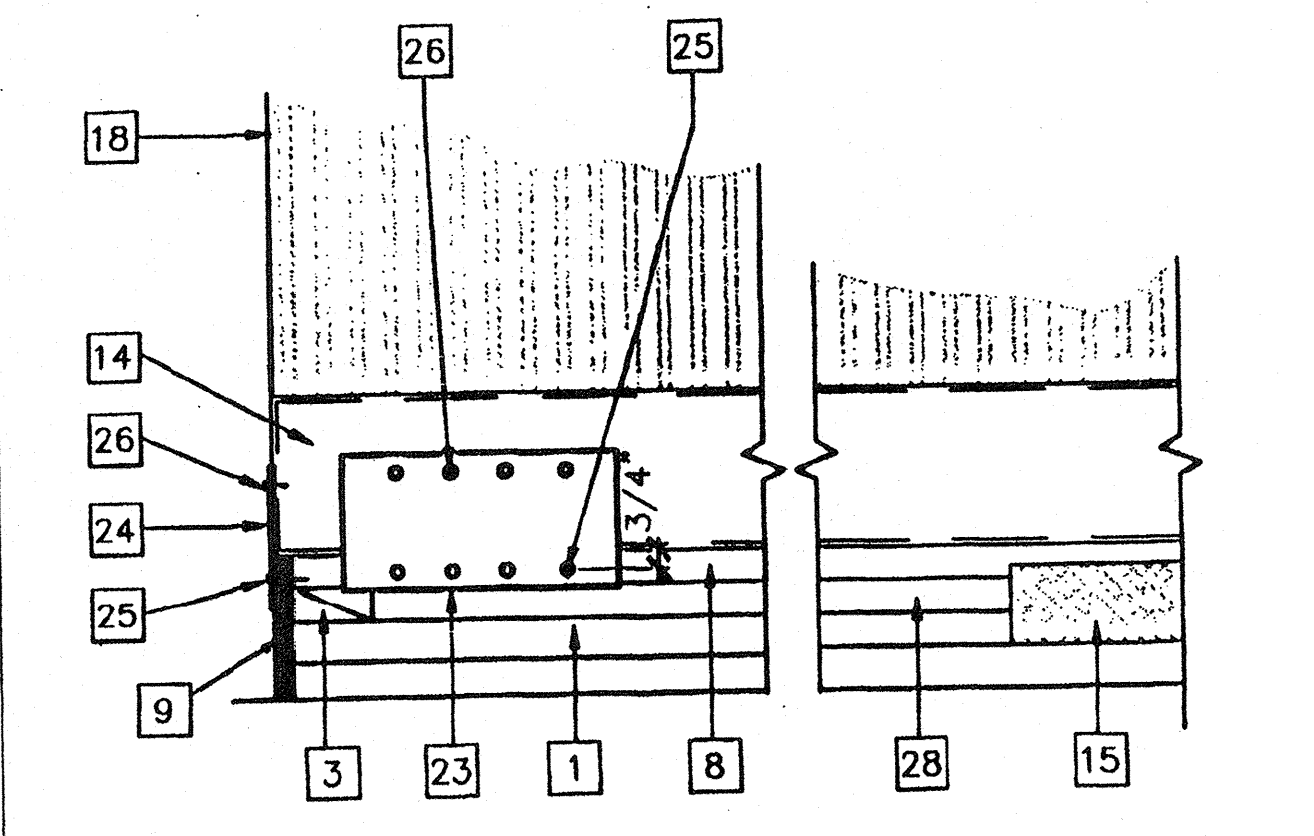

4 SCALE: 1 1/2"=1'-0"  
DETAIL @ FOUNDATION CORNER

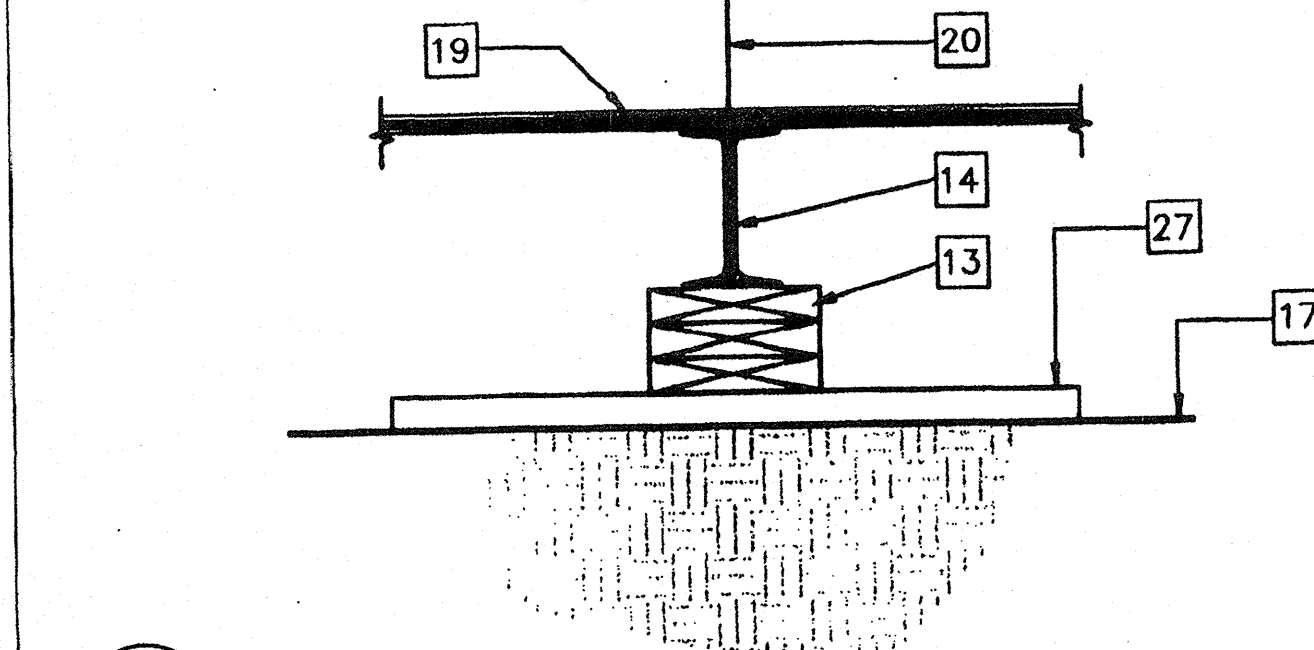

5 SCALE: 1 1/2"=1'-0"  
FOUNDATION PAD @ MODLINE

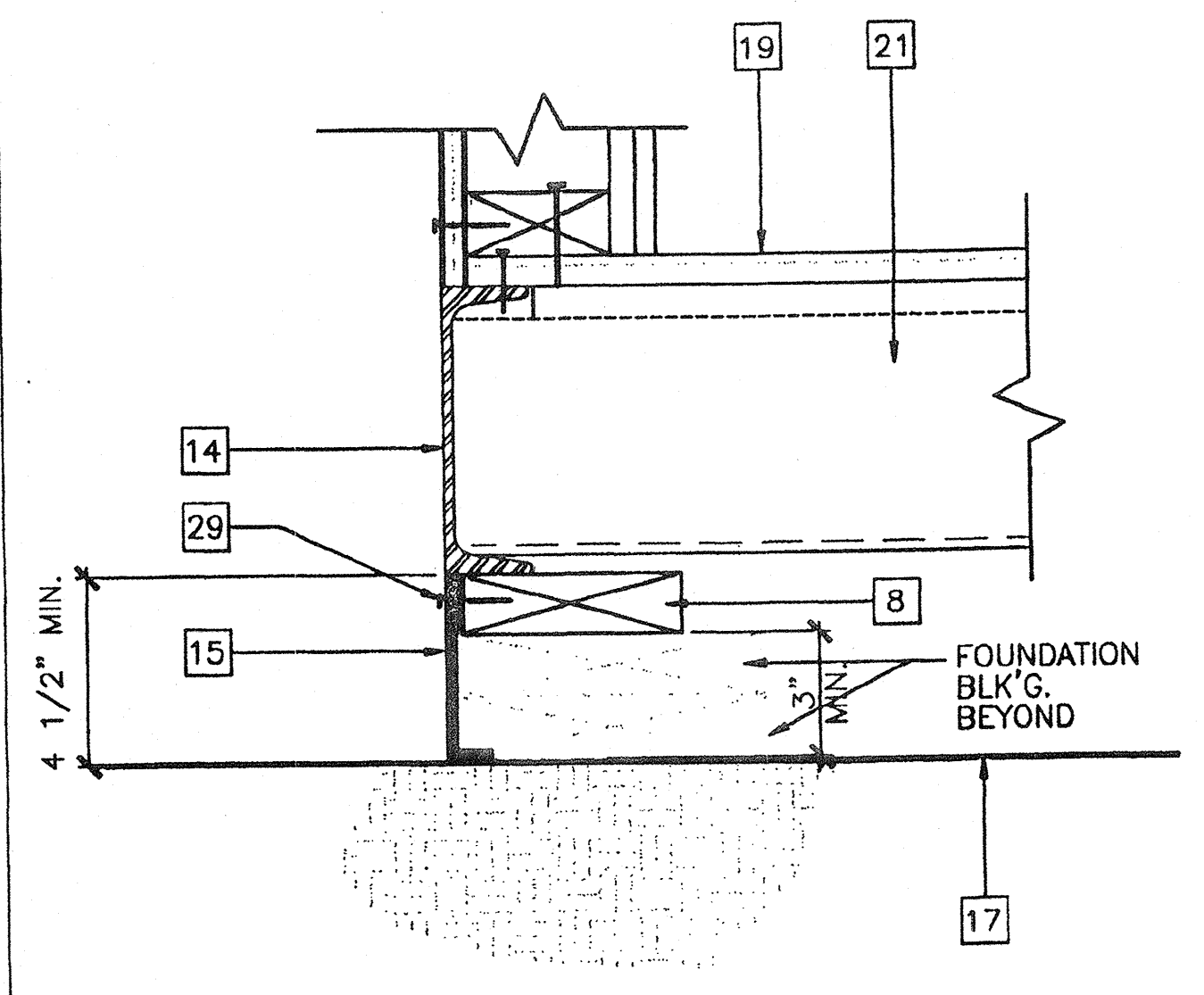

1 SCALE: 3"=1'-0"  
FOUNDATION VENT

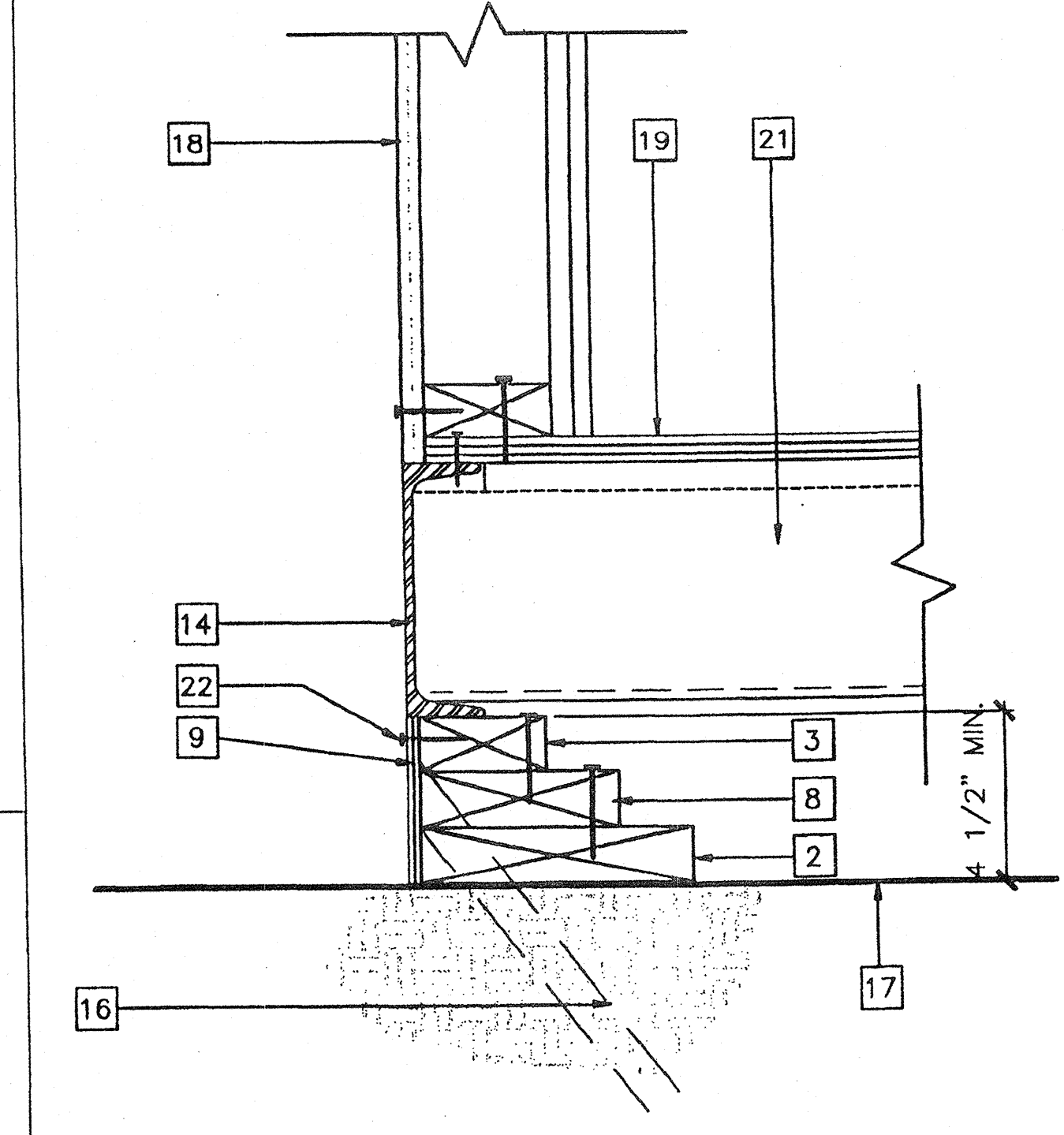

2 SCALE: 3"=1'-0"  
FOUNDATION @ SIDE WALL

- KEY NOTES**
- 1 2X12 SILL PLATE SEE FOUND. PLAN FOR LENGTH
  - 2 2X8 TOP PLATE W/16d AT MAX. 5" O.C. TO SILL PLATE
  - 3 2X4 CONT. TOP PLATE W/16d AT MAX. 12" O.C.
  - 4 2X4 TOP PLATE CONT. W/16d AT MAX. 12" O.C.
  - 5 2X4 BLOCKING W/16d MAX. 12" O.C. TO SILL PLATE
  - 6 NOT USED
  - 7 NOT USED
  - 8 2X6 BLOCKING W/16d AT MAX. 12" O.C.
  - 9 MIN. 5/8" PLYWOOD SKIRTING W/10d BOX @ MIN. 4" O.C. AT ENDWALLS & 6" O.C. AT SIDEWALLS E.N. & TYP. 12" O.C. FN.
  - 10 ADD BLOCKING OR SHIMS AS REQ. TO MAX. HT. SEE DETAIL #2
  - 11 MIN. FOUNDATION HEIGHT. SEE DETAIL #2
  - 12 10 GA. PLATE 4" X 12"
  - 13 2X8 BLOCKING FACE OR TOE NAIL 16d AT MAX. 12" O.C. ADD BLKS. OR SHIMS AS REQ'D
  - 14 FLOOR FRAME BEAM. SEE STRUCTURAL
  - 15 VENT MIN. 3" X 6'-6" TYP. 4-PLACES = 6.5 SF. 2 VENTS AT 3" X 2'-0" = 1.0 SF. = 7.5 SQ. FT. TOTAL
  - 16 SILL RESTRAINT 1" DIA. PIPE. SEE FOUND. PLAN FOR LOCATION - 24" LONG
  - 17 FINISH GRADE
  - 18 EXTERIOR FINISH
  - 19 PLYWOOD SUBFLOOR
  - 20 MOD-LINE
  - 21 FLOOR-JOIST
  - 22 EN SEE NOTE #9
  - 23 6" X 12" X 10GA. PLATE W/(4) #10 SMS TO FLR. & (4) 1/4" DIA. X 3" LAG TO FOUND. TOP PLATE
  - 24 6" X 12" X 10 GA. PLATE
  - 25 1/4" DIA. X 3" LG. LAG SCREW TYP. 4-PLACES
  - 26 #10 S.T.S. TYP. 4-PLACES
  - 27 2" X 12" X 2'-6" SILL PLATE. SEE FOUND. PLAN FOR QUANTITY REQ'D
  - 28 2X8 BLOCKING W/16d AT MAX. 6" O.C. MIN. 3 PER BLOCK. (MAY VARY ACCORDING TO SITE)
  - 29 10d GALV. BOX NAIL AT MAX. 4" O.C.
  - 30 INSERT REQ'D 2X4 BLOCKING OR PLYWOOD SHIM W/16d AT 12" O.C. FACE NAIL
  - 31 NOT USED
  - 32 NOT USED

IDENTIFICATION STAMP  
DIV. OF THE STATE ARCHITECT  
OFFICE OF REGULATION SERVICES  
04 101984  
AC FLS SS  
DATE MAR 09 2000

IDENTIFICATION STAMP  
DIV. OF THE STATE ARCHITECT  
APPROX 115000  
AC FLS SS  
DATE 7/24/14

REVISIONS	Electrical Engineer's Seal	Mechanical Engineer's Seal	Structural Engineer's Seal	Architect's Seal

Electrical Engineer's Seal

Mechanical Engineer's Seal

Structural Engineer's Seal

Architect's Seal

IDENTIFICATION STAMP  
DIV. OF THE STATE ARCHITECT  
OFFICE OF REGULATION SERVICES  
PC-04  
10419  
AC FLS SS  
DATE OCT 24 1999

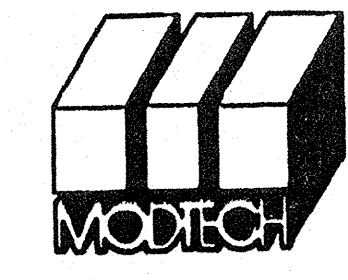

**MODTECH INC.**  
2830 BARRETT AVENUE  
PERRIS, CALIF. 92572  
PH (909) 943-4014  
FAX (909) 940-0427

PROJECT NUMBER:

© MODTECH, INC. 1999

DRAWN BY:  
DATE:  
CHECKED BY: SS  
DATE: 10/22/17  
MODTECH Index No.

**FOUNDATION DETAILS**

**F2.0**

FILE PATH: 2440-0-F2-0.DWG PROJECT NO. PC-04-101419

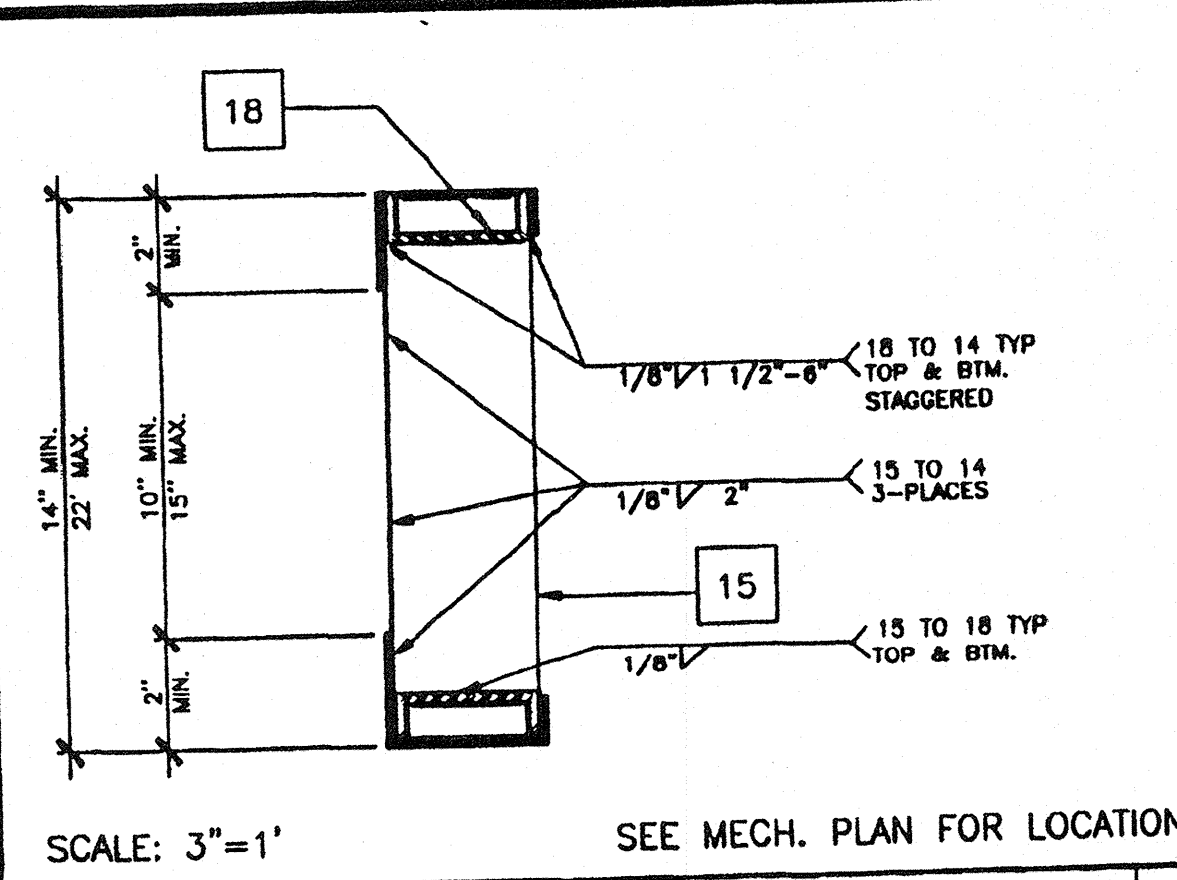

MECH. DUCT OPENING IN ROOF BM. 8

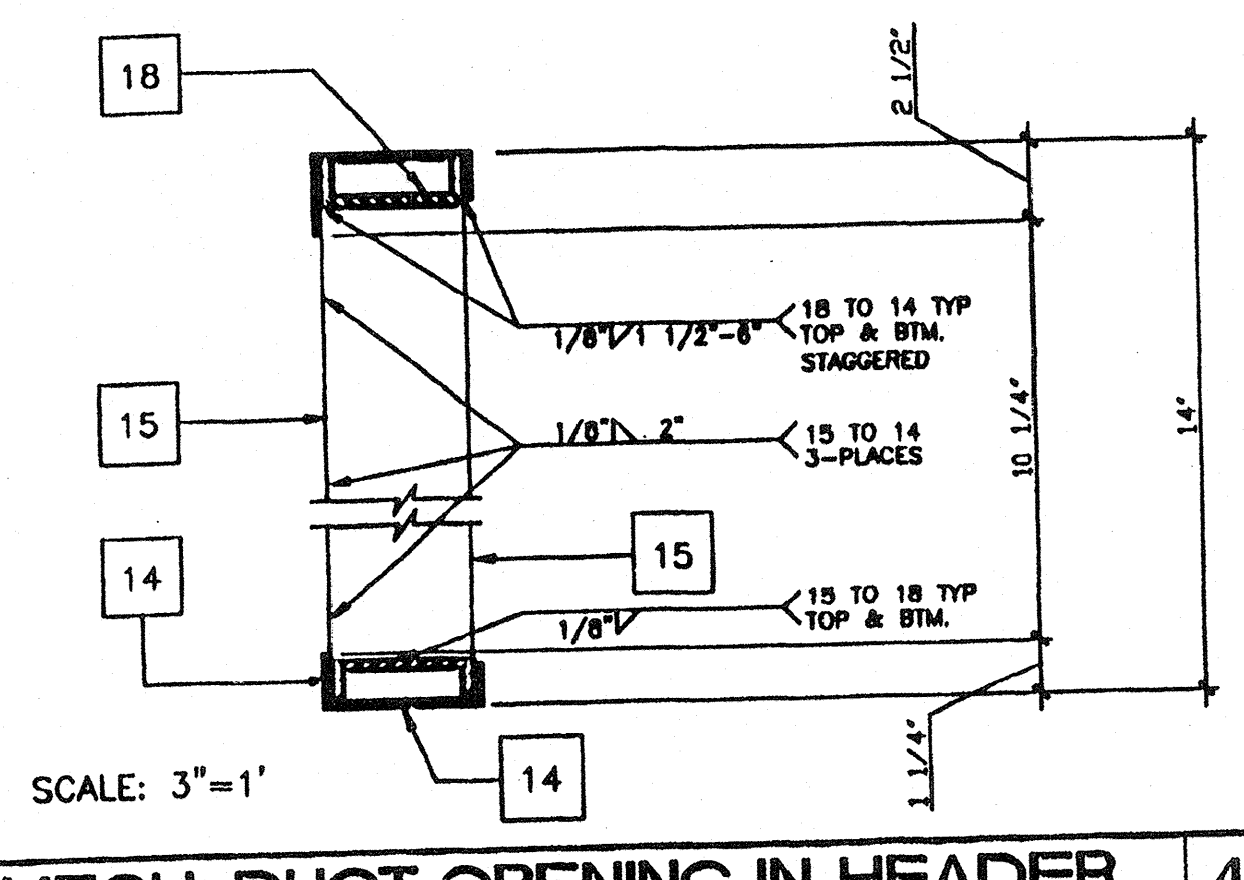

MECH. DUCT OPENING IN HEADER 4

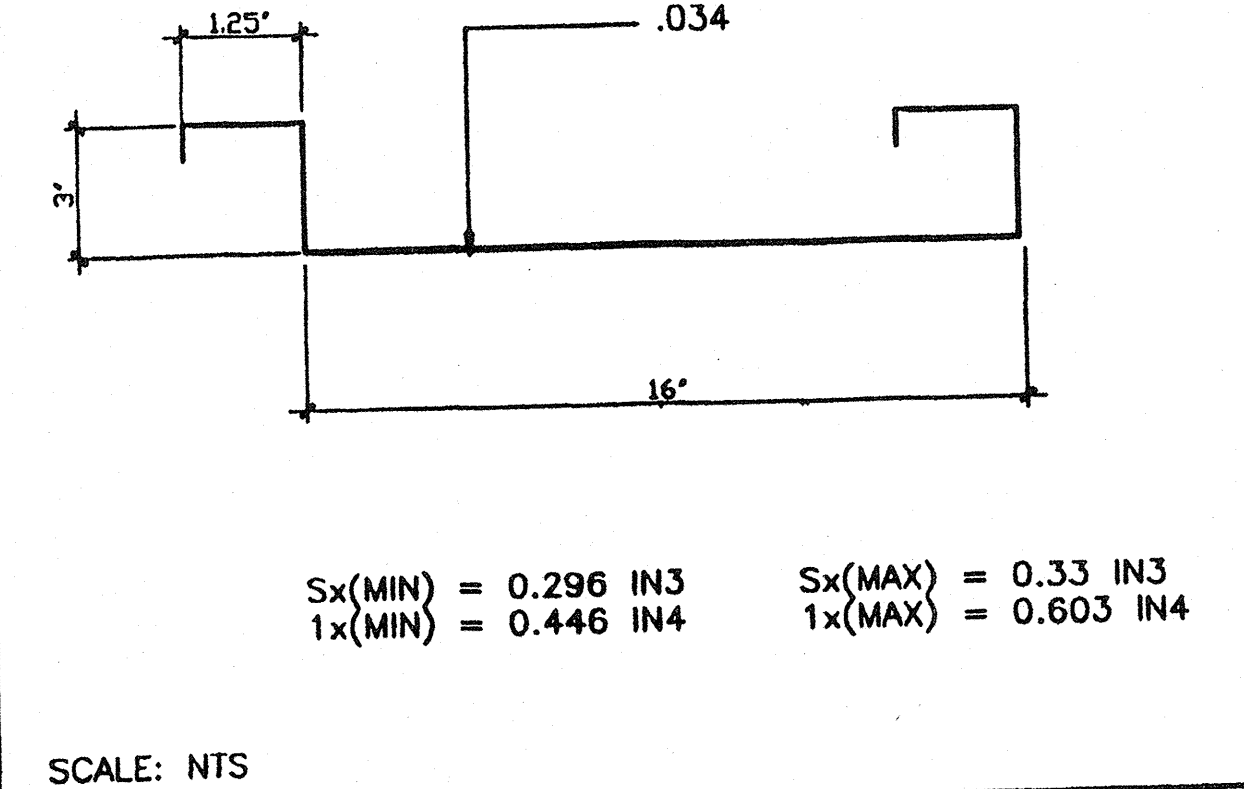

ROOF PAN (22GA.) 5

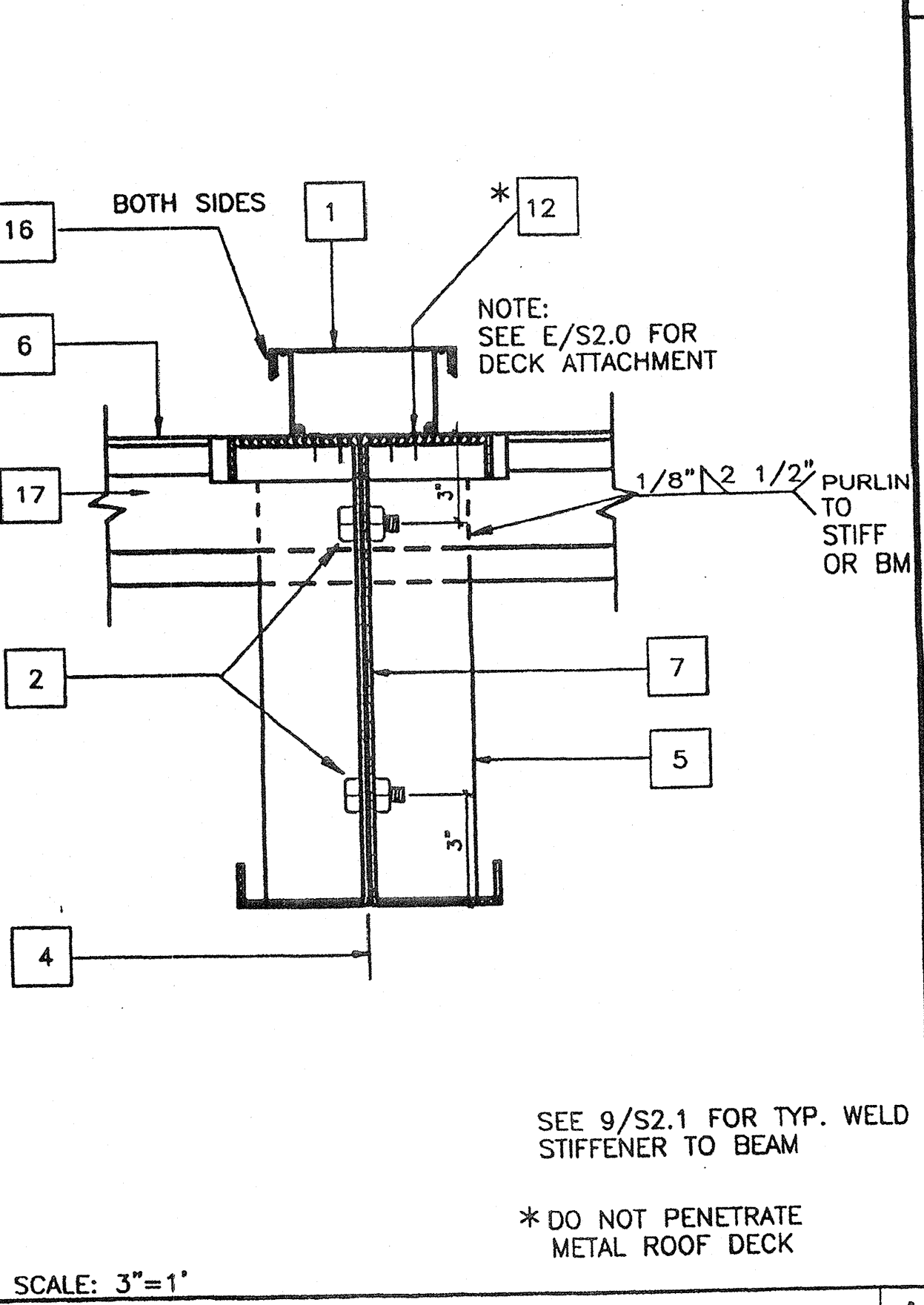

ROOFING @ MODLINE 1

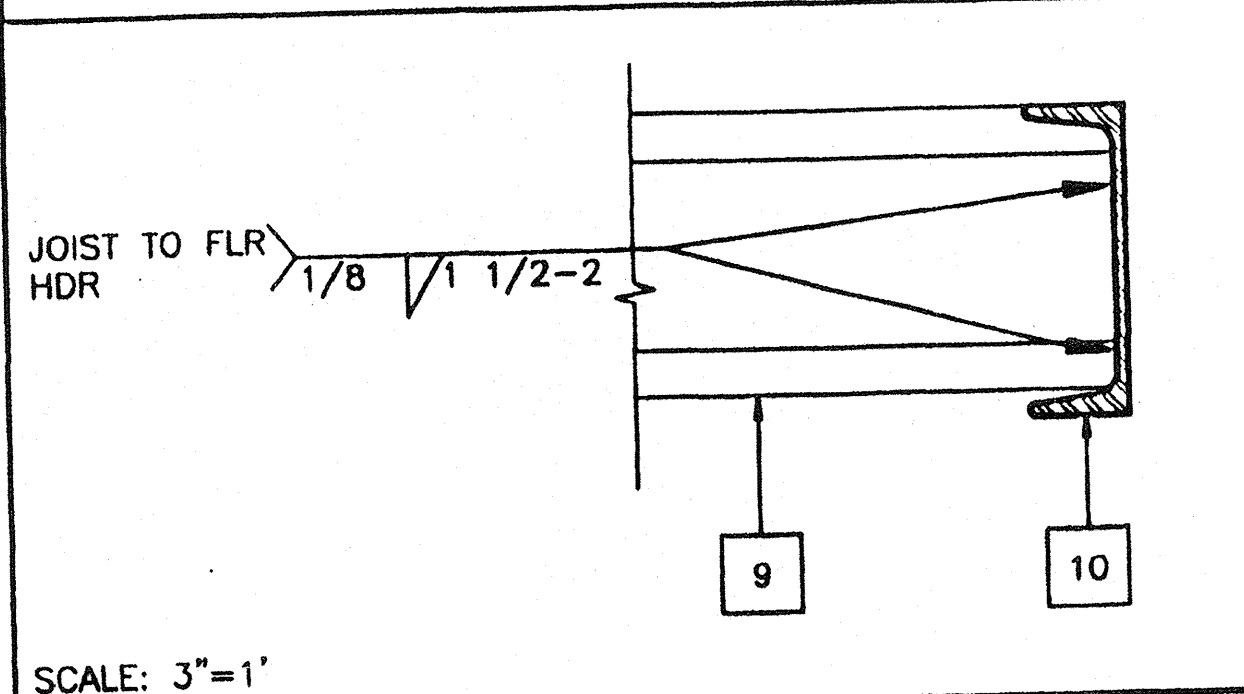

FLOOR FRAME/JOIST TO BEAM 6

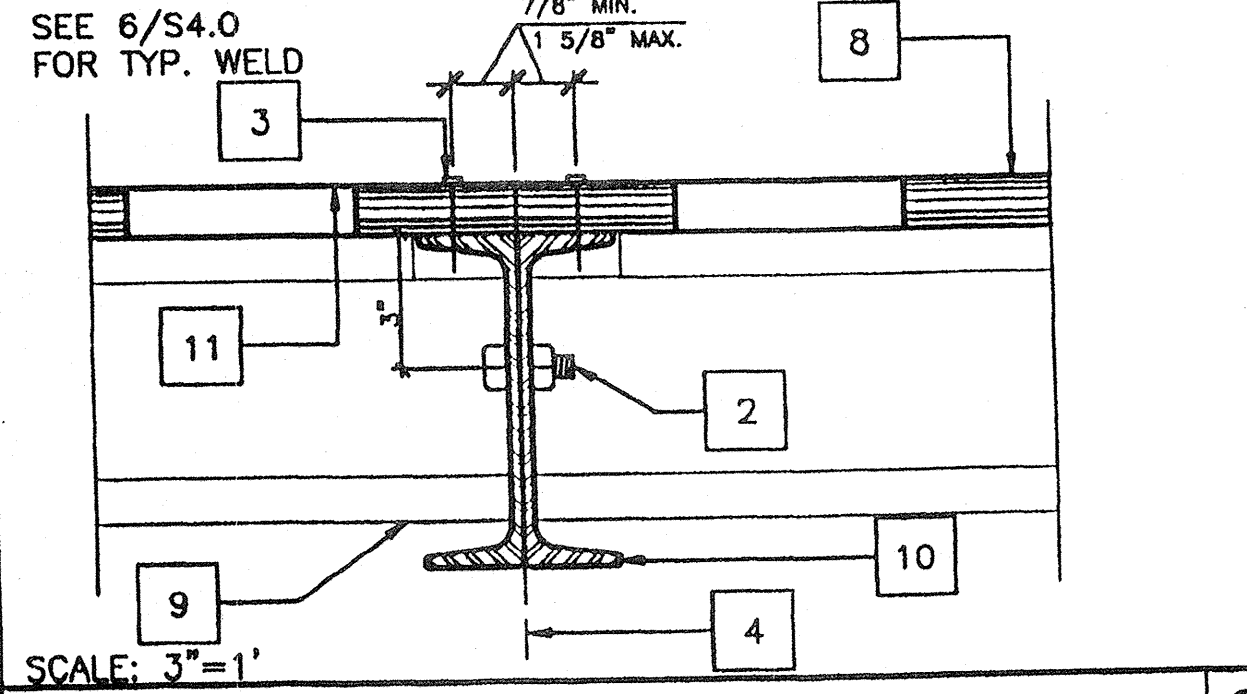

MODULE JOINT AT FLR. 12'-0" 2

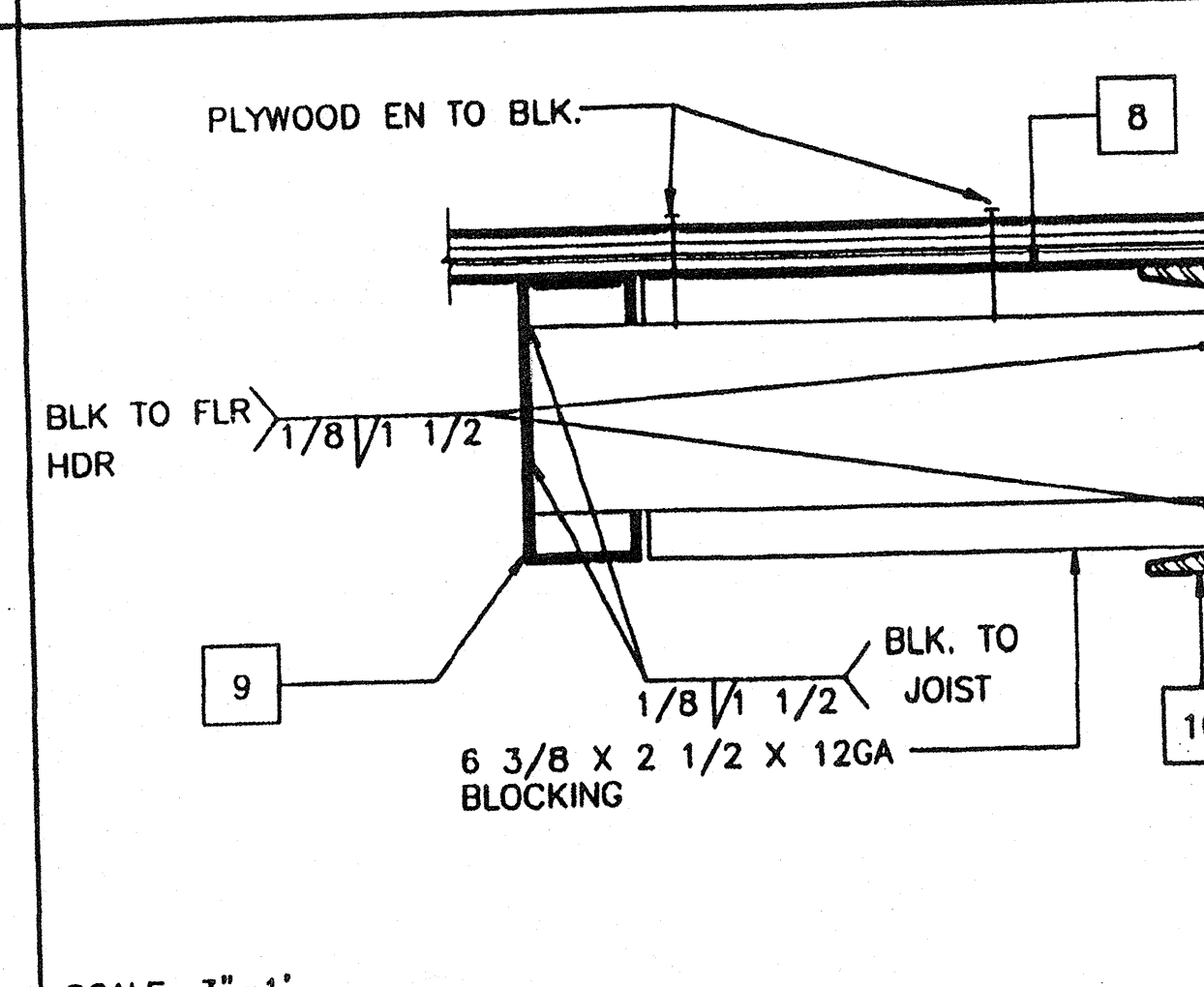

BLOCK AT MIDSPAN 10

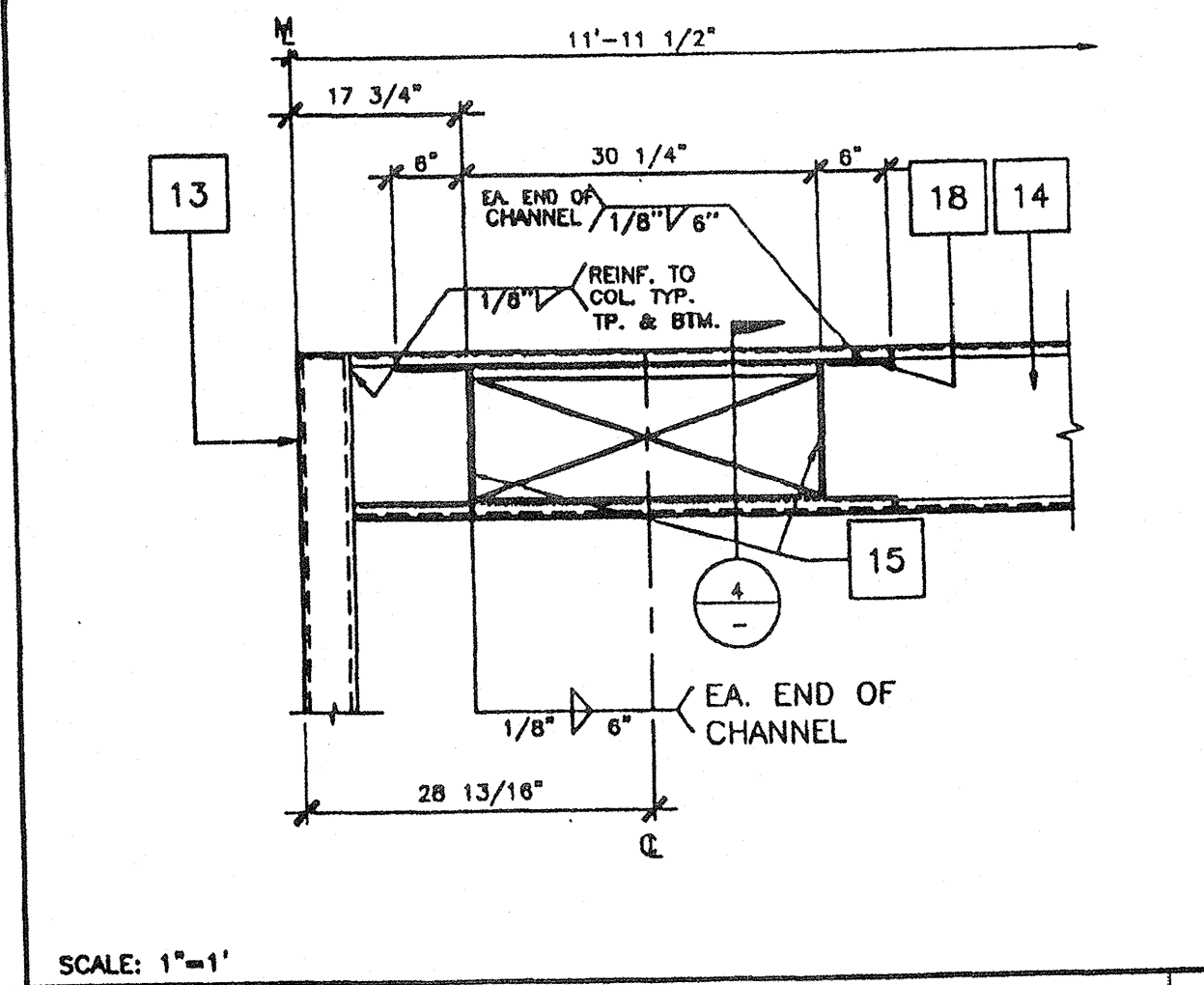

ELEVATION-OPENING 7

KEY NOTES

- 1 CAP CLOSURE AT RIDGE 26GA. GALV. W//10 TYPE FASTENERS W/NEOPRENE WASHERS TO RIB BOTH SIDES OF MODLINE. SET CAP IN SLANT. BOTH SIDES
- 2 5/8" M.B. A307 MODULE JOINT (SEE STRUCTURAL PLAN FOR LOCATION) AT 8" O.C.
- 3 E.N.
- 4 MODULE JOINT
- 5 1/4" THK X 3" FULL DEPTH STIFFENER PLATE AT RIDGE ONLY (SEE 9/S2.1)
- 6 STANDING ROOF SEAM (SEE A2.0)
- 7 ROOF BEAM SEE 1/S2.1 & 7/S2.1
- 8 PLYWOOD FLOOR SHEATHING
- 9 FLOOR JOIST SEE 6/S2.1
- 10 FLOOR BEAM SEE 5/S2.1
- 11 HAND HOLE AT BOLT LOCATION
- 12 #14 STSMS.
- 13 3 1/2"x3 1/2"x1/4" STEEL TUBE COLUMN. SEE 12/S2.1
- 14 ROOF HEADER SEE 3/S2.1
- 15 1/4" STIFFENER PLATE SEE 9/S2.1 FOR TYP. WELD
- 16 SEALANT
- 17 ROOF PURLIN SEE 2/S2.1
- 18 3 1/4" X 1" X 45 11/16" LG X 10GA CHANNEL TOP AND BOTTOM OF OPENING

CBC 1993  
PC

IDENTIFICATION STAMP  
DIV. OF THE STATE ARCHITECT  
OFFICE OF REGULATION SERVICES  
04 101984  
AC FLS SS  
DATE MAR 09 2000

IDENTIFICATION STAMP  
DIV. OF THE STATE ARCHITECT  
APPROX 115000  
AC FLS SS JB  
DATE 7/24/14

REVISIONS	Electrical Engineer's Seal	Mechanical Engineer's Seal	Structural Engineer's Seal	Architect's Seal

IDENTIFICATION STAMP  
DIV. OF THE STATE ARCHITECT  
OFFICE OF REGULATION SERVICES  
PC-04  
101419  
AC FLS SS  
DATE OCT 25 1000

MODTECH INC.  
2830 BARRETT AVENUE  
PERRIS, CALIF. 92572  
PH (909) 943-4014  
FAX (909) 940-0427

PROJECT NUMBER: \_\_\_\_\_  
© MODTECH, INC. 1999

DRAWN BY: \_\_\_\_\_  
CHECKED BY: SS  
DATE: 10/22/99

MODTECH Index No. \_\_\_\_\_

**STRUCTURAL DETAILS**

**S1.2**

PROJECT NO. PC-04-101419

### ELECTRICAL PANEL SCHEDULE

MAIN: 100 AMP 12 POLE	PANEL A				FEED: REAR				
	LOCATION: REAR/INTERIOR				MOUNTING: FLUSH				
LOAD	WATTS		BREAKER		WATTS		LOAD		
	AP	BP	Amps	P	AP	BP			
RECEPTACLE (4)	720		20	1	2	2	50	3360	HVAC (3 1/2T)
RECEPTACLE/CLOCK (5)		720	20	1	3	4		3360	HVAC (3 1/2T)
				5	6	2	30	2500	HEAT STRIPS (DKW)
				7	8			2500	HEAT STRIPS (DKW)
INT/EXT LIGHTS (11)	760		20	1	9	10			
INT. LIGHTS (10)		700	20	1	11	12			
WATTS/PHASE	A = 7340 1480 1420				B = 7320		WATTS/PHASE		
TOTAL	14810	WATTS	62	AMPS	120/240	VOLTS	SINGLE #	THREE	WIRE
NCL =	13080	WATTS							

### GENERAL GROUNDING NOTES

- EACH BUILDING SHALL BE SEPARATELY GROUNDED WITH A 3/4" RD. X 8' COPPERCLAD STEEL GROUND ROD, WHERE ROCK BOTTOM IS ENCOUNTERED, ROD SHALL BE DRIVEN AT AN ANGLE NOT TO EXCEED 45 DEGREE'S FROM THE VERTICAL OR SHALL BE BURIED IN A TRENCH THAT IS AT LEAST 30" DEEP (BY SITE ELECTRICAL)
- TESTING: TEST FOR RESISTANCE TO GROUND, IF RESISTANCE EXCEEDS 25 OHMS, INSTALL ADDITIONAL GROUND RODS SEPARATED AT LEAST 6'-0" UNTIL RESISTANCE IS REDUCED TO 25 OHMS OR LESS. (BY SITE ELECTRICAL)
- APPROVAL OF THIS PLAN DOES NOT CONSTITUTE APPROVAL OF THIS FIRE ALARM FOR ALL SITES, THE FIRE ALARM SYSTEM AND/OR COMPONENTS MAYBE REQUIRED TO BE CHANGED DUE TO SITE LOCATION, EXISTING CONDITIONS OR INCOMPATIBLE COMPONENTS.
- GROUND MG TEST SHALL BE DONE IN THE PRESENCE OF THE PROJECT INSPECTOR, ALL GROUNDING SHALL BE IN ACCORDANCE WITH CEC ARTICLE 250.

### ELECTRICAL LEGEND

- 2'x4' 4 TUBE FLUORESCENT LIGHT FIXTURE
- EXTERIOR LIGHT FIXTURE AT +93" AFF
- SWITCH AT +48" AFF
- DUPLEX WALL RECEPTACLE 15A 125V 3 WIRE AT +18" AFF UNW
- HVAC UNIT (HV)
- 4SD J-BOX FOR FIRE ALARM PULL STATION AT +48" AFF, 3/4" CO TO PULLSTRING
- 4SD J-BOX FOR FIRE ALARM STROBE AT +80" AFF, 3/4" CO TO PULLSTRING
- 4SD J-BOX FOR FIRE ALARM HORN AT +18" AFF, 3/4" CO TO PULLSTRING
- WEATHER PROOF GUTTER BOX (6"x6"x4") AT +18" AFF RECEIVE 3/4" CO FROM FA DEVICE, PULLSTRING
- ELECTRICAL PANEL AT +80" AFF TO CENTERLINE 1 1/4" POWER NIPPLE POC, GND JUMPER BY SITE ELECT
- CLOCK AT +90" AFF
- DATA LINE
- 4SD J-BOX FOR OPTIONAL SMOKE DETECTOR (CFL)
- 4SD J-BOX FOR OPTIONAL FIRE ALARM (CFL)

\* SMOKE & HEAT DETECTORS SHOWN ARE FOR OPTION AUTOMATIC DETECTION. IF ELECTED AS AN OPTION THEY MUST BE PROVIDED BY DISTRICT. NO PROVISIONS WILL BE MADE UNDER THIS CONTRACT.

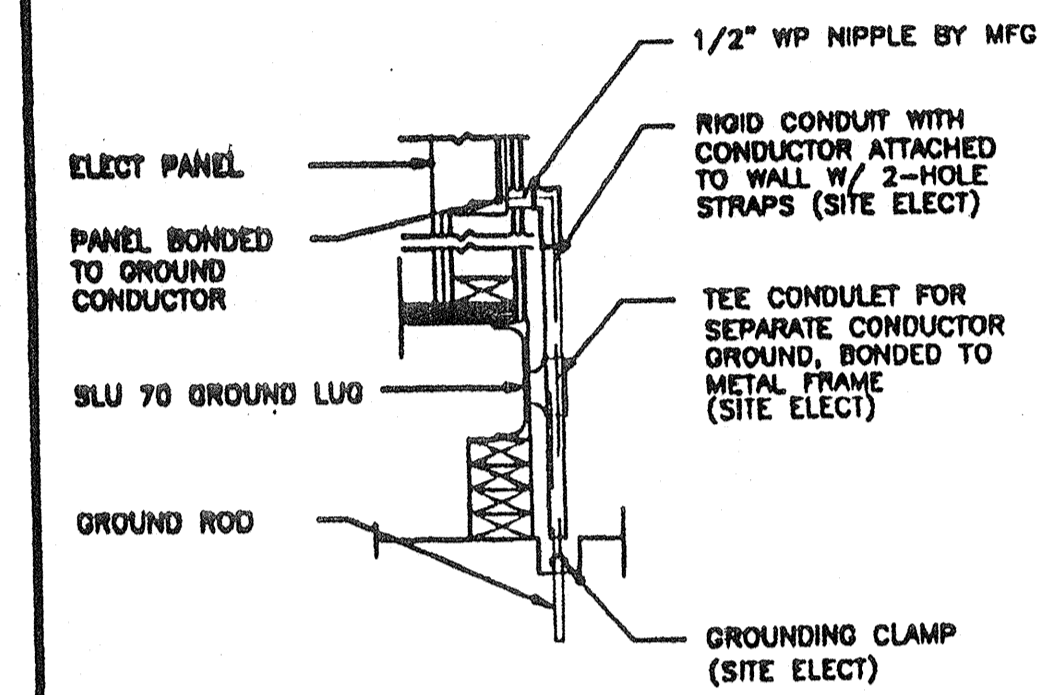
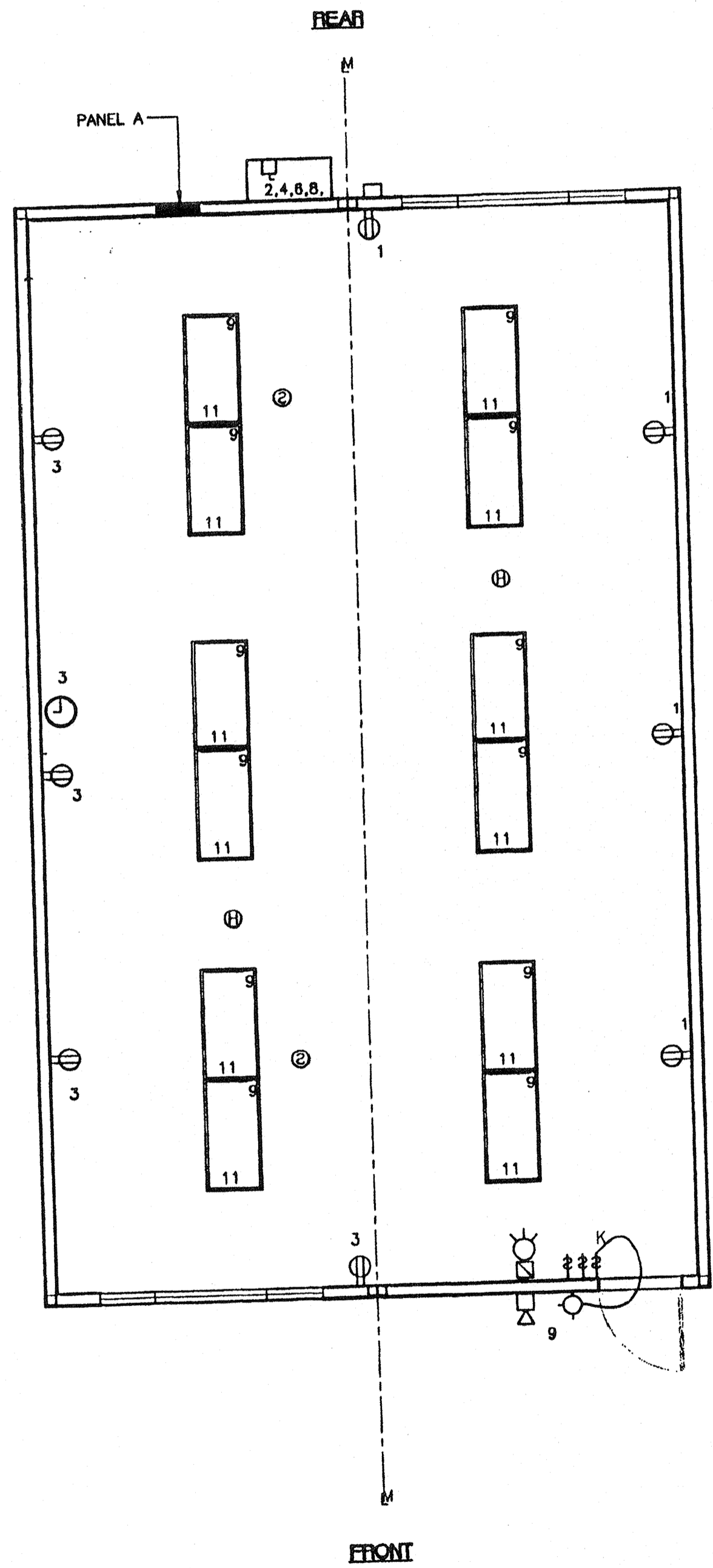

TYP GROUNDING DETAIL 1

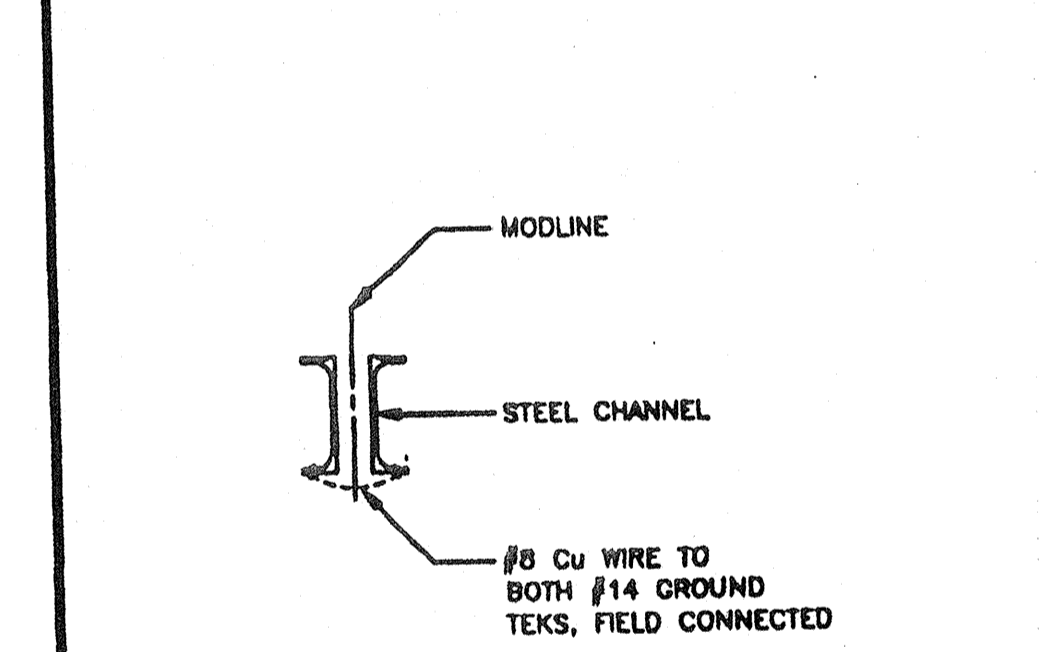

GROUND JUMPER • MOD LINE 2

### NOTES

- SCHOOL EQUIPMENT ANCHORAGE  
THE FOLLOWING IS FOR THE ARCHITECTS INFORMATION ONLY:  
THE SEISMIC ANCHORAGE OF ELECTRICAL EQUIPMENT SHALL CONFORM TO COR TITLE 24, SECTION 1632A AND TABLE 16A-0. ANCHORAGE DETAILS FOR ROOF/FLOOR MOUNTED EQUIPMENT WEIGHING LESS THAN 400 LBS & HUNG EQUIPMENT WEIGHING LESS THAN 20 LBS MAY BE OMITTED FROM THE PLANS.  
FOR ELECTRICAL DRAWINGS:  
ALL ELECTRICAL EQUIPMENT SHALL BE BRACED OR ANCHORED TO RESIST A HORIZONTAL FORCE ACTING IN ANY DIRECTION USING THE FOLLOWING CRITERIA:  
EQUIPMENT ON GRADE 20% OF OPERATING WEIGHT  
EQUIPMENT ON STRUCTURE 30% OF OPERATING WEIGHT  
FOR FLEXIBLY MOUNTED EQUIPMENT USE 4 TIMES THE ABOVE VALUES, AND FOR SIMULTANEOUS VERTICAL FORCE USE 1/3 TIMES THE HORIZONTAL FORCE!  
THE ABOVE VALUES ARE FOR AN IMPORTANCE FACTOR, I = 1.0 AND SEISMIC ZONE, Z = 4  
WHERE ANCHORAGE DETAILS ARE NOT SHOWN ON THE DRAWINGS THE FIELD INSTALLATION SHALL BE SUBJECT TO THE APPROVAL OF THE ARCHITECT AND THE FIELD ENGINEER OF THE OFFICE OF THE STATE ARCHITECT.

ELECTRICAL PLAN (24'x40') SCALE: 1/4" = 1'-0"

CBC 1999

IDENTIFICATION STAMP  
DIV. OF THE STATE ARCHITECT  
OFFICE OF REGULATION SERVICES  
04 101984  
AC JWS  
DATE MAR 18 2014

IDENTIFICATION STAMP  
DIV. OF THE STATE ARCHITECT  
APPROX 110000  
AC JWS  
DATE 7/24/2014

REVISIONS	DESCRIPTION

Electrical Engineer's Seal  
Mechanical Engineer's Seal  
Architect's Seal

PC  
10419  
DATE 10/21/1999

**MODTECH INC.**  
2830 BARRETT AVENUE  
PERRIS, CALIF. 92572  
PH (909) 943-4014  
FAX (909) 940-0427

PROJECT NUMBER: © MODTECH, INC. 1999  
DRAWN BY: [Signature]  
CHECKED BY: [Signature]  
DATE: 10/22/99  
MODTECH Index No. **E1.0**  
**ELECTRICAL PLAN w/o DATA 24'x40'**

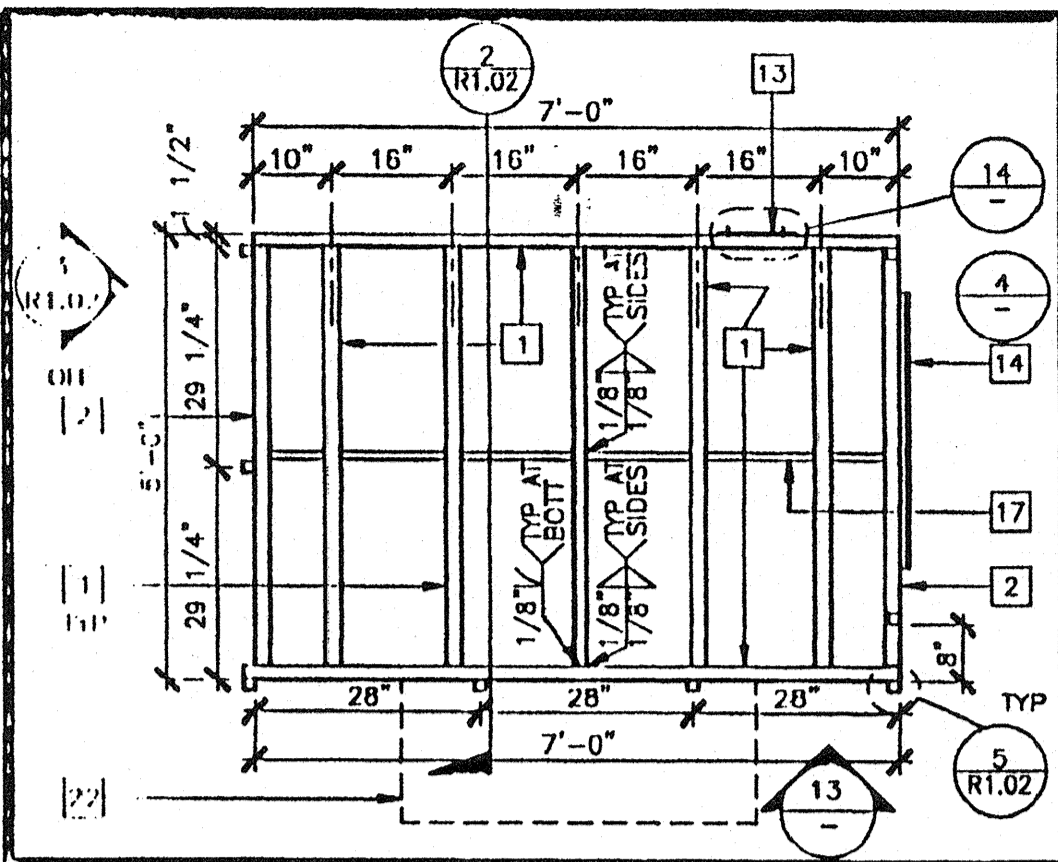

SCALE: NTS

LANDING FRAME 12

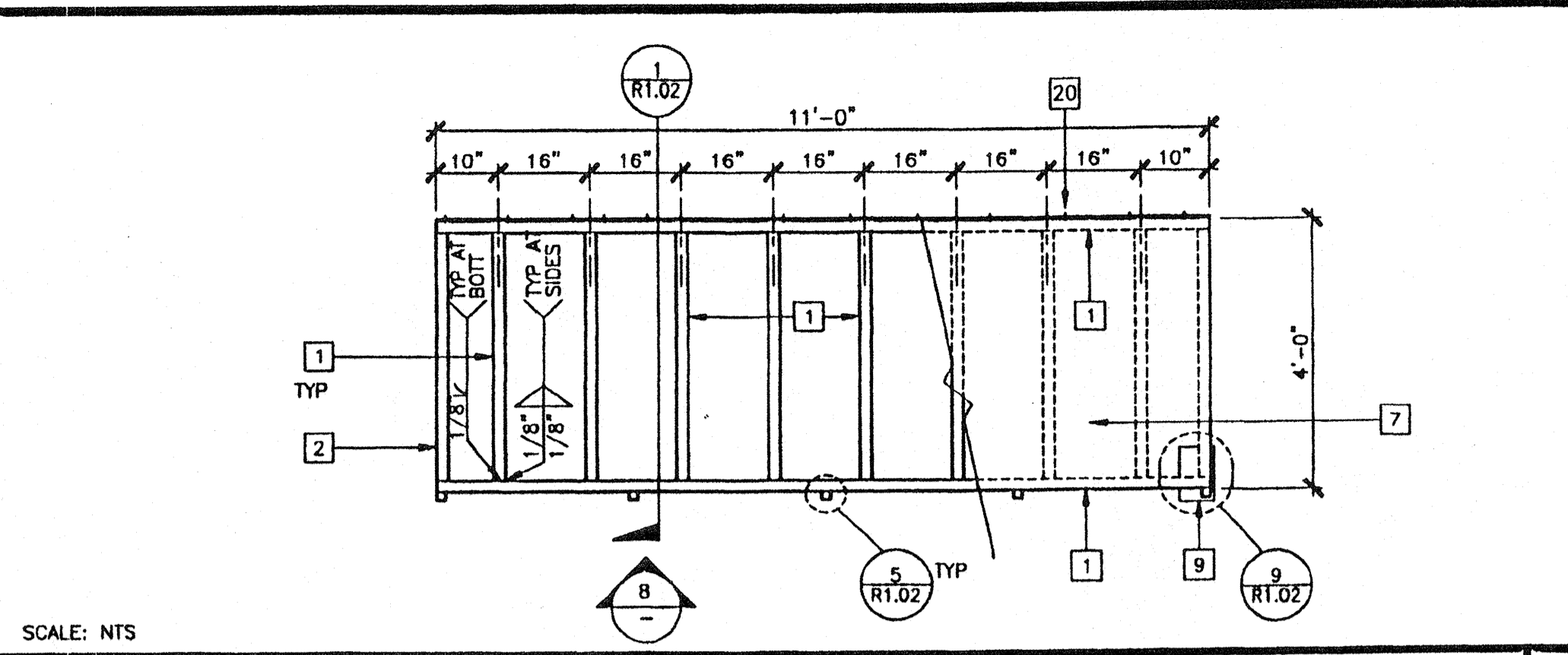

SCALE: NTS

RAMP FRAME 7

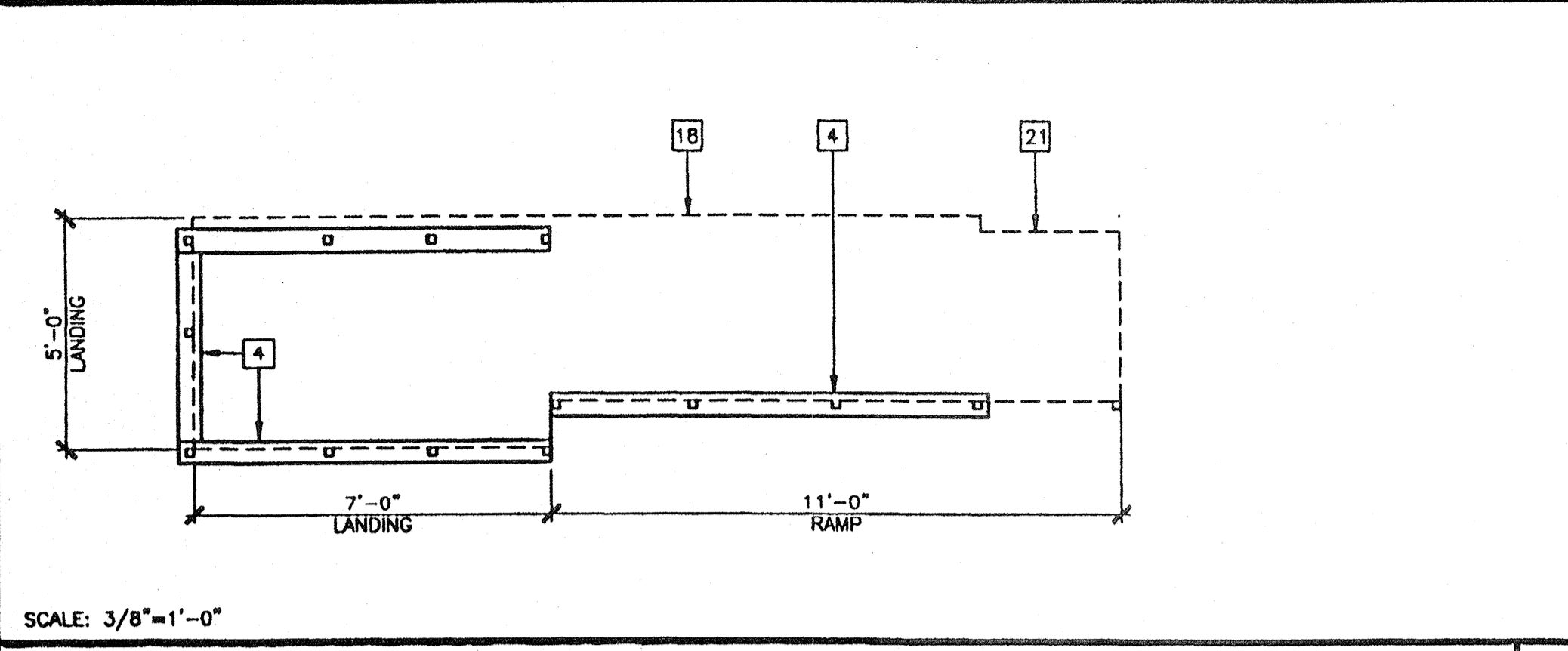

SCALE: 3/8"=1'-0"

SILL PLAN FOR RAMP AND LANDING 1

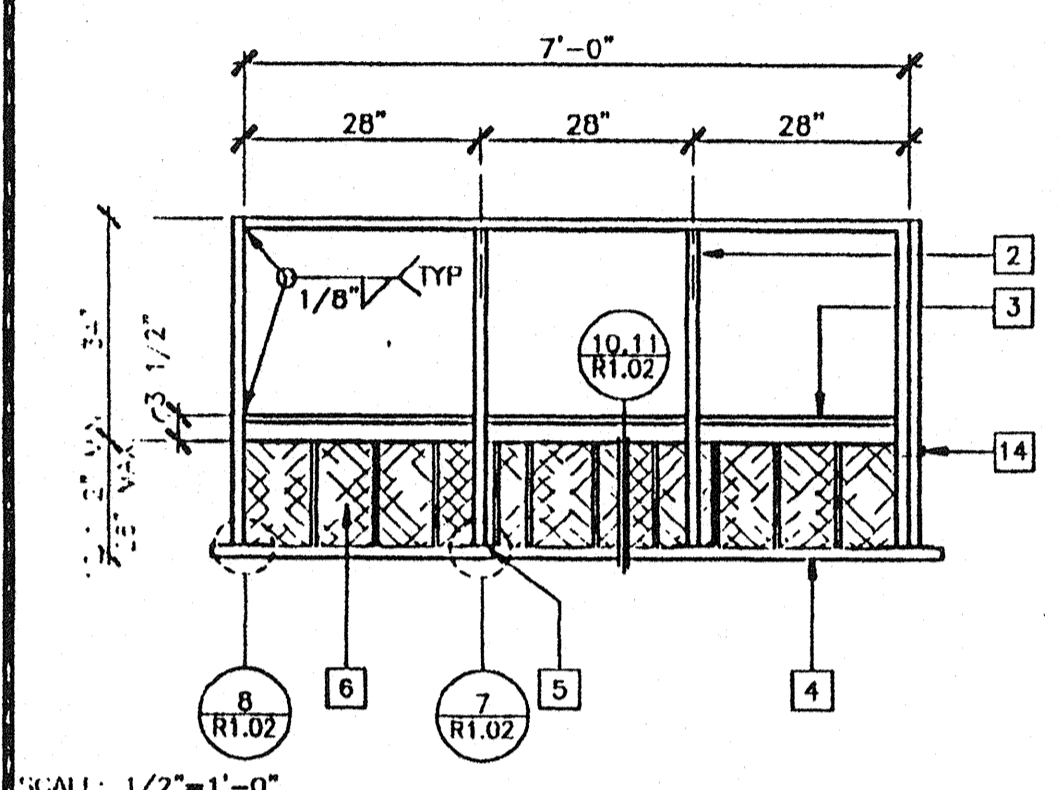

SCALE: 1/2"=1'-0"

LANDING ELEVATION 13

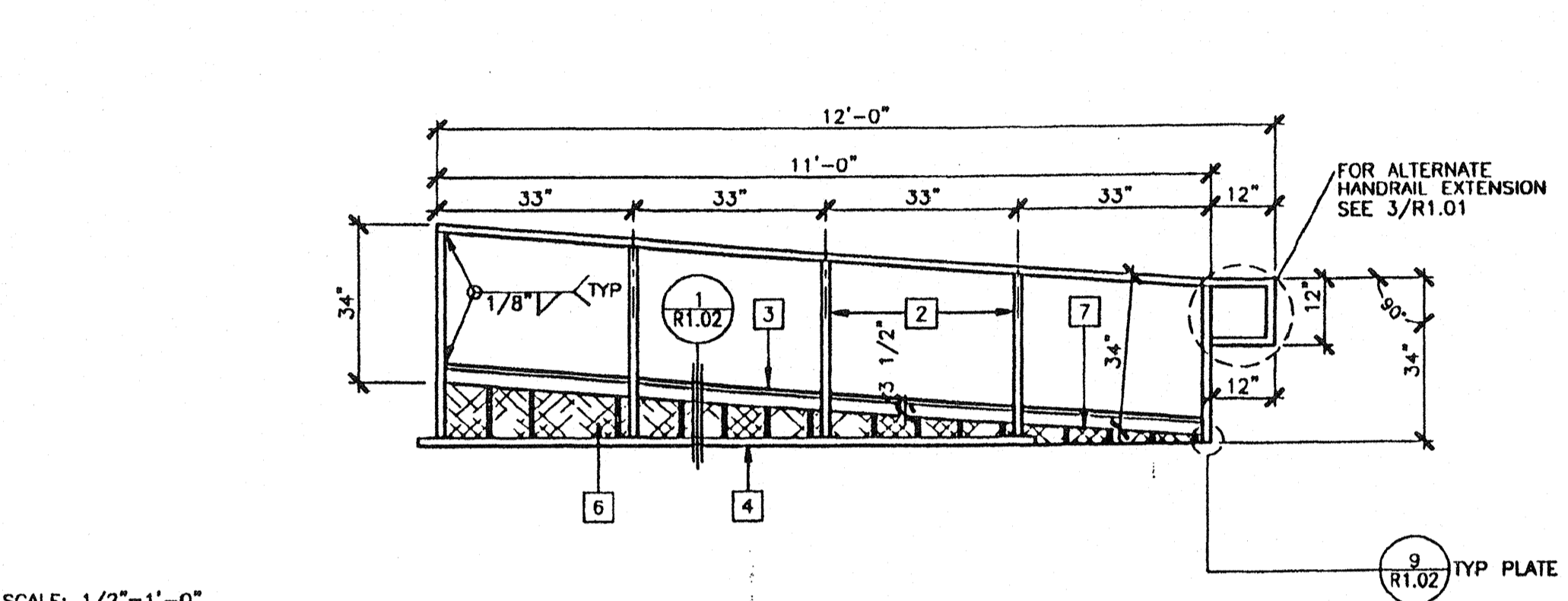

SCALE: 1/2"=1'-0"

RAMP ELEVATION 8

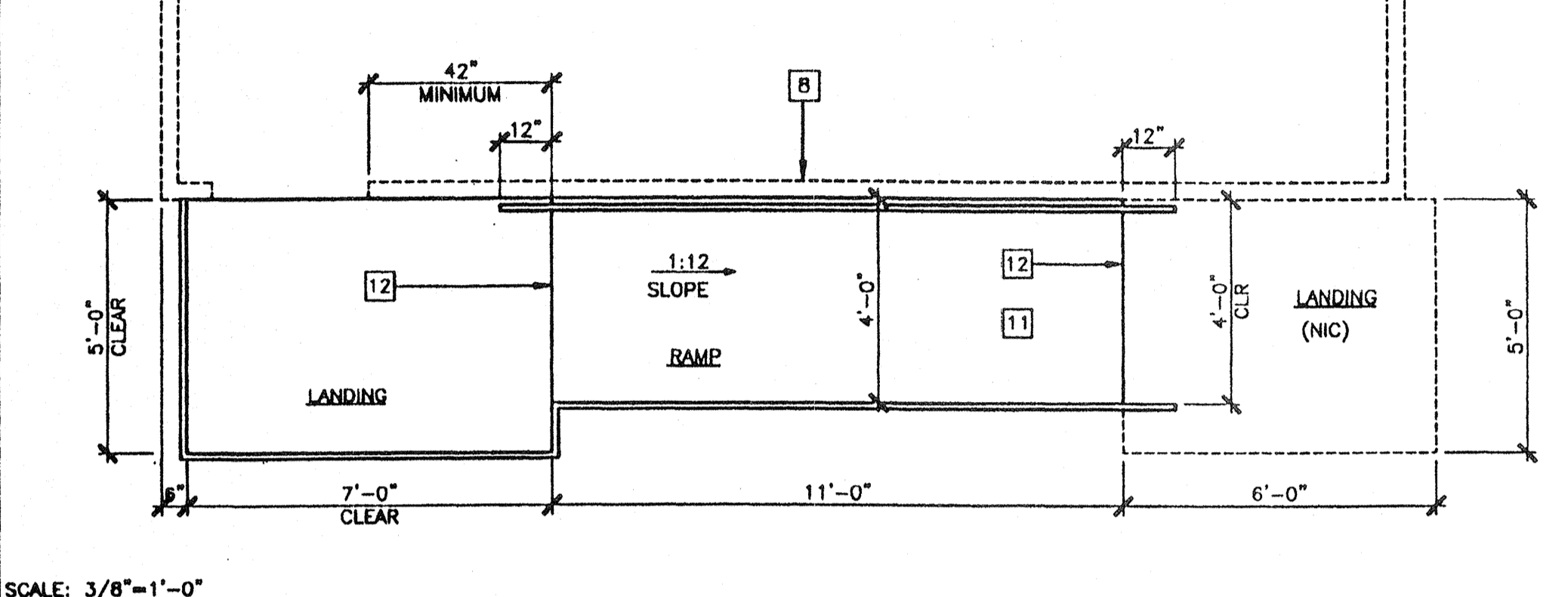

SCALE: 3/8"=1'-0"

RAMP AND LANDING AT BUILDING 2

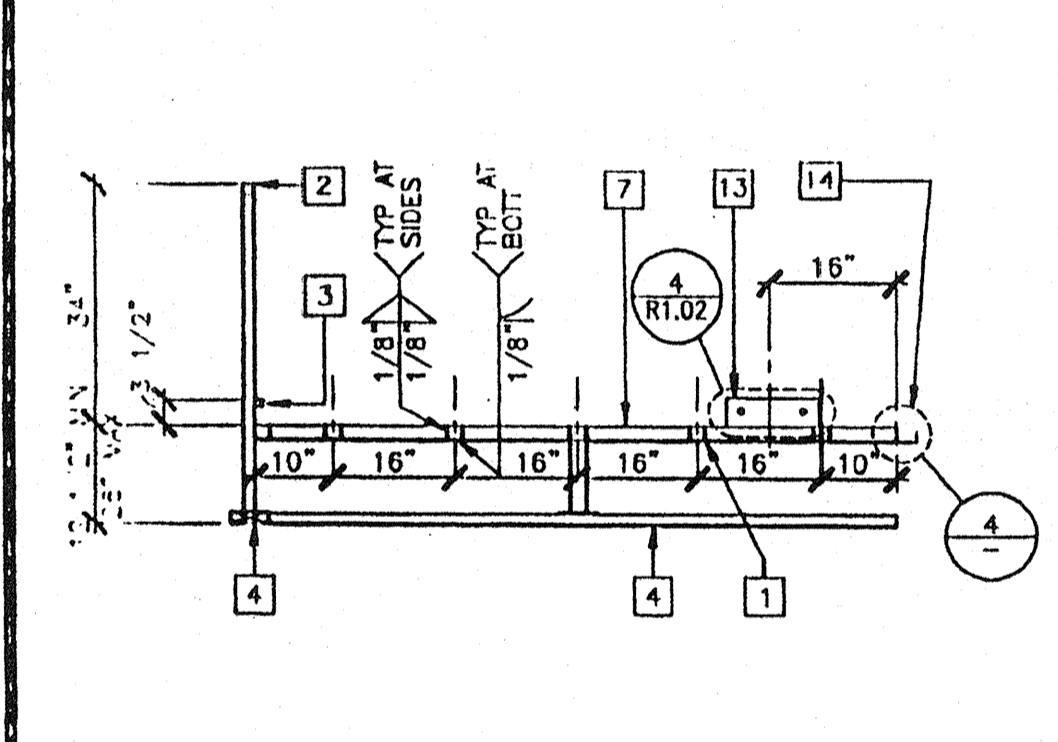

SCALE: NTS

SECTION AT LANDING 14

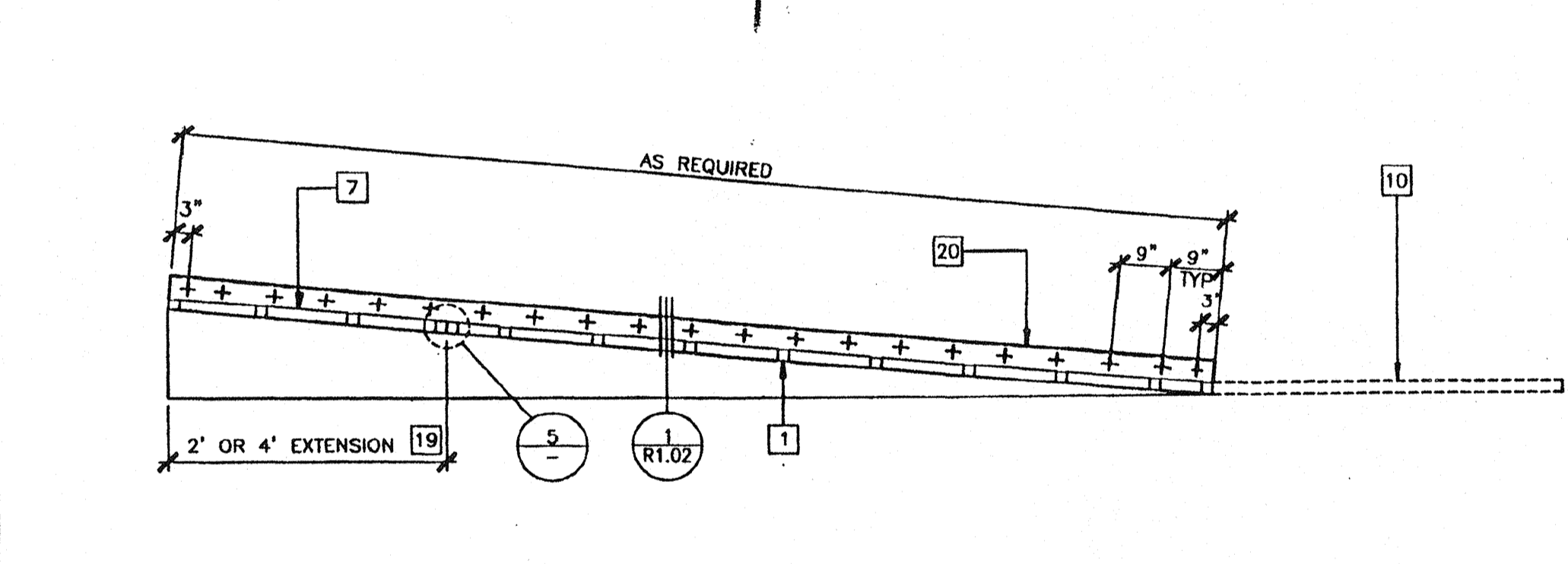

SCALE: NTS

LONGITUDINAL SECTION AT RAMP 9

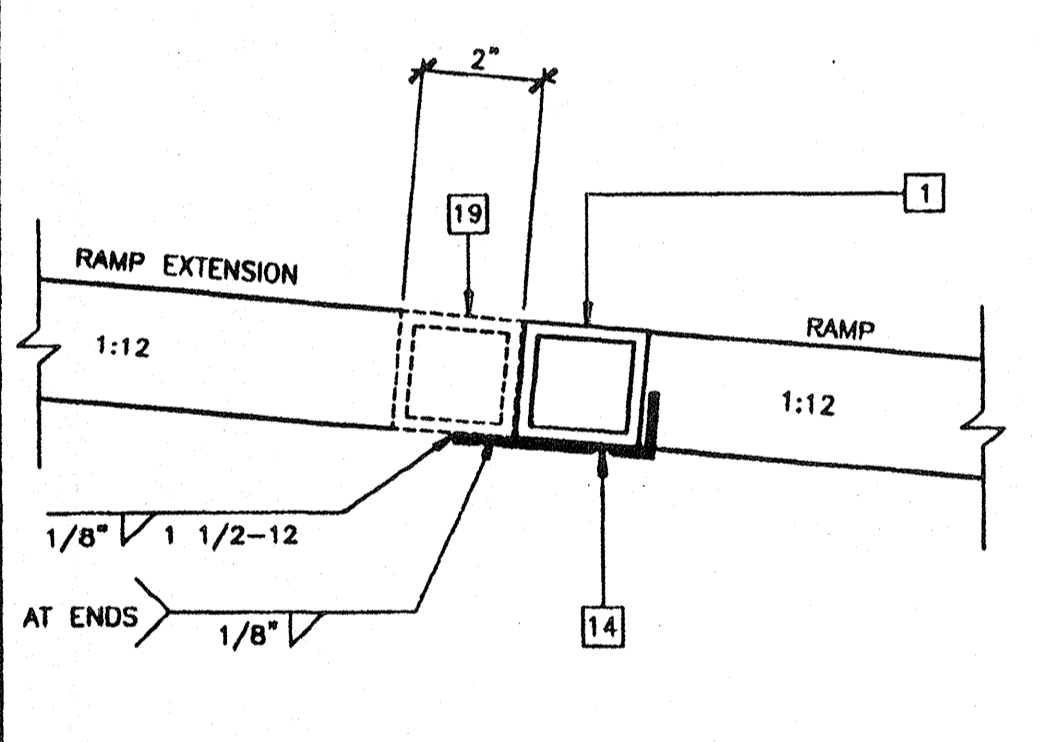

SCALE: NTS

RAMP EXTENSION TO RAMP 5

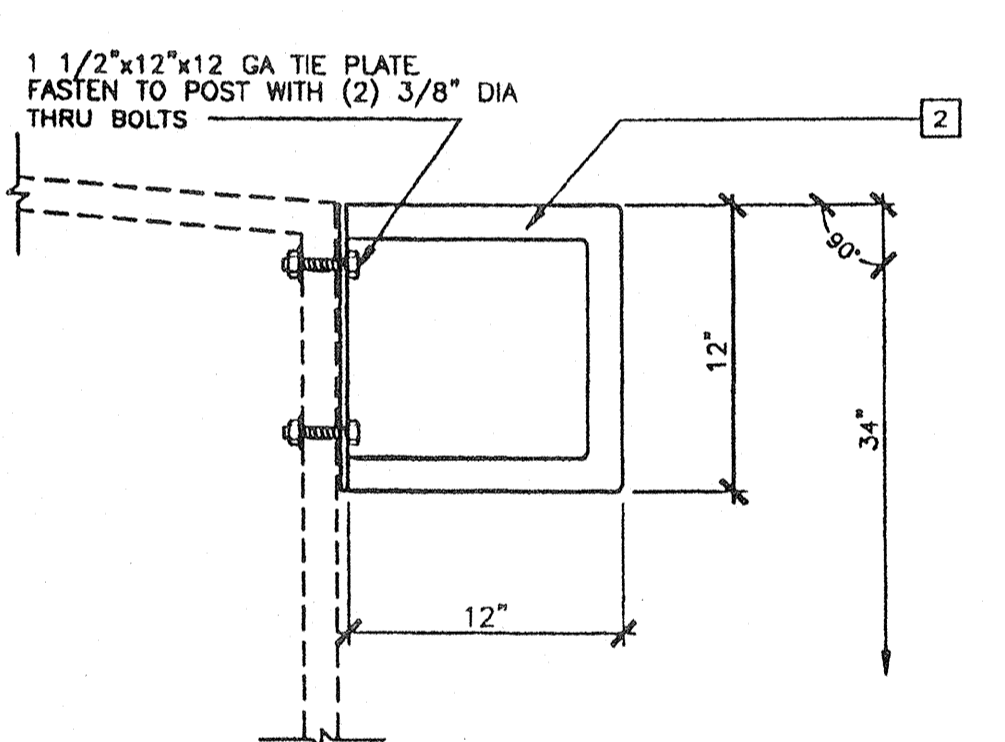

SCALE: NTS

ALTERNATE GUARD RAIL EXTENSION 3

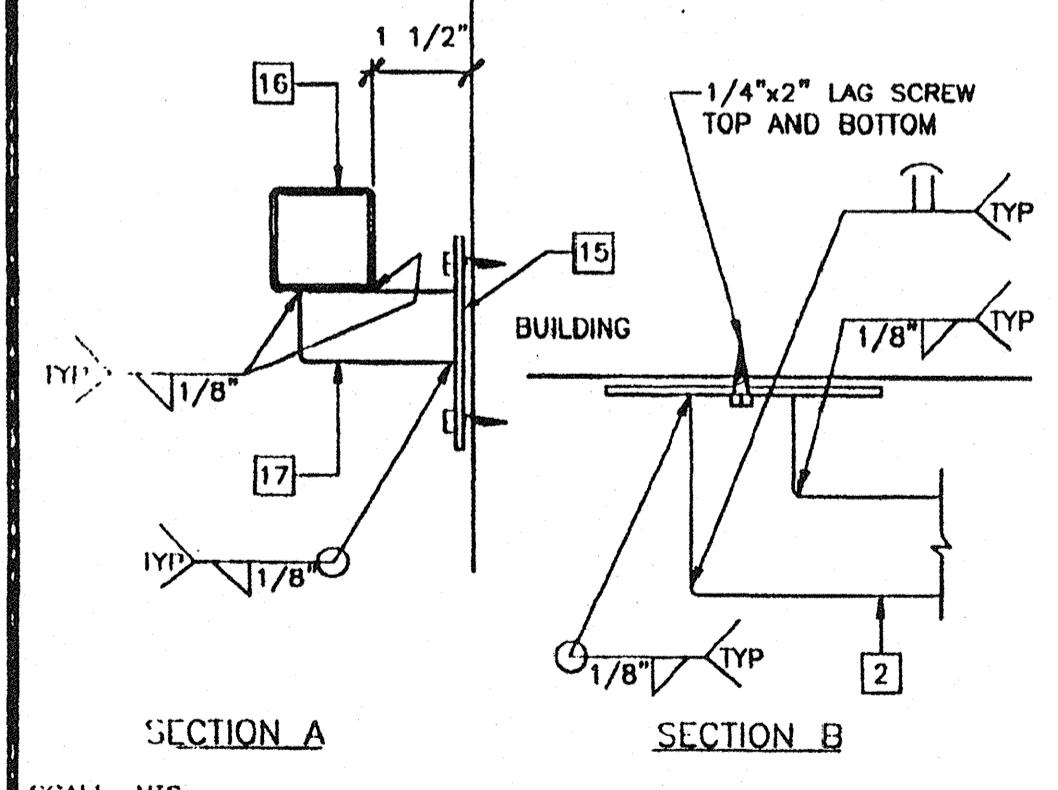

SCALE: NTS

HANDRAIL CONNECTION 15

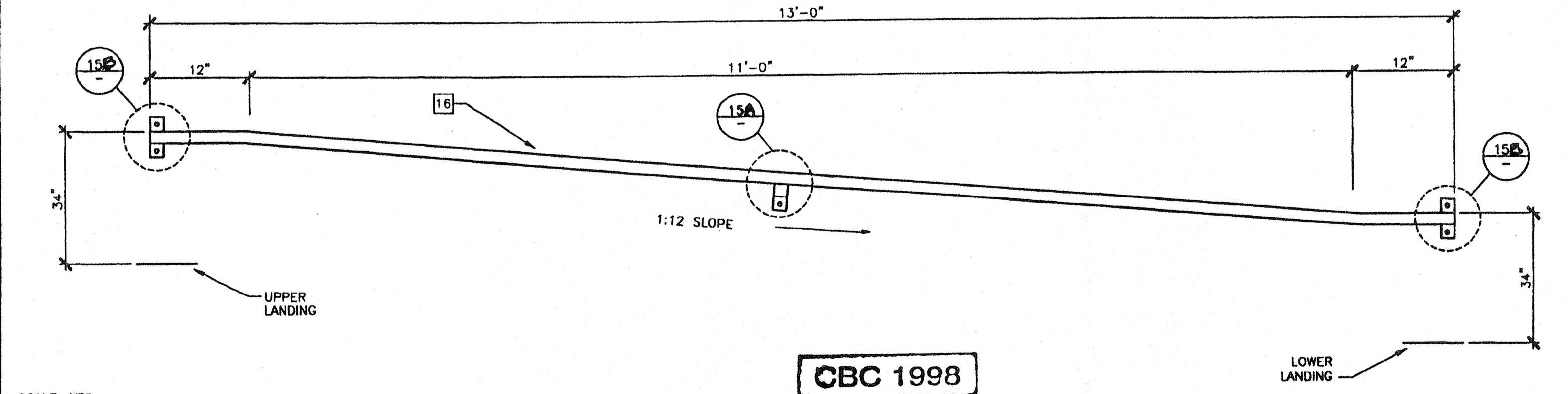

SCALE: NTS

HANDRAIL ATTACHED TO BUILDING (OPTIONAL) 6

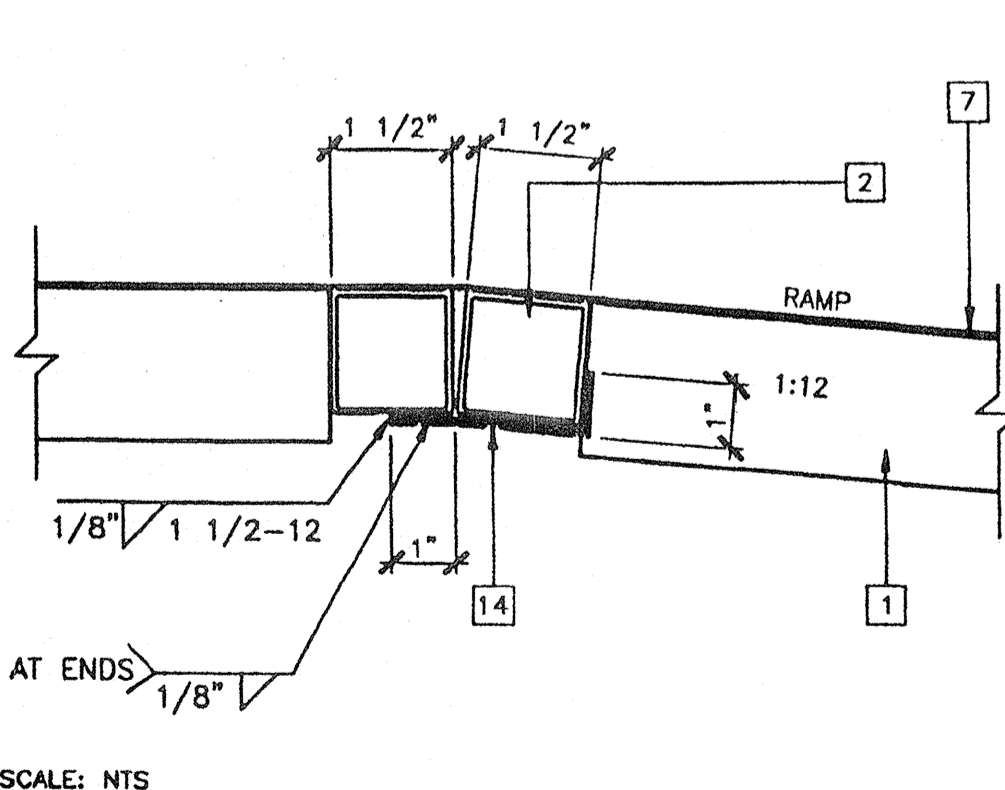

SCALE: NTS

RAMP AT LANDING 4

- KEY NOTES**
- 1 TS 2"x2"x14 GA
  - 2 TS 1 1/2"x1 1/2"x14 GA (Fy = 39KSI). ROUNDED OR BEVELLED AT CORNERS
  - 3 TS 1"x1"x16 GA WITH CHAIR GUILD
  - 4 2"x6" PRESSURE TREATED SILL PLATE
  - 5 2"x4"x12 GA BASE PLATE WITH (2) 1/4"x1" LAGS
  - 6 SKIRTING: PLYWOOD TO MATCH BUILDING SIDING. BLOCK ALL EDGES. ATTACH WITH #8 AT 6" OC EDGES AND 12" OC FIELD. AT EDGE CONNECTION TO TUBE STEEL USE #14x2" TEK SCREWS AT 6" OC
  - 7 12 GA METAL DECK: NON-SLIP SURFACE. DESIGN COEFFICIENT OF FRICTION GREATER THAN 6%. MAINTAINABLE FOR 1 YEAR EXISTING BUILDING
  - 8 6"x10"x12 GA BASE PLATE AT RAMP TOI
  - 9 LOWER LANDING BY DISTRICT
  - 10 RAMP BY MODTECH
  - 11 FLUSH TRANSITION
  - 12 6"x12"x10 GA PLATE WITH (2) 1/4"x3" LAGS TO STRUCTURAL FRAME OF BUILDING
  - 13 3"x1"x3'-0"x10 GA BENT PLATE
  - 14 2"x4"x 1/8" PLATE
  - 15 TS 1 1/2"x1 1/2"x14 GA HANDRAIL - CONTINUOUS AND UNINTERRUPTED. ROUNDED OR BEVELLED AT CORNERS
  - 16 TS 1"x1"x16 GA RAIL SUPPORT
  - 17 LINE OF RAMP/LANDING ABOVE
  - 18 RAMP EXTENSION FRAME
  - 19 6"x10 GA CONTINUOUS PLATE WITH 1/4"x2" ILK SCREWS AT 9" OC INTO WOOD OR FOUNDATION BLOCKS OR #14x2" TEK SCREWS INTO STEEL AT 9" OC
  - 20 NOTCH BOTTOM PLATE (MUD SILL) AS REQUIRED TO CLEAR RAMP TOE. MAX NOTCH 1 1/2"x4'-0" LONG.
  - 21 NOTCH BOTTOM PLATE (MUD SILL) AS REQUIRED TO CLEAR RAMP TOE. MAX NOTCH 1 1/2"x4'-0" LONG.
  - 22 LINE OF STAIR OPTION - 12,13/R1.02

**NOTES**

1. RAMPS: RAMPS SHALL NOT SLOPE MORE THAN 1" IN 12"
2. HANDRAILS: HANDRAILS AT BOTH SIDES OF RAMP AT 34" HIGH.
3. SURFACE: LANDING & RAMP TO HAVE NON-SLIP SURFACE AMCOR GRIP II AS MANUFACTURED BY AMERICAN CHEMICAL COMPANY (OR EQUAL)
4. GROUNDING: PROVIDE GROUNDING OF RAMP TO BUILDING FRAME WITH #8 COPPER TO BOTH GROUND LUGS.
5. ARCHITECT SITE/RAMP/LANDING PLANNING: DUE TO VARYING SITE CONDITIONS THE MAXIMUM HEIGHT OF FINISH FLOOR FROM GRADE IS 26". THEREFORE IT IS POSSIBLE THAT THE ACCESS RAMP ATTACHED TO THE BUILDING COULD BE 26'-0" AT A SLOPE OF 1:12. ARCHITECT MUST TAKE INTO ACCOUNT THAT THE RAMP SUPPLIED BY MODTECH INC. IS 11'-0" AT A SLOPE OF 1:12. THEREFORE THE ARCHITECT WILL HAVE TO DESIGN AND PROVIDE DETAILS OF RAMP EXTENSIONS AND BOTTOM LANDING DEPENDING ON PARTICULAR SITE CONDITIONS. IN NO WAY IS MODTECH INC RESPONSIBLE FOR ANY RAMP EXTENSION EXCEEDING THE ORIGINAL PLAN AS SHOWN ON THIS SHEET
6. ALL 1 1/4" AND 1 1/2" TUBE STEEL TO BE IN ASTM A500 GRADE A STEEL (Fy = 39 KSI)

**REVISIONS**

1		
2		
3		
4		

Electrical Engineer's Seal  
Mechanical Engineer's Seal  
Architect's Seal

**CBC 1998**

IDENTIFICATION STAMP  
DIV. OF THE STATE ARCHITECT  
OFFICE OF REGULATION SERVICES  
PC-04  
101419  
DATE OCT 25 1999

**MODTECH INC.**  
2830 BARRETT AVENUE  
PERRIS, CALIF. 92572  
PH (909) 943-4014  
FAX (909) 940-0427

PROJECT NUMBER: \_\_\_\_\_  
DATE: \_\_\_\_\_  
CHECKED BY: SS  
DATE: 10/22/99  
MODTECH Index No. \_\_\_\_\_

© MODTECH, INC. 1999

**RAMP/LANDING 11' RAMP**

**R1.00**

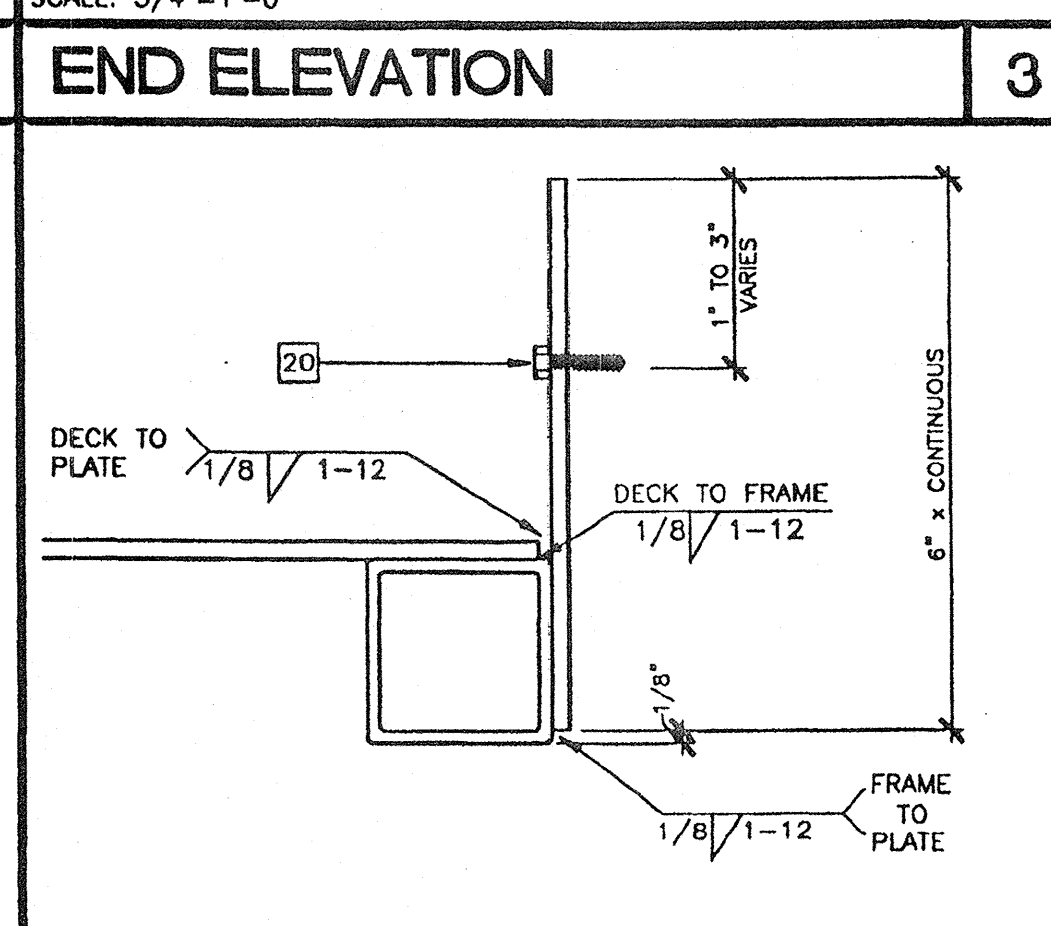
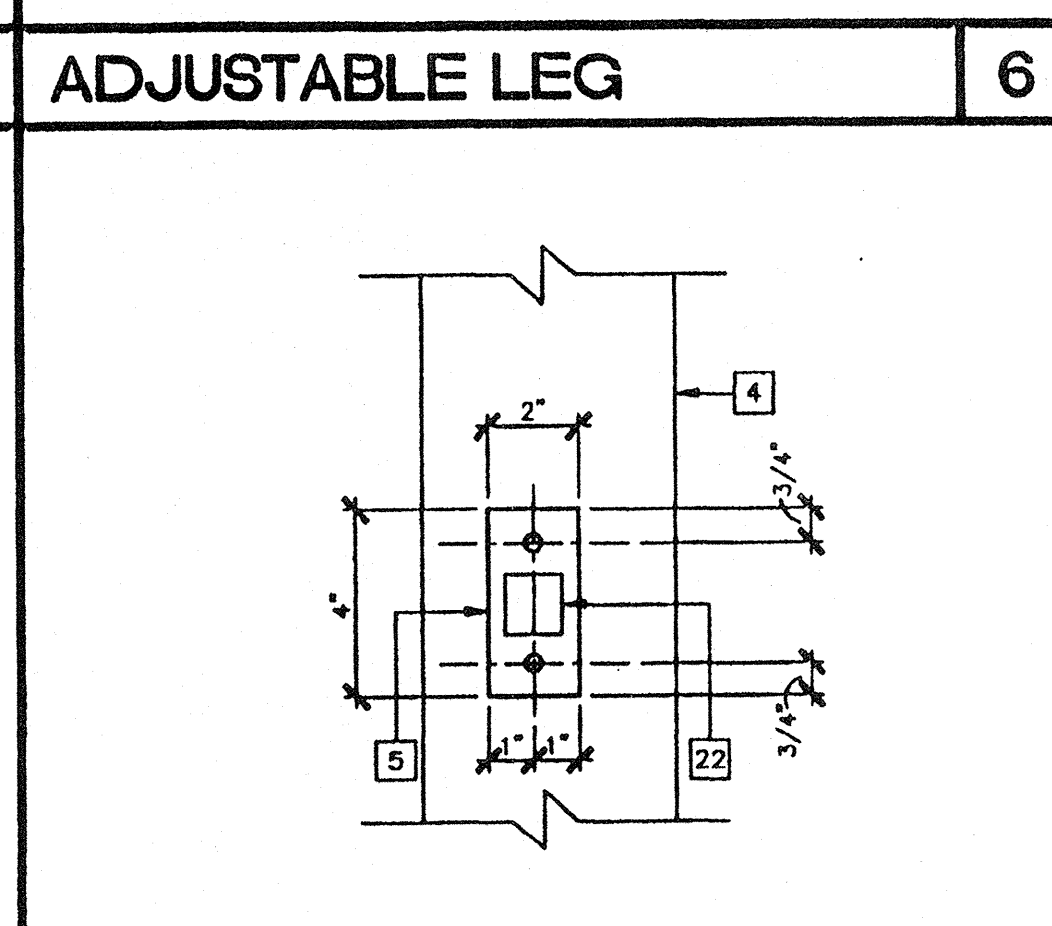
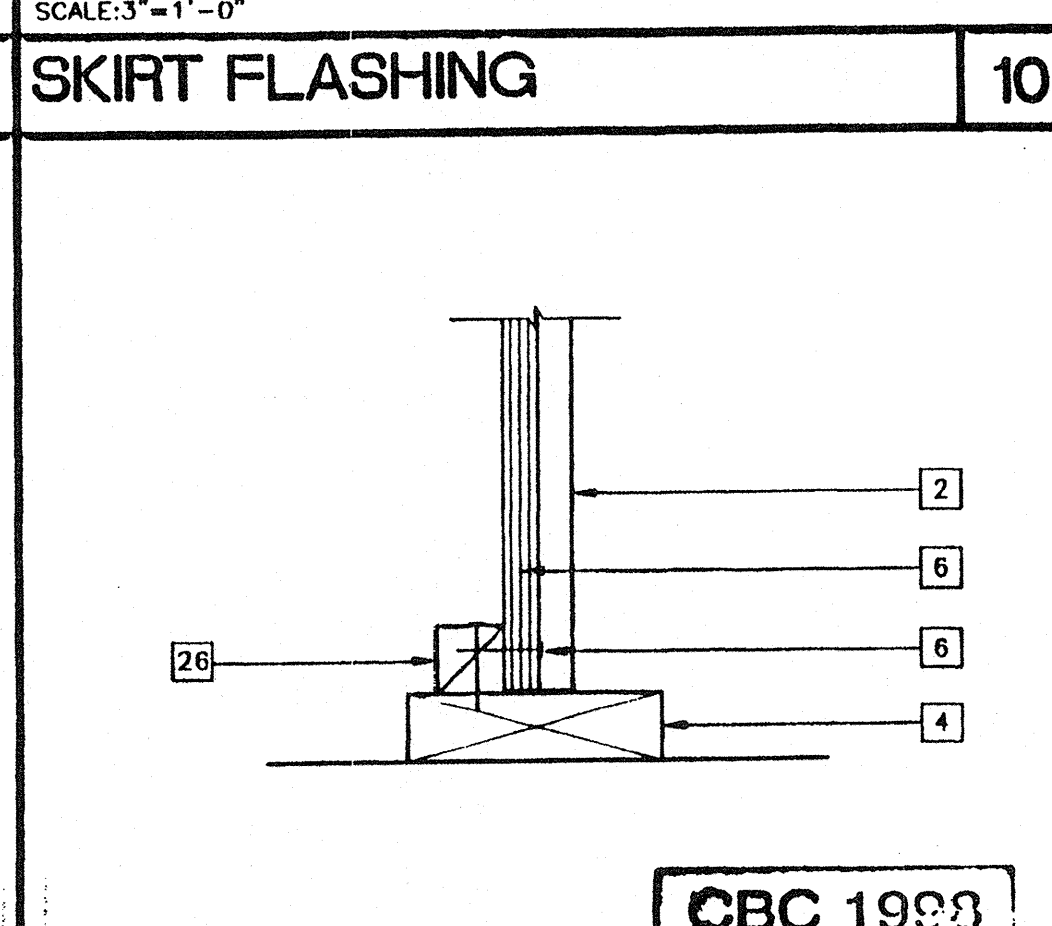
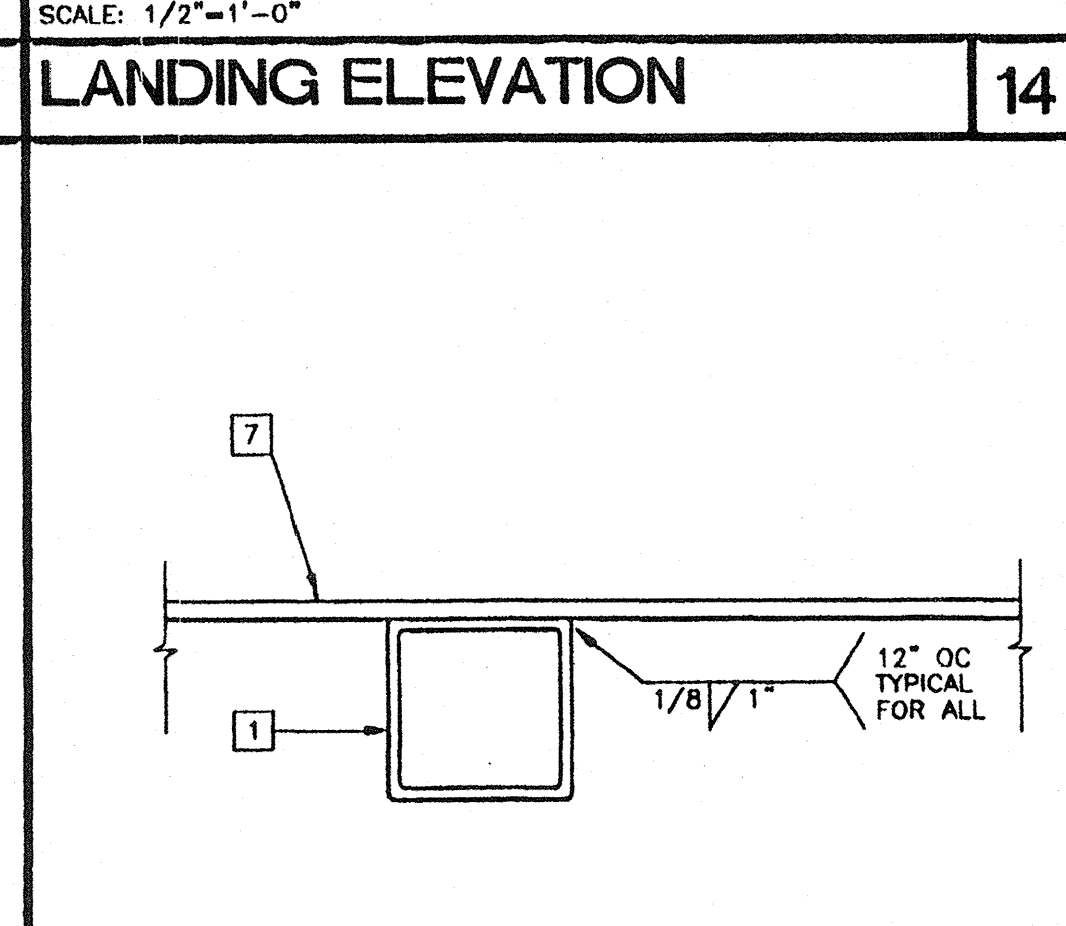
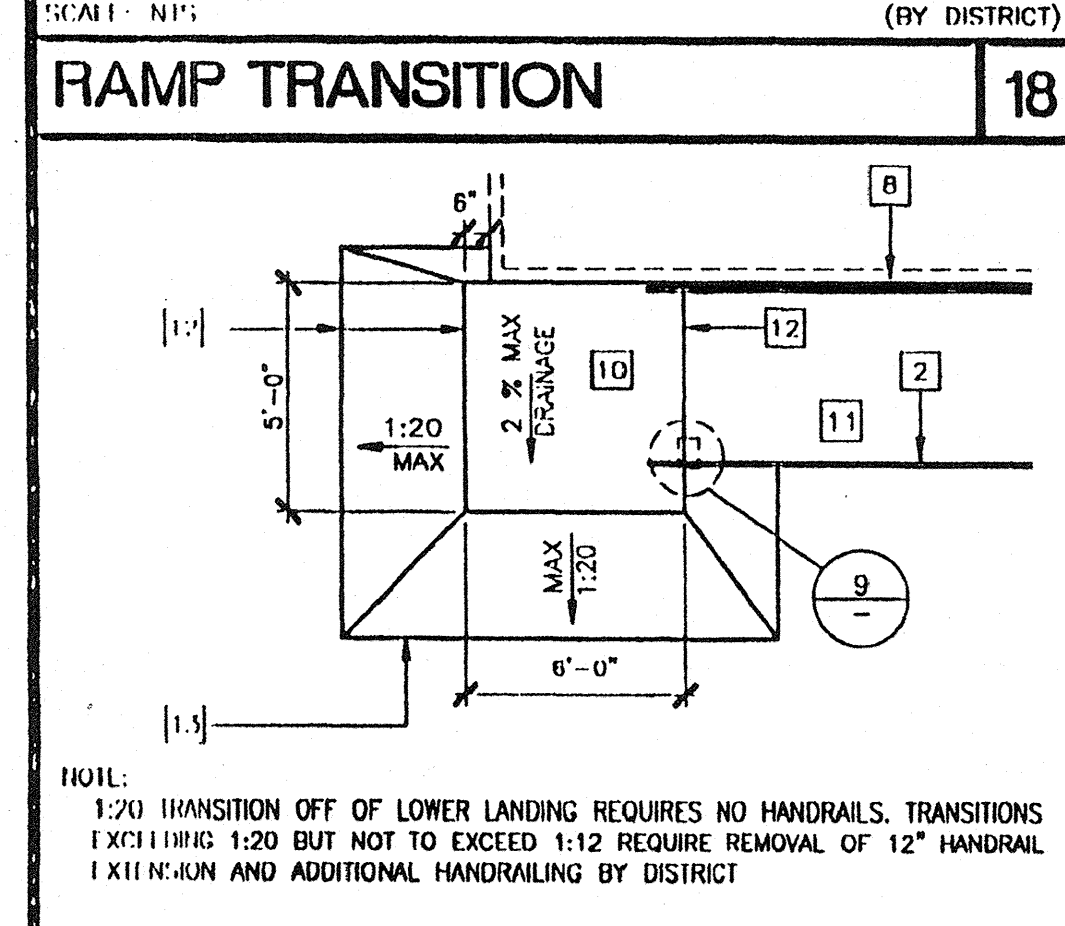
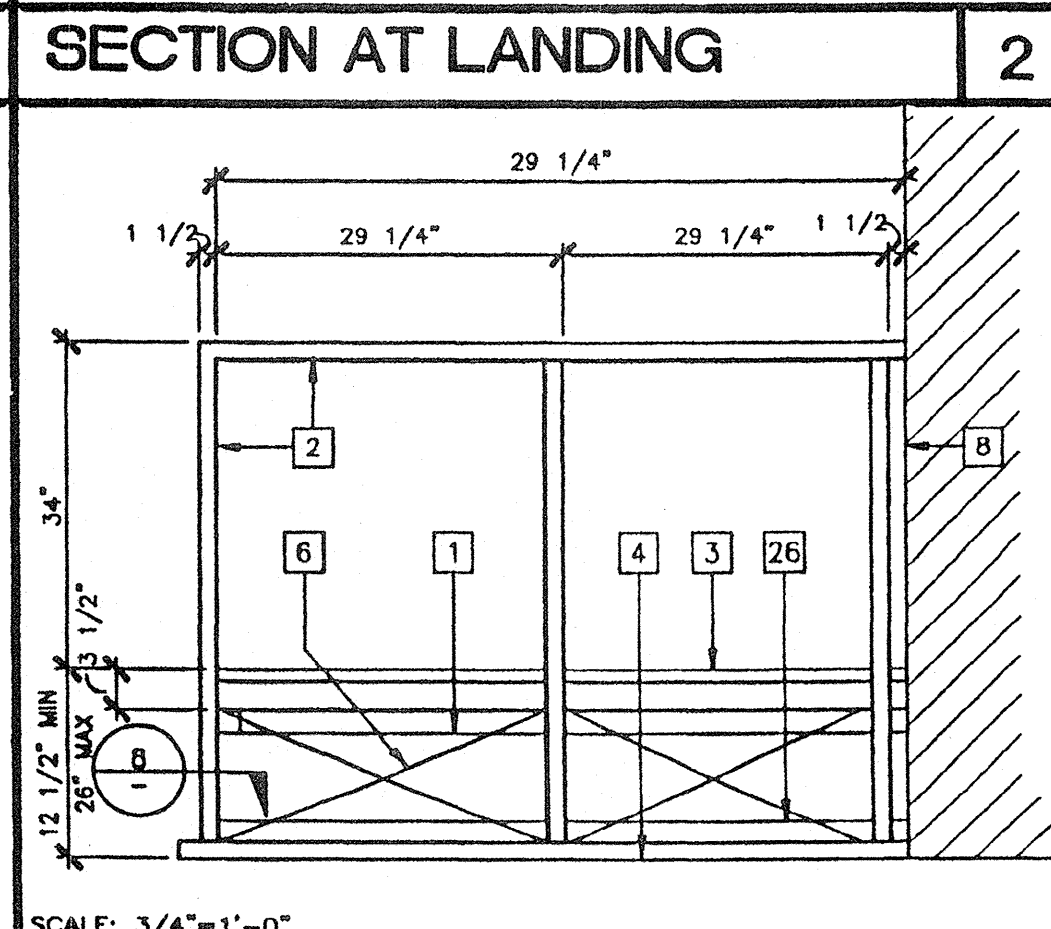
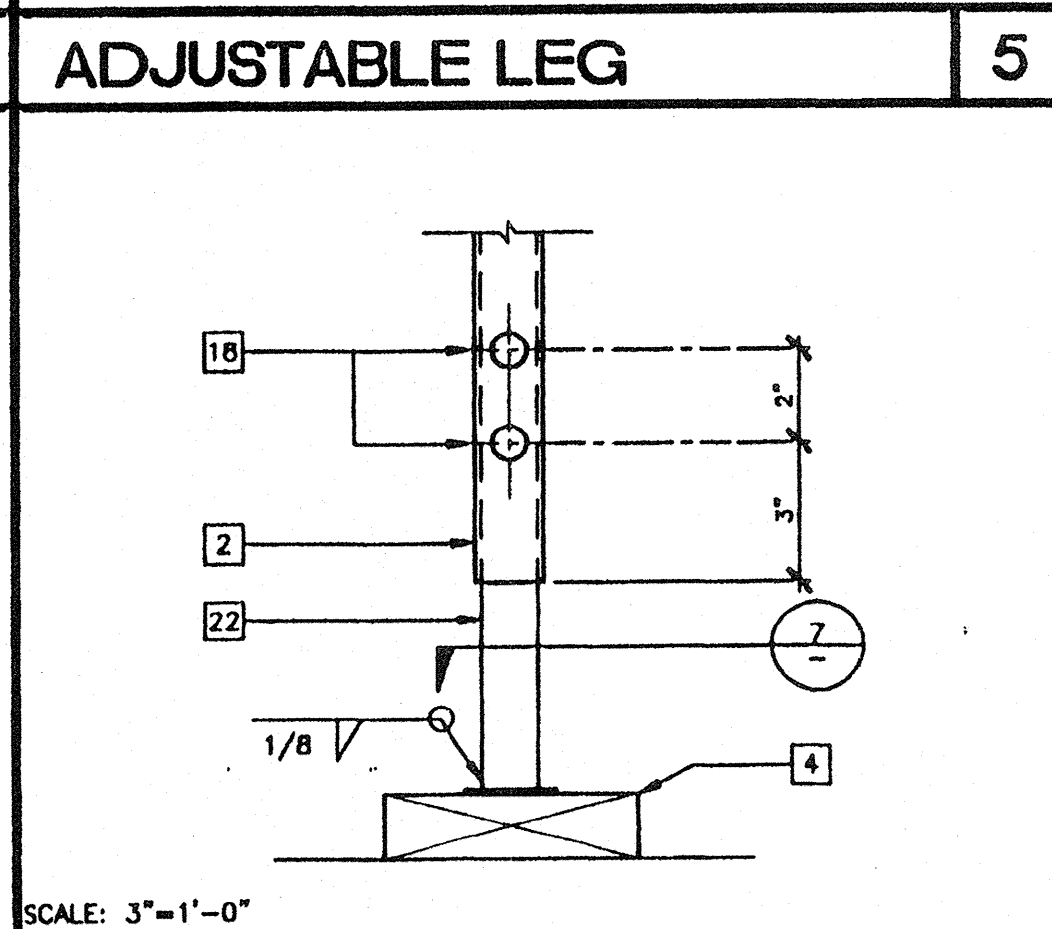
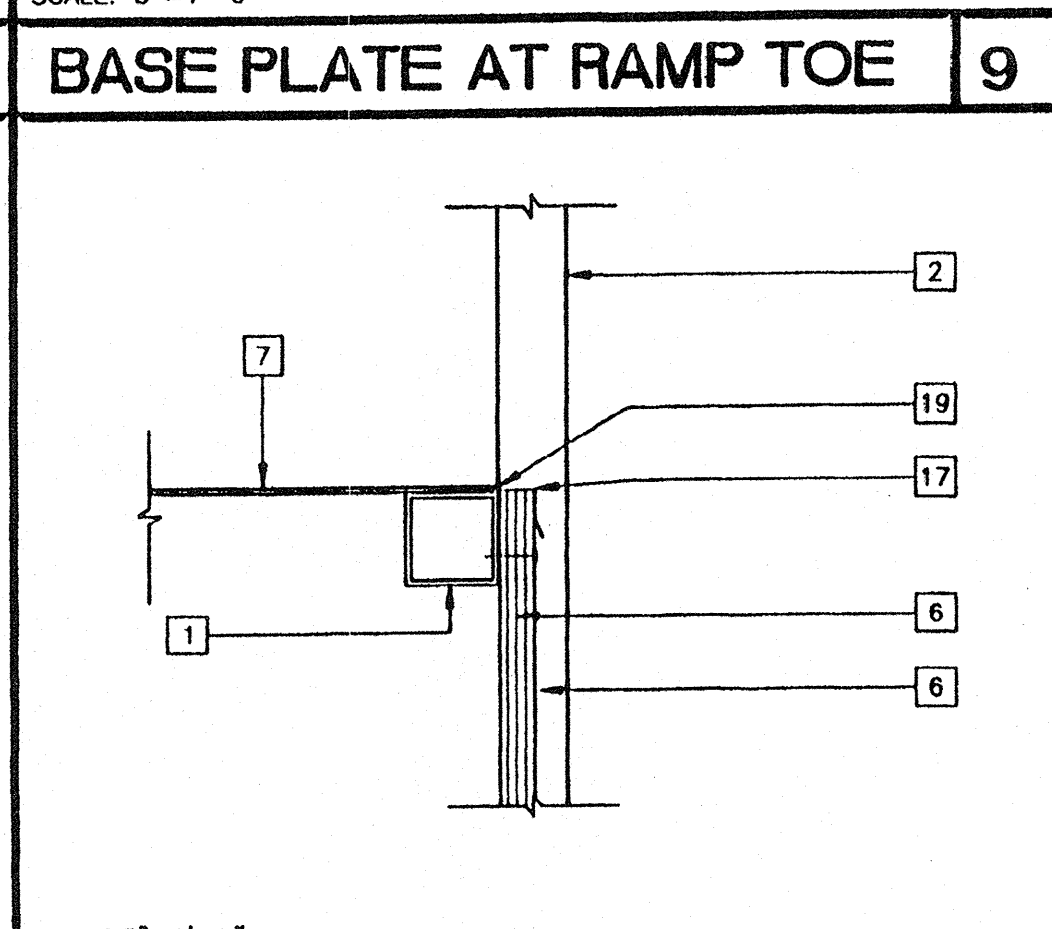
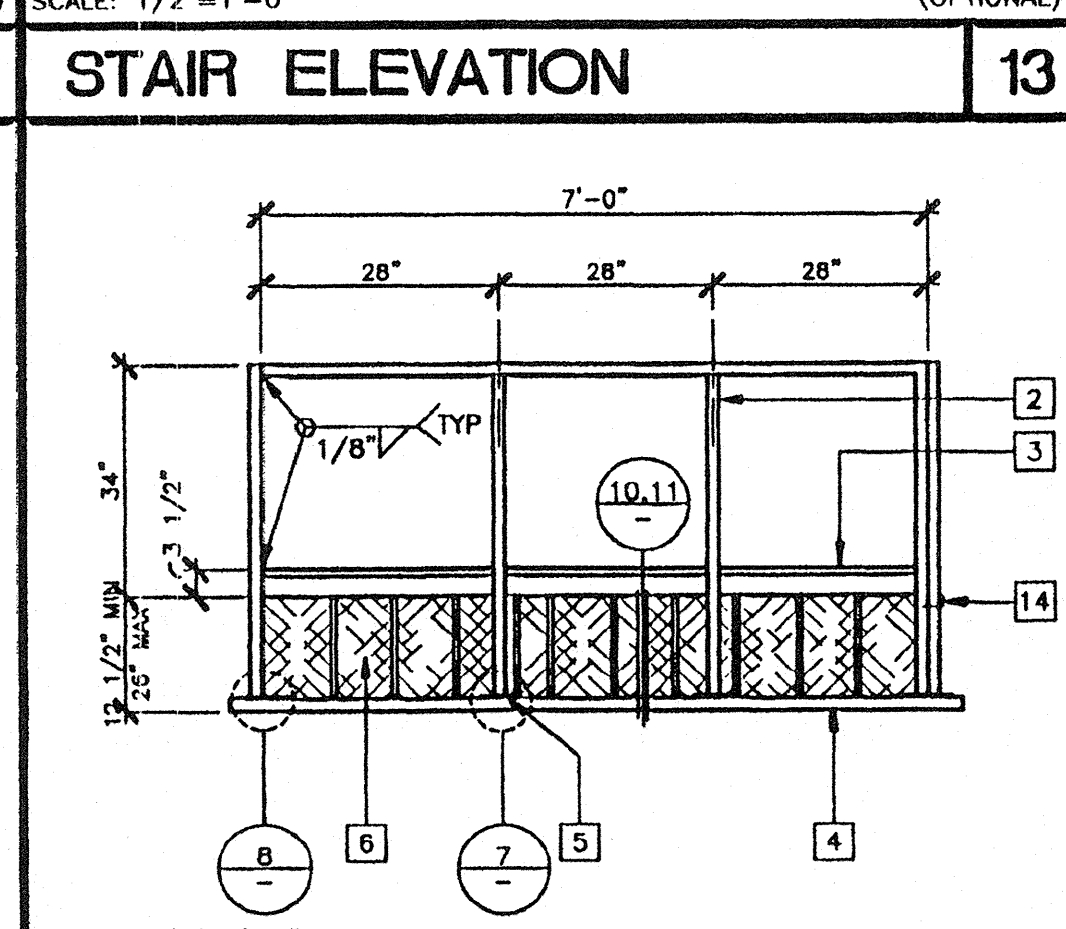
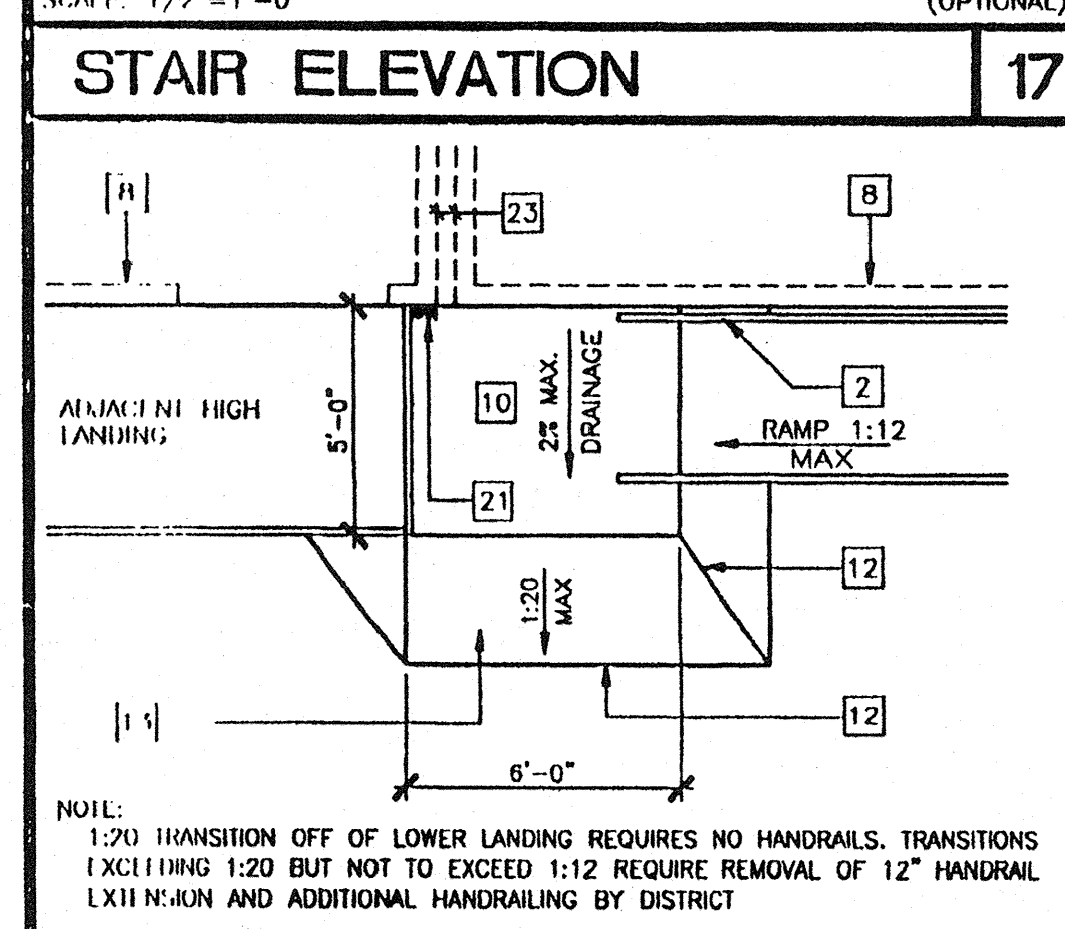
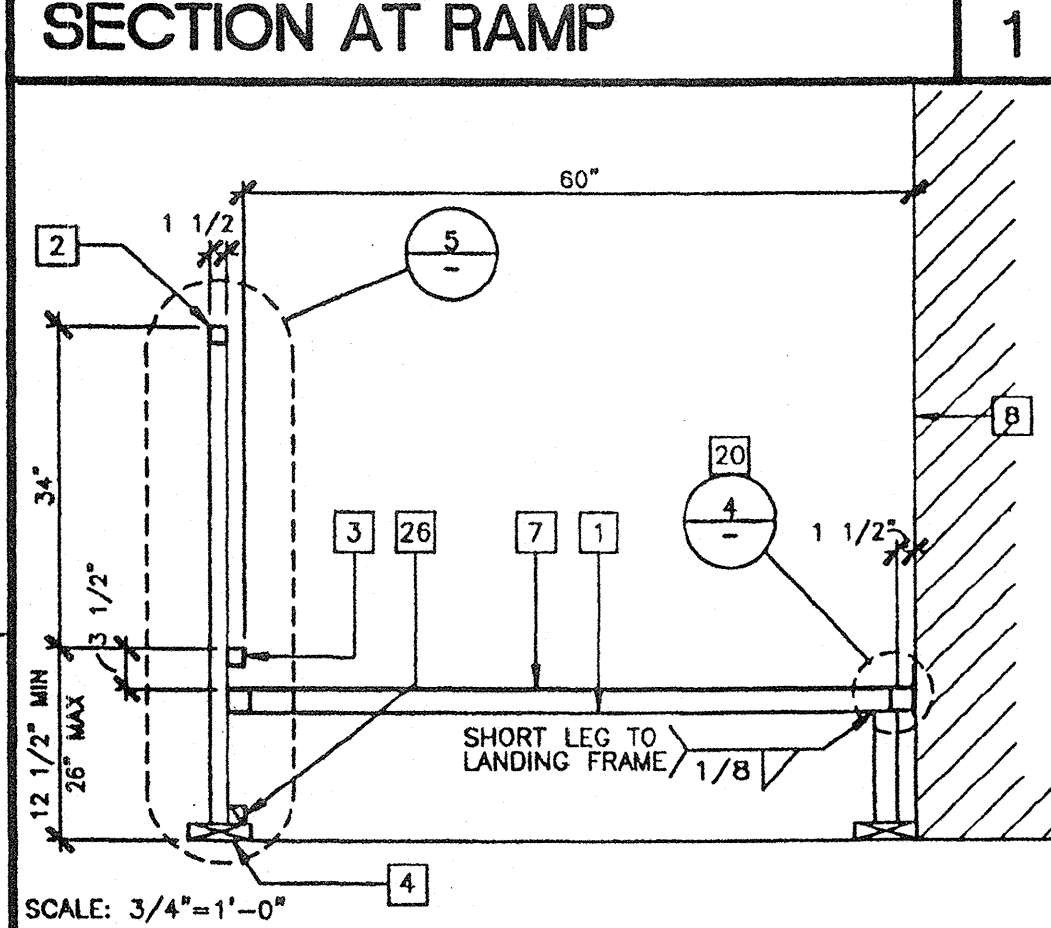
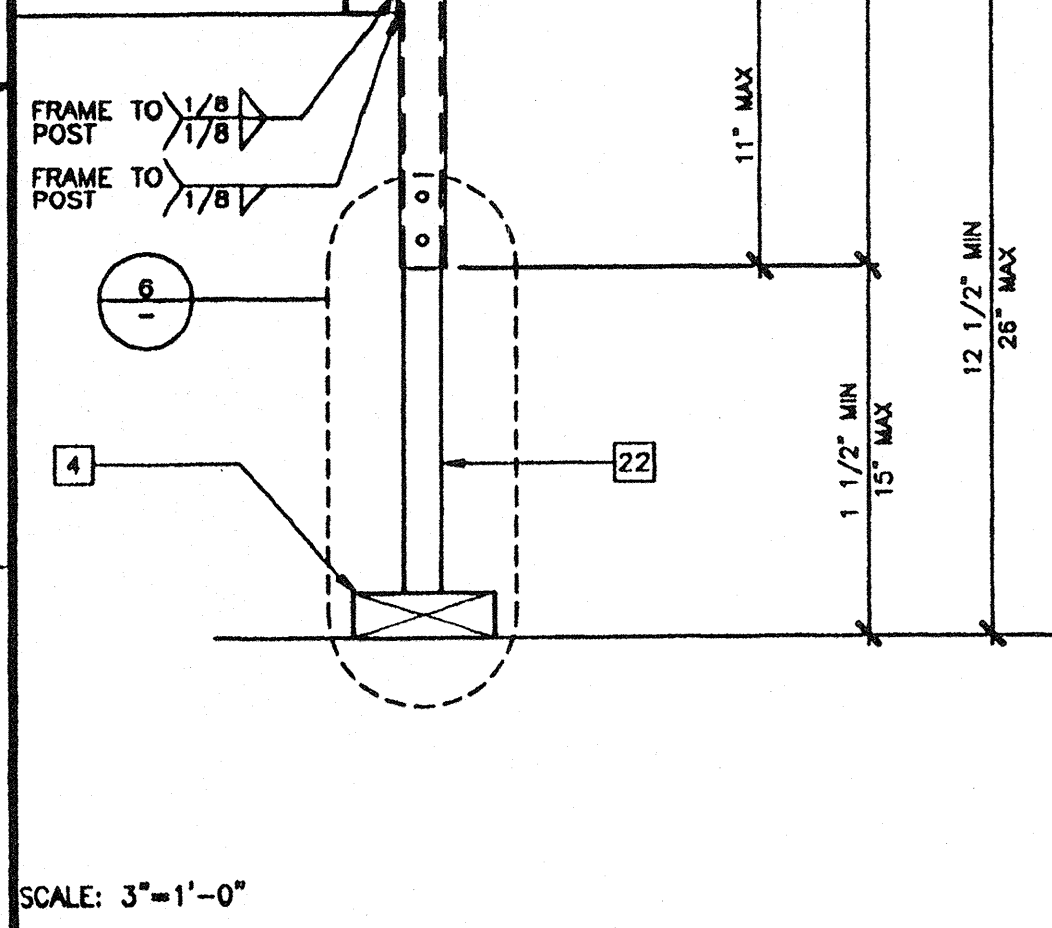
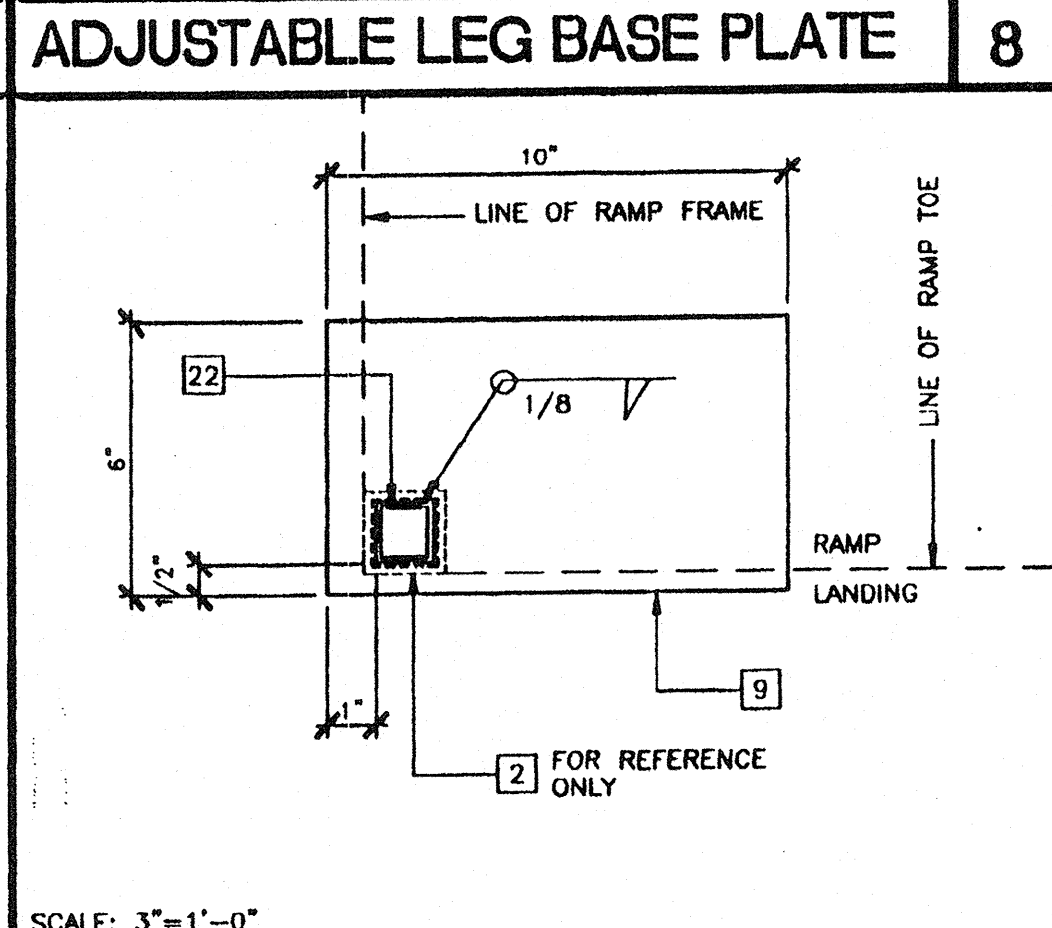
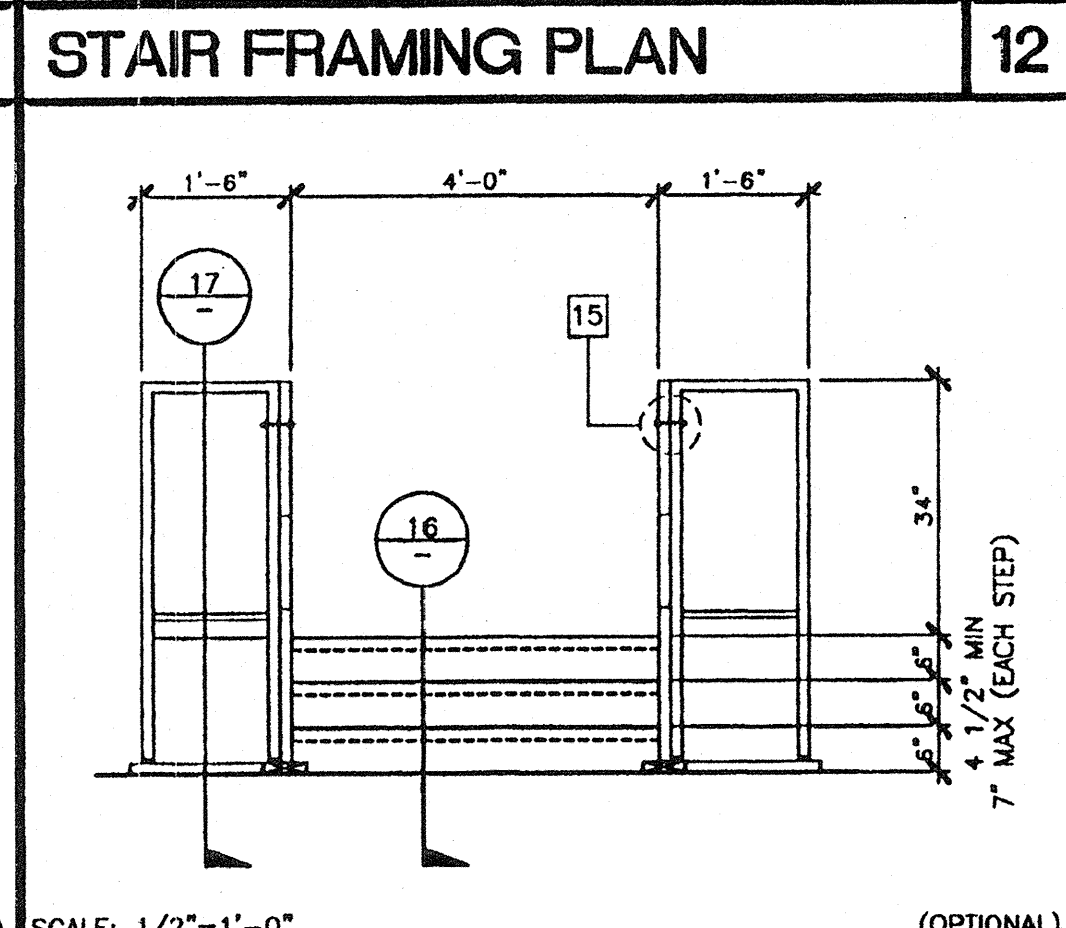
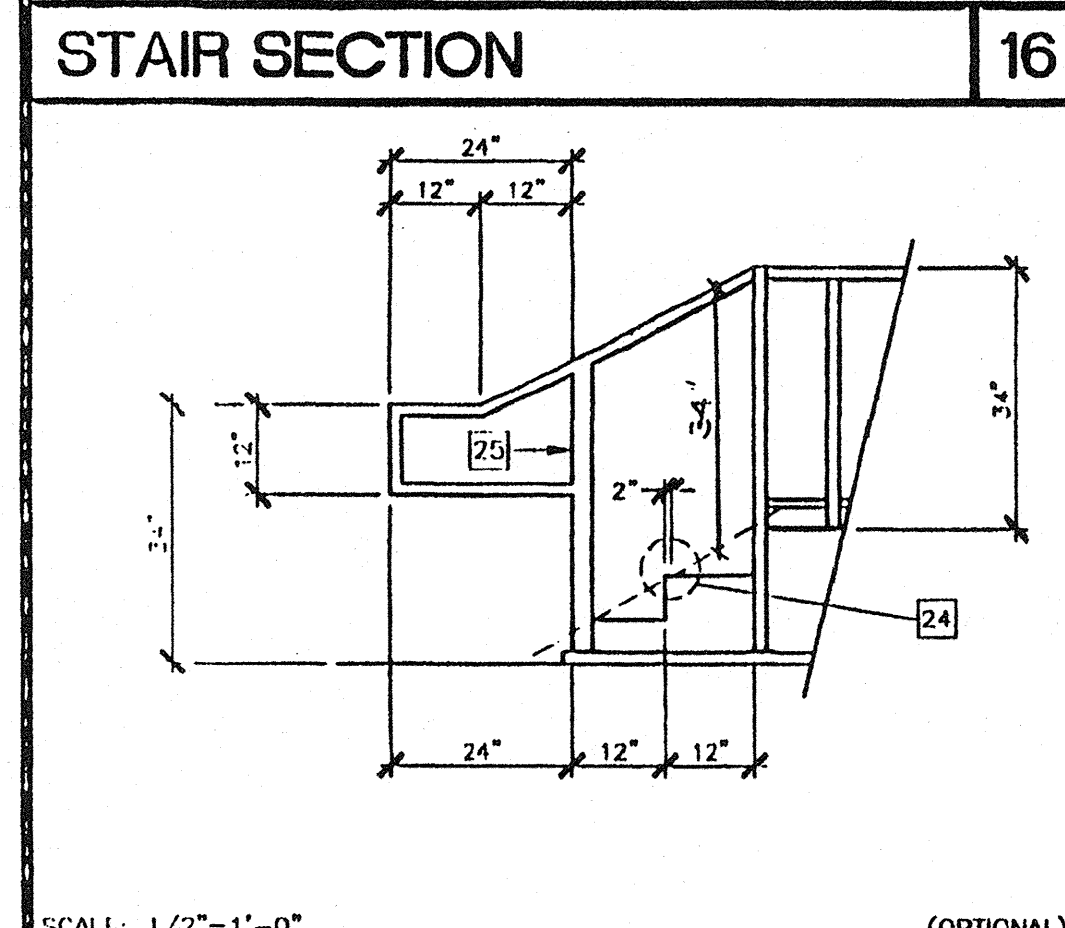
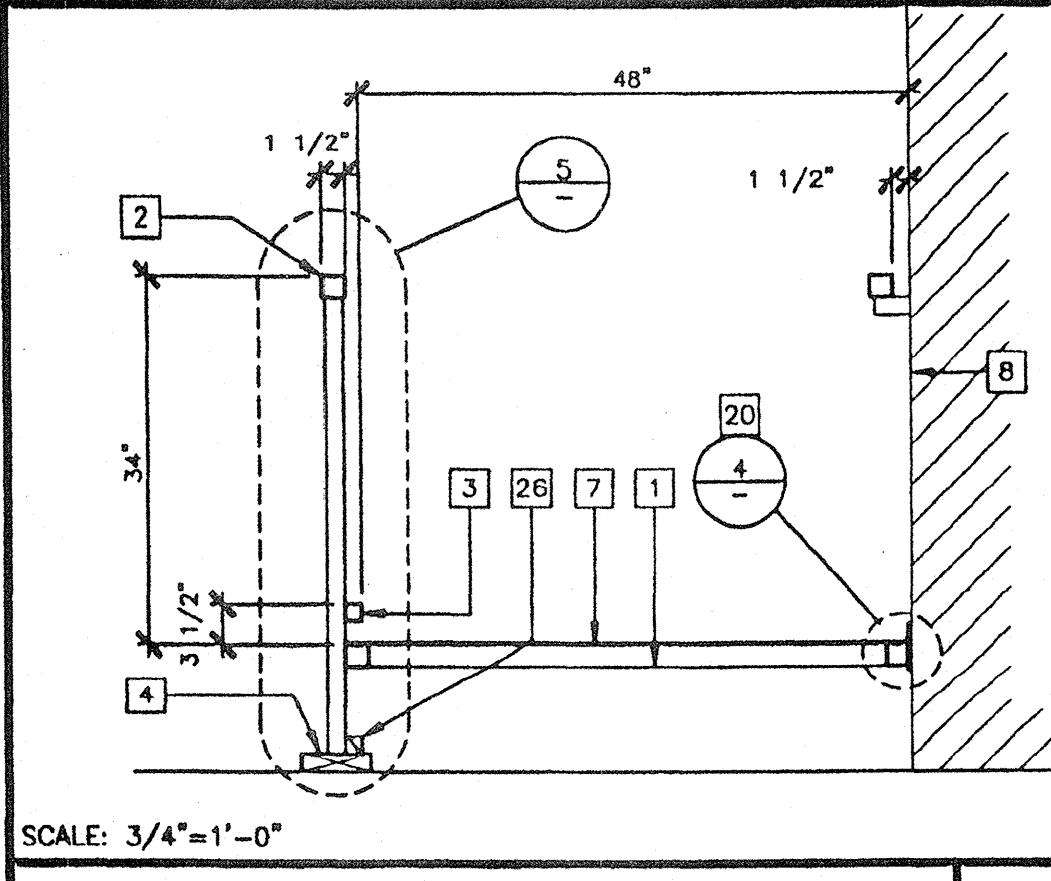
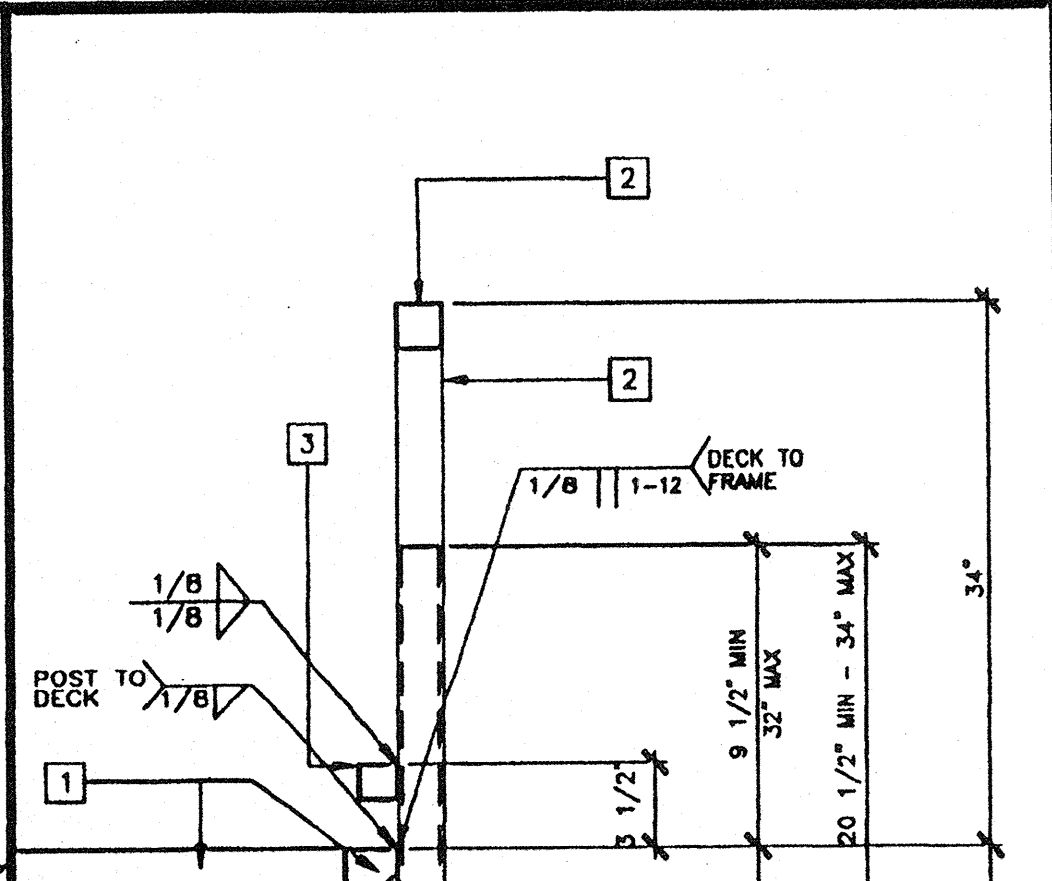
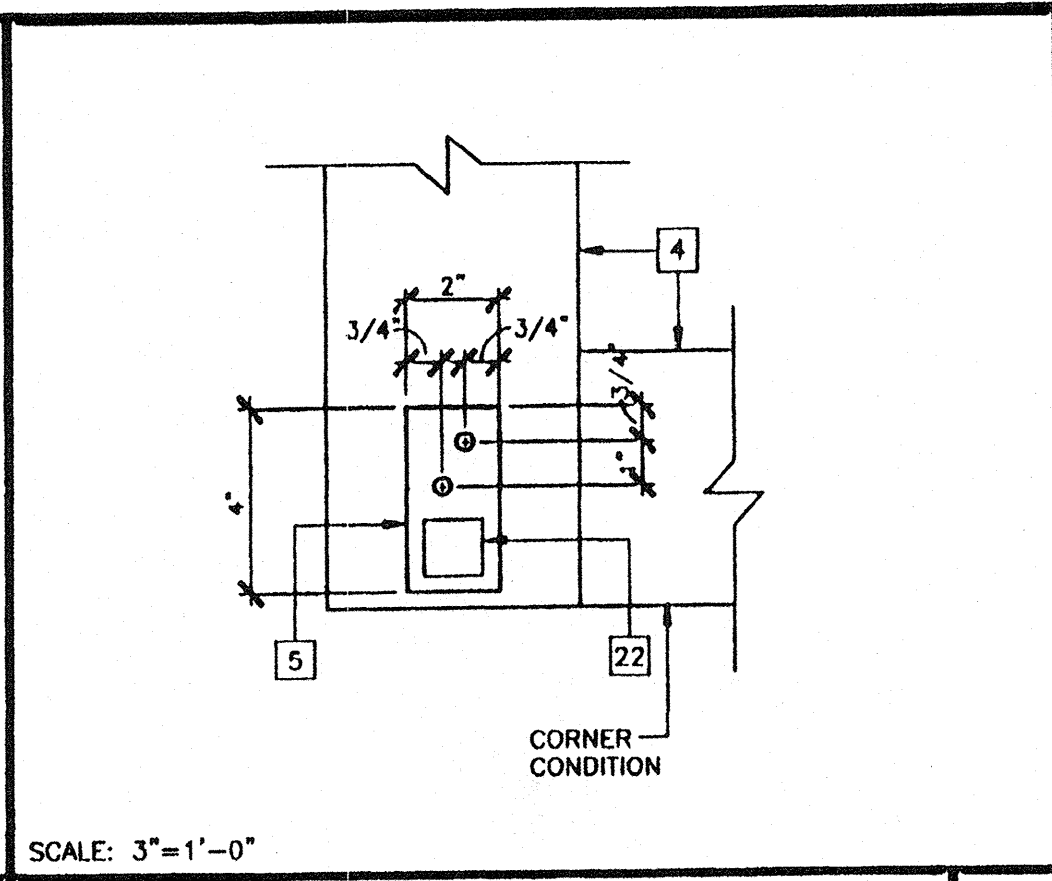
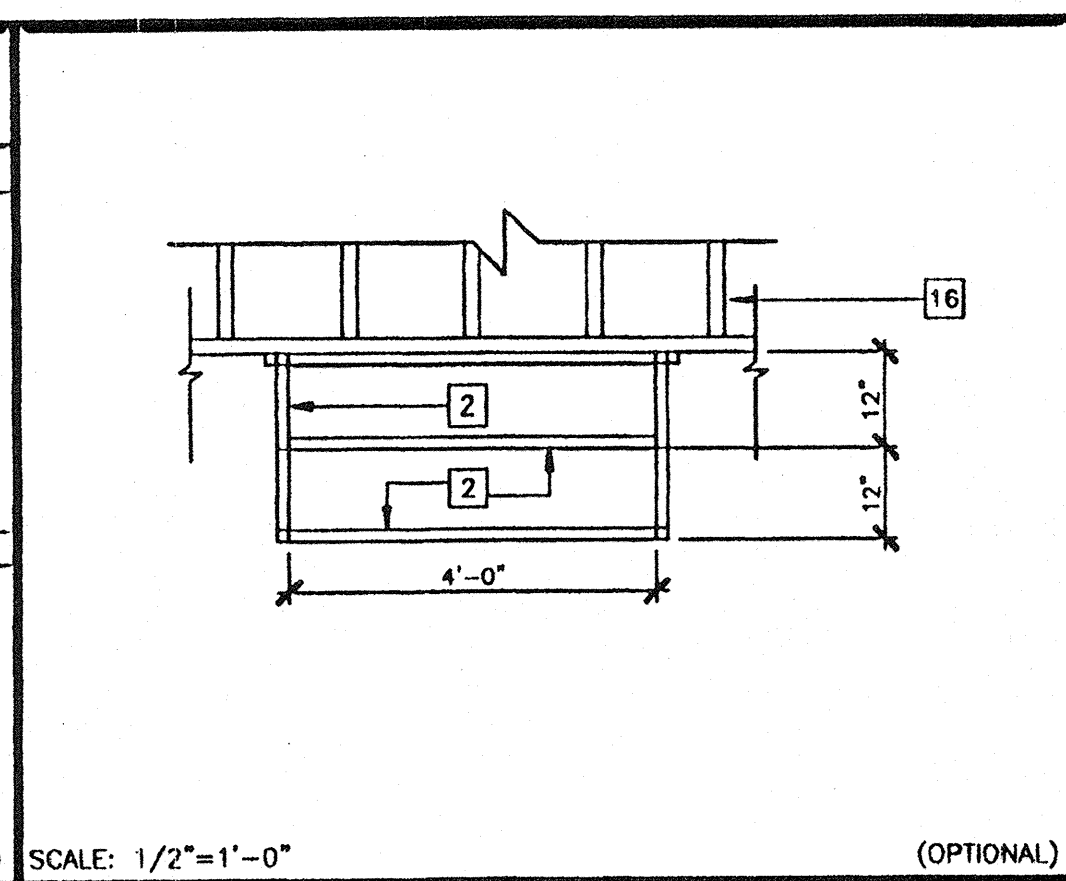
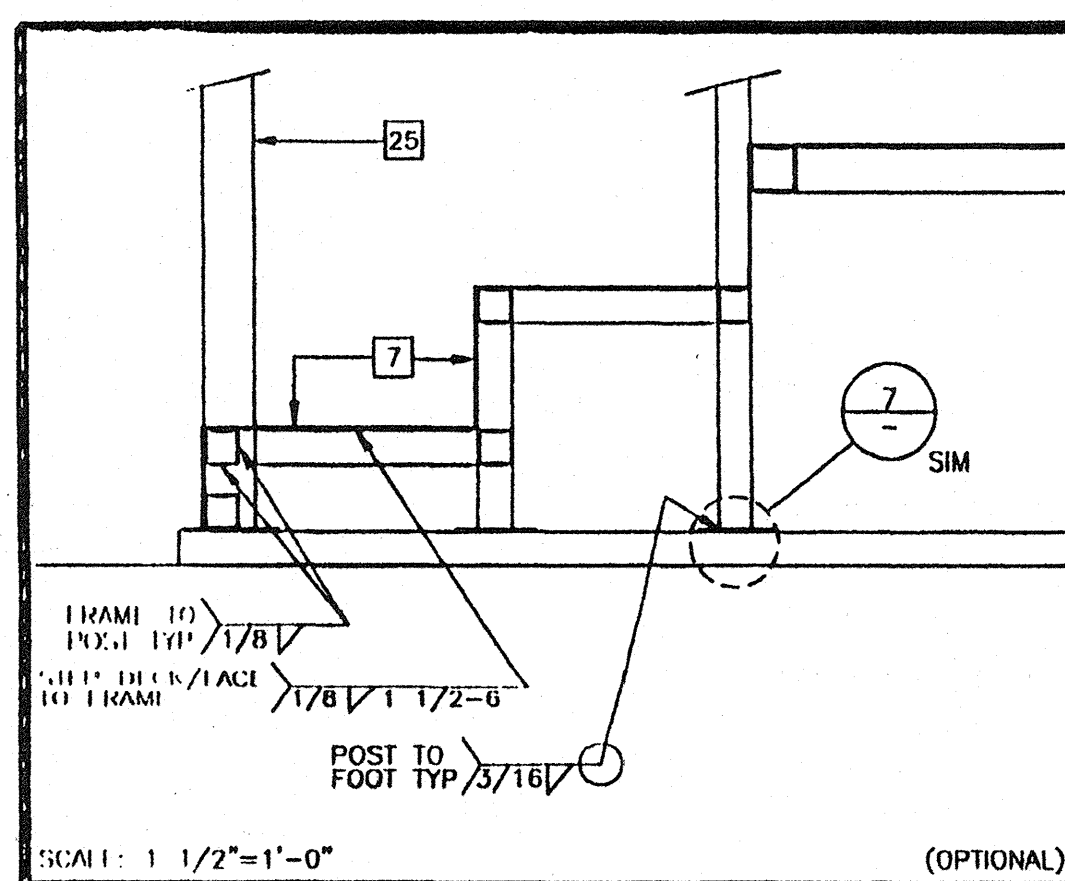

- ### KEY NOTES
- TS 2"x2"x14 GA
  - TS 1 1/2"x1 1/2"x14 GA (Fy = 39 KSI). ROUNDED OR RIVELED AT CORNERS.
  - TS 1"x1"x16 GA WHEELCHAIR GUIDE
  - 2"x6" PRESSURE TREATED SILL PLATE
  - 2"x4"x12 GA BASE PLATE WITH 2-1/4"x1" LAGS
  - SKIRTING: PLYWOOD TO MATCH BUILDING SIDING. BLOCK ALL EDGES. ATTACH WITH 8d AT 6" OC EDGES AND 12" OC FIELD. AT EDGE CONNECTION TO TS, USE #14x2" TLK SCREWS AT 6" OC
  - 12GA METAL DECK: NON-SLIP SURFACE. DESIGN COEFFICIENT OF FRICTION GREATER THAN 0.2. MAINTAINABLE FOR 1 YR. PROVIDE ROUNDED OR BEVELLED EDGES ON STAIR NOSING.
  - EXISTING BUILDING.
  - 6"x10"x12 GA BASE PLATE AT RAMP TOE.
  - LOWER LANDING BY DISTRICT
  - RAMP BY MODTECH
  - FLUSH TRANSITION
  - PAVE BY DISTRICT
  - 3"x1"x3"-0"x10 GA BENT PLATE
  - FASTEN POSTS WITH 3/8" DIA THRU BOLT, TYPICAL
  - RAMP LANDING, TYPICAL
  - 26 GA FLASHING
  - 3/8" DIAx2" LONG MB WITH NUT & WASHER
  - CAULKING
  - 6"x10GA CONTINUOUS PLATE WITH #14x2" TEK SCREWS AT 9" OC INTO WOOD OR FOUNDATION BLOCKS OR #14x2" TEK SCREWS INTO METAL AT 9" OC
  - PROVIDE DIVERSION FOR WATER FROM DOWNSHOUT FOR THIS CONDITION. BY DISTRICT
  - TS 1 1/4"x1 1/4"x14 GA (Fy = 39 KSI)
  - 4" MINIMUM BUILDING SEPARATION
  - 2" SLIP RESISTANT WARNING STRIPES MAX 1" FROM EVERY STAIR NOSING. USE CONTRASTING COLOR.
  - TS 2 1/2"x1 1/2"x8 GA ASTM A500 GRADE A
  - 2"x2" NAILER WITH 16d AT 12" OC

NO.	REVISIONS
1	
2	
3	
4	
5	
6	
7	
8	
9	
10	
11	
12	
13	
14	
15	
16	
17	
18	
19	

Electrical Engineer's Seal  
Mechanical Engineer's Seal  
Architect's Seal

IDENTIFICATION STAMP  
DIV. OF THE STATE ARCHITECT  
OFFICE OF REGULATION SERVICES  
PC-04  
101419  
AC: [Signature]  
DATE: OCT 25 1999

**MODTECH INC.**  
2830 BARRETT AVENUE  
PERRIS, CALIF. 92572  
PH (909) 943-4014  
FAX (909) 940-0427

PROJECT NUMBER: [Blank]  
© MODTECH, INC. 1999

IDENTIFICATION STAMP  
DIV. OF THE STATE ARCHITECT  
OFFICE OF REGULATION SERVICES  
APPROVED: [Signature]  
DATE: 7/24/14  
IDENTIFICATION STAMP  
DIV. OF THE STATE ARCHITECT  
OFFICE OF REGULATION SERVICES  
04:01984  
AC: [Signature]  
DATE: MAR 09 2000

DRAWN BY: [Blank]  
DATE: [Blank]  
CHECKED BY: SS  
DATE: 10/22/99  
MODTECH Index No. [Blank]

# R1.02

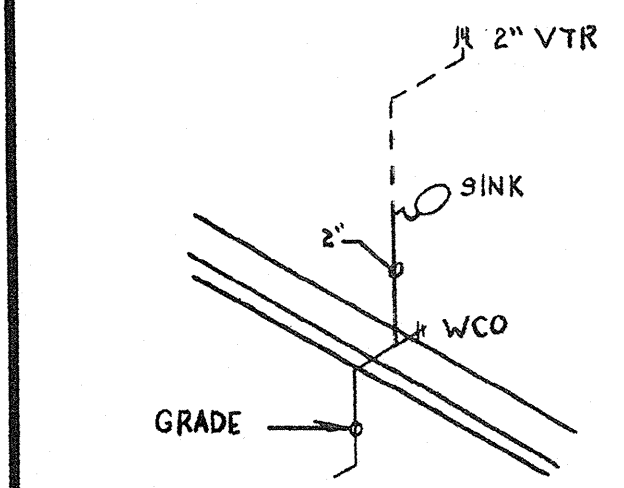
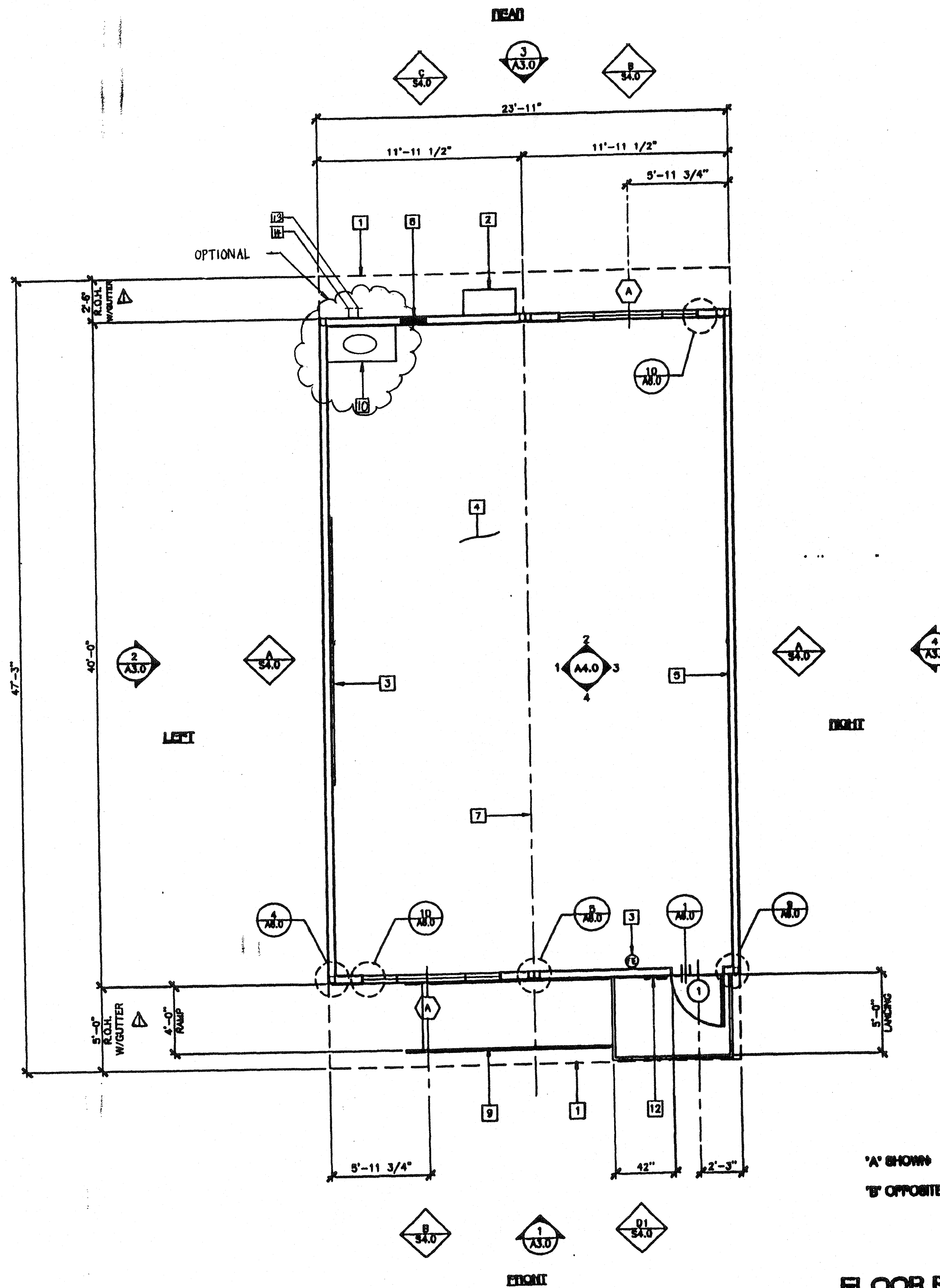

SCALE: NTS  
PIPE SHALL BE TYPE 'L' COPPER  
SINK CABINET WASTE 1

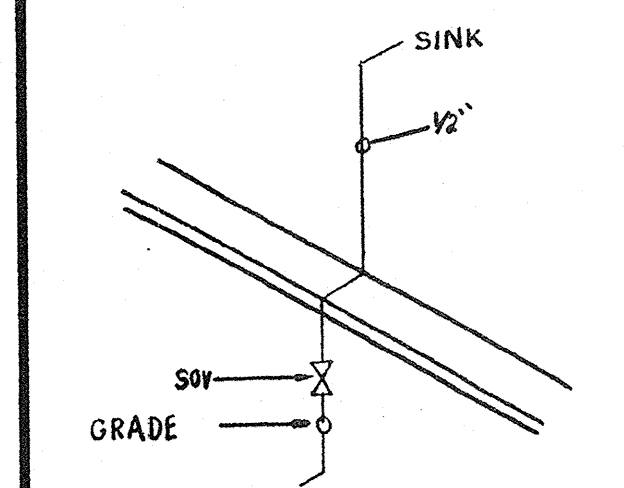

SCALE: NTS  
PIPE SHALL BE TYPE 'L' COPPER  
SINK CABINET COLD WATER SUPPLY 2

**KEY NOTES**

- 1 ROOF OVERHANG
- 2 HVAC UNIT (HV)
- 3 2 - 8'x4' MARKER BOARDS (SEE SPEC'S FOR TYPE)
- 4 FINISH FLOORING (FIN)
- 5 INTERIOR FINISH (FIN)
- 6 FIRE EXTINGUISHER - 5 LBS DRY CHEMICAL WITH 2A-10BC UL RATING WALL MOUNTED BRACKET, HANDLE AT 48" AFF
- 7 MODLINE (M)
- 8 ELECTRICAL PANEL
- 9 RAMP/LANDING (RMP)
- 10 SINK CABINET OPTIONAL LAV: KOHLER # K-2867 FAUCET CHICAGO 833-669
- 11 NOT USED
- 12 SIGNAGE PROVIDED AND INSTALLED BY DISTRICT PRIOR TO OCCUPANCY, SEE A.S.O.
- 13 COLD WATER SUPPLY
- 14 WASTE AND VENT P.O.C.

**NOTES**

- 1. METAL TAG ON ALL MODULES, MECHANICALLY ATTACHED TO REAR EXTERIOR OF BUILDING SHOW D.S.A. APPLICATION NUMBER, MANUFACTURER'S NAME AND SERIAL NUMBER.
- 2. METAL TAG MIN. 3 1/2"X1 1/2" METAL I.D. W/  
1. DESIGN WIND LOAD  
2. DESIGN ROOF LOAD
- 3. PROVIDE MIN. 3 1/2"X1 1/2" METAL TAG INSTALLED INSIDE THE ELECTRICAL PANEL SHOWING OPSC NUMBER AND DSA NUMBER.

IDENTIFICATION STAMP  
DIV. OF THE STATE ARCHITECT  
OFFICE OF REGULATION SERVICES  
04 01984  
AC 6 FLS SS TB  
DATE MAR 08 2000

IDENTIFICATION STAMP  
DIV. OF THE STATE ARCHITECT  
APPROX 115000  
AC 11 FLS SS TB  
DATE 1/22/14

**FLOOR PLAN** 24x40  
SCALE: 1/4" = 1'-0"

PC  
CBC 1998

**REVISIONS**

1	CLARIFY OVERHANGS	SS
2		
3		
4		

Electrical Engineer's Seal  
Mechanical Engineer's Seal  
Architect's Seal

SEVERN COUNTY DEPT. OF THE STATE ARCHITECT OFFICE OF REGULATION SERVICES  
PC-04  
10149  
DATE 06/23/99

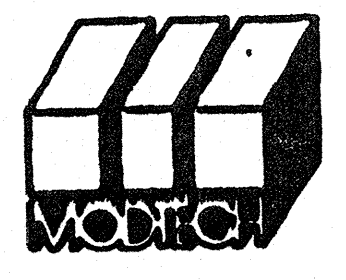

**MODTECH INC.**  
2830 BARRETT AVENUE  
PERRIS, CALIF. 92572  
PH (909) 943-4014  
FAX (909) 940-0427

PROJECT NUMBER:

© MODTECH, INC. 1999

DRAWN BY:  
DATE:  
CHECKED BY: SS  
DATE: 10/22/99

**FLOOR PLAN**

**A1.0**

FILE PATH: 2440-0-A1-01.DWG PROJECT NO. 3405



### ELECTRICAL PANEL SCHEDULE

MAIN: 100 AMP 12 POLE	PANEL A				FEED: REAR			
	LOCATION: REAR/INTERIOR				MOUNTING: FLUSH			
LOAD	WATTS		BREAKER		WATTS		LOAD	
	AP	BP	Amps	P	AP	BP	Watts	
RECEPTACLE (4)	720		20	1	2	2	3360	HVAC (3 1/2T)
RECEPTACLE/CLOCK (5)		720	20	1	3	4	3360	HVAC (3 1/2T)
				5	6	2	2500	HEAT STRIPS (DKW)
				7	8	-	2500	HEAT STRIPS (DKW)
INT/EXT LIGHTS (11)	760		20	1	9	10		
INT. LIGHTS (10)		700	20	1	11	12		
WATTS/PHASE	A = 7340 1480 1420				B = 7320		WATTS/PHASE	
TOTAL	14810	WATTS	62	AMPS	120/240	VOLTS	SINGLE #	THREE WIRE
NCL =	13080	WATTS						

### GENERAL GROUNDING NOTES

- EACH BUILDING SHALL BE SEPARATELY GROUNDING WITH A 3/4" RD. X 8' COPPERCLAD STEEL GROUND ROD, WHERE ROCK BOTTOM IS ENCOUNTERED, ROD SHALL BE DRIVEN AT AN ANGLE NOT TO EXCEED 45 DEGREE'S FROM THE VERTICAL OR SHALL BE BURIED IN A TRENCH THAT IS AT LEAST 30" DEEP (BY SITE ELECTRICAL)
- TESTING: TEST FOR RESISTANCE TO GROUND, IF RESISTANCE EXCEEDS 25 OHMS, INSTALL ADDITIONAL GROUND RODS SEPARATED AT LEAST 6'-0" UNTIL RESISTANCE IS REDUCED TO 25 OHMS OR LESS. (BY SITE ELECTRICAL)
- APPROVAL OF THIS PLAN DOES NOT CONSTITUTE APPROVAL OF THIS FIRE ALARM FOR ALL SITES, THE FIRE ALARM SYSTEM AND/OR COMPONENTS MAYBE REQUIRED TO BE CHANGED DUE TO SITE LOCATION, EXISTING CONDITIONS OR INCOMPATIBLE COMPONENTS.
- GROUNDING TEST SHALL BE DONE IN THE PRESENCE OF THE PROJECT INSPECTOR, ALL GROUNDING SHALL BE IN ACCORDANCE WITH CEC ARTICLE 250.

### ELECTRICAL LEGEND

- 2'x4' 4 TUBE FLUORESCENT LIGHT FIXTURE
- EXTERIOR LIGHT FIXTURE AT +93" AFF
- SWITCH AT +48" AFF
- DUPLEX WALL RECEPTACLE 15A 125V 3 WIRE AT +18" AFF UNW
- HVAC UNIT (HV)
- 4SD J-BOX FOR FIRE ALARM PULL STATION AT +48" AFF, 3/4" CO TO PULLSTRING
- 4SD J-BOX FOR FIRE ALARM STROBE AT +80" AFF, 3/4" CO TO PULLSTRING
- 4SD J-BOX FOR FIRE ALARM HORN AT +18" AFF, 3/4" CO TO PULLSTRING
- WEATHER PROOF GUTTER BOX (6"x6"x4") AT +18" AFF RECEIVE 3/4" CO FROM FA DEVICE, PULLSTRING
- ELECTRICAL PANEL AT +80" AFF TO CENTERLINE 1 1/4" POWER NIPPLE POC, GND JUMPER BY SITE ELECT
- CLOCK AT +90" AFF
- DATA LINE
- 4SD J-BOX FOR OPTIONAL SMOKE DETECTOR (CFL)
- 4SD J-BOX FOR OPTIONAL FIRE ALARM (CFL)

\* SMOKE & HEAT DETECTORS SHOWN ARE FOR OPTION AUTOMATIC DETECTION. OF ELECTED AS AN OPTION THEY MUST BE PROVIDED BY DISTRICT. NO PROVISIONS WILL BE MADE UNDER THIS CONTRACT.

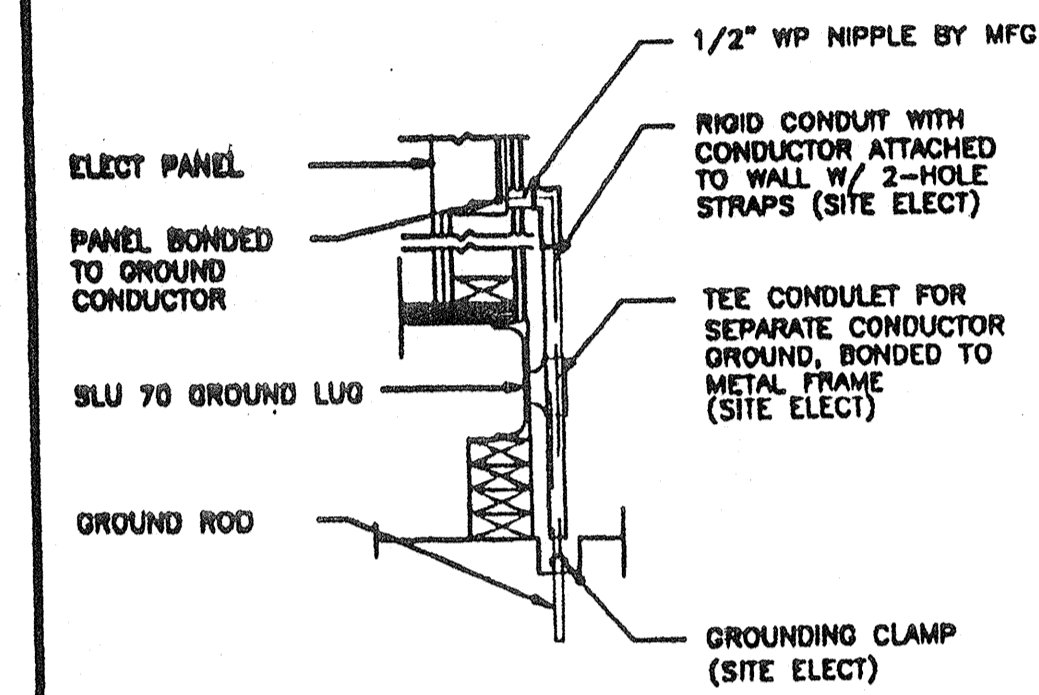
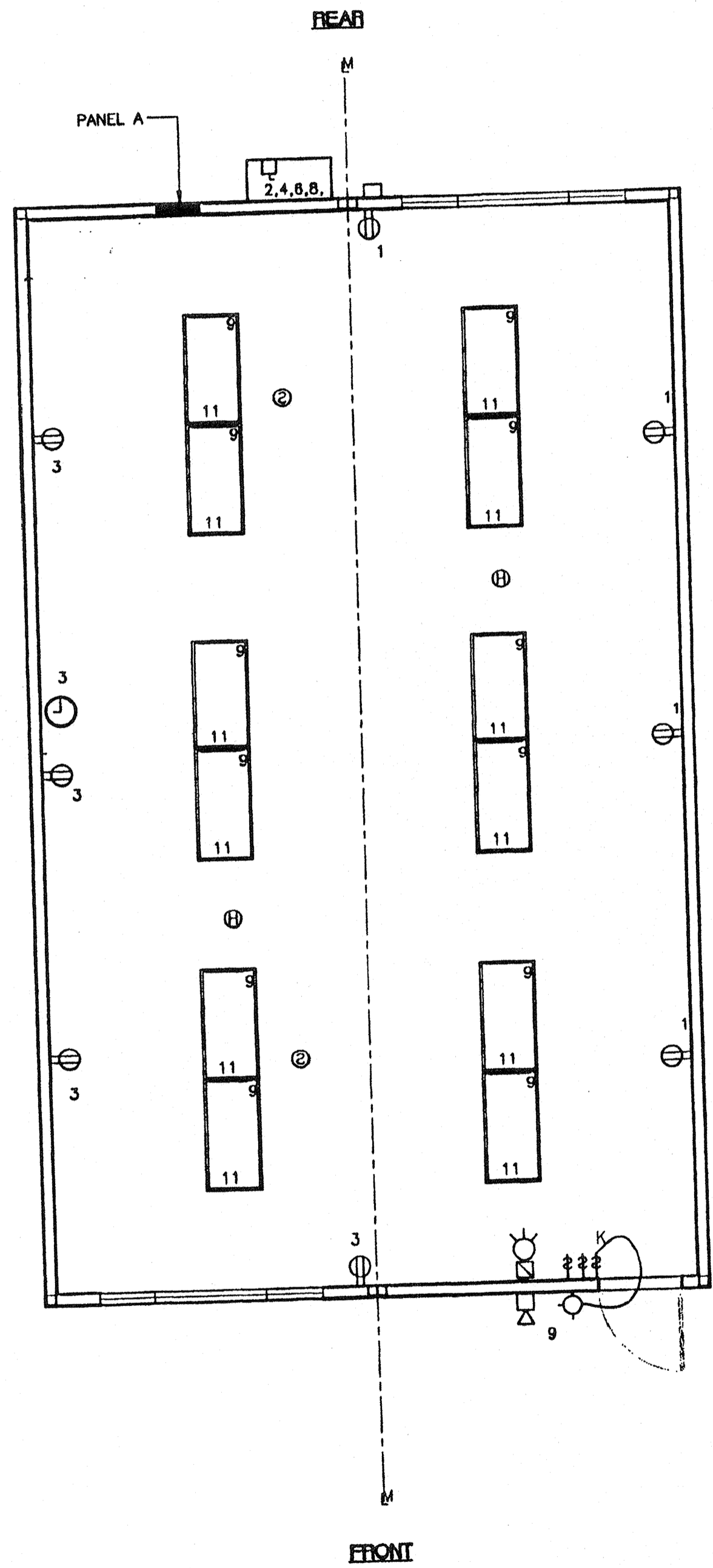

TYP GROUNDING DETAIL 1

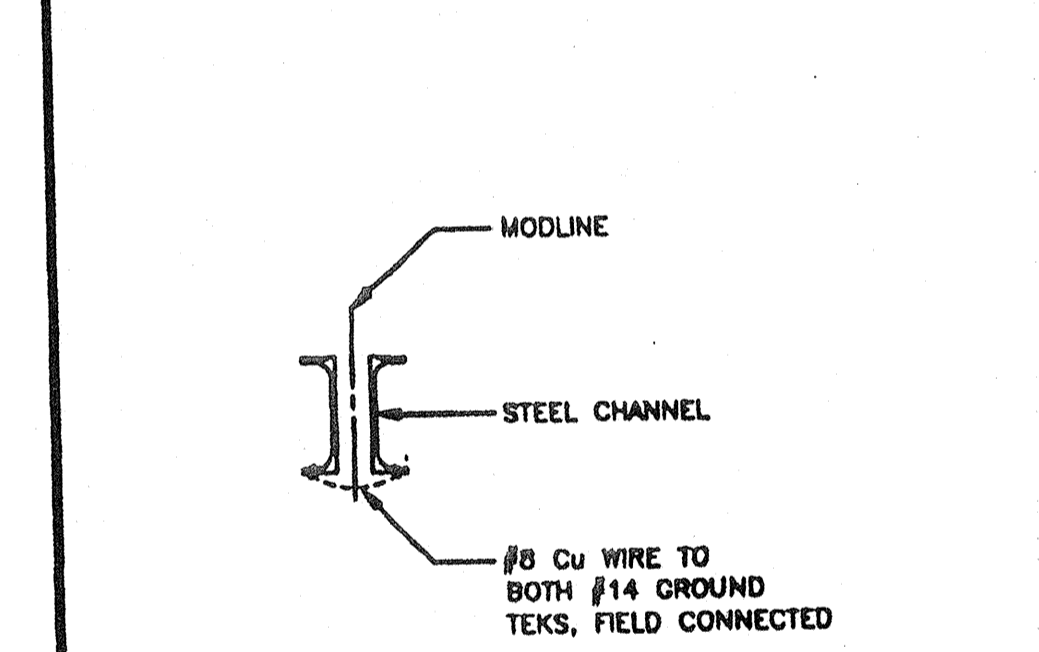

GROUND JUMPER • MOD LINE 2

### NOTES

- SCHOOL EQUIPMENT ANCHORAGE  
THE FOLLOWING IS FOR THE ARCHITECTS INFORMATION ONLY:  
THE SEISMIC ANCHORAGE OF ELECTRICAL EQUIPMENT SHALL CONFORM TO COR TITLE 24, SECTION 1632A AND TABLE 16A-0. ANCHORAGE DETAILS FOR ROOF/FLOOR MOUNTED EQUIPMENT WEIGHING LESS THAN 400 LBS & HUNG EQUIPMENT WEIGHING LESS THAN 20 LBS MAY BE OMITTED FROM THE PLANS.  
FOR ELECTRICAL DRAWINGS:  
ALL ELECTRICAL EQUIPMENT SHALL BE BRACED OR ANCHORED TO RESIST A HORIZONTAL FORCE ACTING IN ANY DIRECTION USING THE FOLLOWING CRITERIA:  
EQUIPMENT ON GRADE 20% OF OPERATING WEIGHT  
EQUIPMENT ON STRUCTURE 30% OF OPERATING WEIGHT  
FOR FLEXIBLY MOUNTED EQUIPMENT USE 4 TIMES THE ABOVE VALUES, AND FOR SIMULTANEOUS VERTICAL FORCE USE 1/3 TIMES THE HORIZONTAL FORCE!  
THE ABOVE VALUES ARE FOR AN IMPORTANCE FACTOR, I = 1.0 AND SEISMIC ZONE, Z = 4  
WHERE ANCHORAGE DETAILS ARE NOT SHOWN ON THE DRAWINGS THE FIELD INSTALLATION SHALL BE SUBJECT TO THE APPROVAL OF THE ARCHITECT AND THE FIELD ENGINEER OF THE OFFICE OF THE STATE ARCHITECT.

ELECTRICAL PLAN (24'x40') SCALE: 1/4" = 1'-0"

CBC 1999

IDENTIFICATION STAMP  
DIV. OF THE STATE ARCHITECT  
OFFICE OF REGULATION SERVICES  
04 101984  
AC JWS  
DATE MAR 18 2014

IDENTIFICATION STAMP  
DIV. OF THE STATE ARCHITECT  
APPROX 110000  
AC JWS  
DATE 7/24/2014

REVISIONS	DESCRIPTION	DATE

Professional Engineer's Seal: Electrical Engineer's Seal, Mechanical Engineer's Seal, Architect's Seal

PC-04 10419  
DATE 10/21/1999

**MODTECH INC.**  
2830 BARRETT AVENUE  
PERRIS, CALIF. 92572  
PH (909) 943-4014  
FAX (909) 940-0427

PROJECT NUMBER: © MODTECH, INC. 1999  
DRAWN BY: DATE: 10/22/99  
CHECKED BY: DATE: 10/22/99  
MODTECH Index No. **E1.0**  
ELECTRICAL PLAN w/o DATA 24'x40'

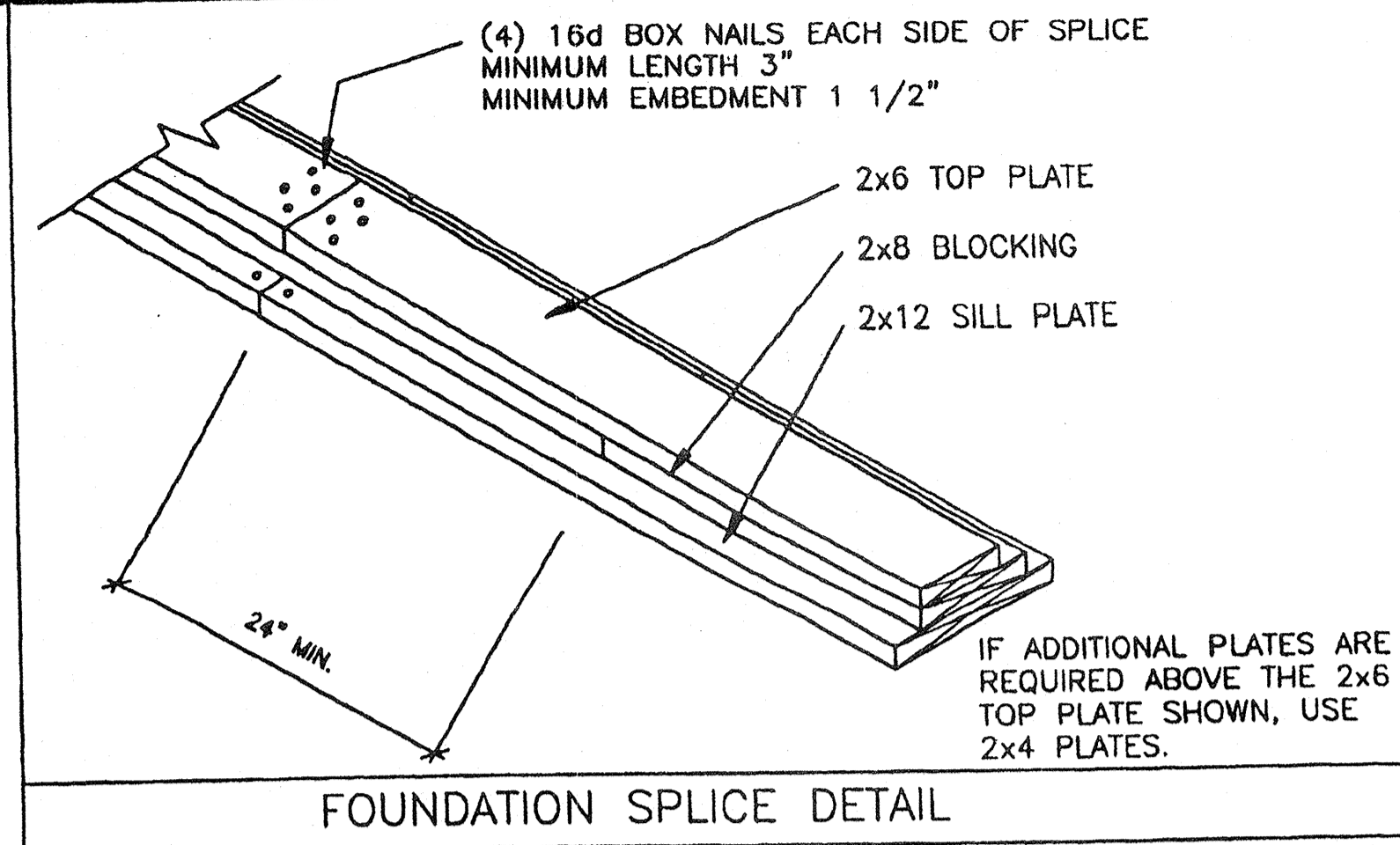
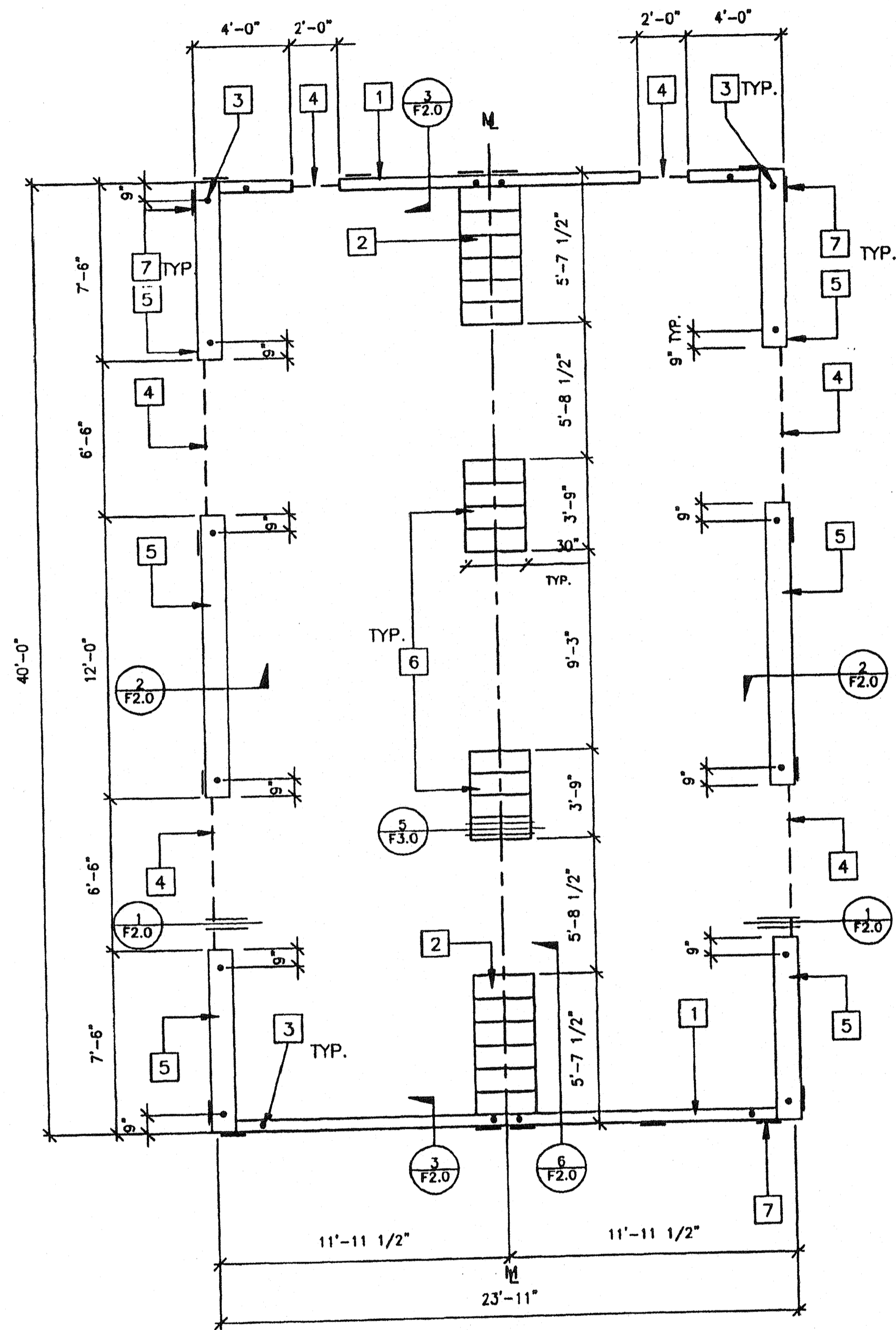

**KEY NOTES**

- 1 2"x6" SILL PLATE (END WALL)
- 2 6- 2X12X30" LONG SILL PADS
- 3 PIPE TO GRADE (TYP.)
- 4 3" HIGH BY 6'-6" LONG VENT @ SIDEWALLS  
3" HIGH BY 2'-0" LONG VENT @ ENDWALLS
- 5 2X12 SILL PLATE (SIDE WALL)
- 6 4-2X12X30" LONG SILL PADS
- 7 6"x12"x10 GA. PLATES  
5 @ ENDWALL, 4 @ SIDEWALL
- 8 NOT USED
- 9 NOT USED

**NOTES**

1. SILL RESTRAINT: ON A.C. PAVING AND ON SOIL 1" O.D. GALVANIZED PIPE AT 10'-0" 12" PENETRATION BELOW SURFACE VERTICALLY. DRILL SILL 1-1/4" MAX. PIPE MAY BE DRIVEN MAX. OF 45° ANGLE TO VERTICAL. (18-1/2" LONG PIPE REQUIRED FOR PENETRATION AT 45° ANGLE.)
  2. ON CONCRETE PAVING HILTI DS 82-P10 THRU SILL PLATE:  
END WALLS: 8" O.C.  
SIDE WALLS: 22" O.C.
  3. WHERE SHIM STOCK IS REQUIRED FOR LEVELING USE 1/4", 1/2", OR 3/4" THICK PLYWOOD SAME WIDTH AS BLOCK. P.T.
  4. VERIFY DRAINAGE TO PREVENT WATER FROM PONDING BENEATH THE STRUCTURE. WITH DISTRICT ARCHITECT SITE PLANS
  5. ALL FOUNDATION MATERIAL SHALL BE DOUGLAS FIR  
GROUND CONTACT: LP-22 (CCA .40)  
ABOVE GROUND: LP-2 (CCA .25)
  6. ALLOWABLE SOIL BEARING: 1000 P/SF
  7. "MACHINE APPLIED 16d FASTENERS SHALL HAVE AN EMBEDMENT OF NOT LESS THAN 1 1/2" INTO SECOND MEMBER, AND SHALL BE NOT LESS THAN 3" IN OVERALL LENGTH"
- THE ABOVE NAILS SHALL ALSO BE ACCEPTABLE FOR HAND NAILING, PROVIDED THE REQUIRED EMBEDMENT IS MAINTAINED.

**VENT CALCS.**

BLD'G SIZE 24' X 40' = 960  
 VENTILATION REQ'D 960 + 150 = 6.4SF  
 3"x6'-6" VENT=1.625SF X 4 = 6.5SF  
 3"x2'-0" = 0.5 SF X 2 = 1.0 SF  
 TOTAL VENTING PROVIDED = 7.5 SF

**FOUNDATION - WOOD SILL** 24' X 40' 50 PSF LL  
 SCALE 1/4" = 1'

CBC 1999

PC

IDENTIFICATION STAMP  
 DIV. OF THE STATE ARCHITECT  
 OFFICE OF REGULATION SERVICES  
 04 101984  
 AC DATE 04/03/2000

IDENTIFICATION STAMP  
 DIV. OF THE STATE ARCHITECT  
 OFFICE OF REGULATION SERVICES  
 APPROV 115000  
 AC DATE 10/22/99

REVISIONS	Electrical Engineer's Seal	Mechanical Engineer's Seal	Architect's Seal

Electrical Engineer's Seal

Mechanical Engineer's Seal

Architect's Seal

Architect's Seal

IDENTIFICATION STAMP  
 DIV. OF THE STATE ARCHITECT  
 OFFICE OF REGULATION SERVICES  
 PC-04  
 101419  
 AC DATE 01/23/99

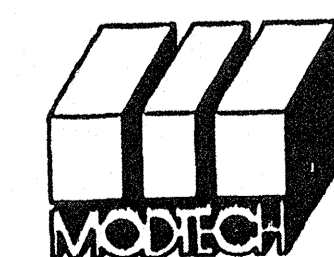

**MODTECH INC.**  
 2830 BARRETT AVENUE  
 PERRIS, CALIF. 92572  
 PH (909) 943-4014  
 FAX (909) 940-0427

PROJECT NUMBER: © MODTECH, INC. 1999

DRAWN BY:  
 DATE:  
 CHECKED BY: SS  
 DATE: 10/22/99

**FOUNDATION PLAN**

MODTECH Index No.  
**F1.0**

FILE PATH: 2440-0-F1-00.rvt

PROJECT NO. PC-04-101419

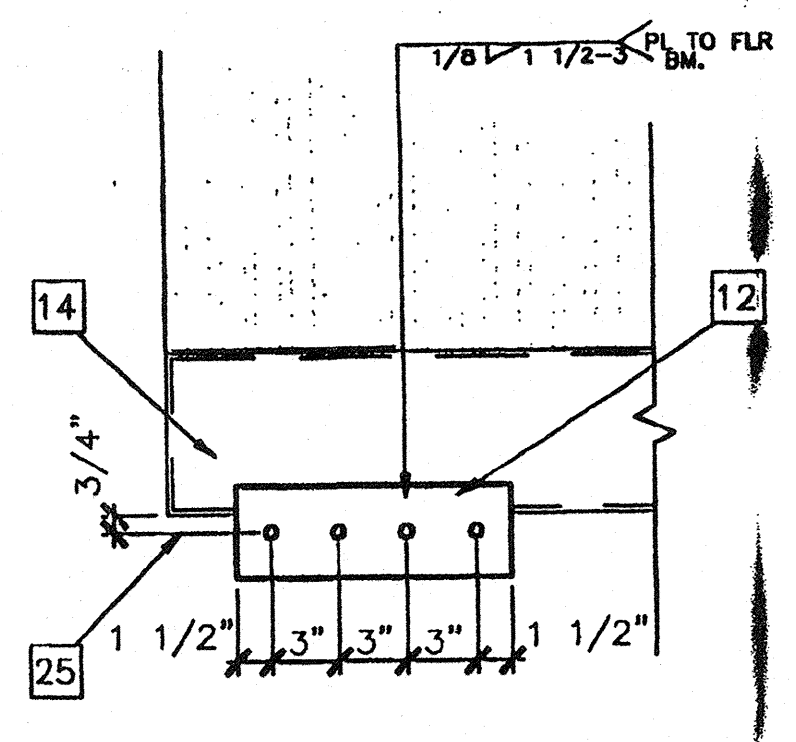

9 SCALE: 1 1/2"=1'-0"  
ALTERNATE TIE PLATE

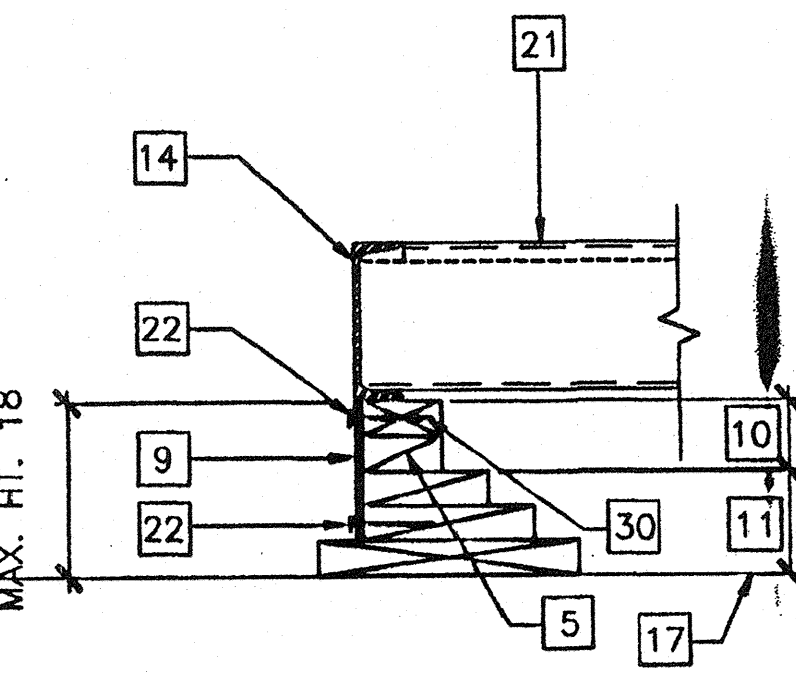

10 SCALE: 1 1/2"=1'-0"  
ADD BLK'S/SHIMS TO LEVEL FOUND.

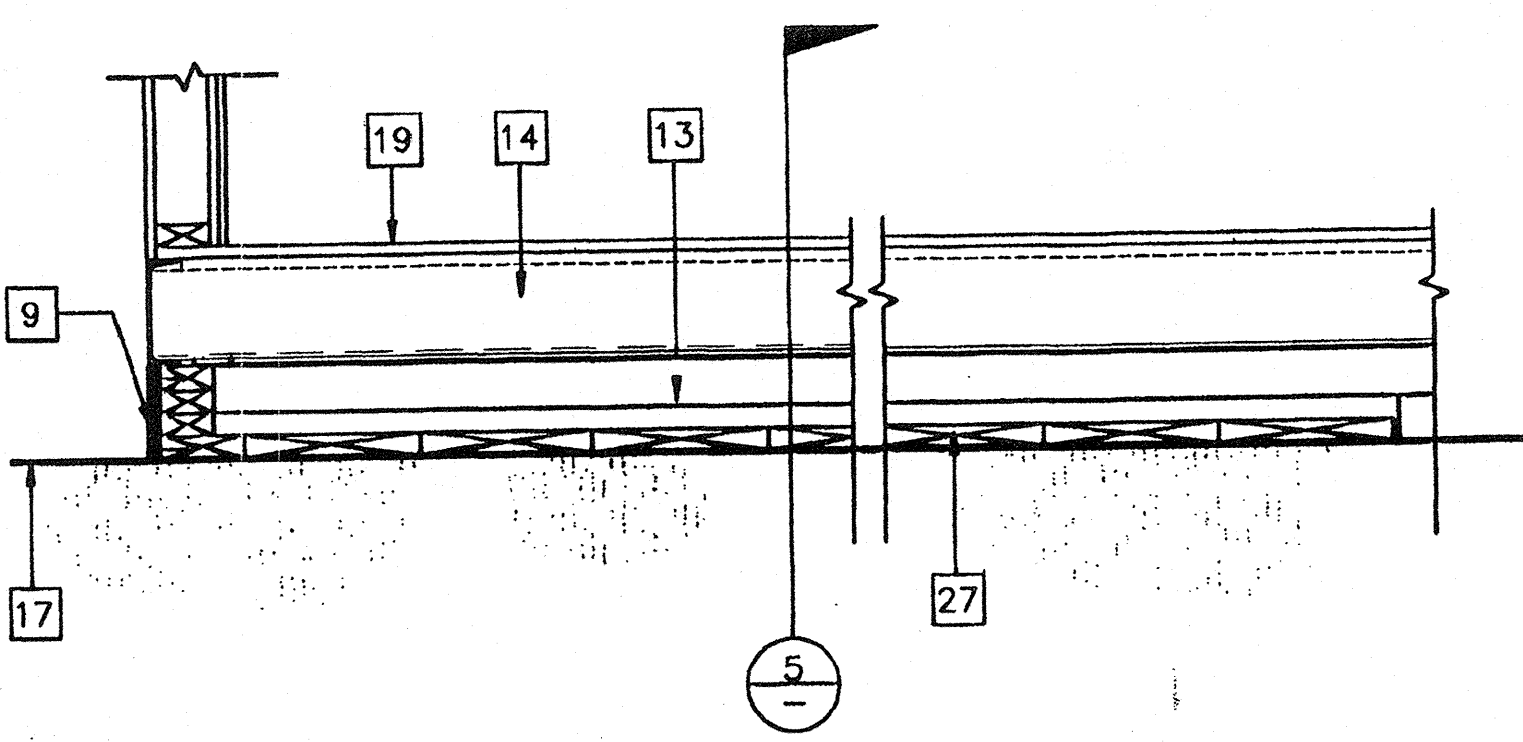

6 SCALE: 1 1/2"=1'-0"  
MODLINE PAD @ END WALL

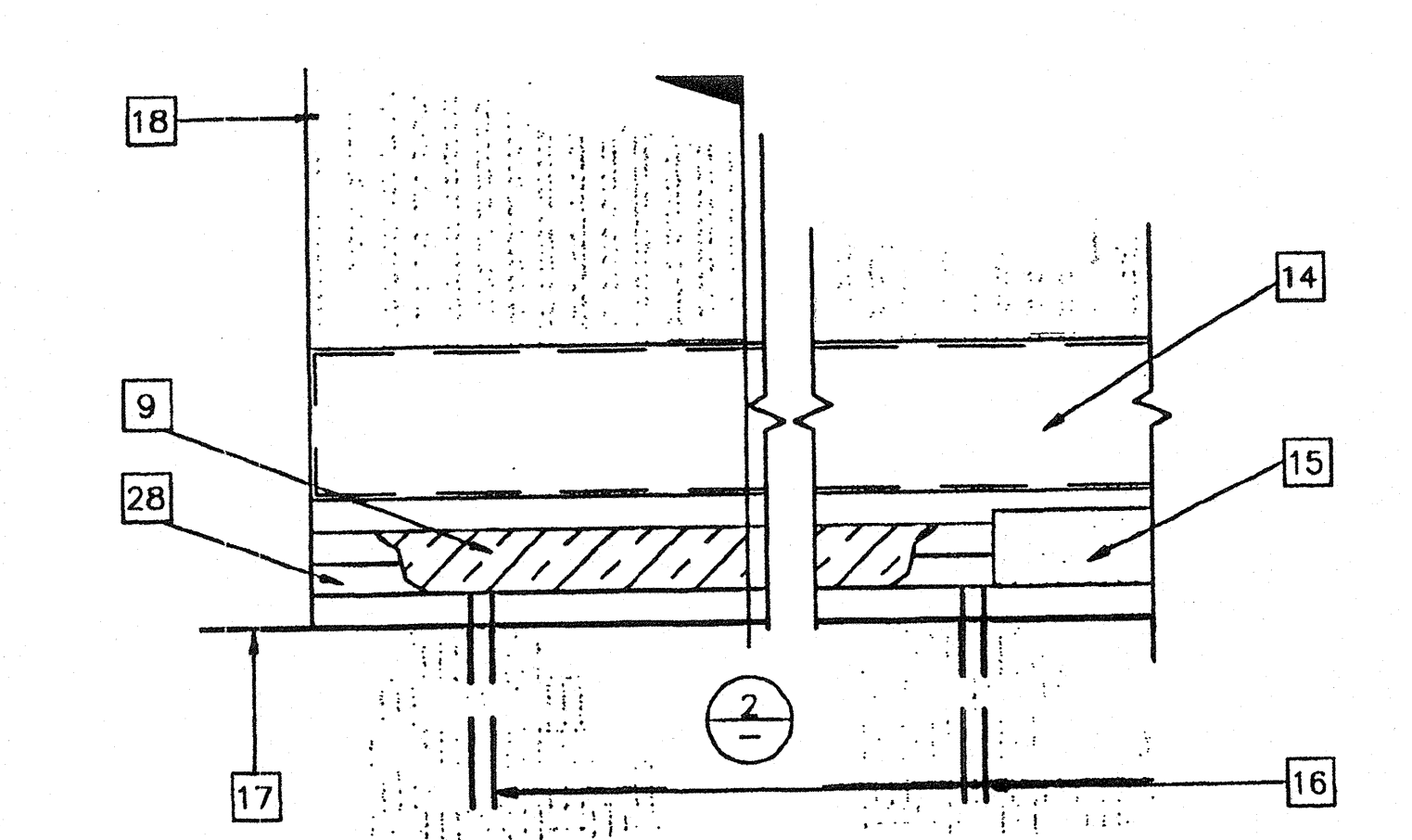

7 SCALE: 1 1/2"=1'-0"  
FOUNDATION ELEVATION @ SIDE WALL

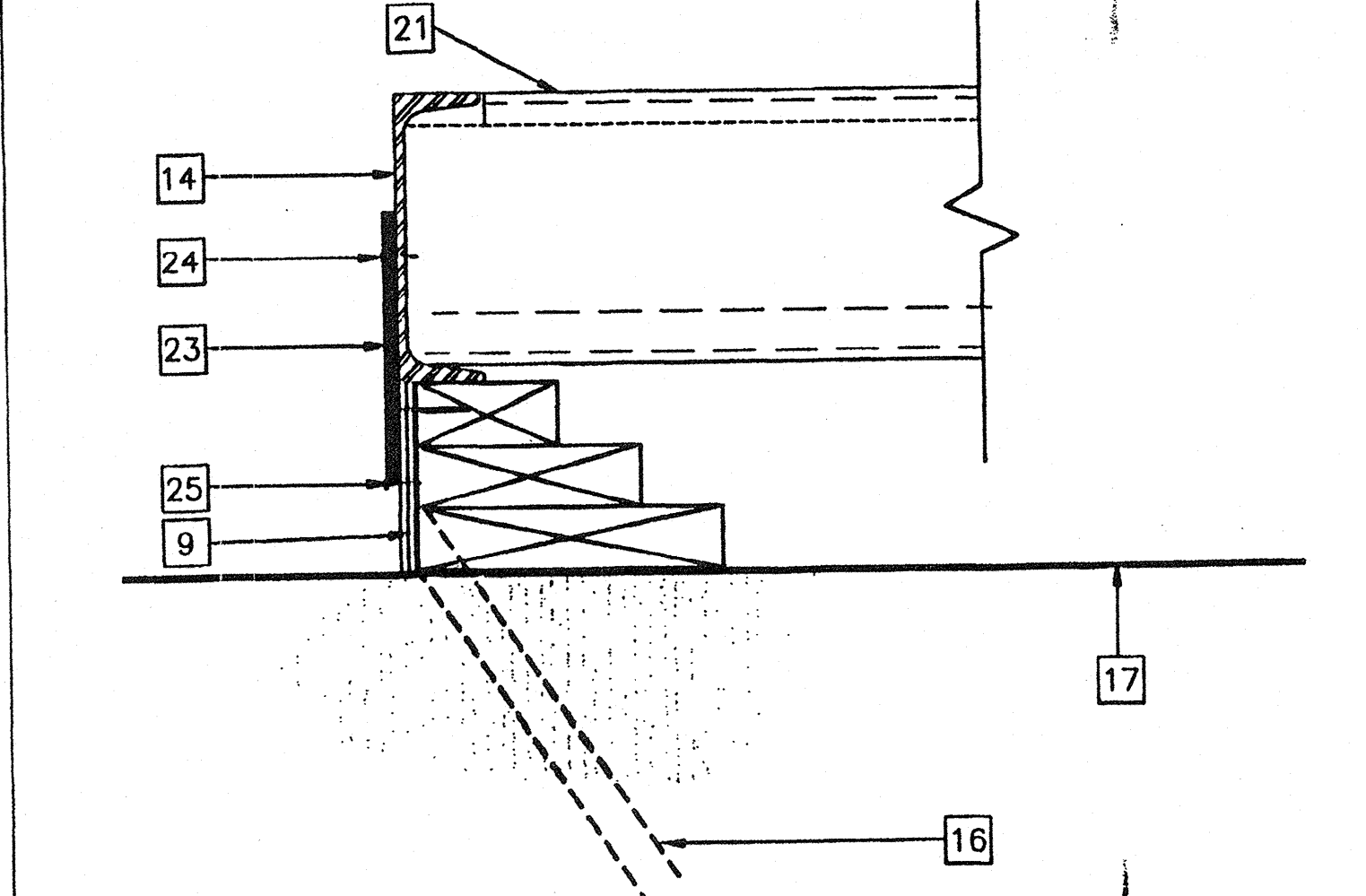

8 SCALE: 3"=1'-0"  
TYPICAL TIE PLATE

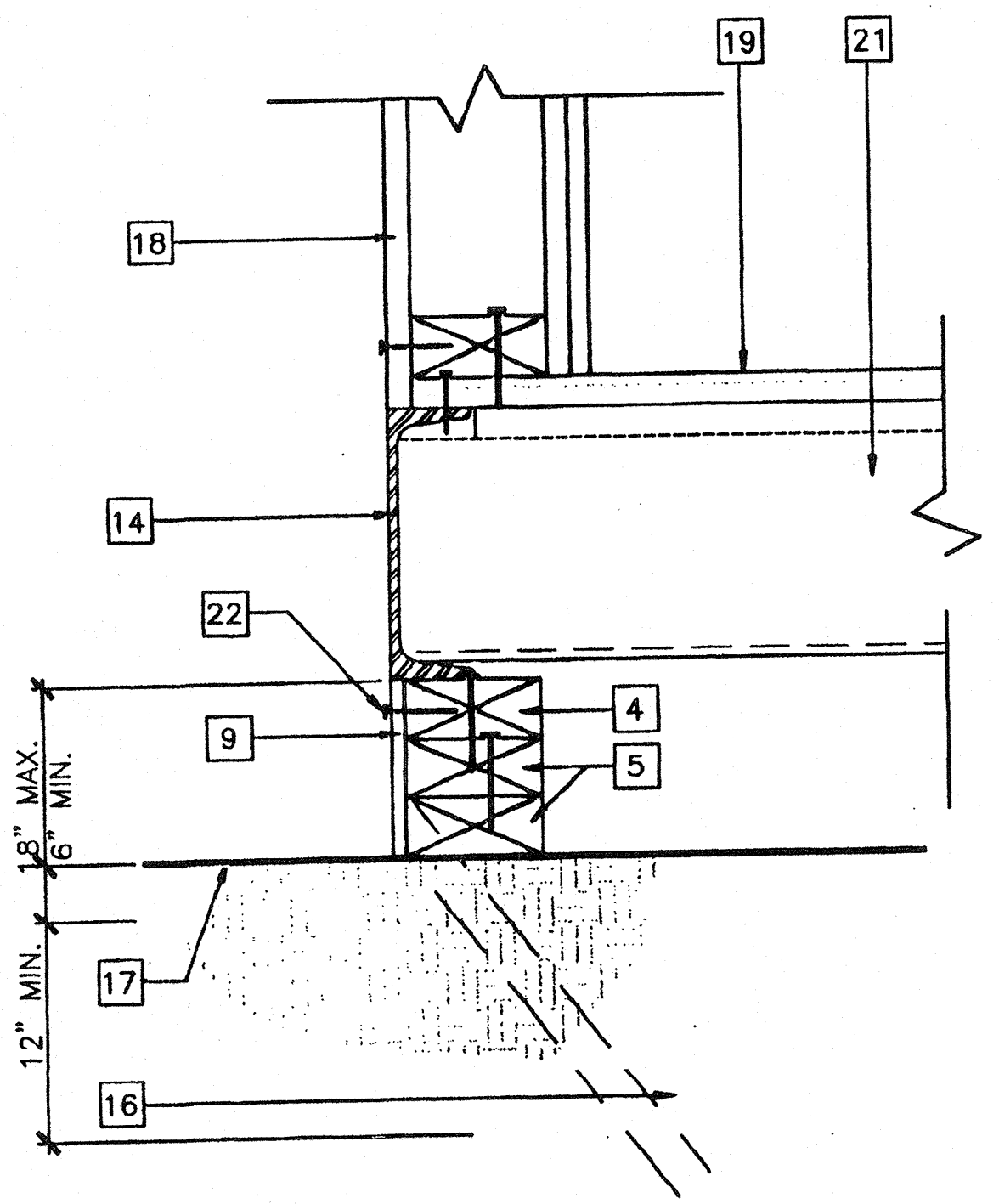

3 SCALE: 3"=1'-0"  
FOUNDATION @ END WALL

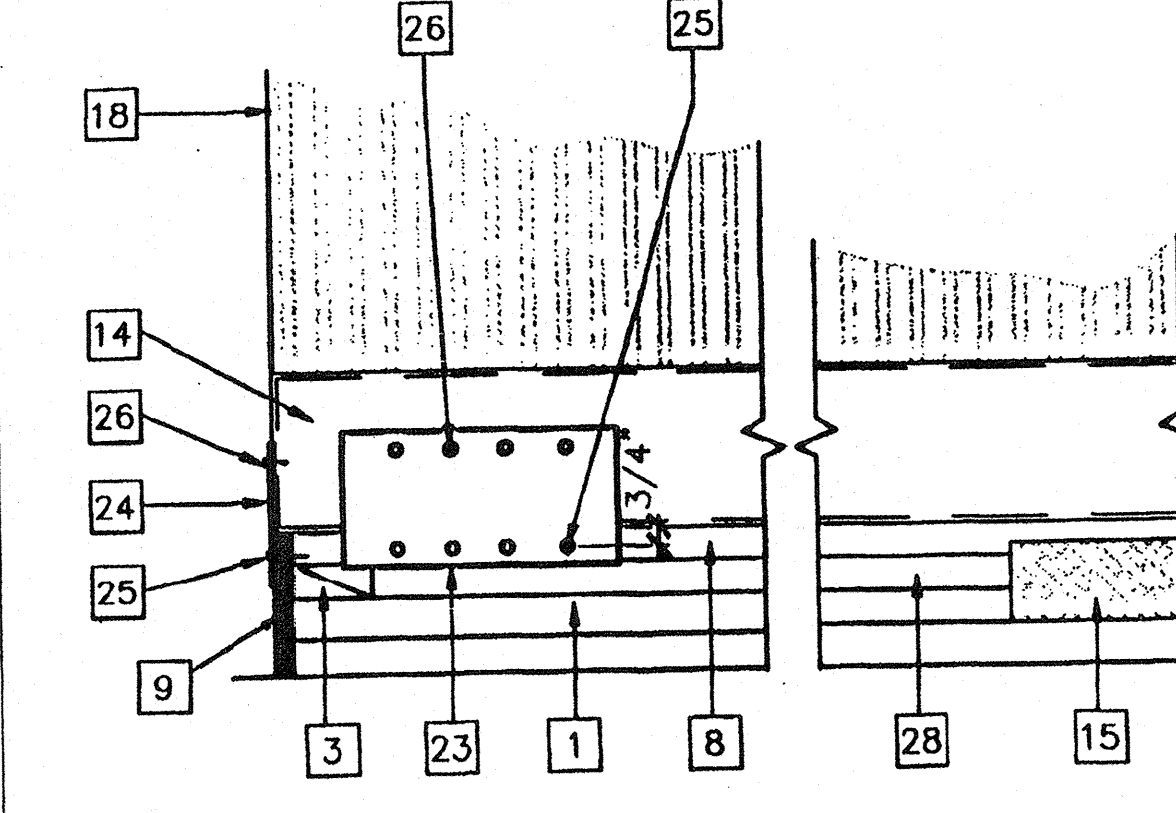

4 SCALE: 1 1/2"=1'-0"  
DETAIL @ FOUNDATION CORNER

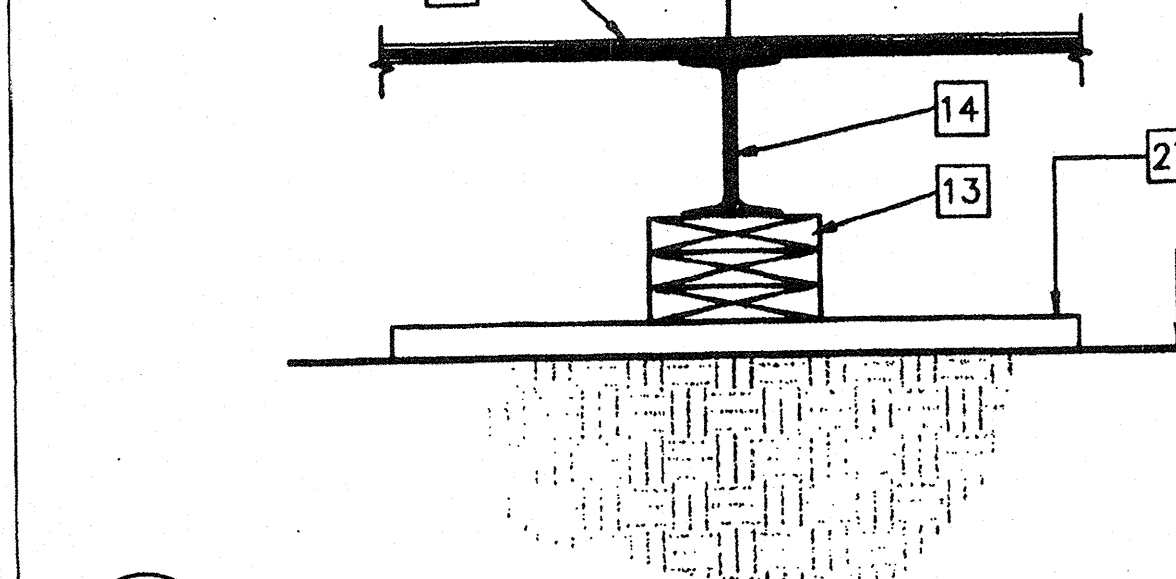

5 SCALE: 1 1/2"=1'-0"  
FOUNDATION PAD @ MODLINE

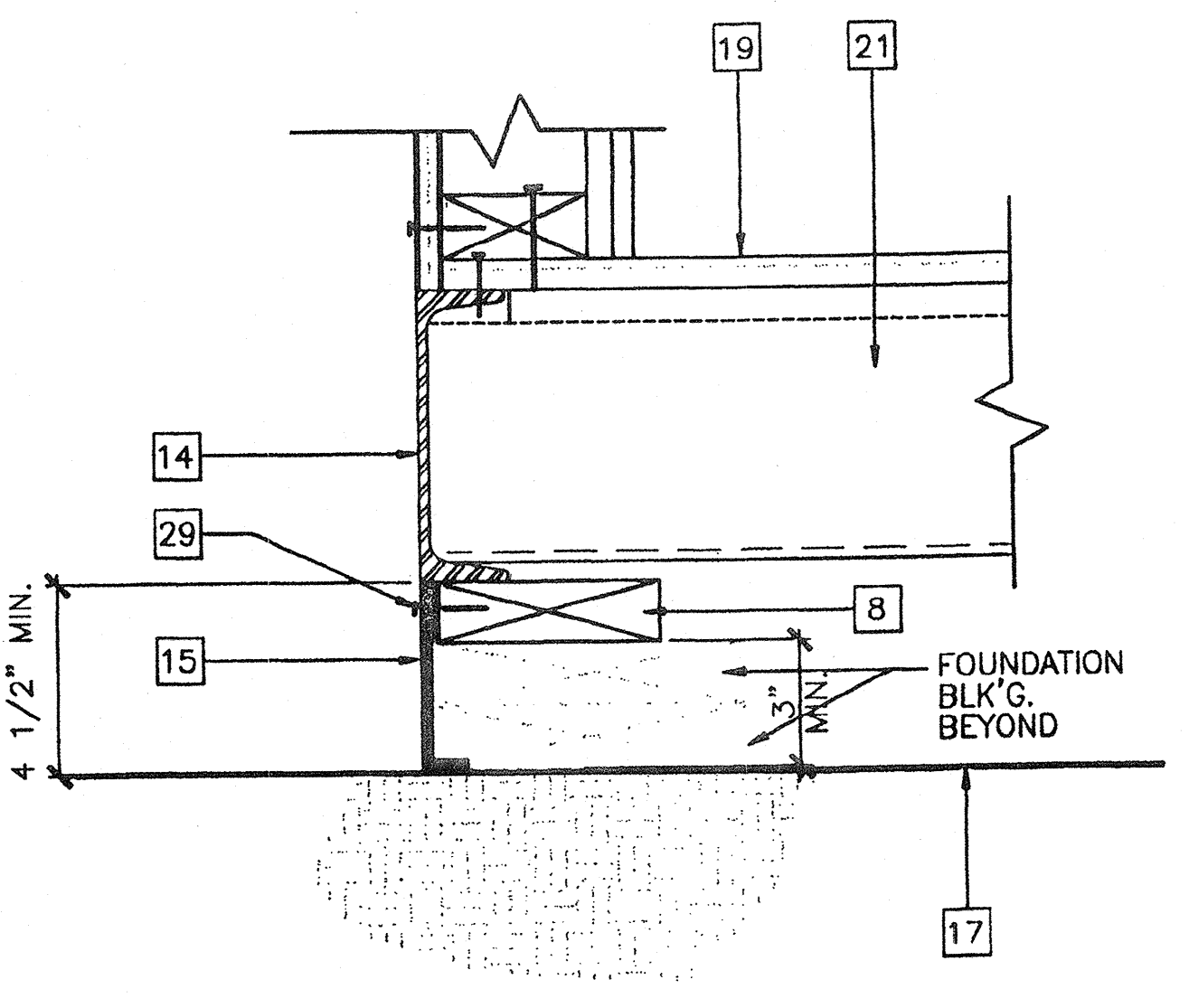

1 SCALE: 3"=1'-0"  
FOUNDATION VENT

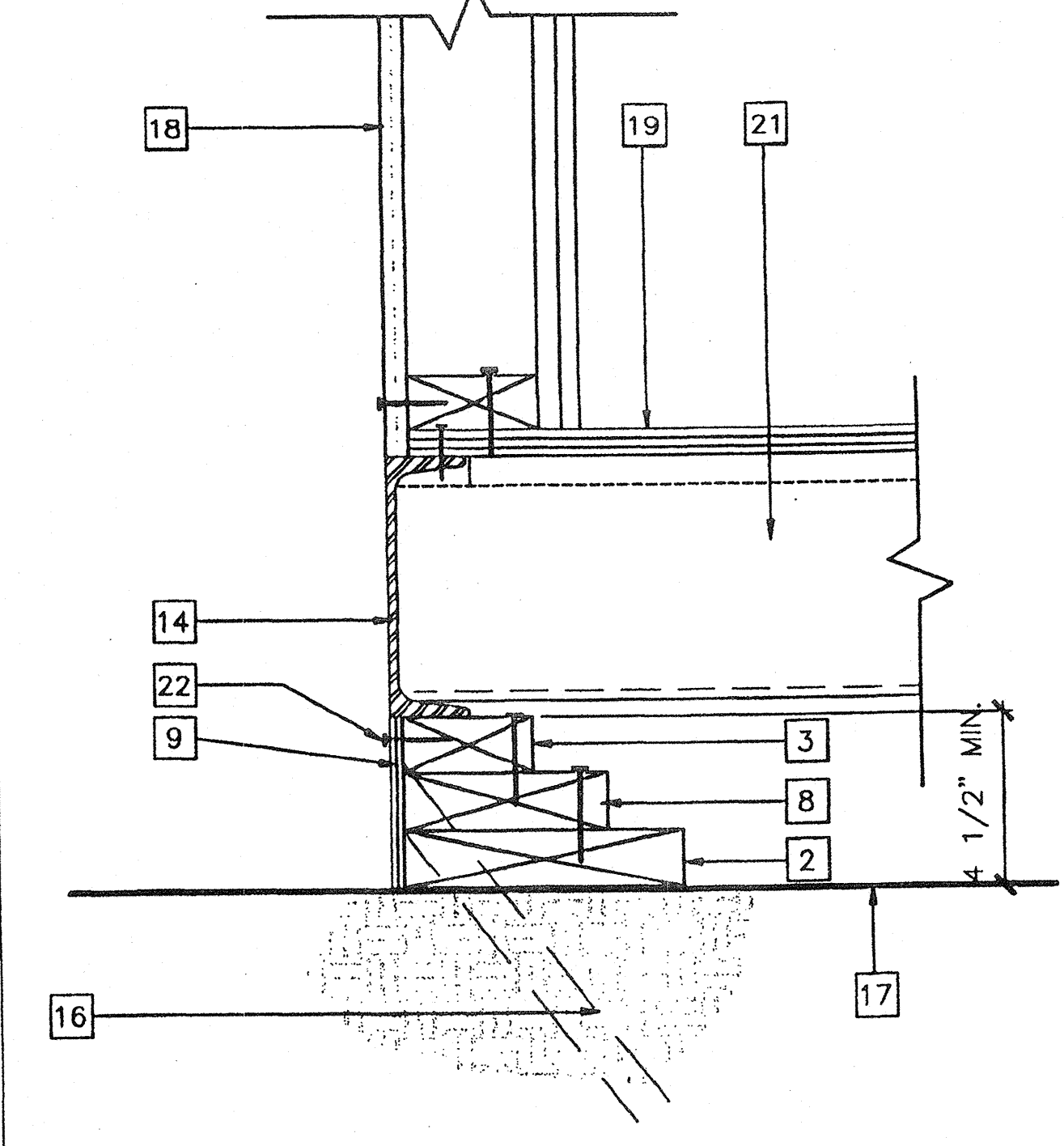

2 SCALE: 3"=1'-0"  
FOUNDATION @ SIDE WALL

- KEY NOTES**
- 1 2X12 SILL PLATE SEE FOUND. PLAN FOR LENGTH
  - 2 2X8 TOP PLATE W/16d AT MAX. 5" O.C. TO SILL PLATE
  - 3 2X4 CONT. TOP PLATE W/16d AT MAX. 12" O.C.
  - 4 2X4 TOP PLATE CONT. W/16d AT MAX. 12" O.C.
  - 5 2X4 BLOCKING W/16d MAX. 12" O.C. TO SILL PLATE
  - 6 NOT USED
  - 7 NOT USED
  - 8 2X6 BLOCKING W/16d AT MAX. 12" O.C.
  - 9 MIN. 5/8" PLYWOOD SKIRTING W/10d BOX @ MIN. 4" O.C. AT ENDWALLS & 6" O.C. AT SIDEWALLS E.N. & TYP. 12" O.C. FN.
  - 10 ADD BLOCKING OR SHIMS AS REQ. TO MAX. HT. SEE DETAIL #2
  - 11 MIN. FOUNDATION HEIGHT. SEE DETAIL #2
  - 12 10 GA. PLATE 4" X 12"
  - 13 2X8 BLOCKING FACE OR TOE NAIL 16d AT MAX. 12" O.C. ADD BLKS. OR SHIMS AS REQ'D
  - 14 FLOOR FRAME BEAM. SEE STRUCTURAL
  - 15 VENT MIN. 3" X 6'-6" TYP. 4-PLACES = 6.5 SF. 2 VENTS AT 3" X 2'-0" = 1.0 SF. = 7.5 SQ. FT. TOTAL
  - 16 SILL RESTRAINT 1" DIA. PIPE. SEE FOUND. PLAN FOR LOCATION - 24" LONG
  - 17 FINISH GRADE
  - 18 EXTERIOR FINISH
  - 19 PLYWOOD SUBFLOOR
  - 20 MOD-LINE
  - 21 FLOOR-JOIST
  - 22 EN SEE NOTE #9
  - 23 6" X 12" X 10GA. PLATE W/(4) #10 SMS TO FLR. & (4) 1/4" DIA. X 3" LAG TO FOUND. TOP PLATE
  - 24 6" X 12" X 10 GA. PLATE
  - 25 1/4" DIA. X 3" LG. LAG SCREW TYP. 4-PLACES
  - 26 #10 S.T.S. TYP. 4-PLACES
  - 27 2" X 12" X 2'-6" SILL PLATE. SEE FOUND. PLAN FOR QUANTITY REQ'D
  - 28 2X8 BLOCKING W/16d AT MAX. 6" O.C. MIN. 3 PER BLOCK. (MAY VARY ACCORDING TO SITE)
  - 29 10d GALV. BOX NAIL AT MAX. 4" O.C.
  - 30 INSERT REQ'D 2X4 BLOCKING OR PLYWOOD SHIM W/16d AT 12" O.C. FACE NAIL
  - 31 NOT USED
  - 32 NOT USED

IDENTIFICATION STAMP  
DIV. OF THE STATE ARCHITECT  
OFFICE OF REGULATION SERVICES  
04 101984  
AC FLS SS  
DATE MAR 09 2000

IDENTIFICATION STAMP  
DIV. OF THE STATE ARCHITECT  
APPROX 115000  
AC FLS SS  
DATE 7/24/14

REVISIONS	Electrical Engineer's Seal	Mechanical Engineer's Seal	Structural Engineer's Seal	Architect's Seal

Electrical Engineer's Seal

Mechanical Engineer's Seal

Structural Engineer's Seal

Architect's Seal

IDENTIFICATION STAMP  
DIV. OF THE STATE ARCHITECT  
OFFICE OF REGULATION SERVICES  
PC-04  
10419  
AC FLS SS  
DATE OCT 24 1999

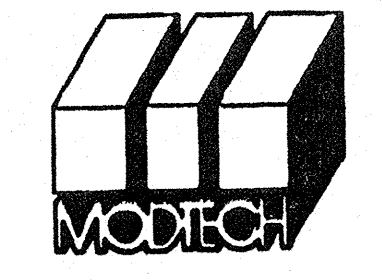

**MODTECH INC.**  
2830 BARRETT AVENUE  
PERRIS, CALIF. 92572  
PH (909) 943-4014  
FAX (909) 940-0427

PROJECT NUMBER:

© MODTECH, INC. 1999

DRAWN BY:  
DATE:  
CHECKED BY: SS  
DATE: 10/22/17  
MODTECH Index No.

**FOUNDATION DETAILS**

**F2.0**

FILE PATH: 2440-0-F2-0.DWG PROJECT NO. PC-04-101419

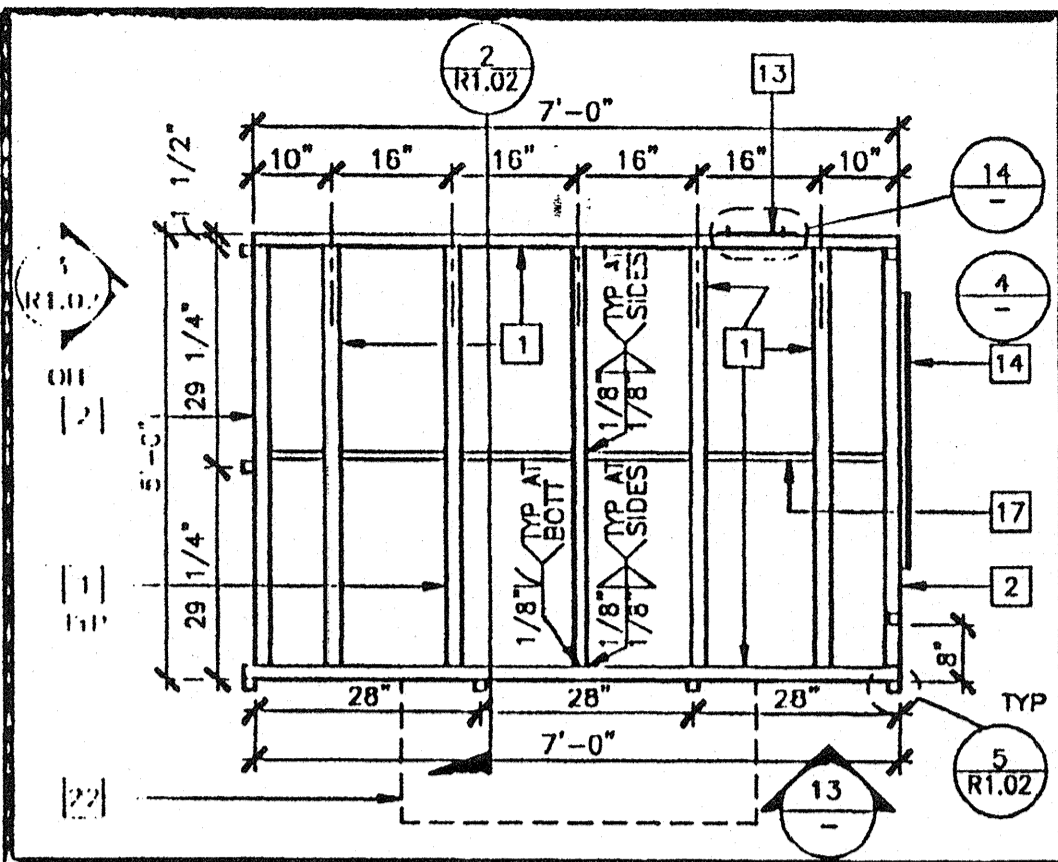

SCALE: NTS

LANDING FRAME 12

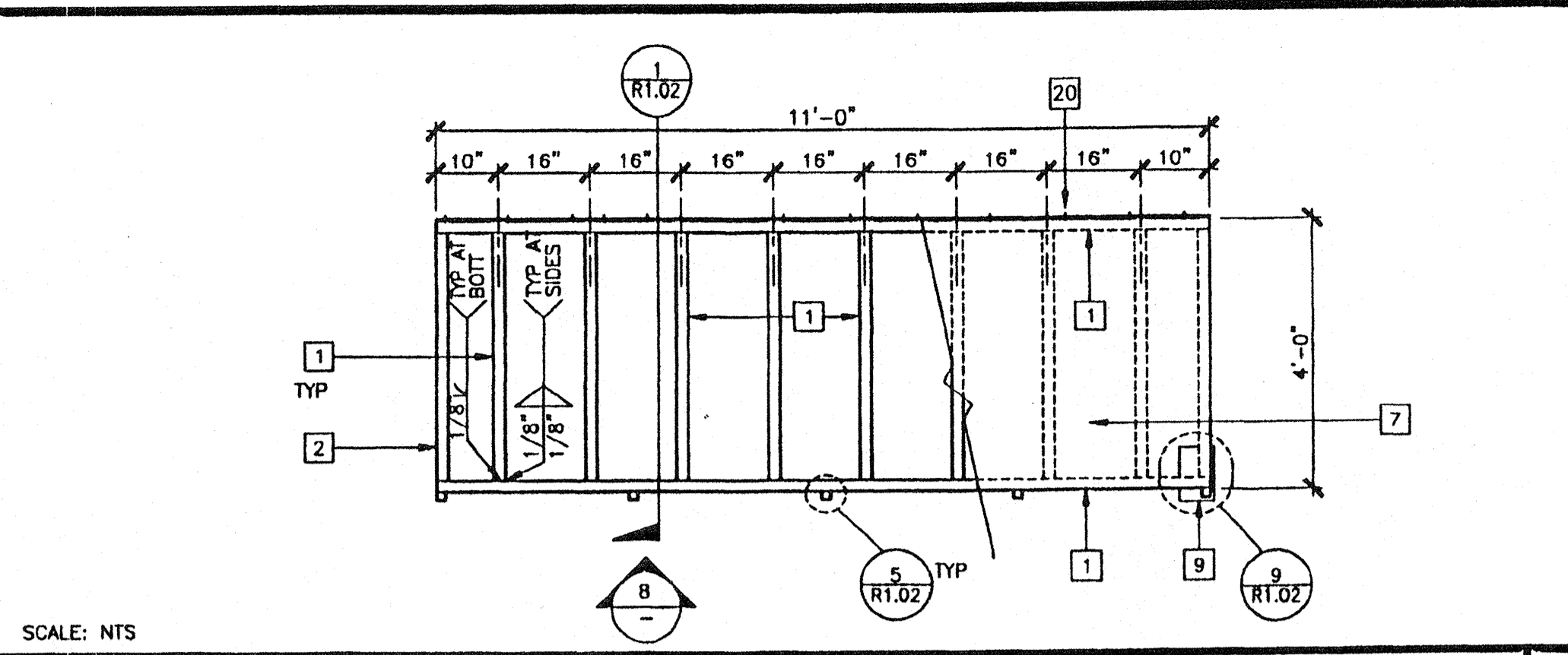

SCALE: NTS

RAMP FRAME 7

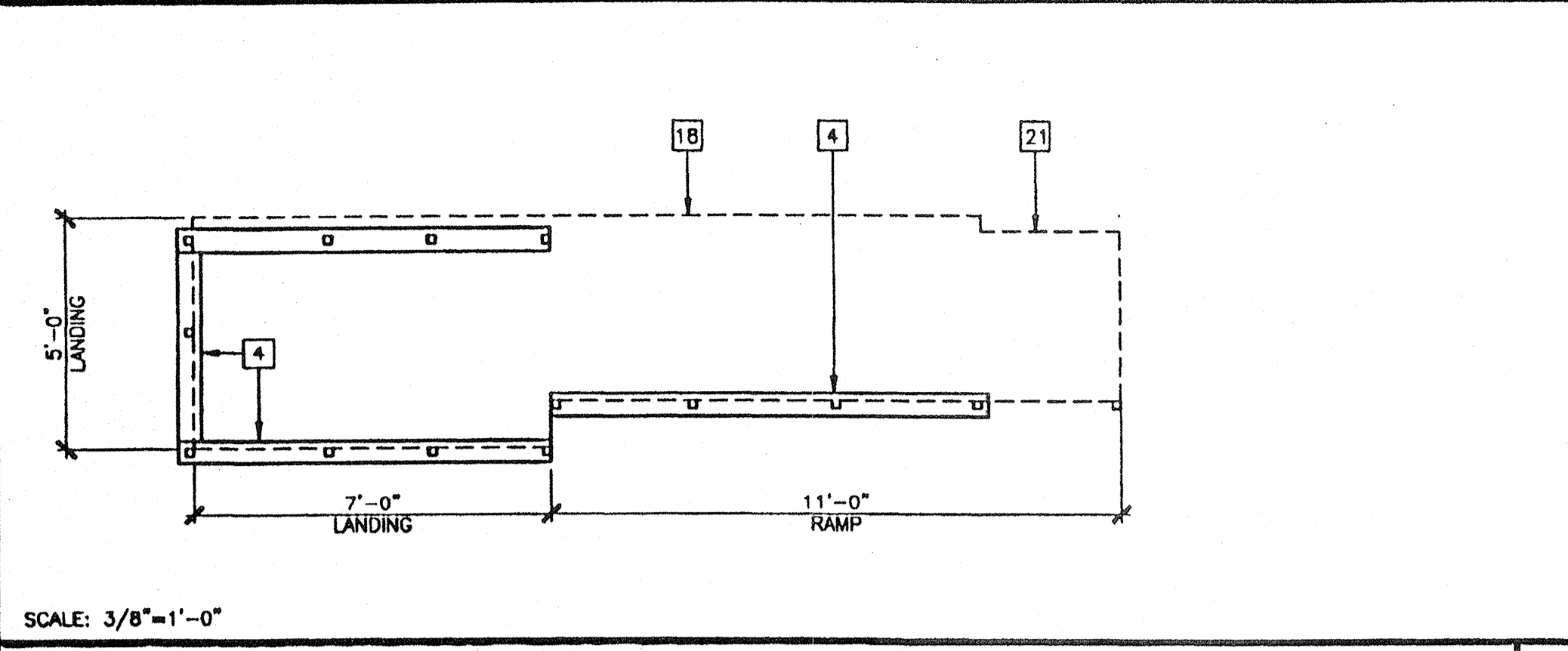

SCALE: 3/8"=1'-0"

SILL PLAN FOR RAMP AND LANDING 1

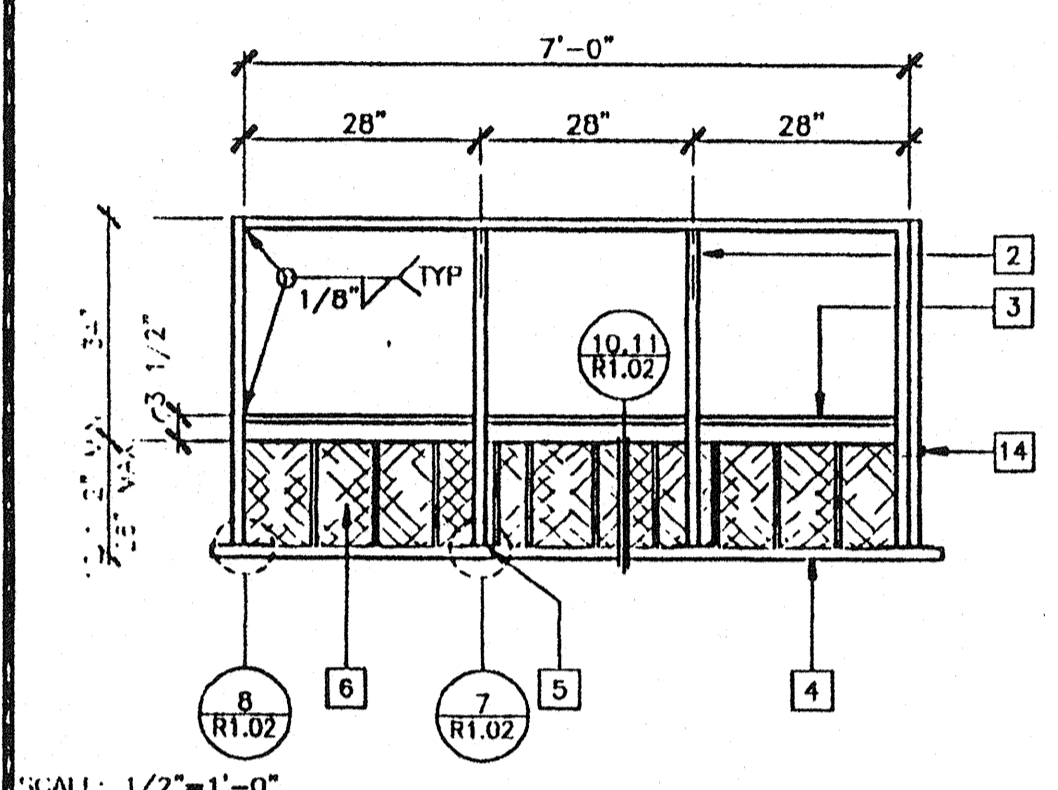

SCALE: 1/2"=1'-0"

LANDING ELEVATION 13

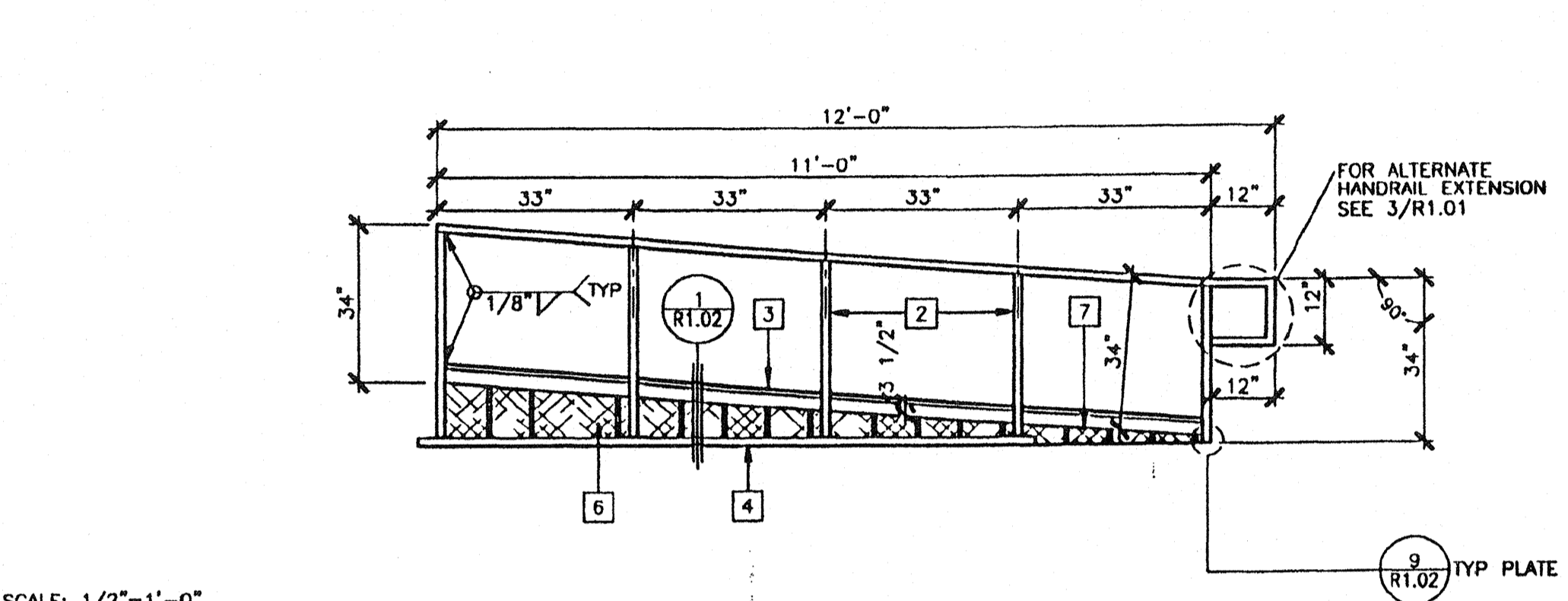

SCALE: 1/2"=1'-0"

RAMP ELEVATION 8

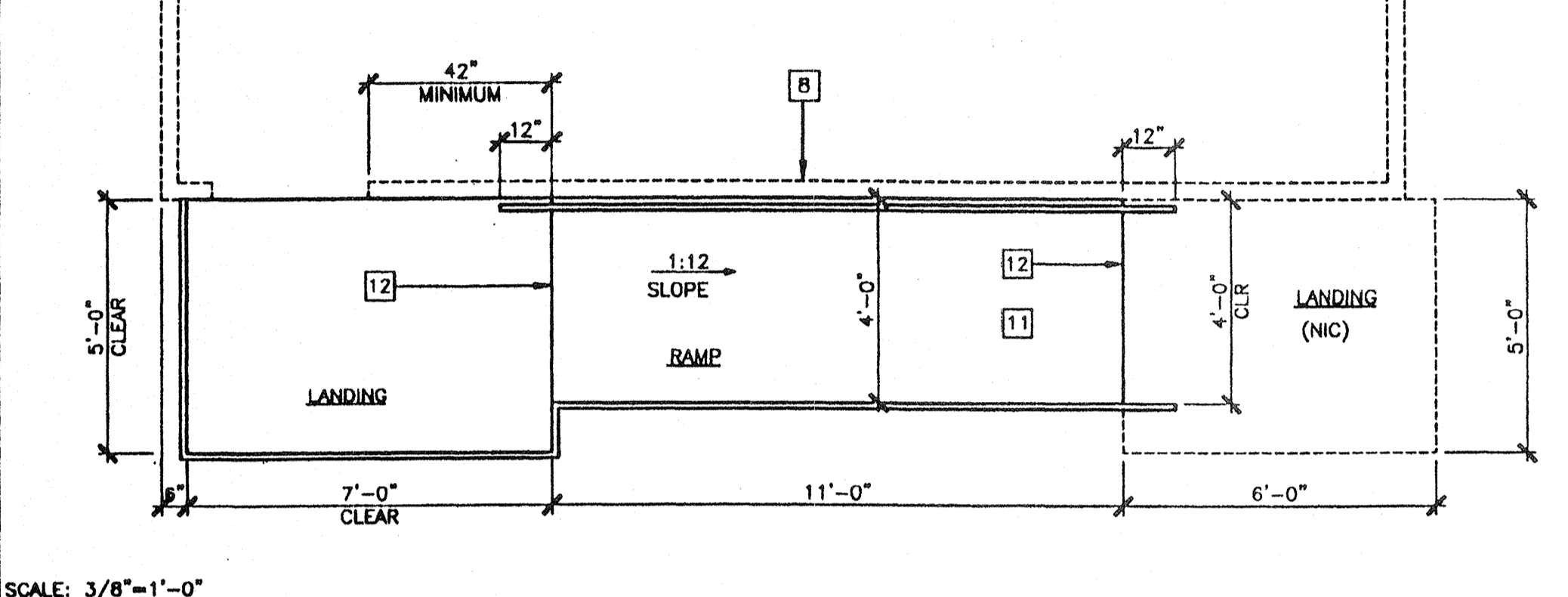

SCALE: 3/8"=1'-0"

RAMP AND LANDING AT BUILDING 2

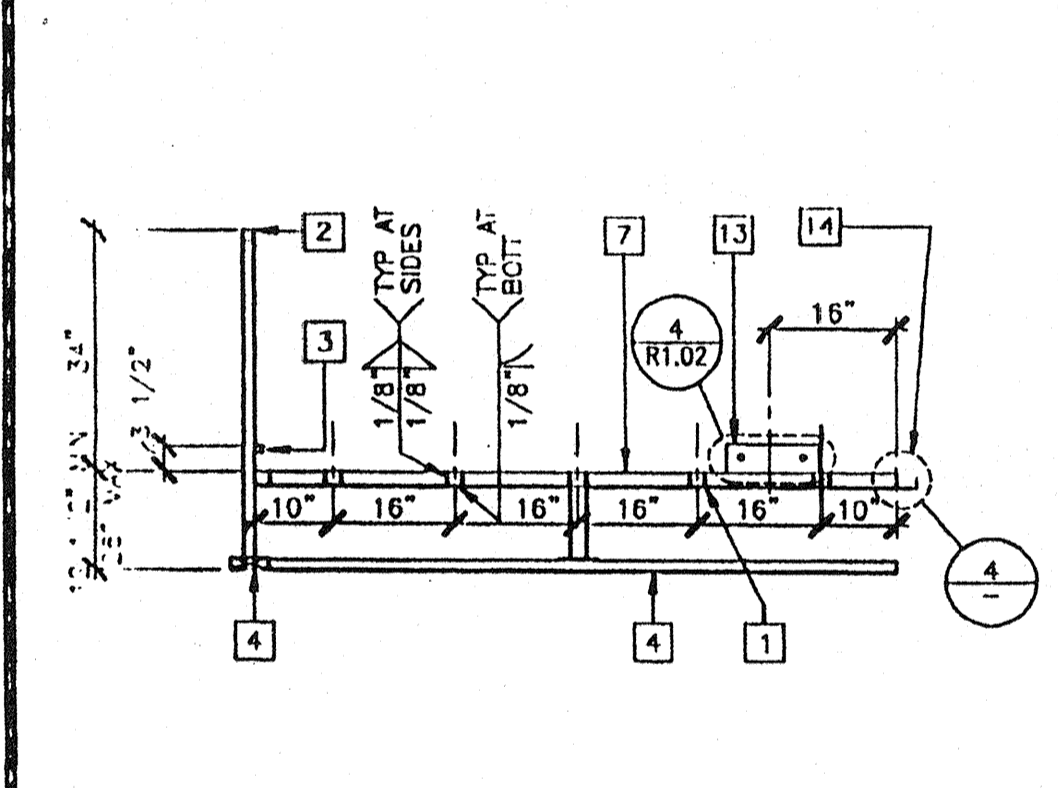

SCALE: NTS

SECTION AT LANDING 14

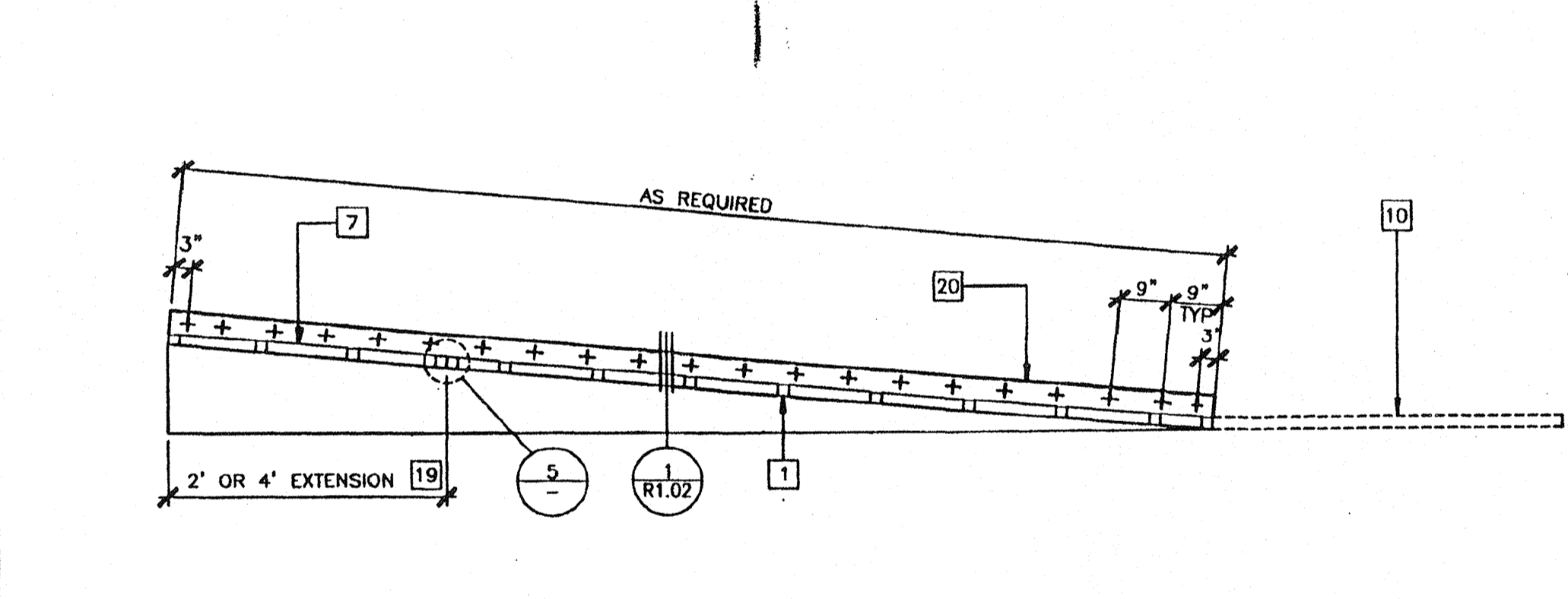

SCALE: NTS

LONGITUDINAL SECTION AT RAMP 9

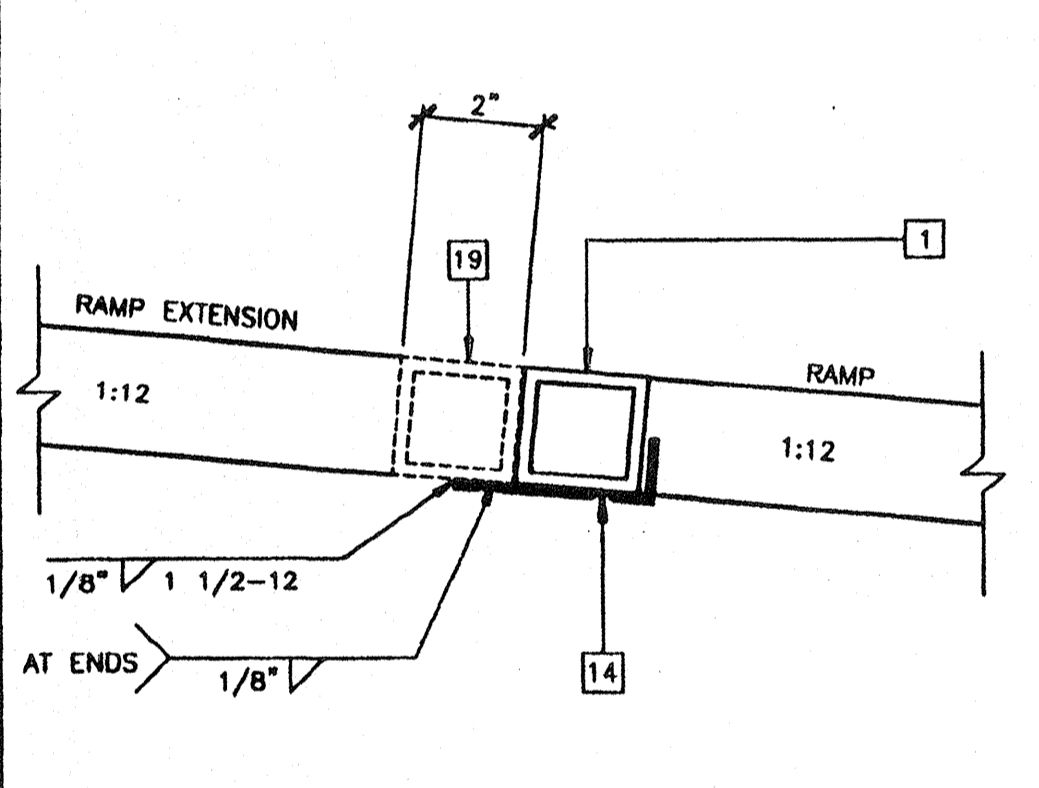

SCALE: NTS

RAMP EXTENSION TO RAMP 5

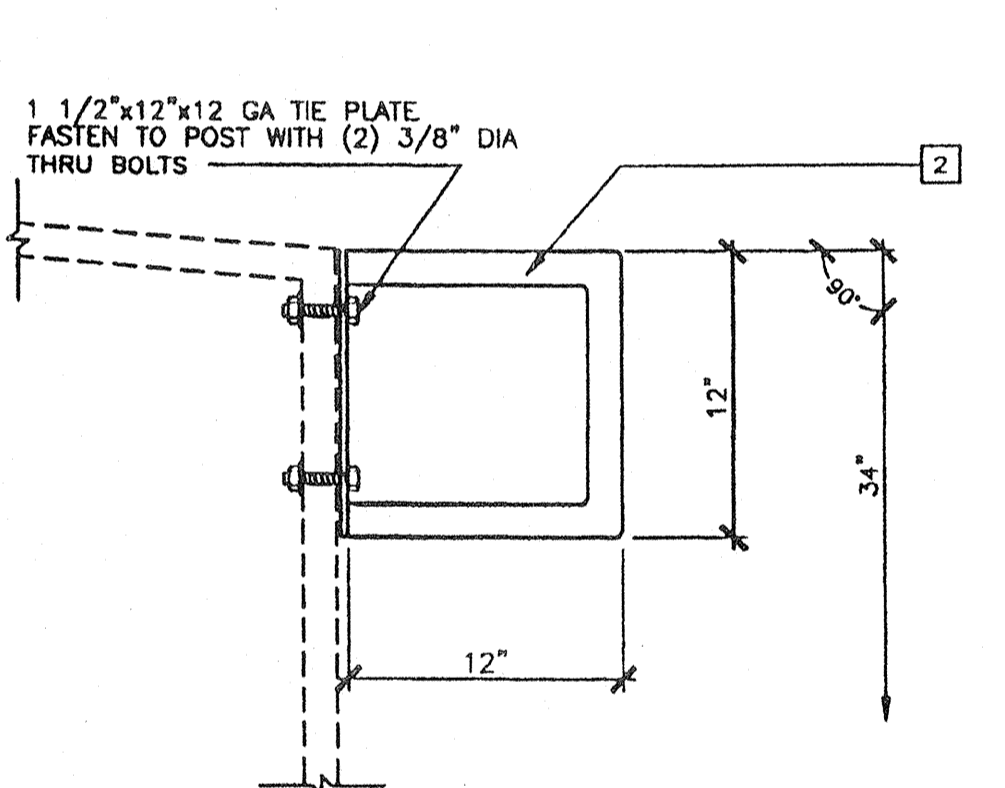

ALTERNATE GUARD RAIL EXTENSION 3

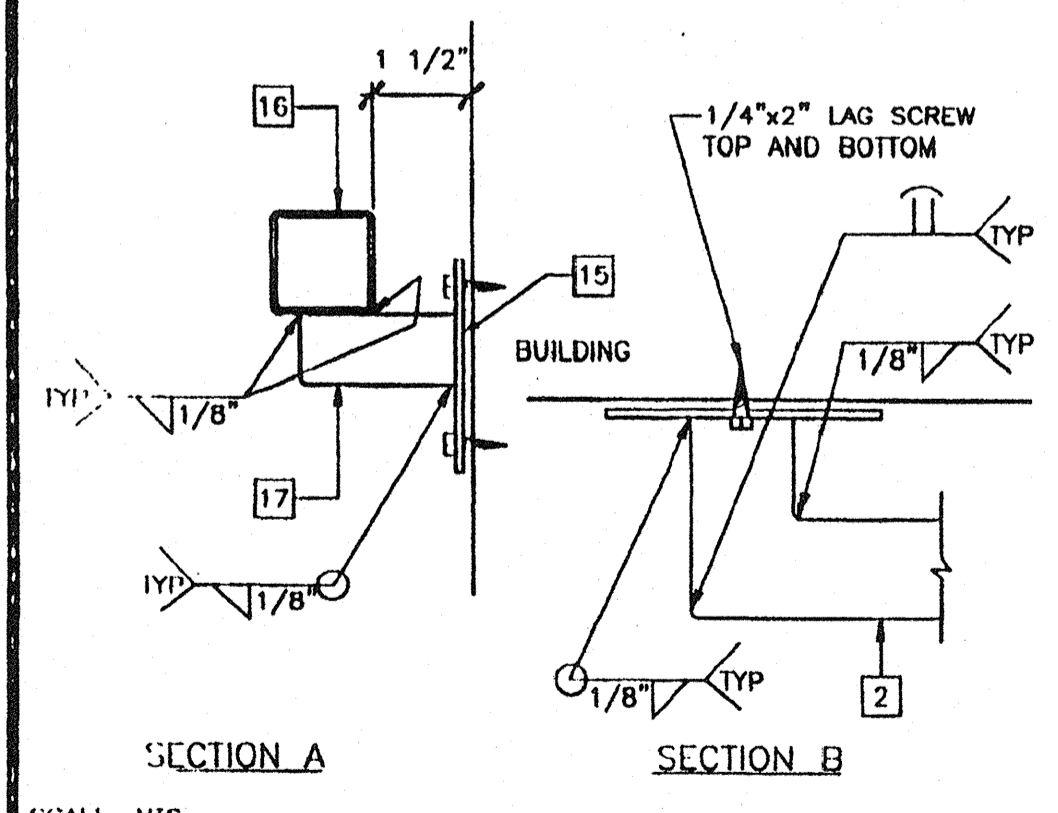

SCALE: NTS

HANDRAIL CONNECTION 15

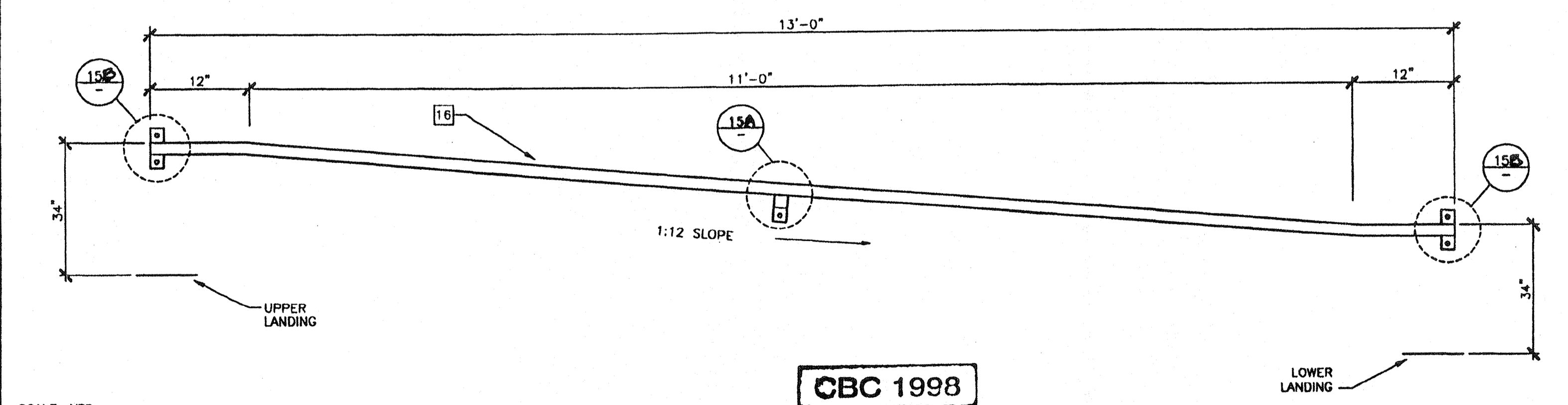

SCALE: NTS

HANDRAIL ATTACHED TO BUILDING (OPTIONAL) 6

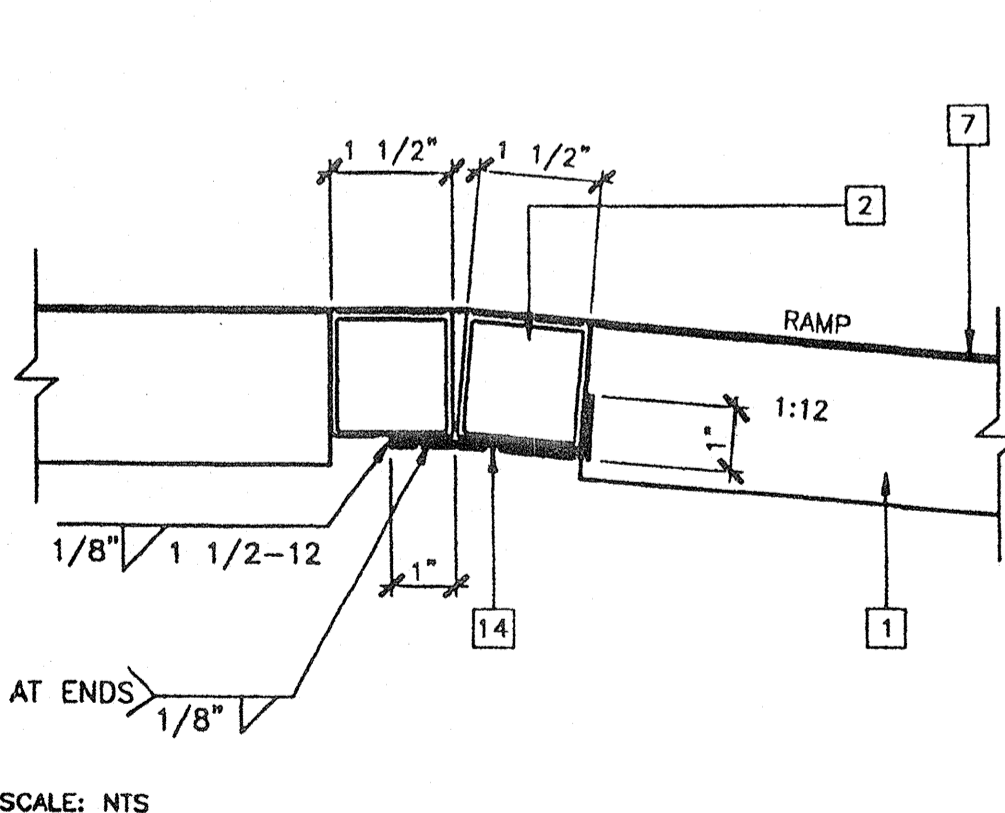

SCALE: NTS

RAMP AT LANDING 4

- KEY NOTES**
- 1 TS 2"x2"x14 GA
  - 2 TS 1 1/2"x1 1/2"x14 GA (Fy = 39KSI). ROUNDED OR BEVELLED AT CORNERS
  - 3 TS 1"x1"x16 GA WITH CHAIR GUILD
  - 4 2"x6" PRESSURE TREATED SILL PLATE
  - 5 2"x4"x12 GA BASE PLATE WITH (2) 1/4"x1" LAGS
  - 6 SKIRTING: PLYWOOD TO MATCH BUILDING SIDING. BLOCK ALL EDGES. ATTACH WITH #8 AT 6" OC EDGES AND 12" OC FIELD. AT EDGE CONNECTION TO TUBE STEEL USE #14x2" TEK SCREWS AT 6" OC
  - 7 12 GA METAL DECK: NON-SLIP SURFACE. DESIGN COEFFICIENT OF FRICTION GREATER THAN 6%. MAINTAINABLE FOR 1 YEAR EXISTING BUILDING
  - 8 6"x10"x12 GA BASE PLATE AT RAMP TOI
  - 9 LOWER LANDING BY DISTRICT
  - 10 RAMP BY MODTECH
  - 11 FLUSH TRANSITION
  - 12 6"x12"x10 GA PLATE WITH (2) 1/4"x3" LAGS TO STRUCTURAL FRAME OF BUILDING
  - 13 3"x1"x3'-0"x10 GA BENT PLATE
  - 14 2"x4"x 1/8" PLATE
  - 15 TS 1 1/2"x1 1/2"x14 GA HANDRAIL - CONTINUOUS AND UNINTERRUPTED. ROUNDED OR BEVELLED AT CORNERS
  - 16 TS 1"x1"x16 GA RAIL SUPPORT
  - 17 LINE OF RAMP/LANDING ABOVE
  - 18 RAMP EXTENSION FRAME
  - 19 6"x10 GA CONTINUOUS PLATE WITH 1/4"x2" ILK SCREWS AT 9" OC INTO WOOD OR FOUNDATION BLOCKS OR #14x2" TEK SCREWS INTO STEEL AT 9" OC
  - 20 NOTCH BOTTOM PLATE (MUD SILL) AS REQUIRED TO CLEAR RAMP TOE. MAX NOTCH 1 1/2"x4'-0" LONG.
  - 21 NOTCH BOTTOM PLATE (MUD SILL) AS REQUIRED TO CLEAR RAMP TOE. MAX NOTCH 1 1/2"x4'-0" LONG.
  - 22 LINE OF STAIR OPTION - 12,13/R1.02

IDENTIFICATION STAMP  
DIV OF THE STATE ARCHITECT  
OFFICE OF REGULATION SERVICES  
APPROX 1115800  
AC [Signature] PLS [Signature] SS [Signature] TB  
DATE 7/29/14

IDENTIFICATION STAMP  
DIV OF THE STATE ARCHITECT  
OFFICE OF REGULATION SERVICES  
APPROX 1115800  
AC [Signature] PLS [Signature] SS [Signature] TB  
DATE MAR 09 2000

- NOTES**
1. RAMP: RAMP SHALL NOT SLOPE MORE THAN 1" IN 12"
  2. HANDRAILS: HANDRAILS AT BOTH SIDES OF RAMP AT 34" HIGH.
  3. SURFACE: LANDING & RAMP TO HAVE NON-SLIP SURFACE AMCOR GRIP II AS MANUFACTURED BY AMERICAN CHEMICAL COMPANY (OR EQUAL)
  4. GROUNDING: PROVIDE GROUNDING OF RAMP TO BUILDING FRAME WITH #8 COPPER TO BOTH GROUND LUGS.
  5. ARCHITECT SITE/RAMP/LANDING PLANNING: DUE TO VARYING SITE CONDITIONS THE MAXIMUM HEIGHT OF FINISH FLOOR FROM GRADE IS 26". THEREFORE IT IS POSSIBLE THAT THE ACCESS RAMP ATTACHED TO THE BUILDING COULD BE 26'-0" AT A SLOPE OF 1:12. ARCHITECT MUST TAKE INTO ACCOUNT THAT THE RAMP SUPPLIED BY MODTECH INC. IS 11'-0" AT A SLOPE OF 1:12. THEREFORE THE ARCHITECT WILL HAVE TO DESIGN AND PROVIDE DETAILS OF RAMP EXTENSIONS AND BOTTOM LANDING DEPENDING ON PARTICULAR SITE CONDITIONS. IN NO WAY IS MODTECH INC RESPONSIBLE FOR ANY RAMP EXTENSION EXCEEDING THE ORIGINAL PLAN AS SHOWN ON THIS SHEET
  6. ALL 1 1/4" AND 1 1/2" TUBE STEEL TO BE IN ASTM A500 GRADE A STEEL (Fy = 39 KSI)

**REVISIONS**

1			
2			
3			
4			

Electrical Engineer's Seal  
Mechanical Engineer's Seal  
Architect's Seal

**CBC 1998**

IDENTIFICATION STAMP  
DIV. OF THE STATE ARCHITECT  
OFFICE OF REGULATION SERVICES  
PC-04  
101419  
DATE OCT 25 1999

**MODTECH INC.**  
2830 BARRETT AVENUE  
PERRIS, CALIF. 92572  
PH (909) 943-4014  
FAX (909) 940-0427

PROJECT NUMBER: \_\_\_\_\_  
DATE: \_\_\_\_\_  
CHECKED BY: SS  
DATE: 10/22/99  
MODTECH Index No. \_\_\_\_\_

© MODTECH, INC. 1999

**RAMP/LANDING 11' RAMP**

**R1.00**

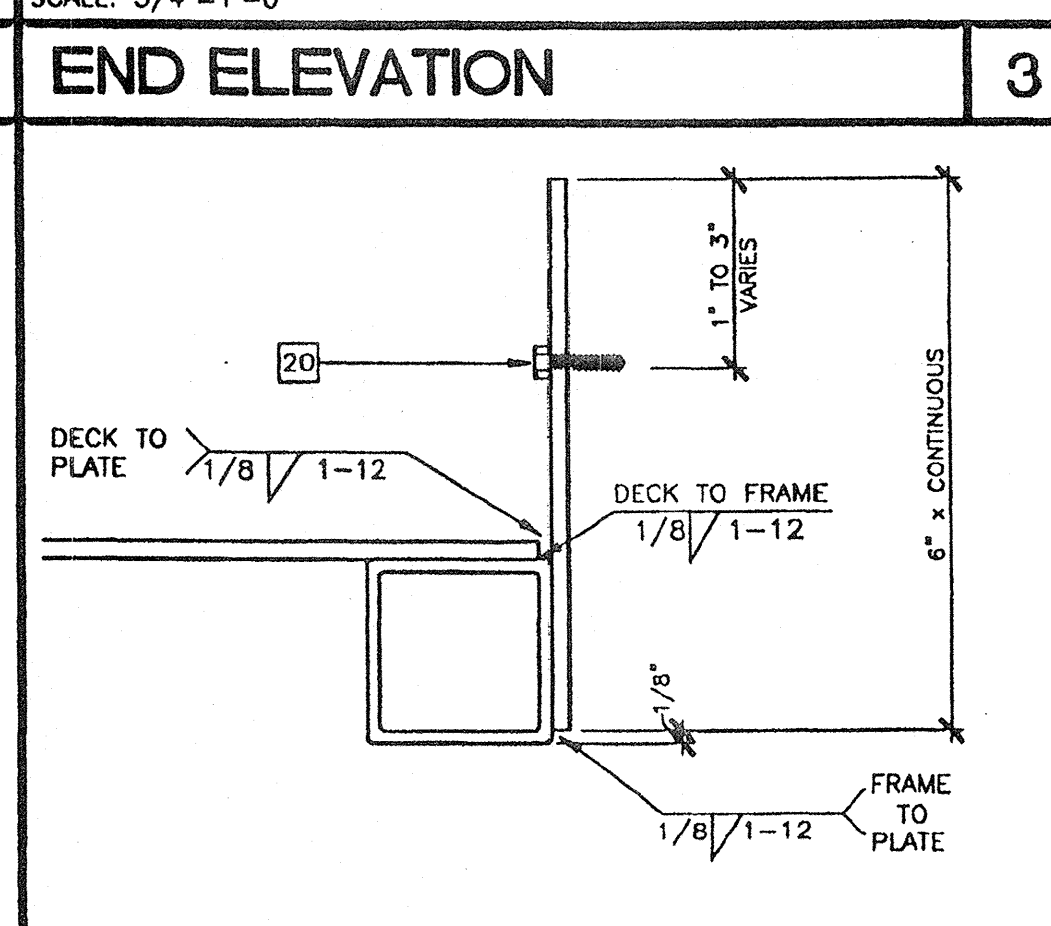
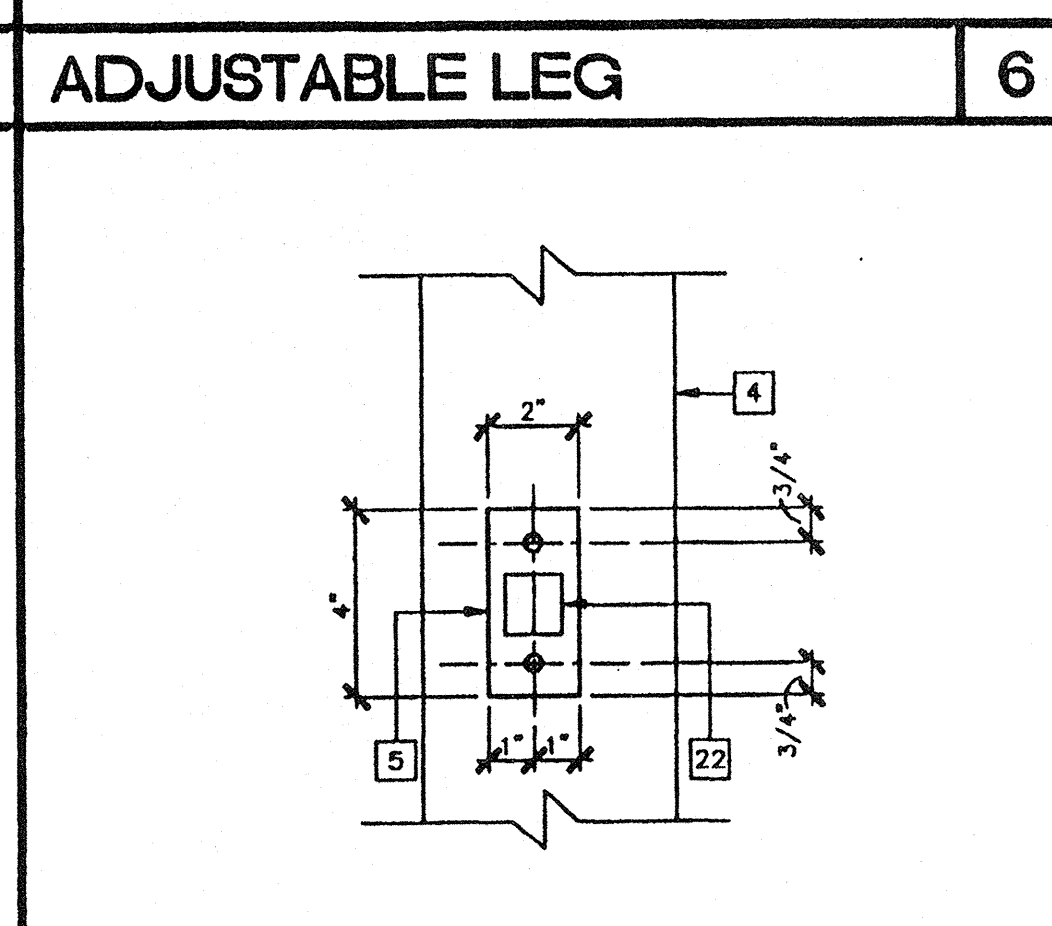
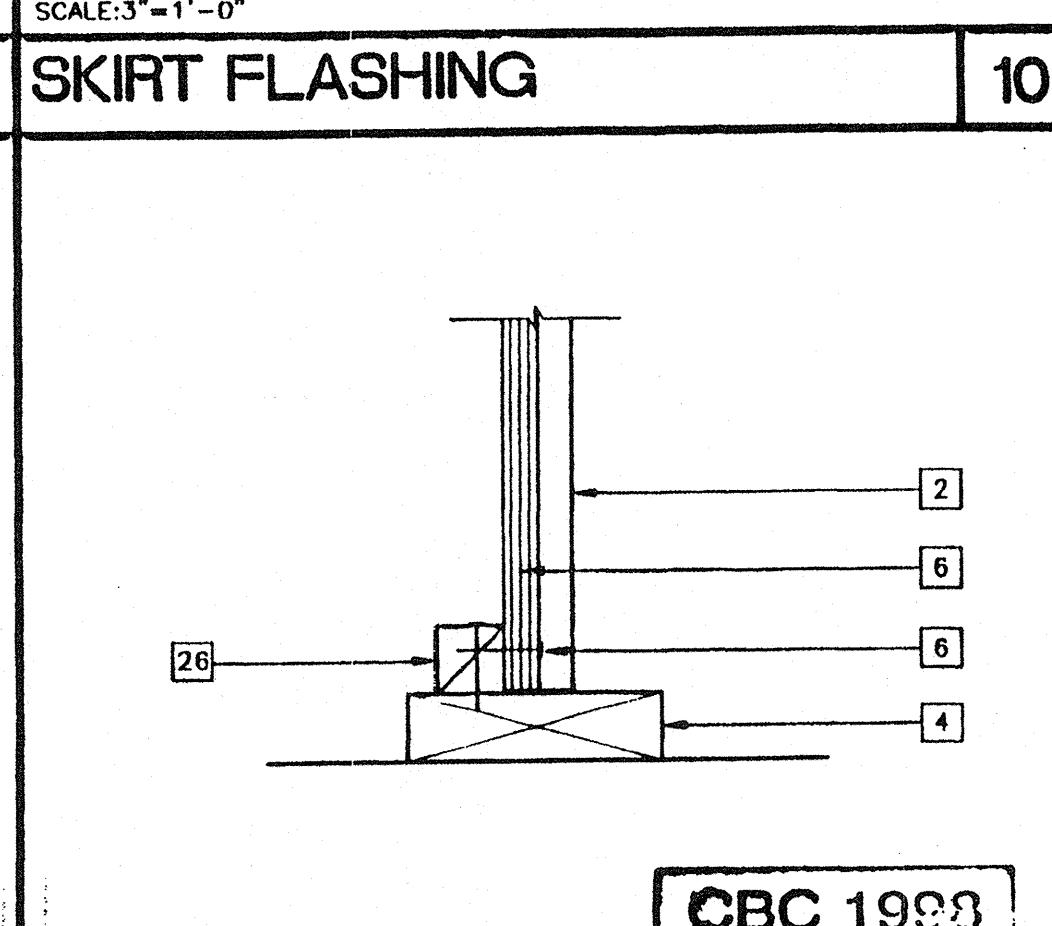
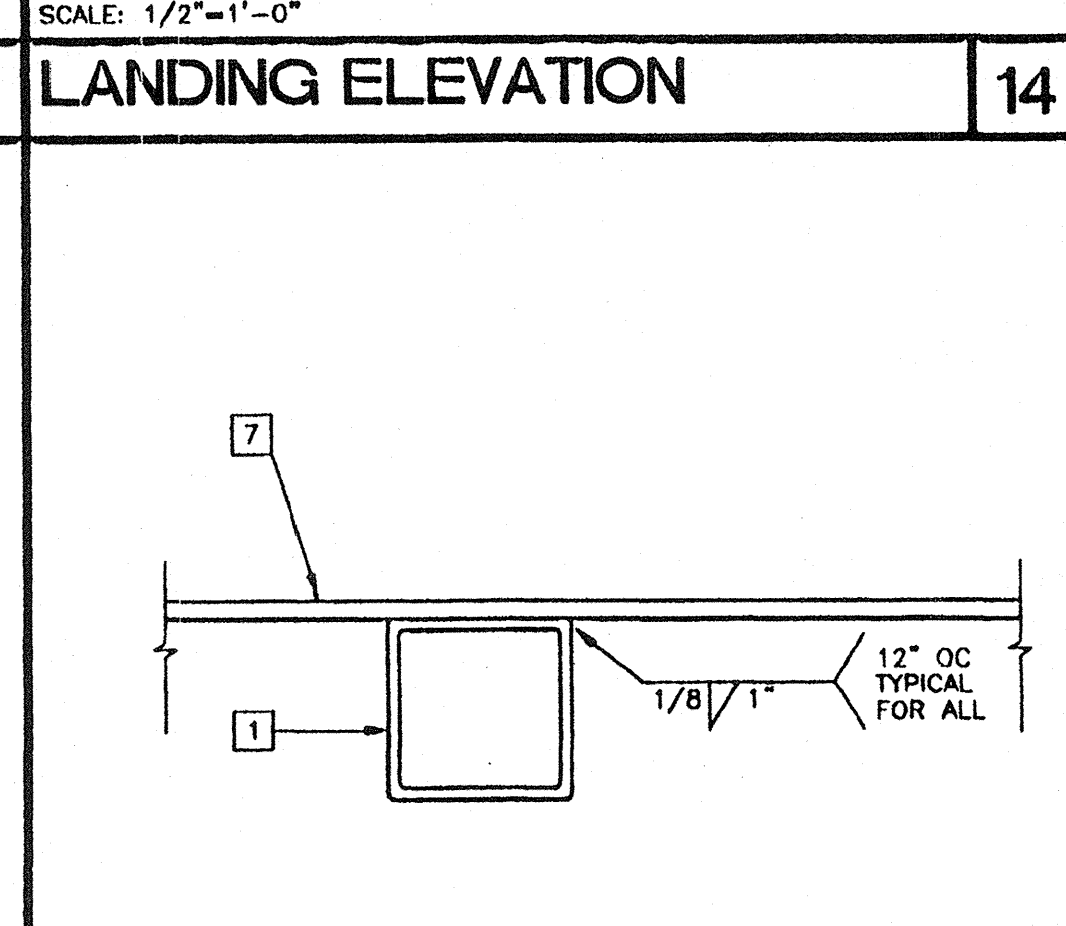
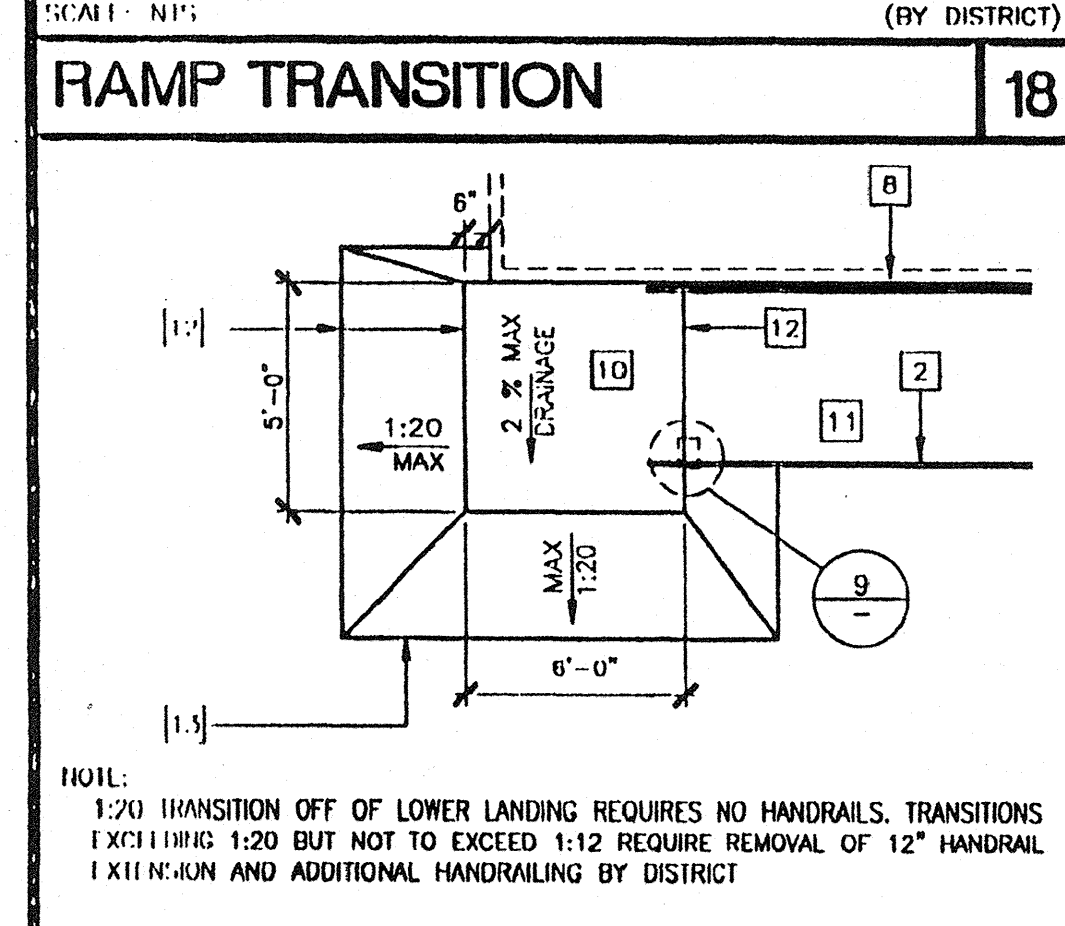
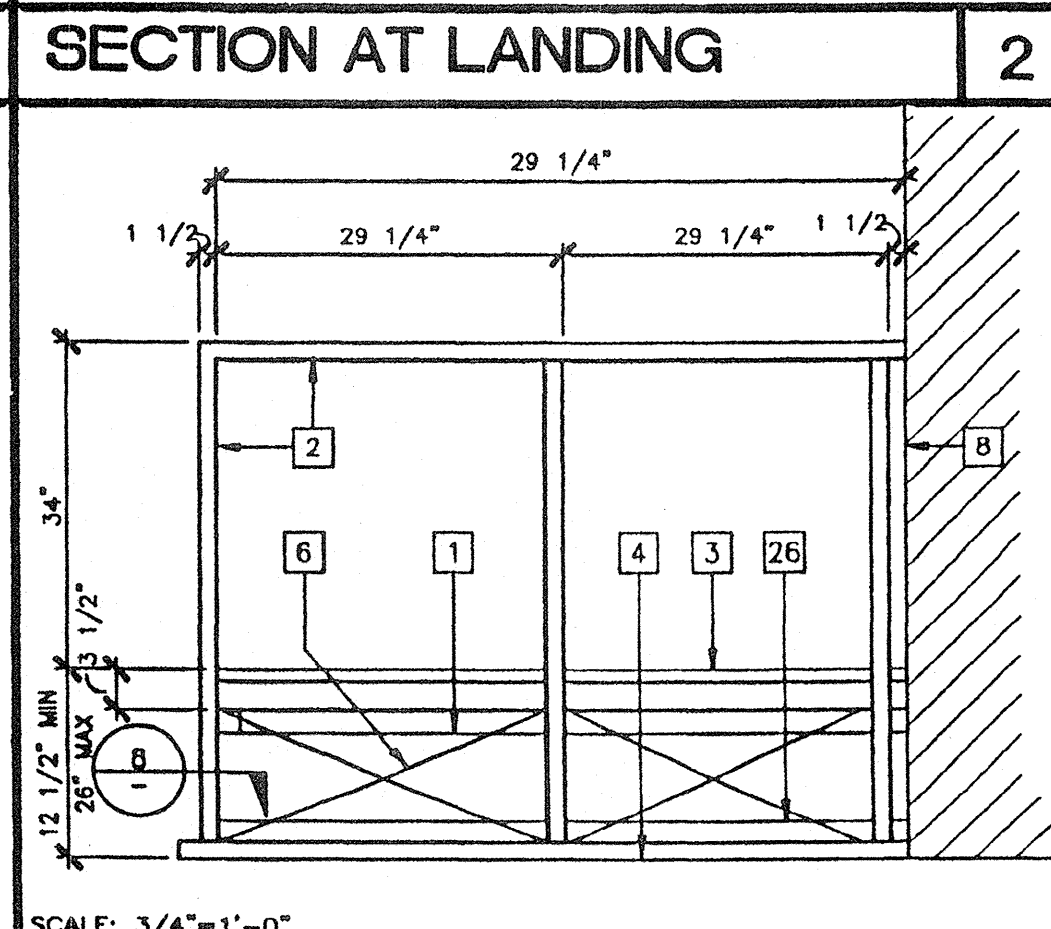
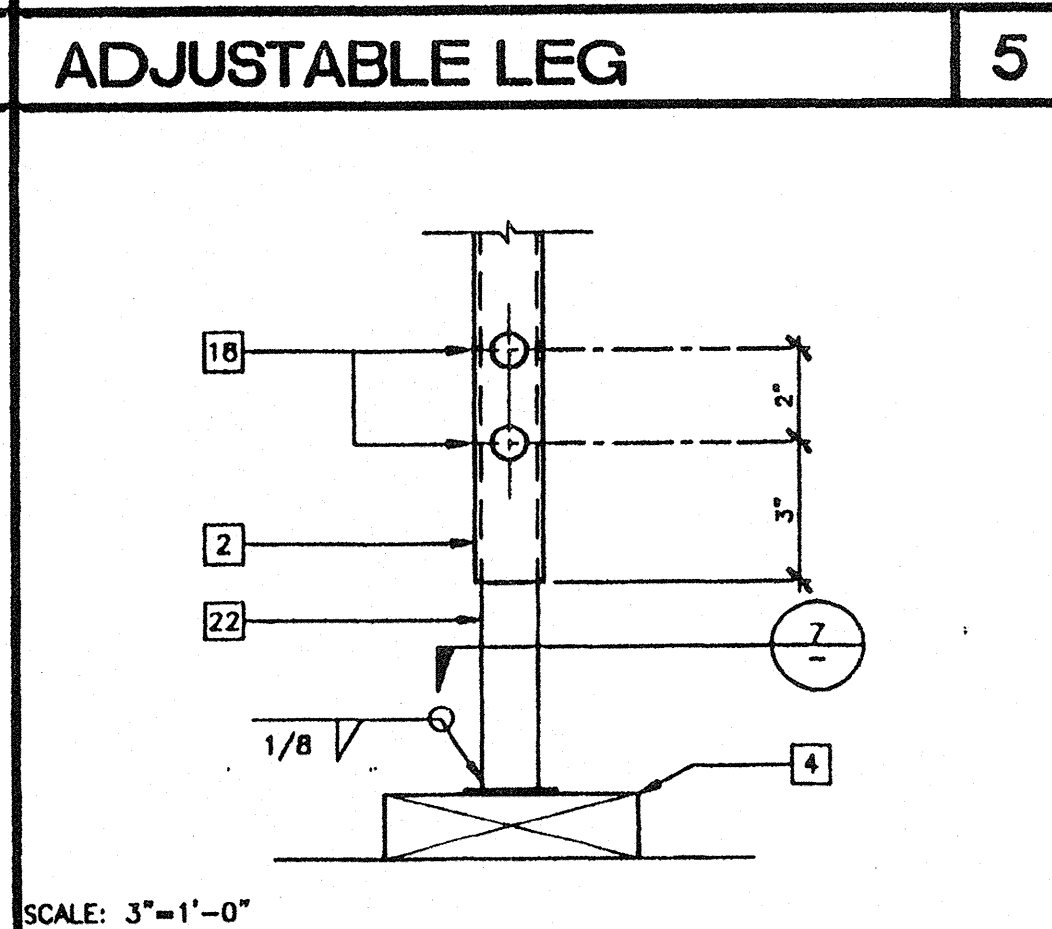
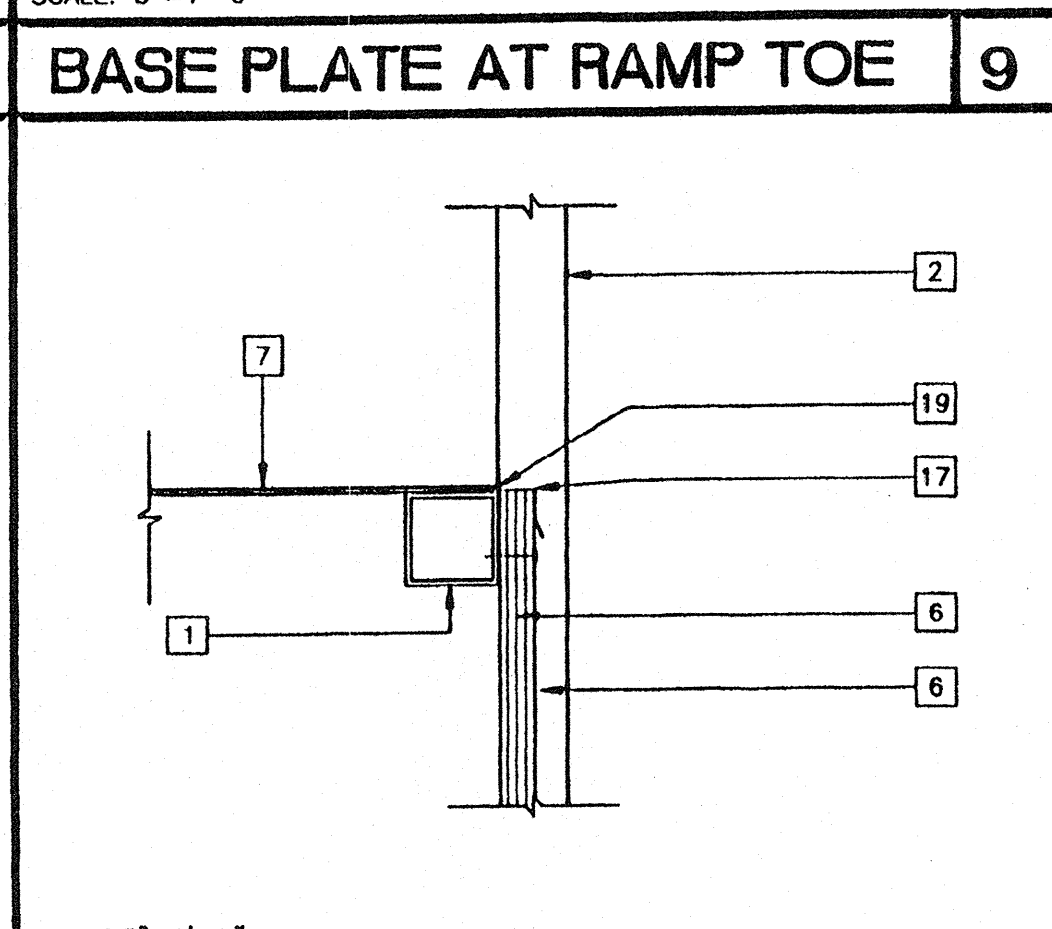
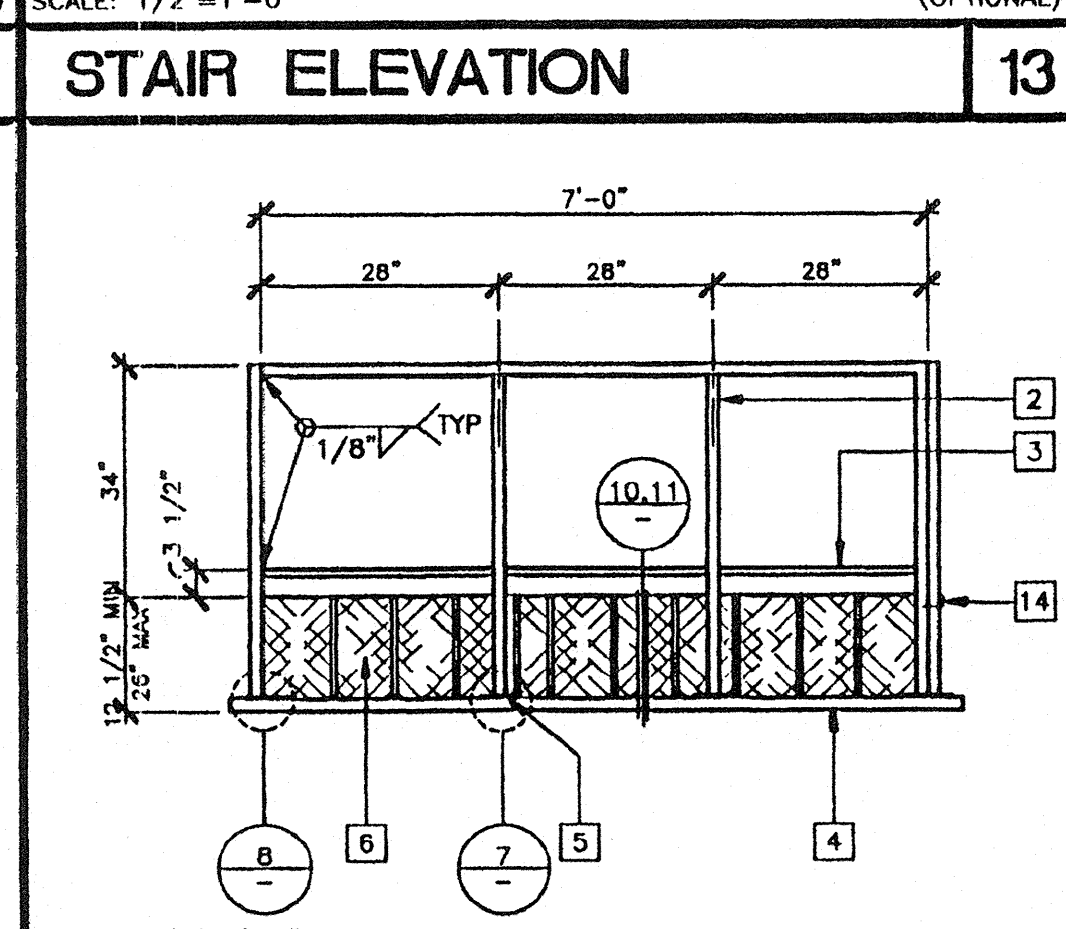
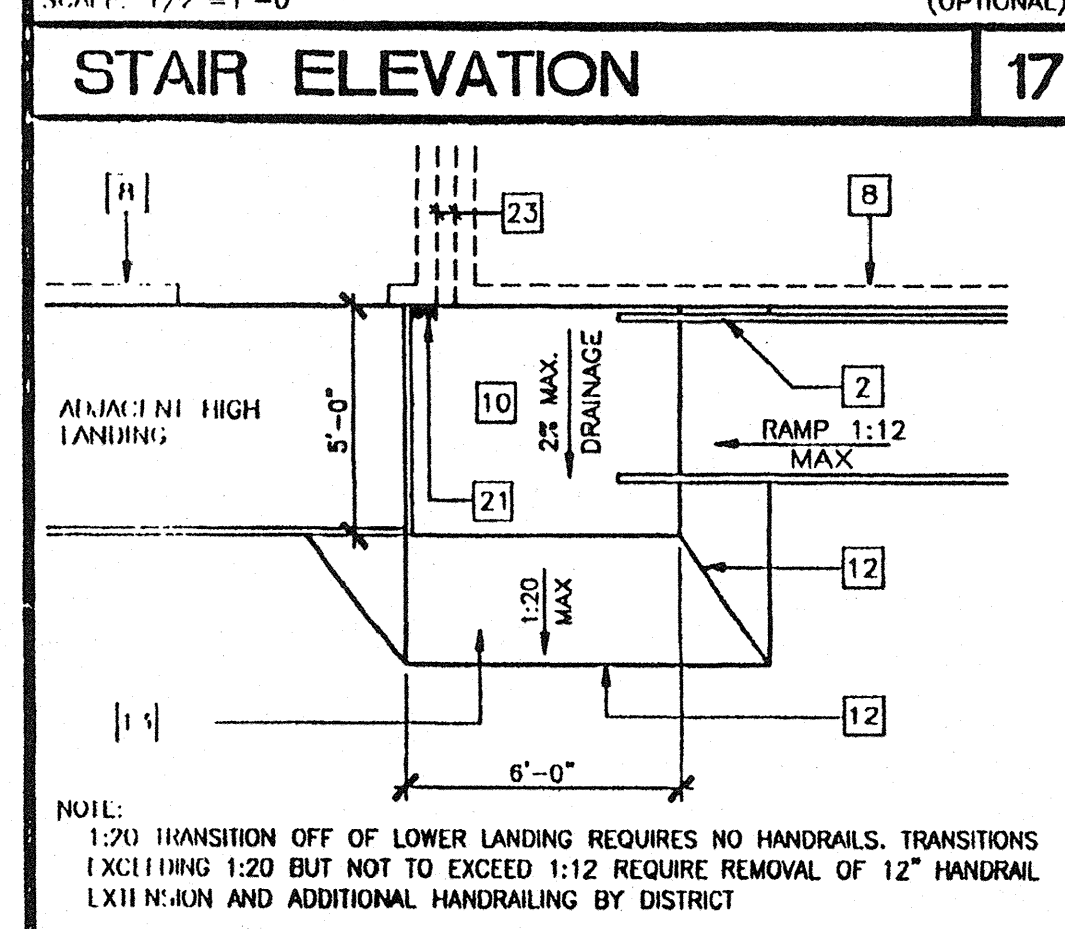
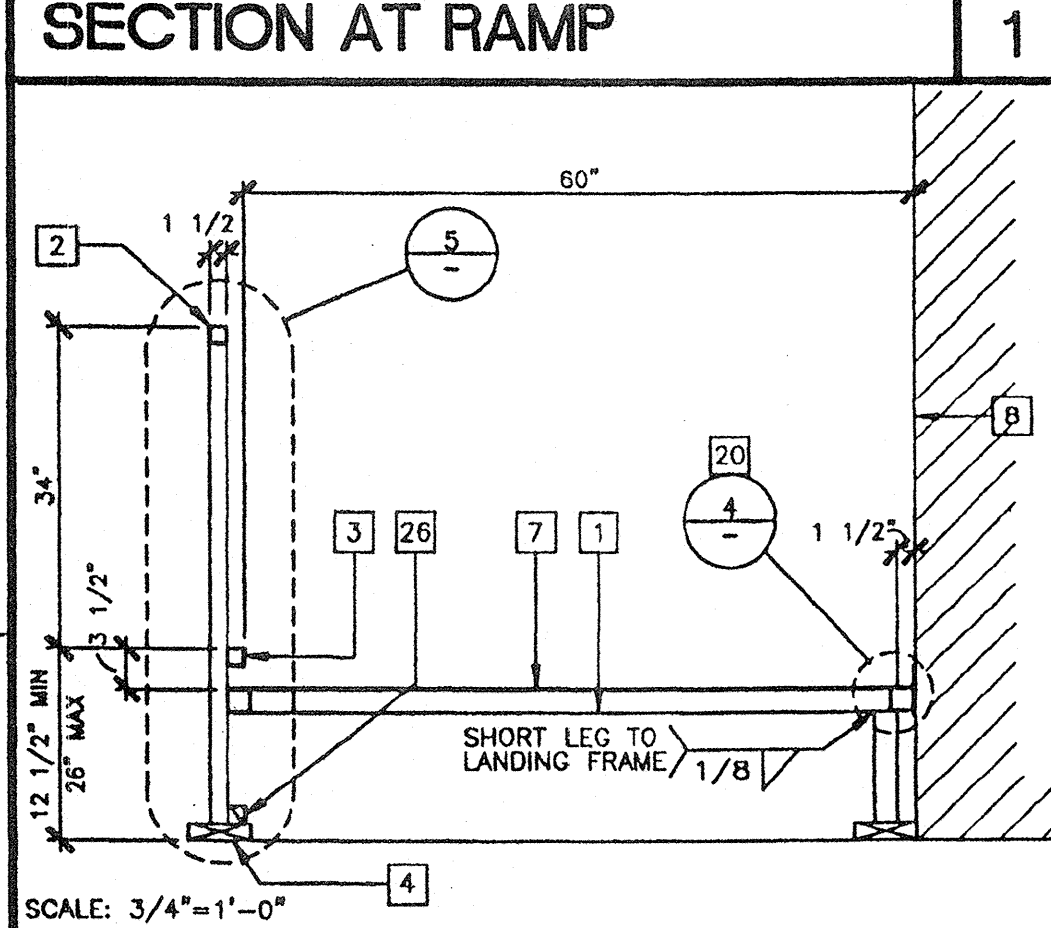
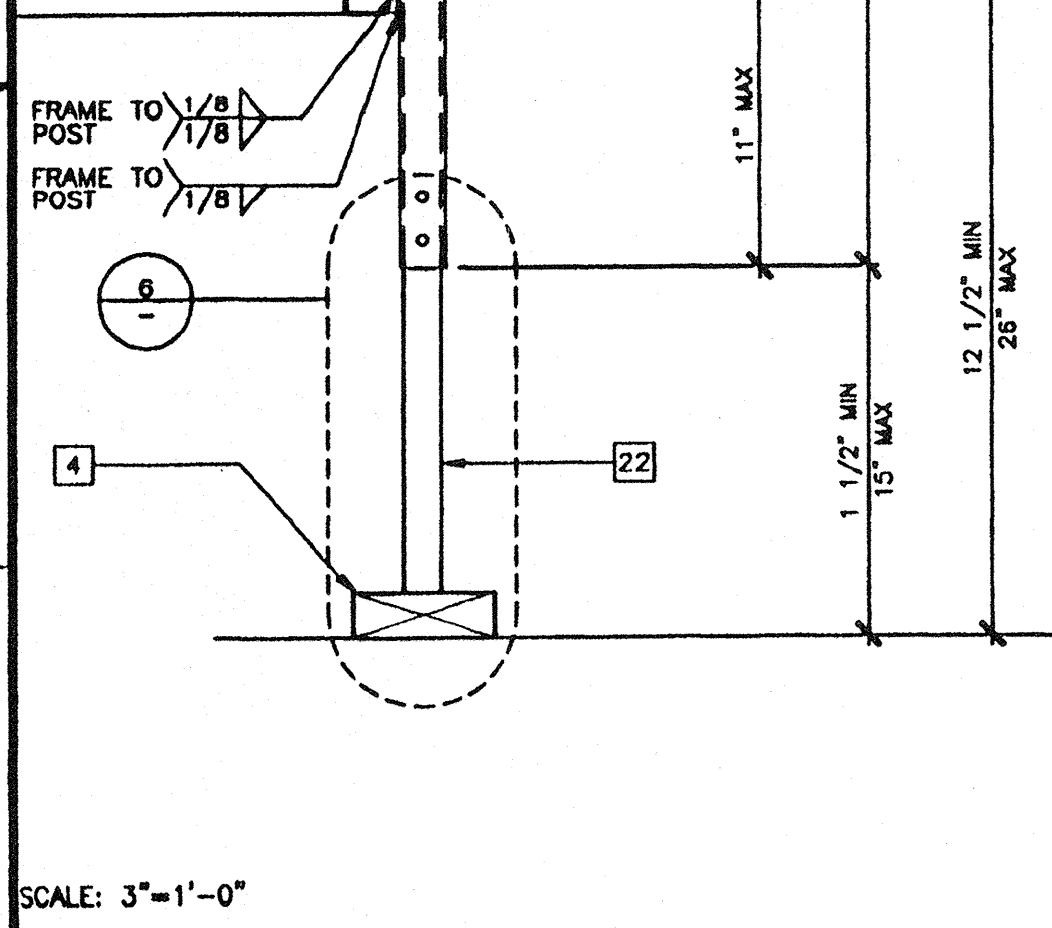
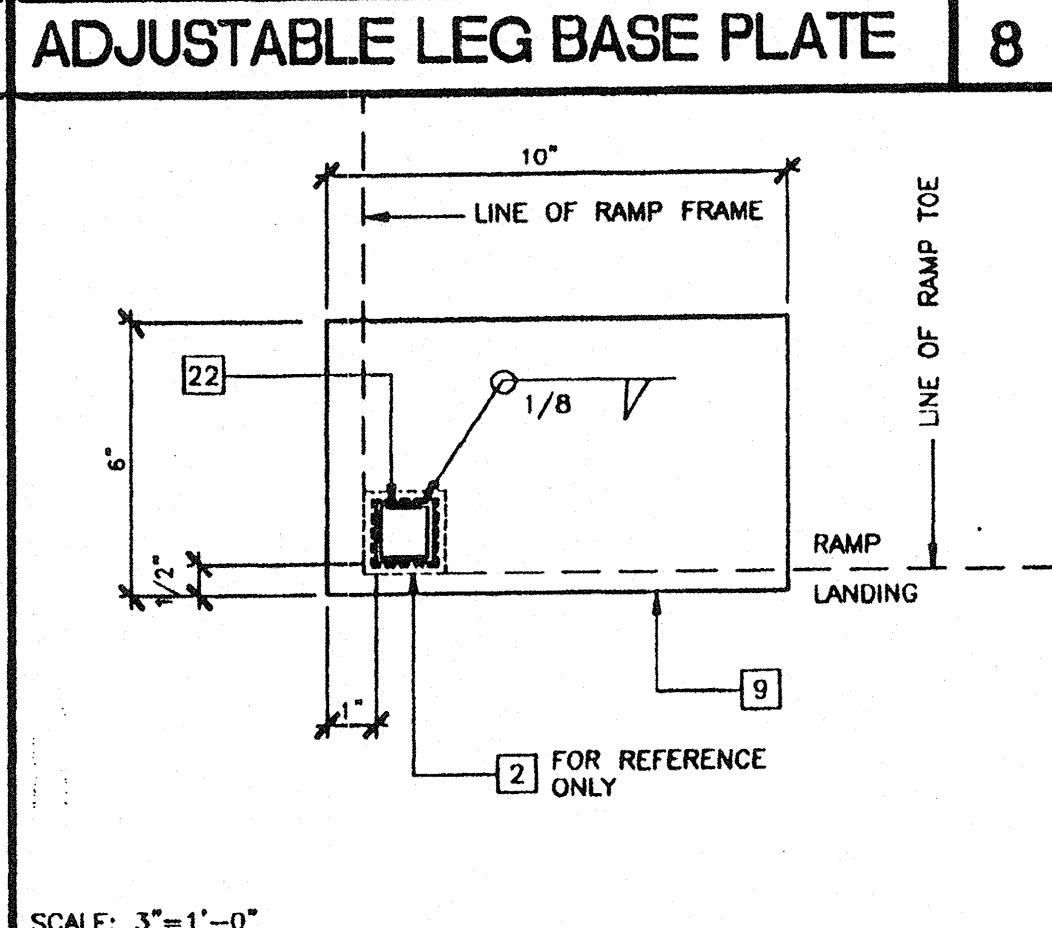
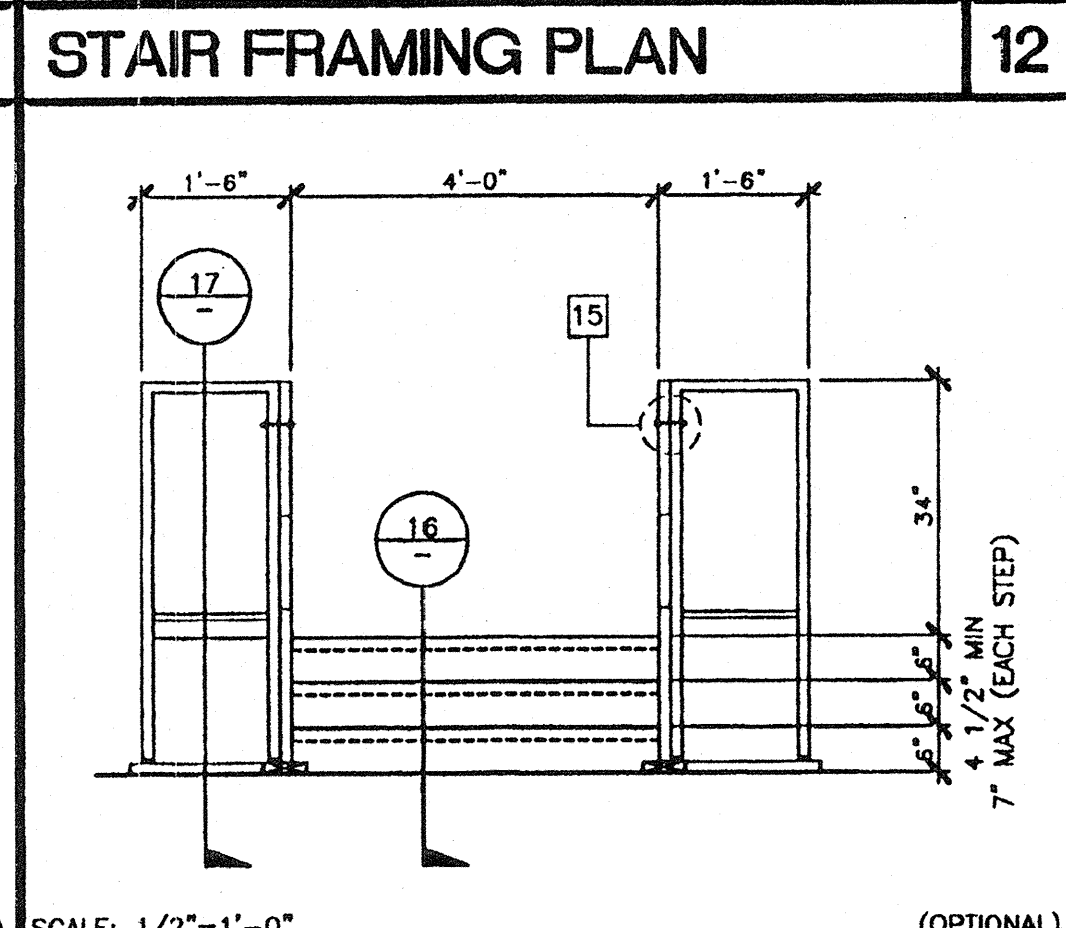
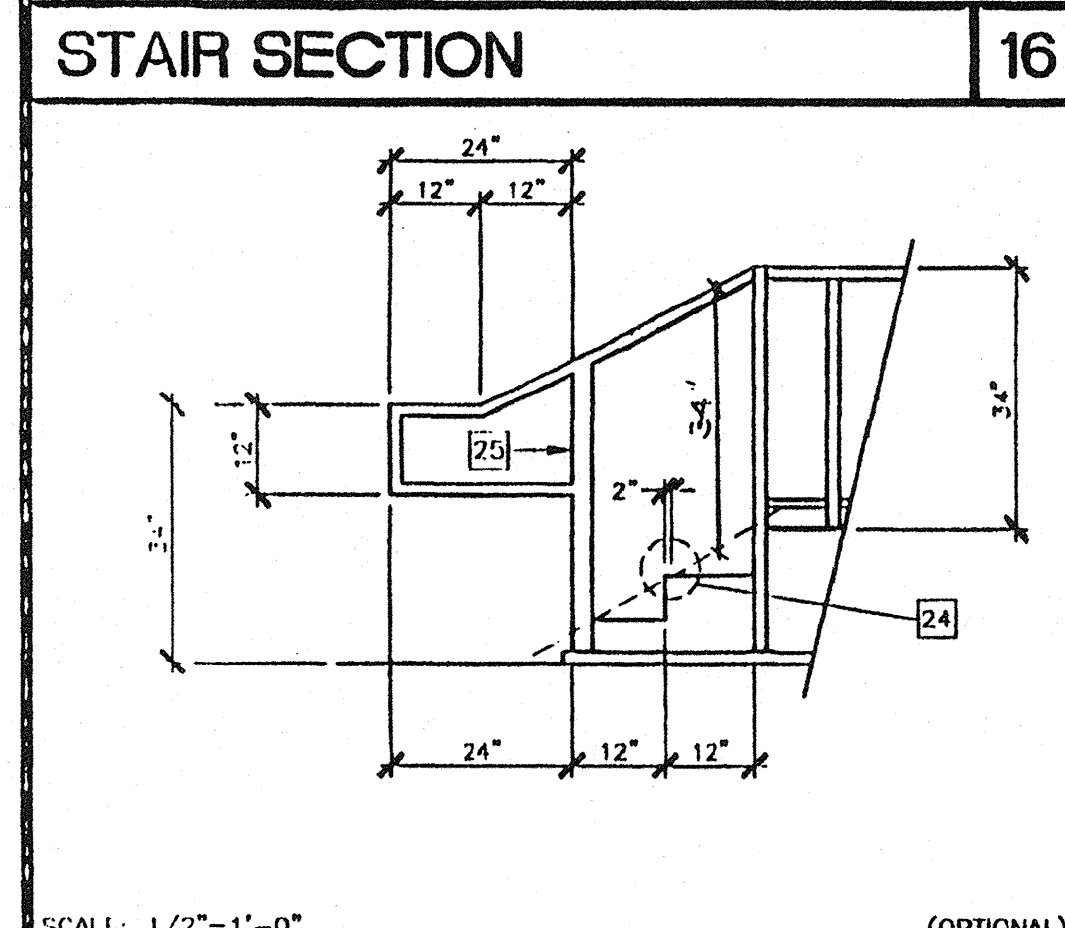
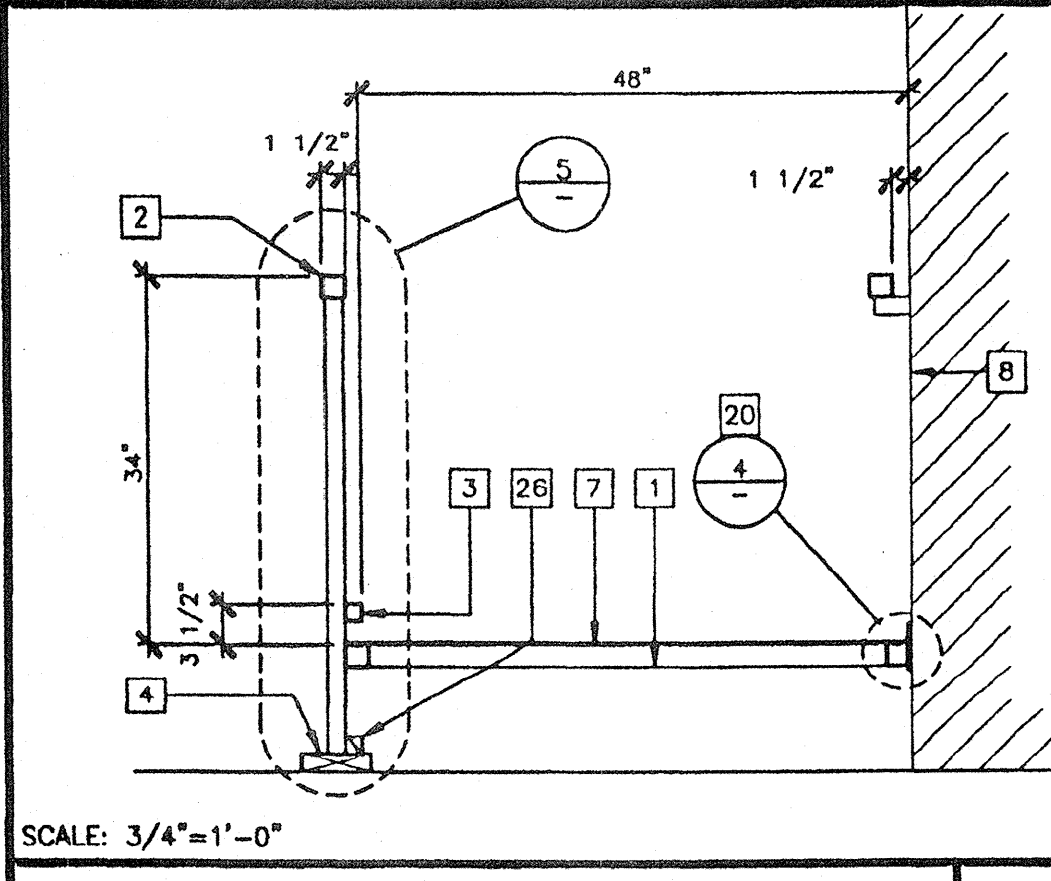
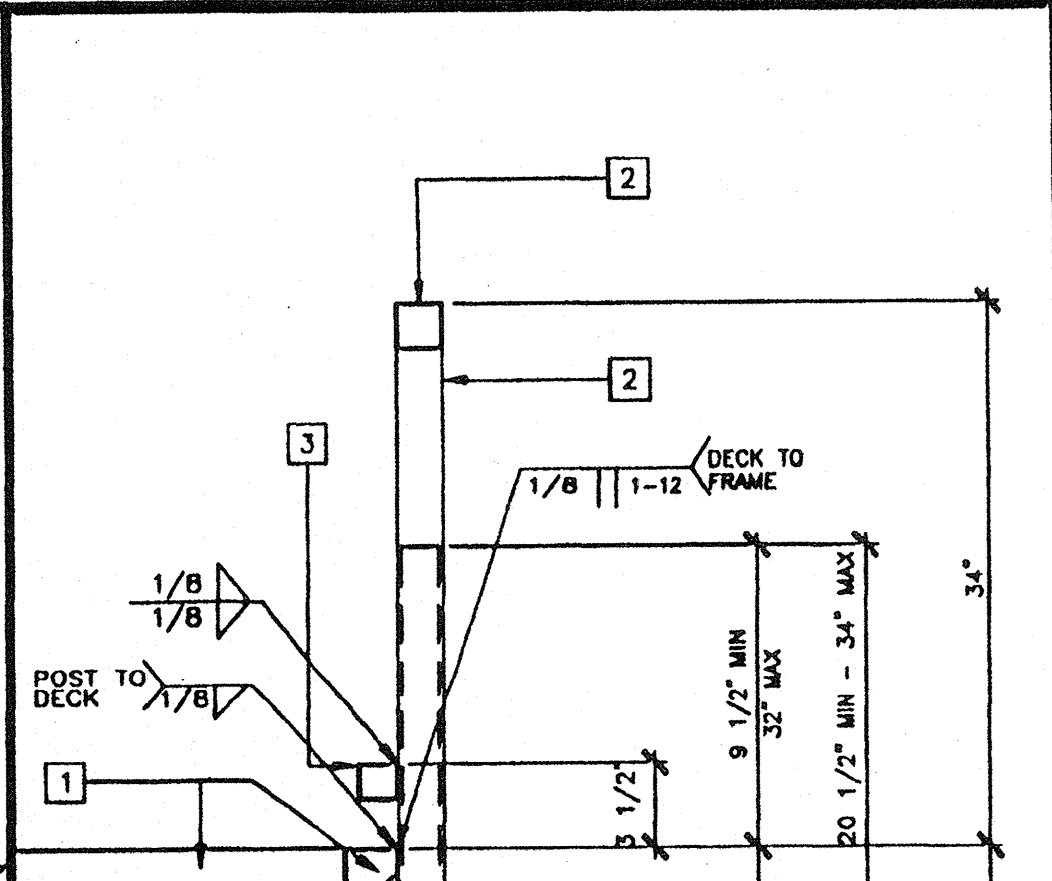
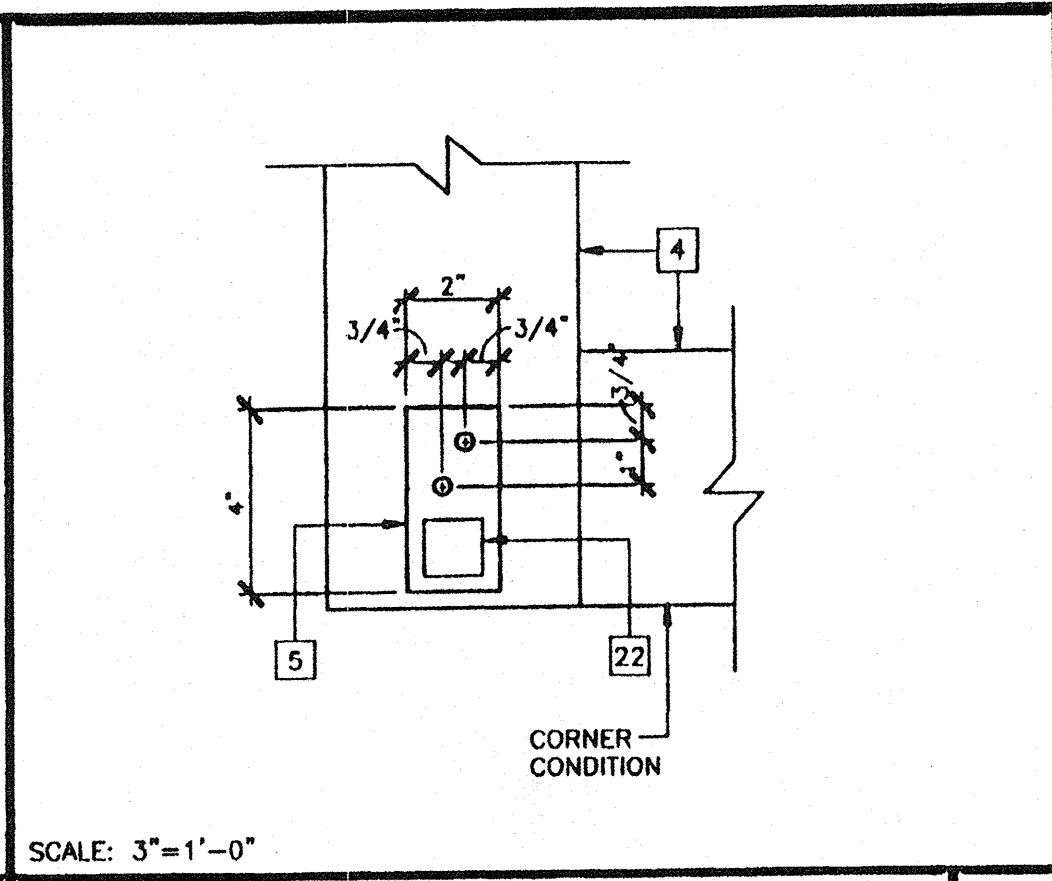
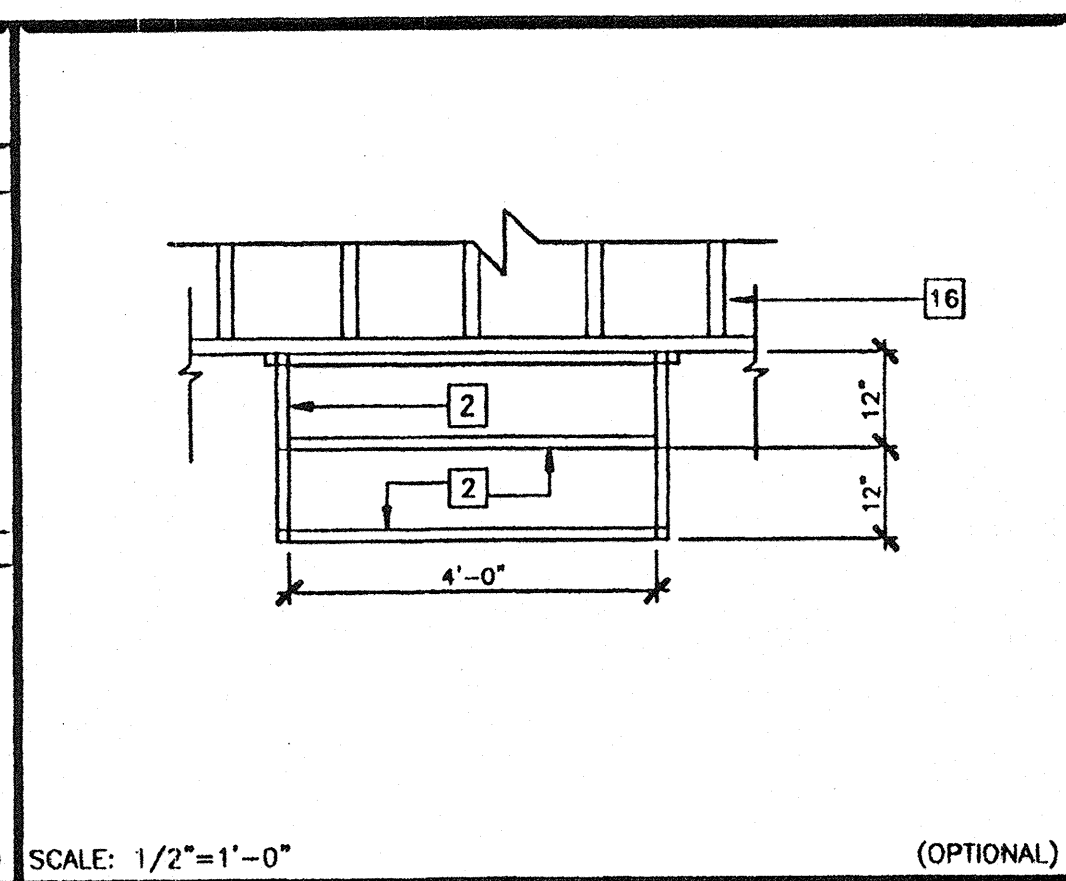
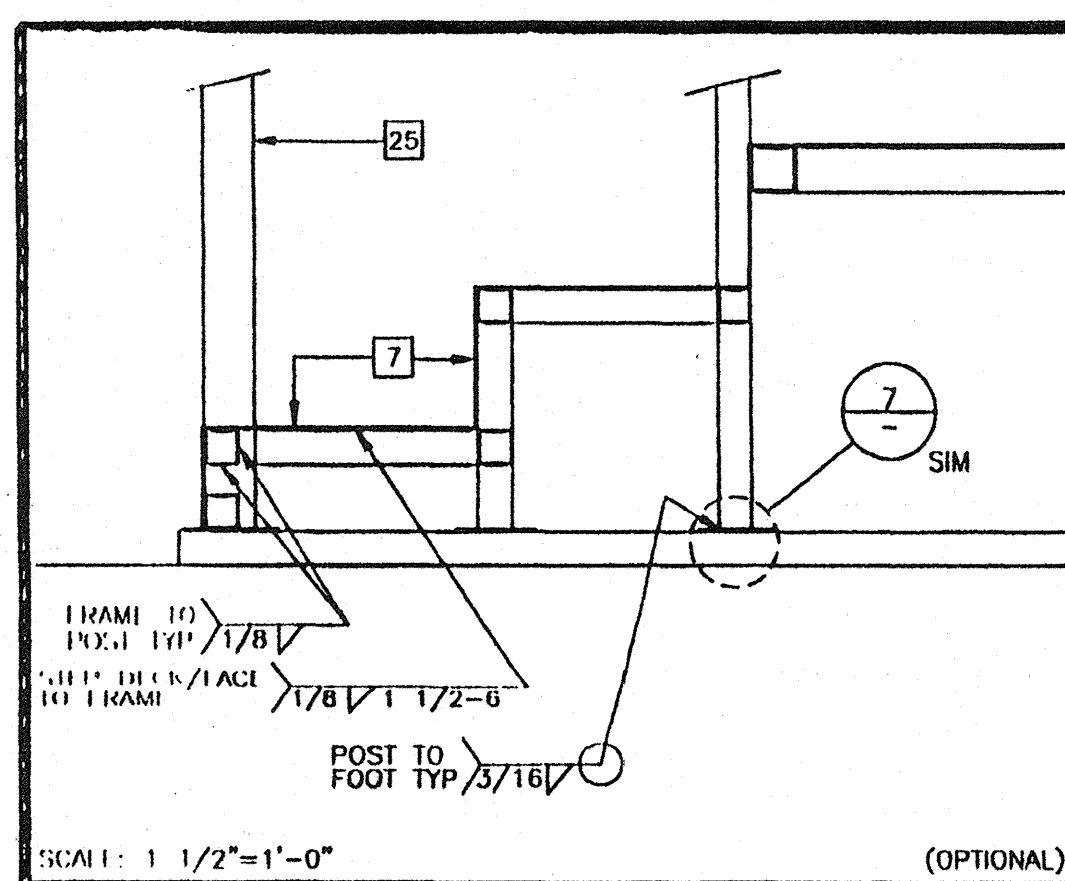

- ### KEY NOTES
- TS 2"x2"x14 GA
  - TS 1 1/2"x1 1/2"x14 GA (Fy = 39 KSI). ROUNDED OR RIVELED AT CORNERS.
  - TS 1"x1"x16 GA WHEELCHAIR GUIDE
  - 2"x6" PRESSURE TREATED SILL PLATE
  - 2"x4"x12 GA BASE PLATE WITH 2-1/4"x1" LAGS
  - SKIRTING: PLYWOOD TO MATCH BUILDING SIDING. BLOCK ALL EDGES. ATTACH WITH 8d AT 6" OC EDGES AND 12" OC FIELD. AT EDGE CONNECTION TO TS, USE #14x2" NIK SCREWS AT 6" OC
  - 12GA METAL DECK: NON-SLIP SURFACE. DESIGN COEFFICIENT OF FRICTION GREATER THAN 0.2. MAINTAINABLE FOR 1 YR. PROVIDE ROUNDED OR BEVELLED EDGES ON STAIR NOSING.
  - EXISTING BUILDING.
  - 6"x10"x12 GA BASE PLATE AT RAMP TOE.
  - LOWER LANDING BY DISTRICT
  - RAMP BY MODTECH
  - FLUSH TRANSITION
  - PAVE BY DISTRICT
  - 3"x1"x3"-0"x10 GA BENT PLATE
  - FASTEN POSTS WITH 3/8" DIA THRU BOLT, TYPICAL
  - RAMP LANDING, TYPICAL
  - 26 GA FLASHING
  - 3/8" DIAx2" LONG MB WITH NUT & WASHER
  - CAULKING
  - 6"x10GA CONTINUOUS PLATE WITH #14x2" TEK SCREWS AT 9" OC INTO WOOD OR FOUNDATION BLOCKS OR #14x2" TEK SCREWS INTO METAL AT 9" OC
  - PROVIDE DIVERSION FOR WATER FROM DOWNSHOUT FOR THIS CONDITION. BY DISTRICT
  - TS 1 1/4"x1 1/4"x14 GA (Fy = 39 KSI)
  - 4" MINIMUM BUILDING SEPARATION
  - 2" SLIP RESISTANT WARNING STRIPES MAX 1" FROM EVERY STAIR NOSING. USE CONTRASTING COLOR.
  - TS 2 1/2"x1 1/2"x8 GA ASTM A500 GRADE A
  - 2"x2" NAILER WITH 16d AT 12" OC

NO.	REVISIONS
1	
2	
3	
4	
5	
6	
7	
8	
9	
10	
11	
12	
13	
14	
15	
16	
17	
18	
19	
20	
21	
22	

Electrical Engineer's Seal  
Mechanical Engineer's Seal  
Architect's Seal

IDENTIFICATION STAMP  
DIV. OF THE STATE ARCHITECT  
OFFICE OF REGULATION SERVICES  
PC-04  
101419  
AC: [Signature]  
DATE: OCT 25 1999

**MODTECH INC.**  
2830 BARRETT AVENUE  
PERRIS, CALIF. 92572  
PH (909) 943-4014  
FAX (909) 940-0427

PROJECT NUMBER: © MODTECH, INC. 1999

IDENTIFICATION STAMP  
DIV. OF THE STATE ARCHITECT  
OFFICE OF REGULATION SERVICES  
APPROVED: [Signature]  
DATE: 7/24/14  
IDENTIFICATION STAMP  
DIV. OF THE STATE ARCHITECT  
OFFICE OF REGULATION SERVICES  
04:01984  
AC: [Signature]  
DATE: MAR 09 2000

DRAWN BY:  
DATE:  
CHECKED BY: SS  
DATE: 10/22/99  
MODTECH Index No.  
**R1.02**

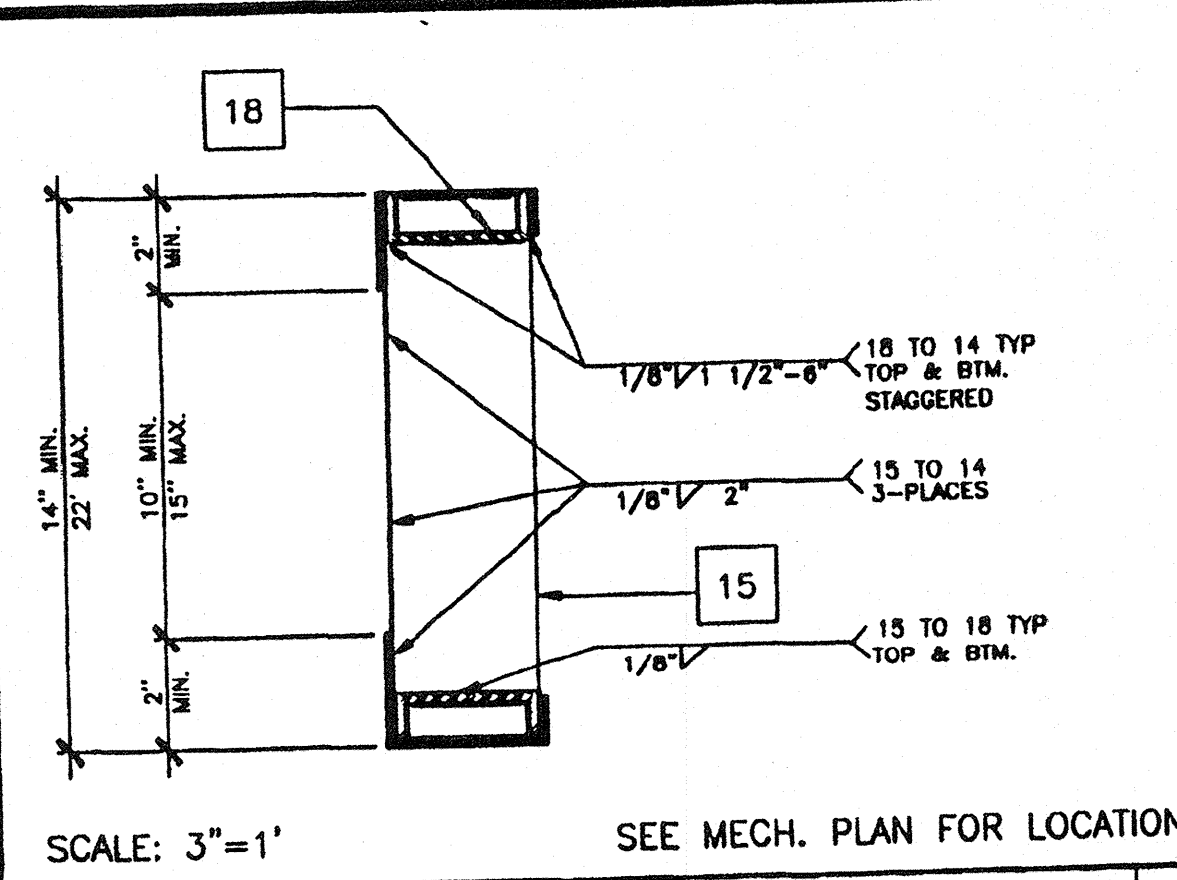

MECH. DUCT OPENING IN ROOF BM. 8

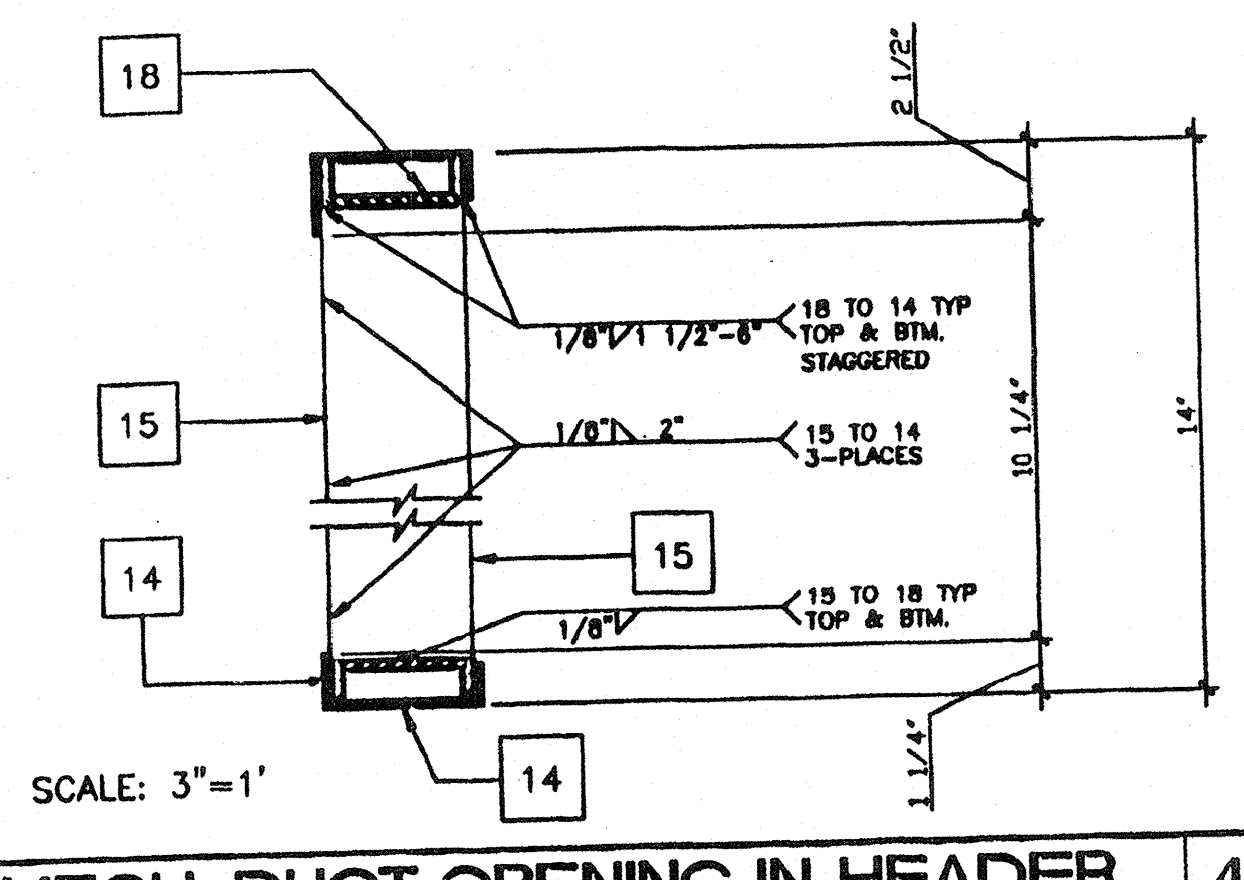

MECH. DUCT OPENING IN HEADER 4

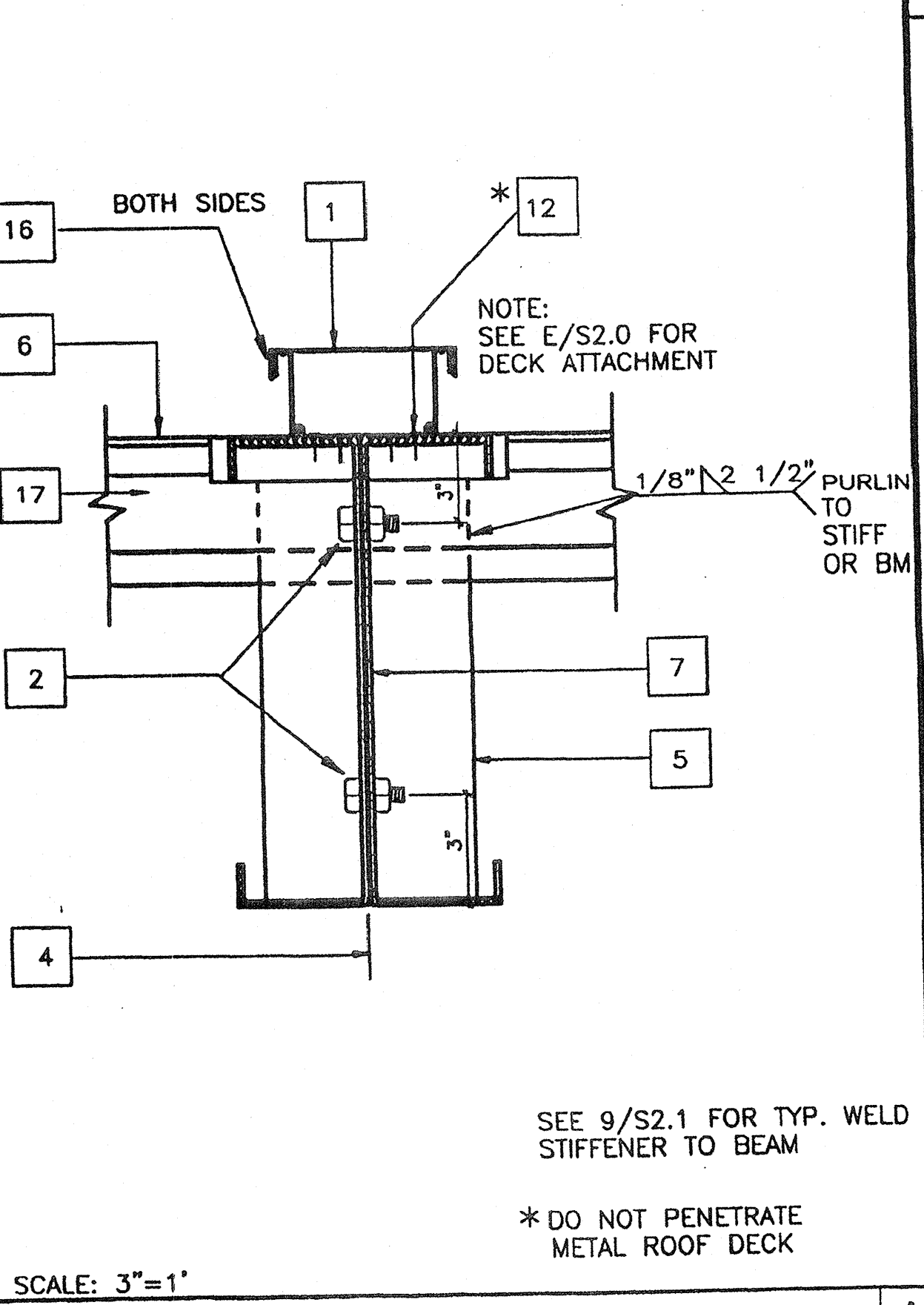

ROOFING @ MODLINE 1

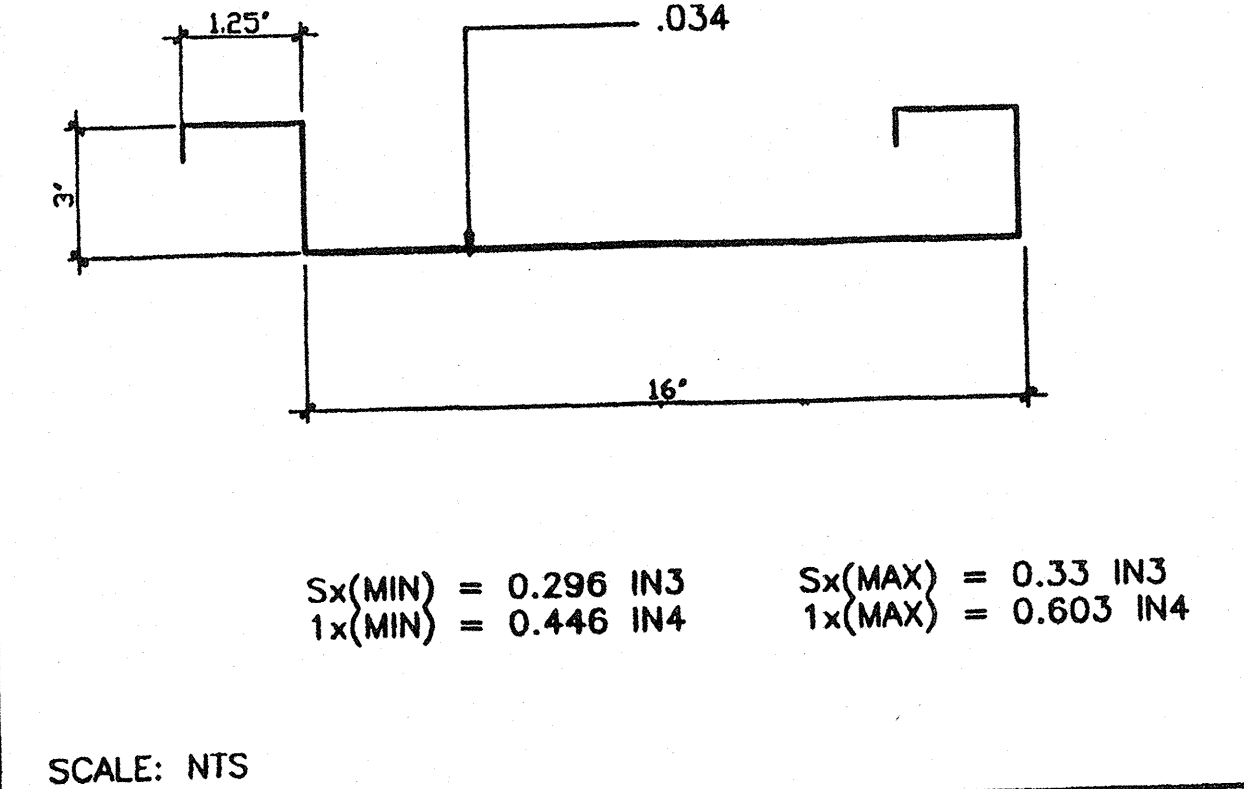

ROOF PAN (22GA.) 5

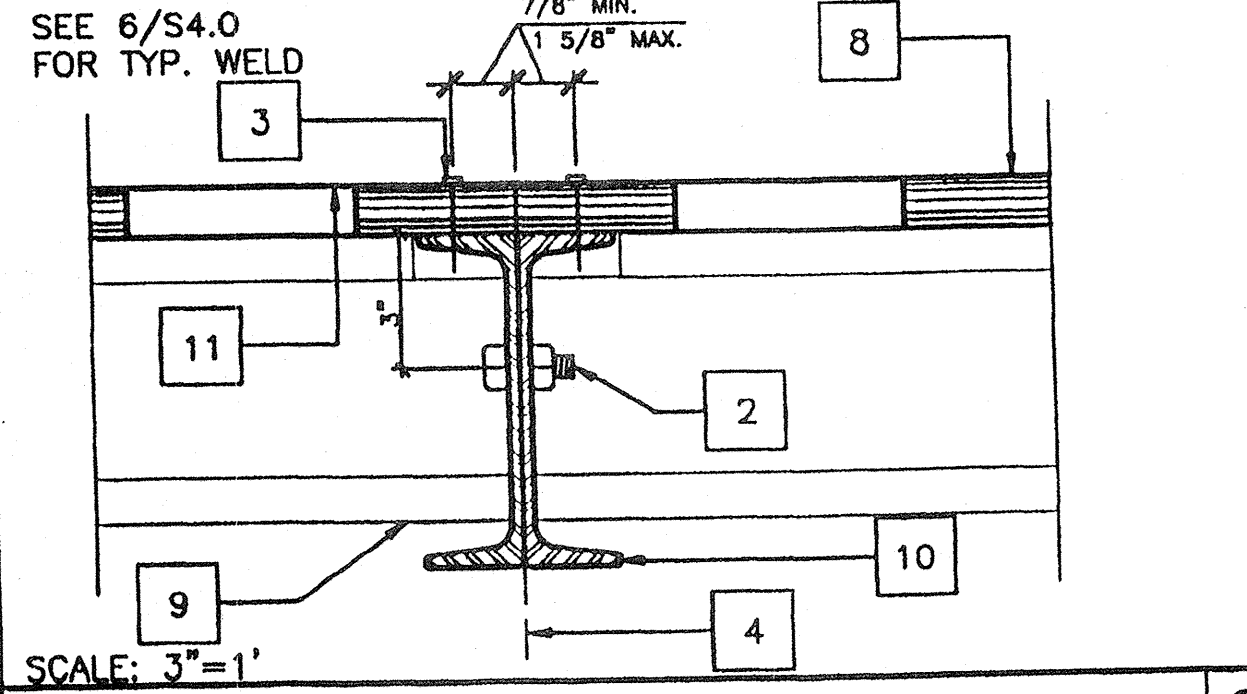

MODULE JOINT AT FLR. 12'-0" 2

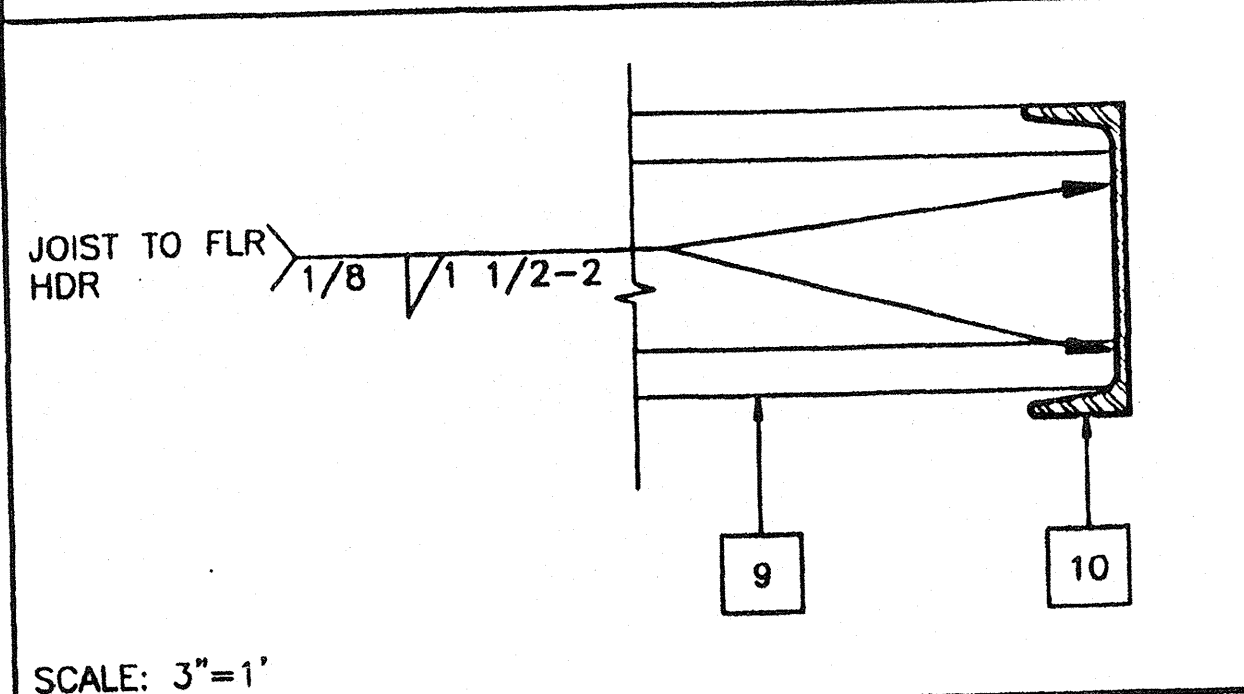

FLOOR FRAME/JOIST TO BEAM 6

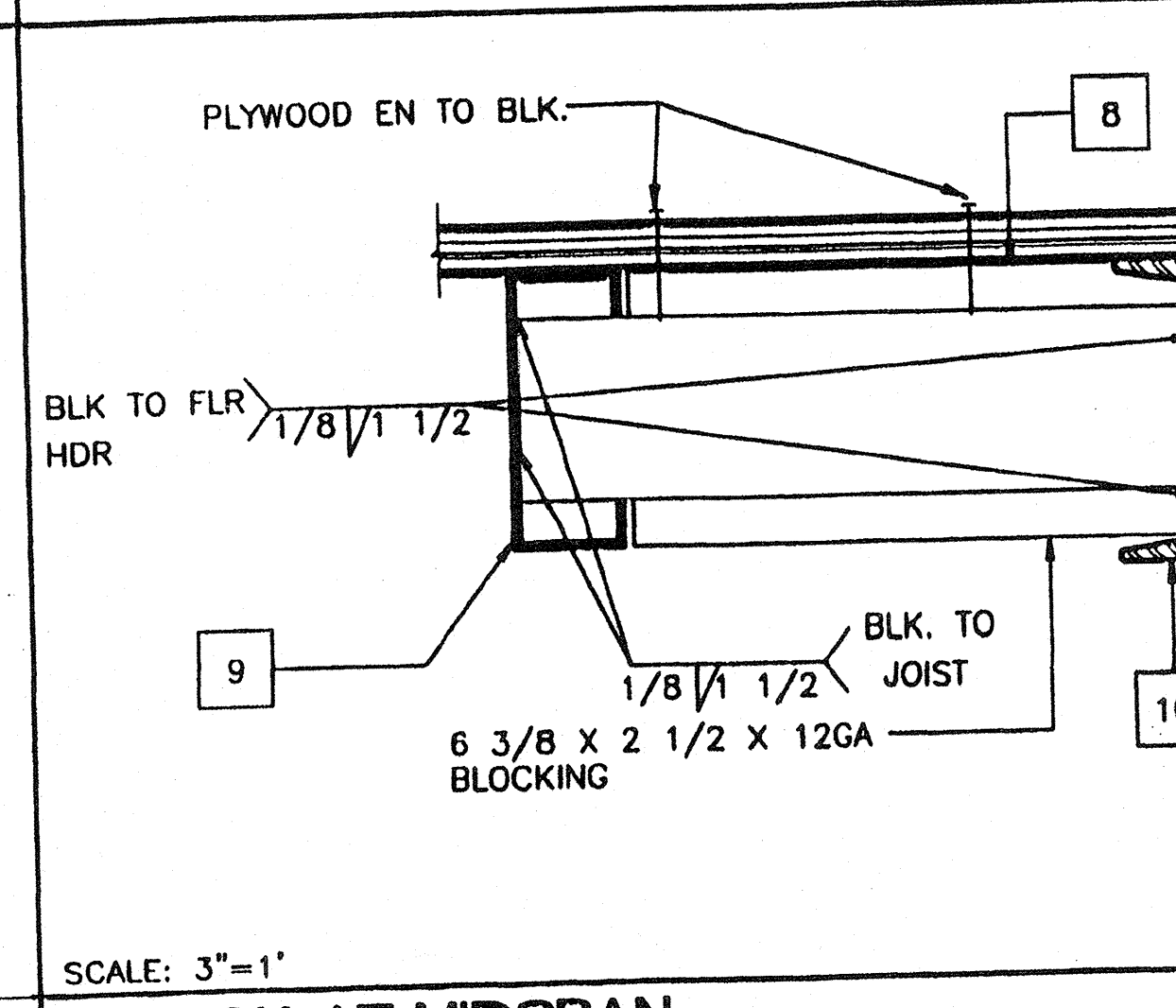

BLOCK AT MIDSPAN 10

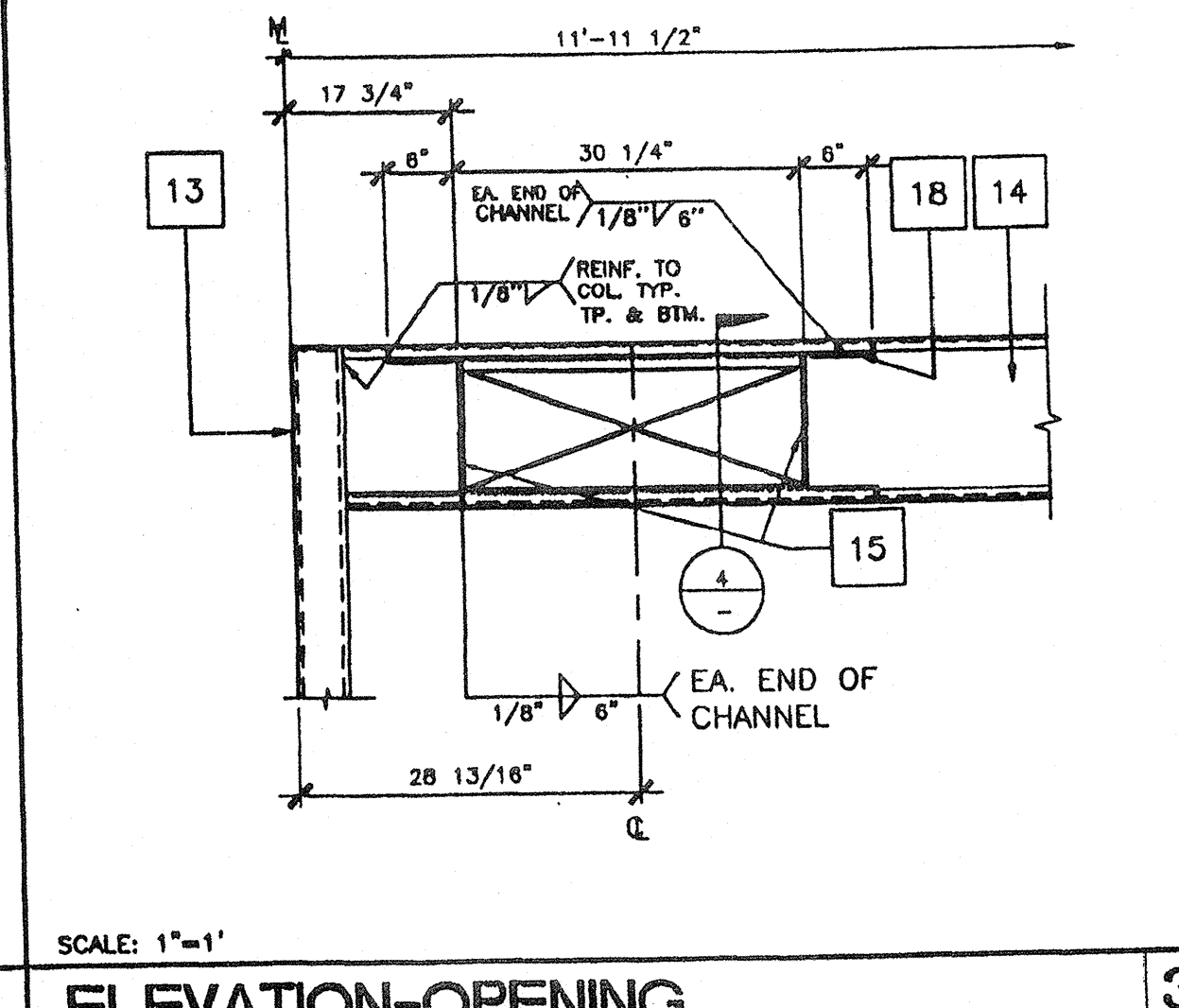

ELEVATION-OPENING 7

KEY NOTES

- 1 CAP CLOSURE AT RIDGE 26GA. GALV. W//10 TYPE FASTENERS W/NEOPRENE WASHERS TO RIB BOTH SIDES OF MODLINE. SET CAP IN SLANT. BOTH SIDES
- 2 5/8" M.B. A307 MODULE JOINT (SEE STRUCTURAL PLAN FOR LOCATION) AT 8" O.C.
- 3 E.N.
- 4 MODULE JOINT
- 5 14" THK X 3" FULL DEPTH STIFFENER PLATE AT RIDGE ONLY (SEE 9/S2.1)
- 6 STANDING ROOF SEAM (SEE A2.0)
- 7 ROOF BEAM SEE 1/S2.1 & 7/S2.1
- 8 PLYWOOD FLOOR SHEATHING
- 9 FLOOR JOIST SEE 6/S2.1
- 10 FLOOR BEAM SEE 5/S2.1
- 11 HAND HOLE AT BOLT LOCATION
- 12 #14 STSMS.
- 13 3 1/2"x3 1/2"x1/4" STEEL TUBE COLUMN. SEE 12/S2.1
- 14 ROOF HEADER SEE 3/S2.1
- 15 1/4" STIFFENER PLATE SEE 9/S2.1 FOR TYP. WELD
- 16 SEALANT
- 17 ROOF PURLIN SEE 2/S2.1
- 18 3 1/4" X 1" X 45 11/16" LG X 10GA CHANNEL TOP AND BOTTOM OF OPENING

CBC 1993  
PC

IDENTIFICATION STAMP  
DIV. OF THE STATE ARCHITECT  
OFFICE OF REGULATION SERVICES  
04 101984  
AC FLS SS  
DATE MAR 09 2000

IDENTIFICATION STAMP  
DIV. OF THE STATE ARCHITECT  
APPROX 118000  
AC FLS SS JB  
DATE 7/24/14

REVISIONS	Electrical Engineer's Seal	Mechanical Engineer's Seal	Structural Engineer's Seal	Architect's Seal

IDENTIFICATION STAMP  
DIV. OF THE STATE ARCHITECT  
OFFICE OF REGULATION SERVICES  
PC-04  
101419  
AC FLS SS  
DATE OCT 25 1000

MODTECH INC.  
2830 BARRETT AVENUE  
PERRIS, CALIF. 92572  
PH (909) 943-4014  
FAX (909) 940-0427

PROJECT NUMBER: \_\_\_\_\_  
© MODTECH, INC. 1999

DRAWN BY: \_\_\_\_\_  
CHECKED BY: SS  
DATE: 10/22/99

MODTECH Index No. \_\_\_\_\_

**STRUCTURAL DETAILS**

**S1.2**

PROJECT NO. PC-04-101419