

1 ELEV. OF COUNTER IN CLERK  
A. 7' x 1/2" x 1'-0" (ARCH)

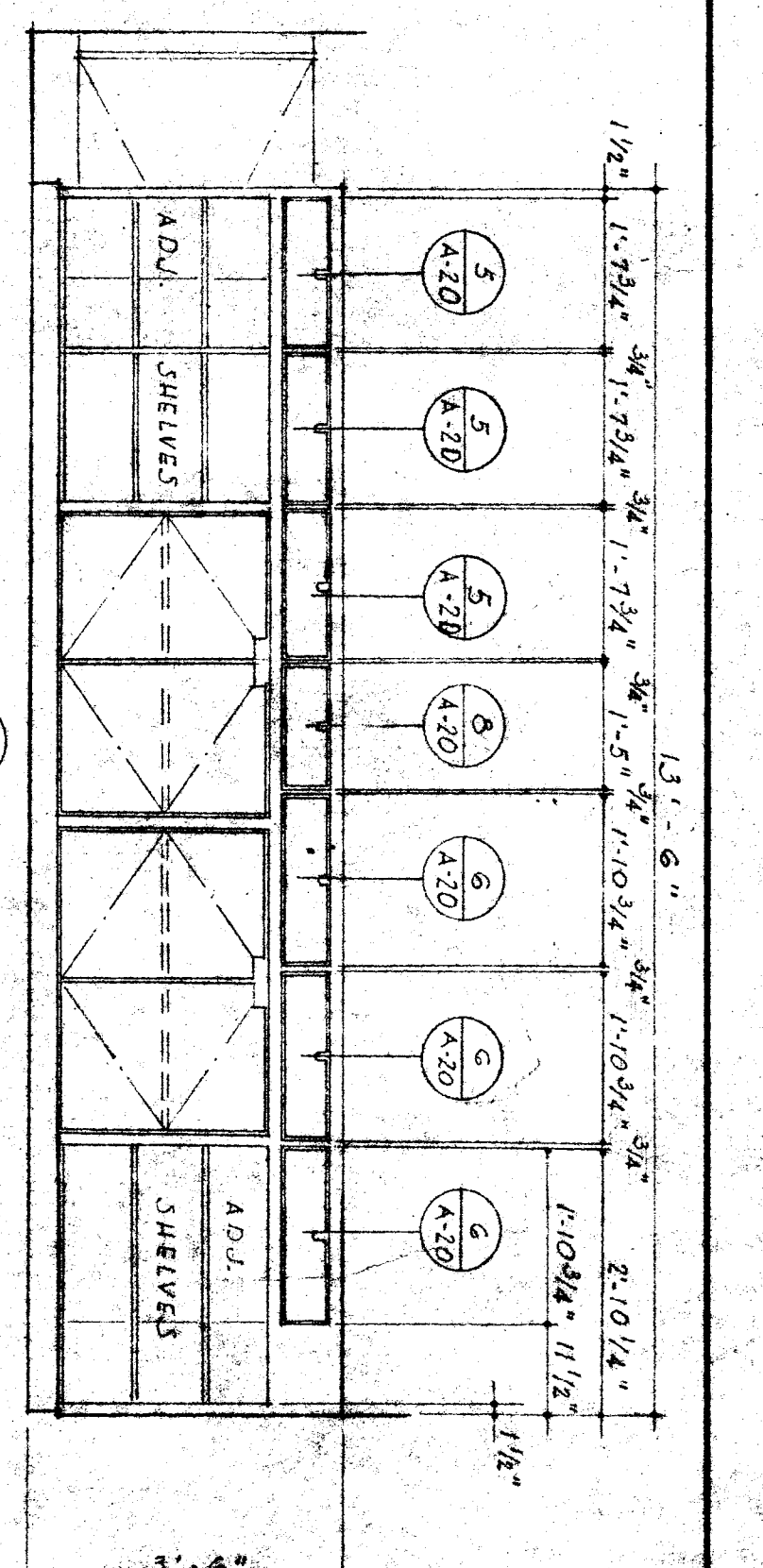

2 ELEV. OF COUNTER IN CLERK A. 7' x 1/2" x 1'-0"

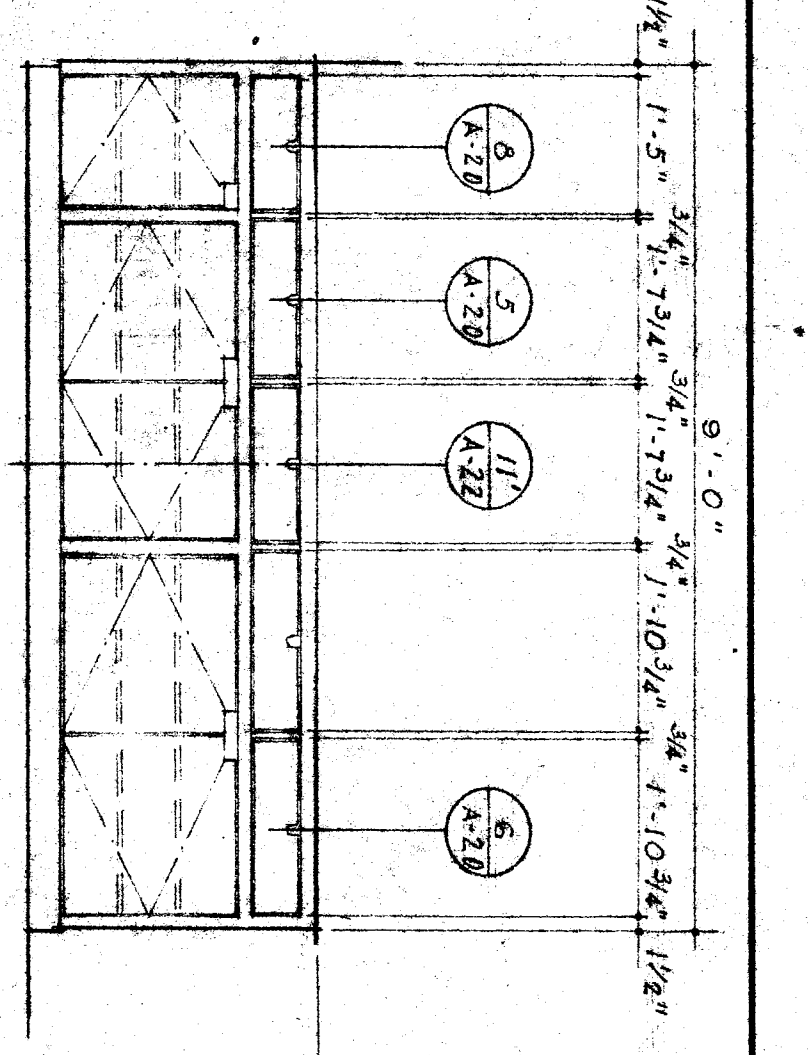

3 ELEV. OF COUNTER IN CLERK  
A. 9' x 1/2" x 1'-0" (COUNCILS FIB)

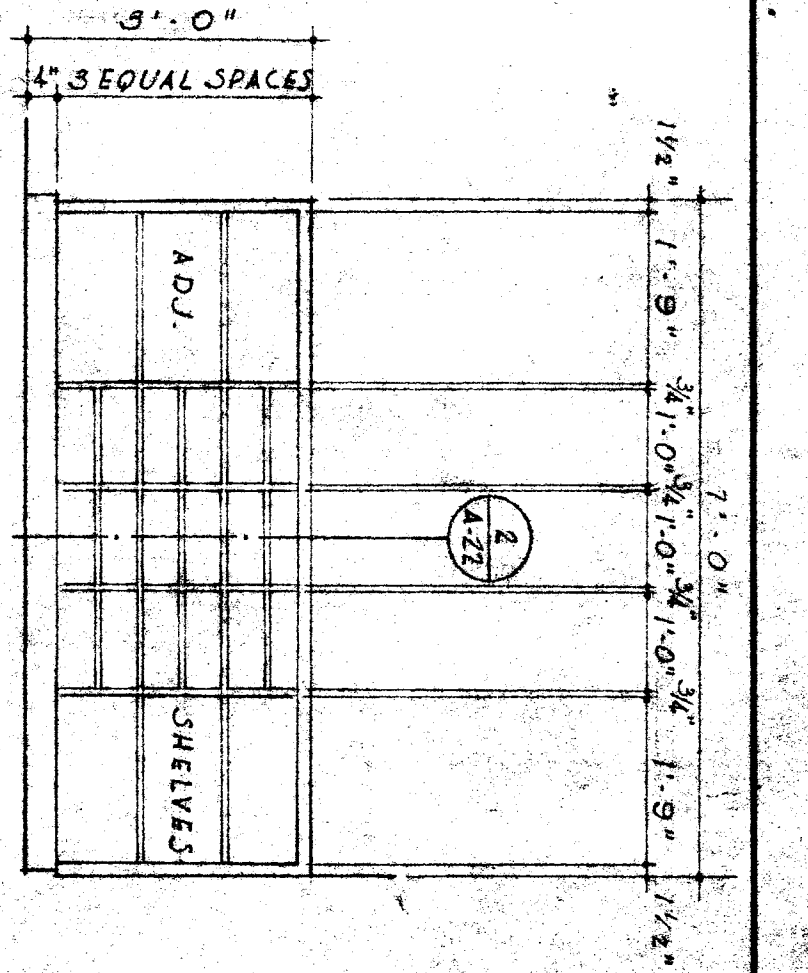

4 ELEV. OF COUNTER IN PRINCIPAL  
A. 12' x 1/2" x 1'-0"

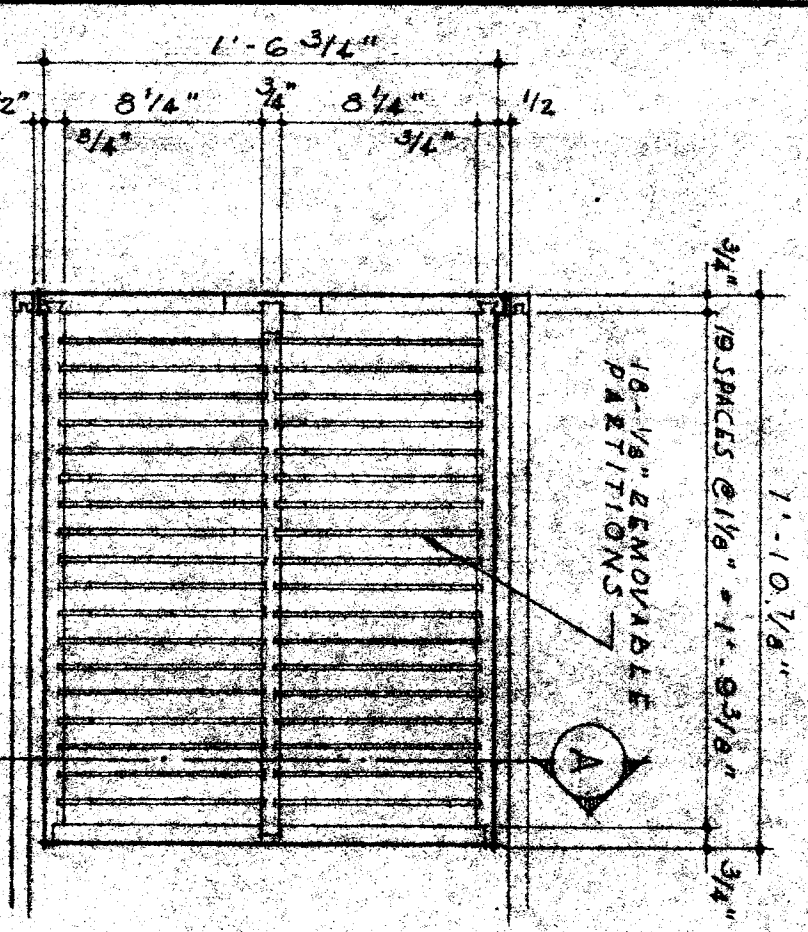

5 PLAN OF CARD FILE DRAWER - 1/2 x 1'-0"

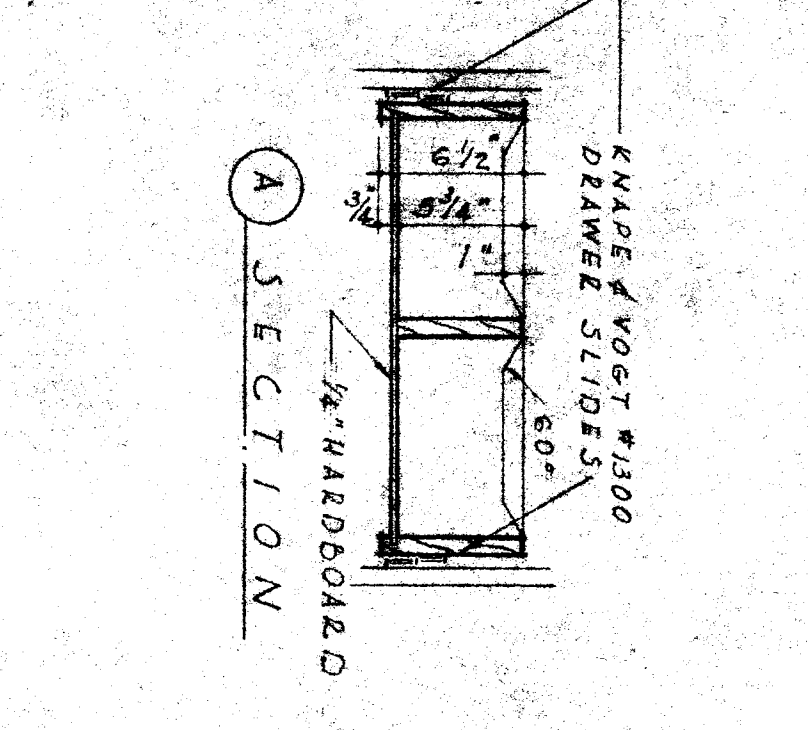

A SECTION

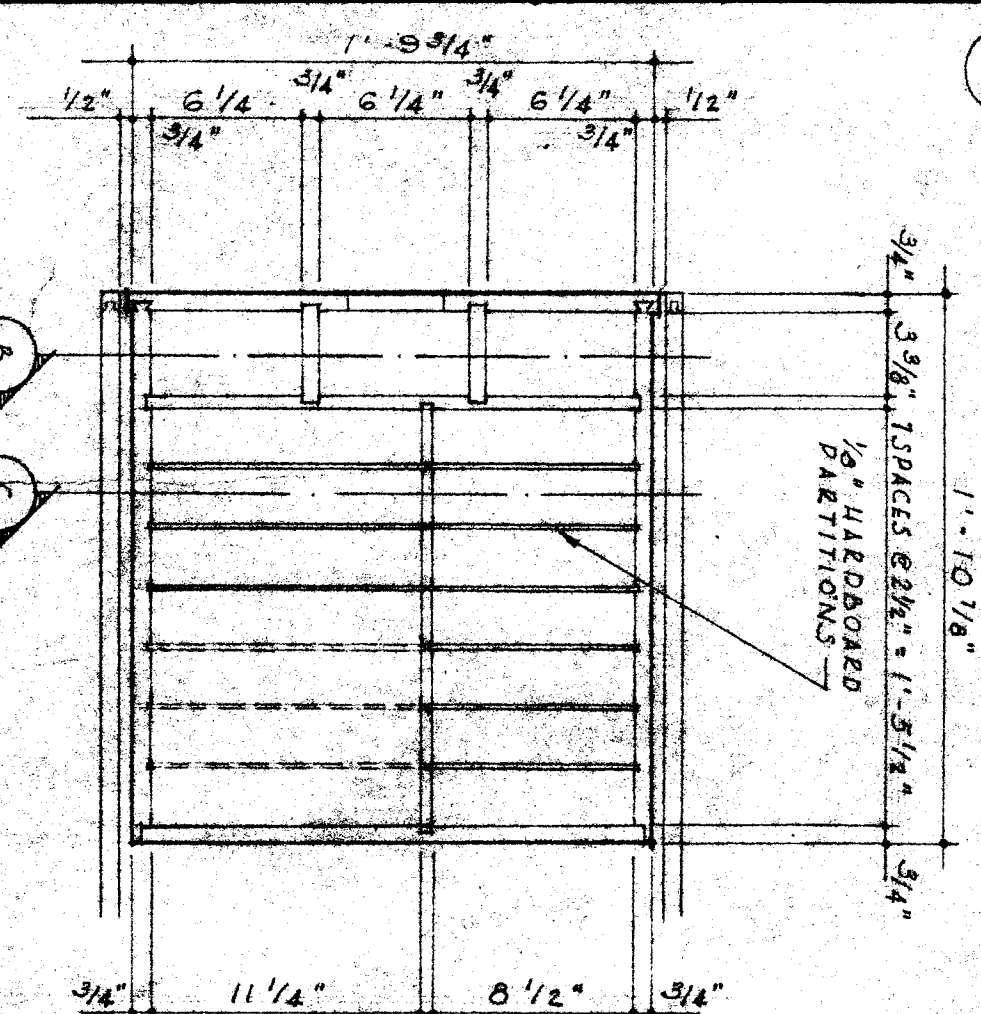

6 PLAN OF CARD FILE DRAWER - 1/2 x 1'-0"

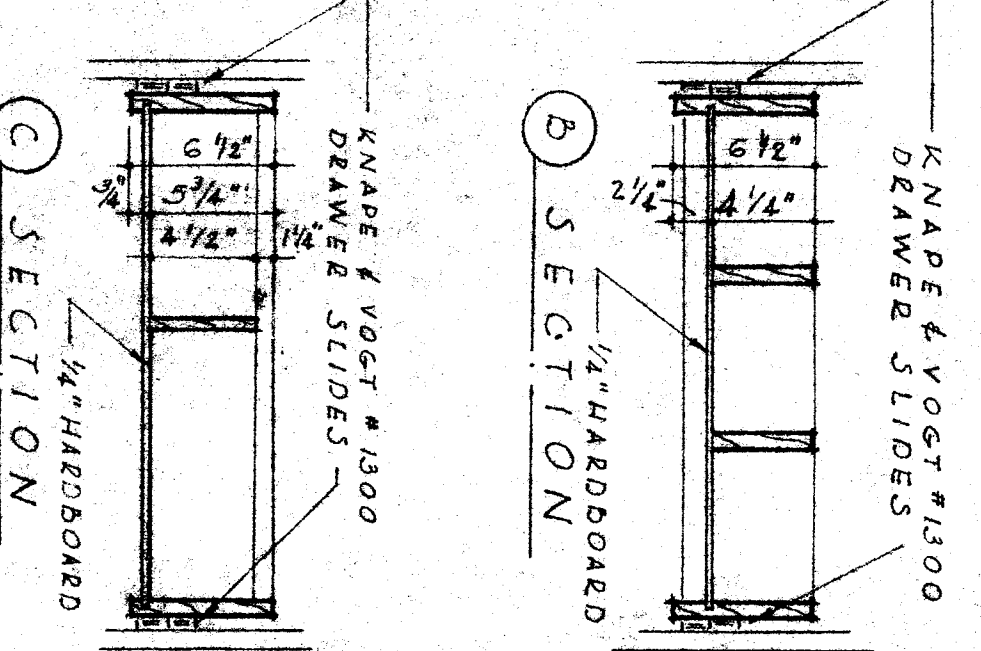

B SECTION

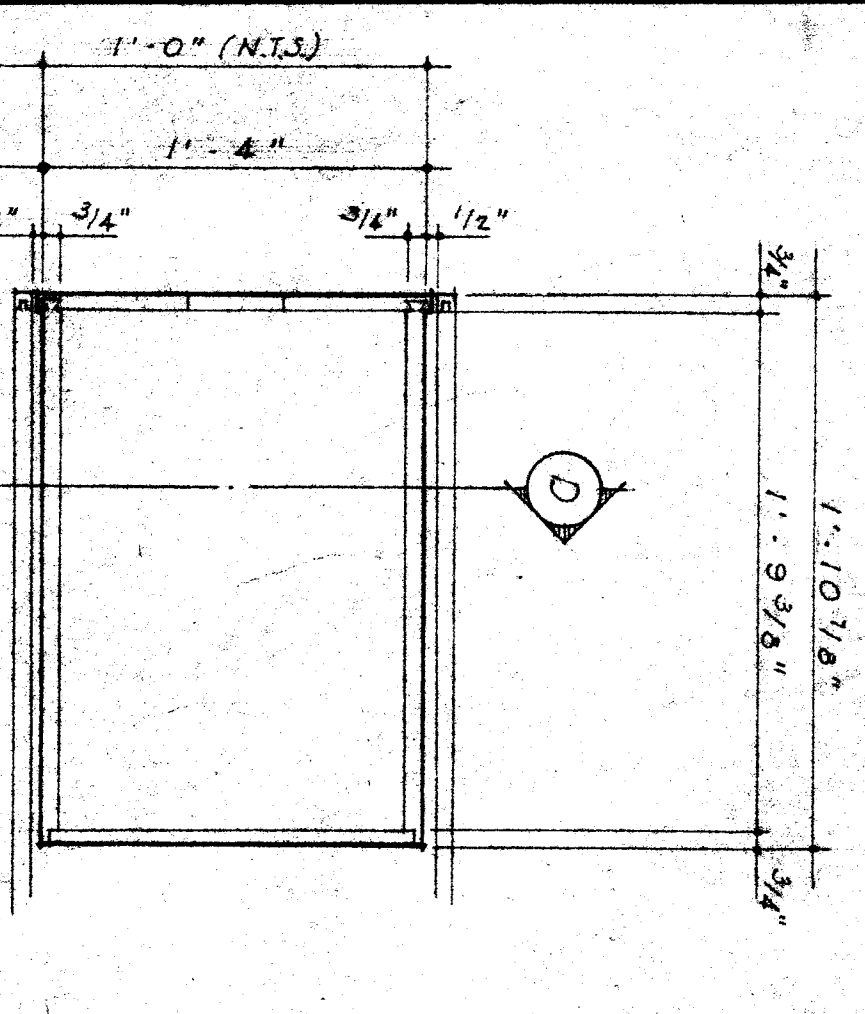

7 PLAN OF MISC. DRAWERS - 1/2 x 1'-0"

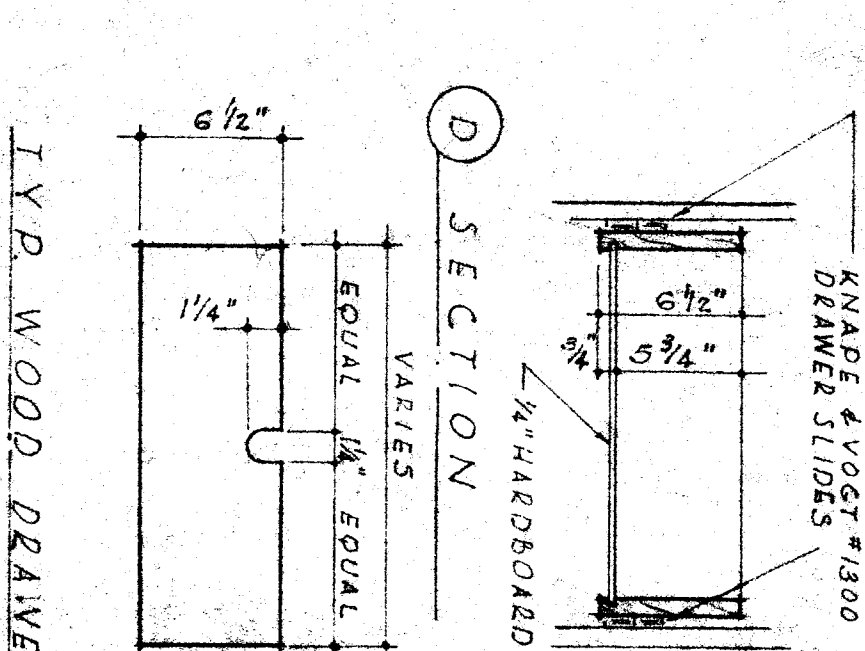

C SECTION

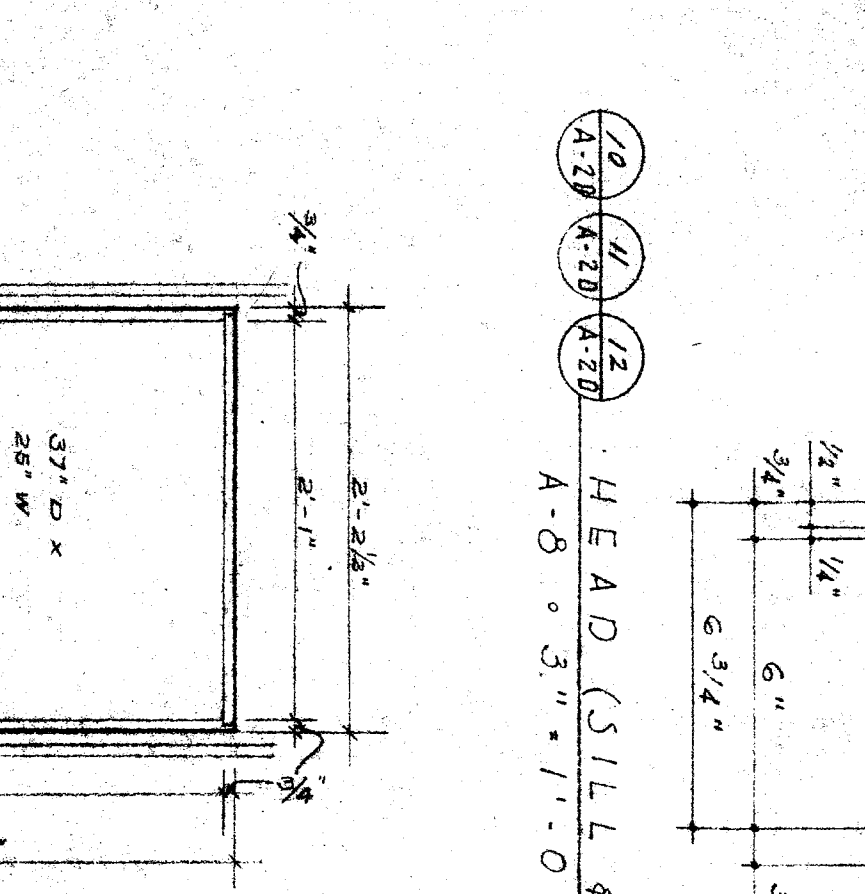

TYR WOOD DRAWER FRONT

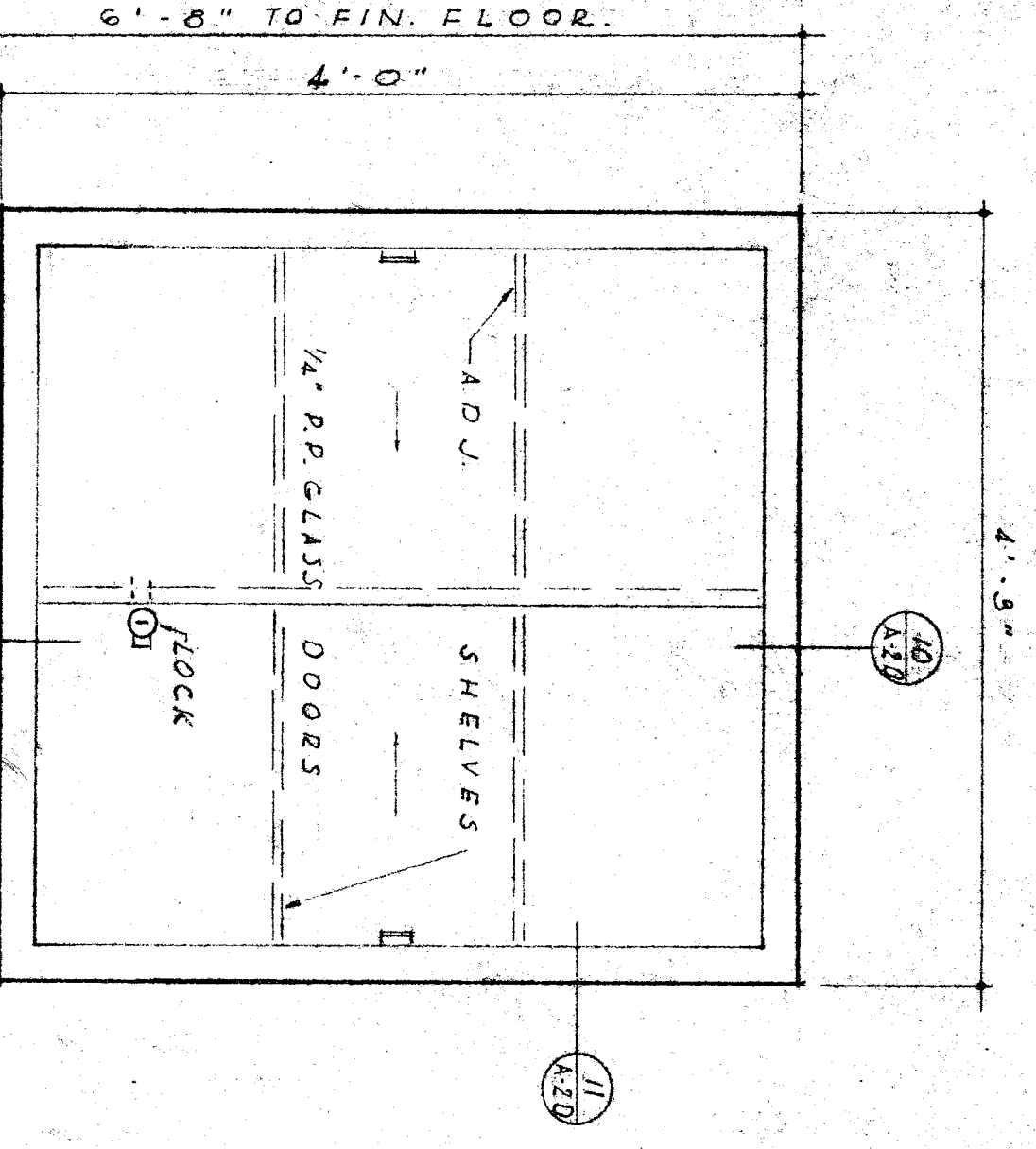

8 ELEV. OF SHOWCASE IN PUBLIC  
A. 8' x 1" x 1'-0"

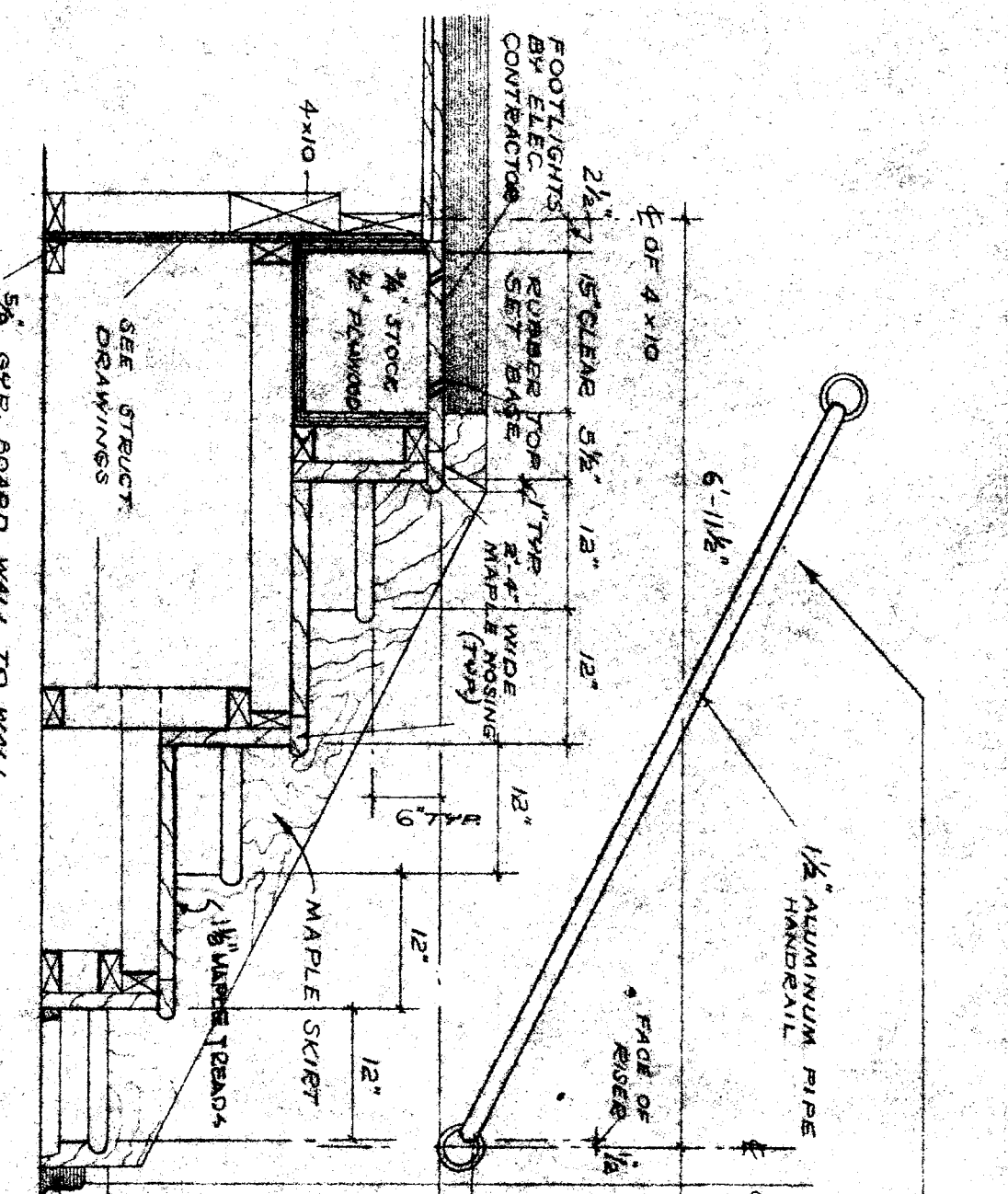

9 PLATFORM SECTION - 3/4 x 1'-0"

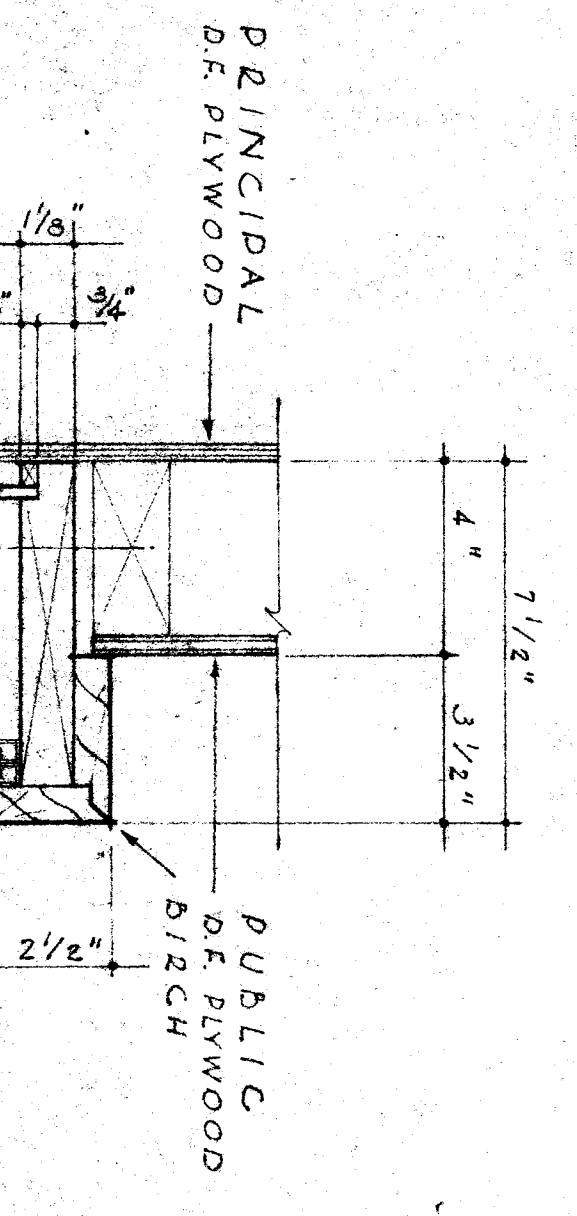

10 HEAD (SILL & JAMB) (SILL)

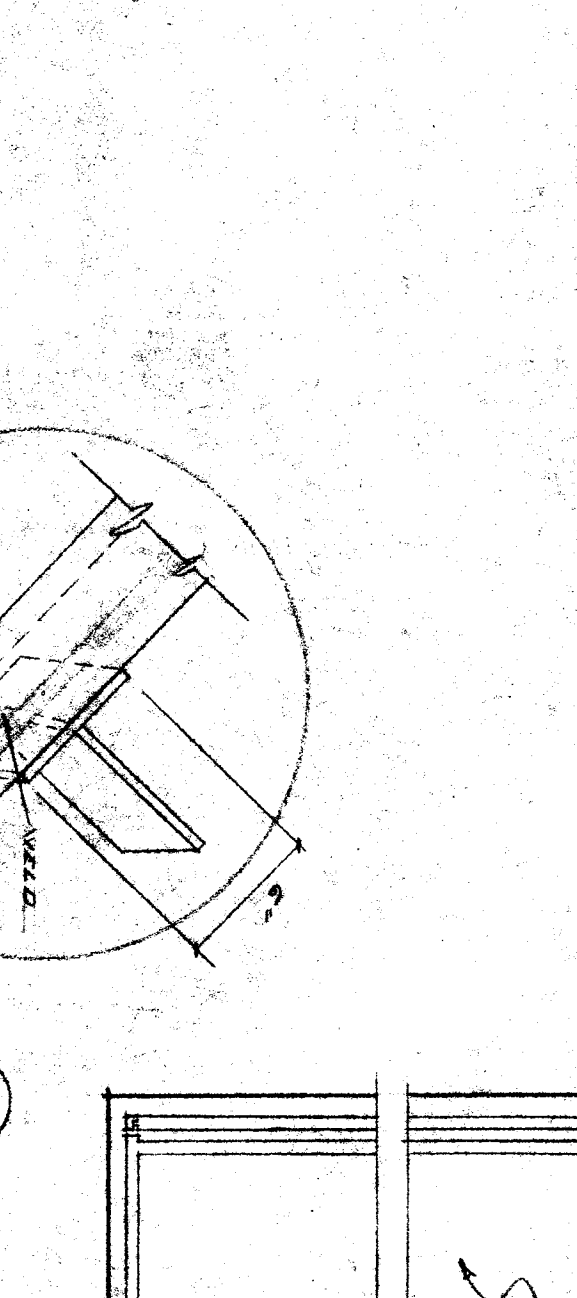

11 PLAN OF BENCH - 5'-1 1/2" x 1'-0"

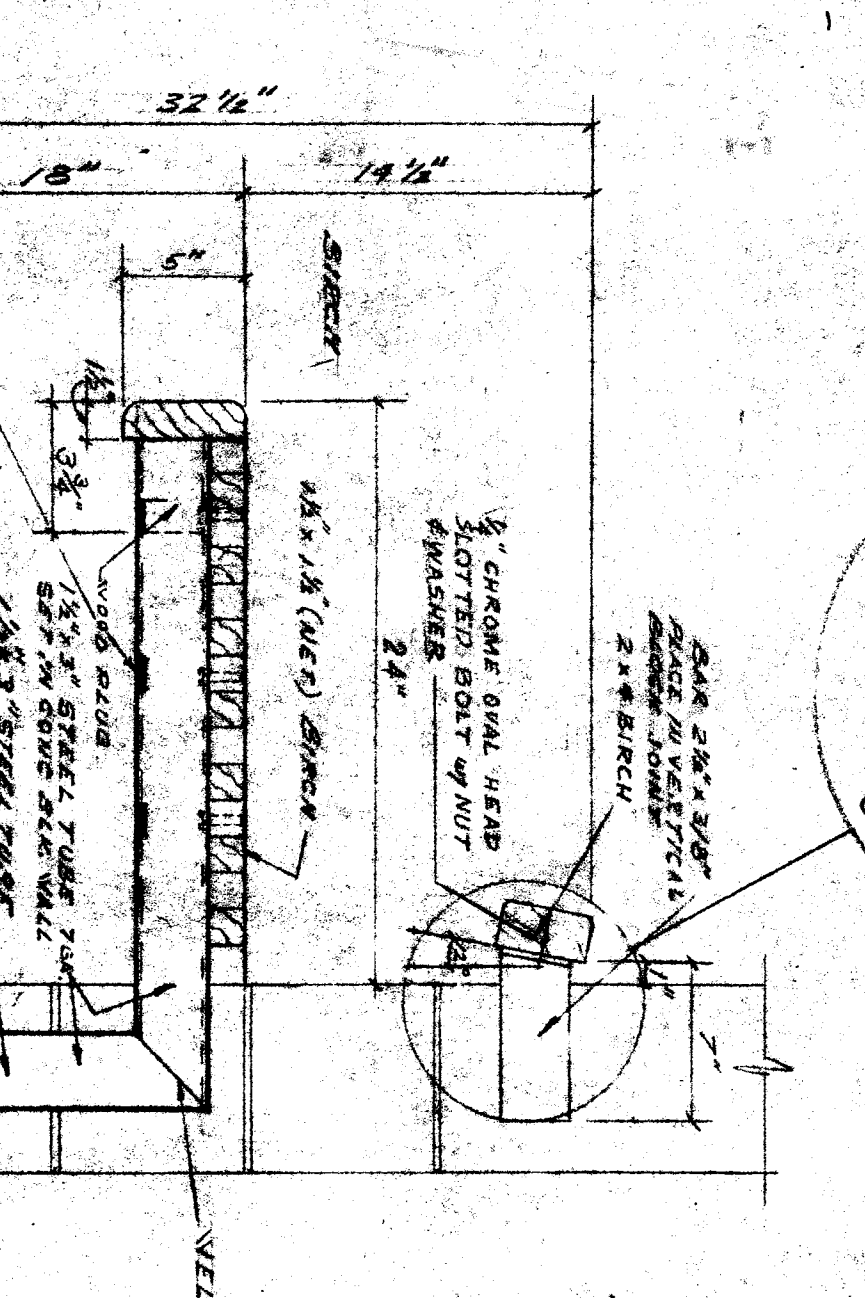

A SECTION

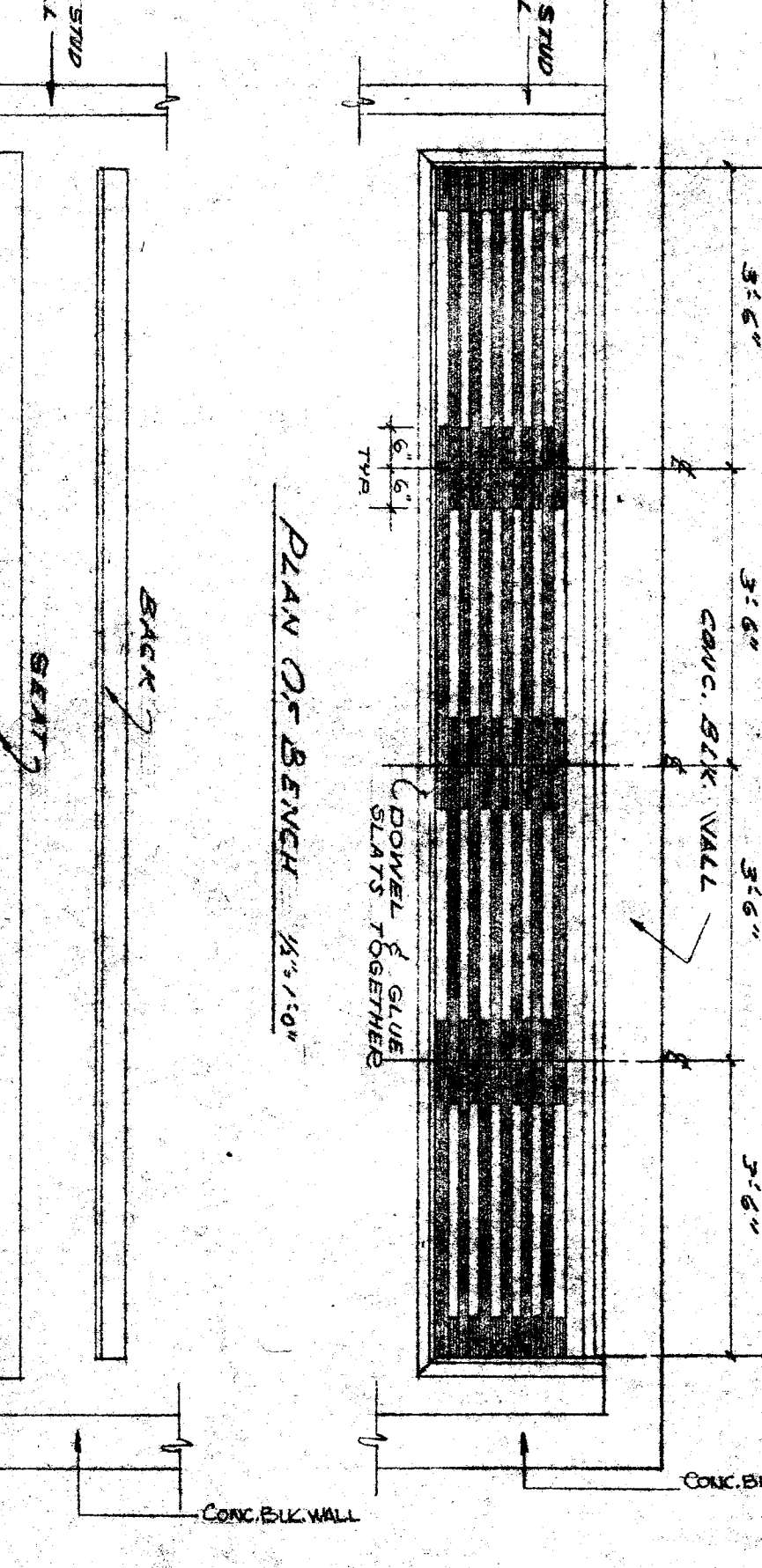

FRONT VIEW OF BENCH 1'-0" x 1'-0"

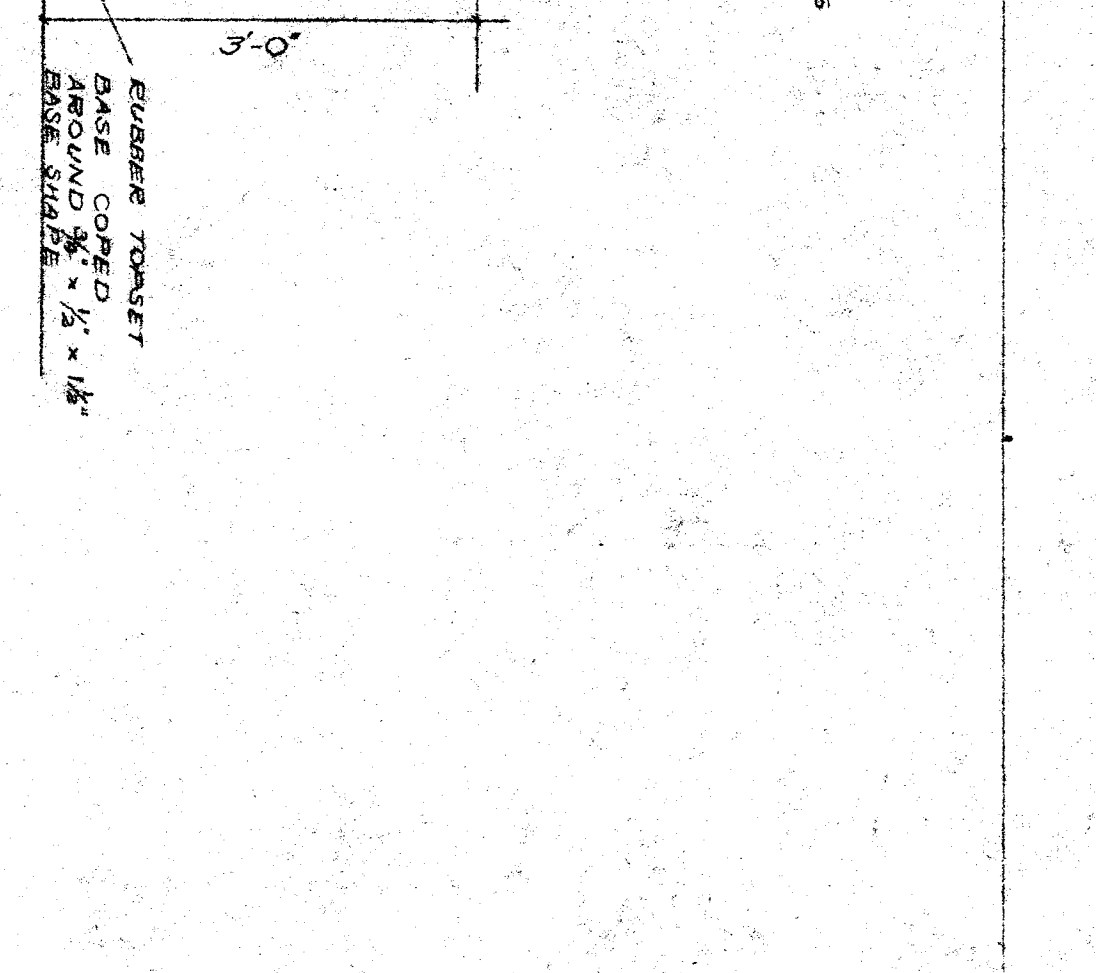

12 STAIR SECTION - 3/4 x 1'-0"

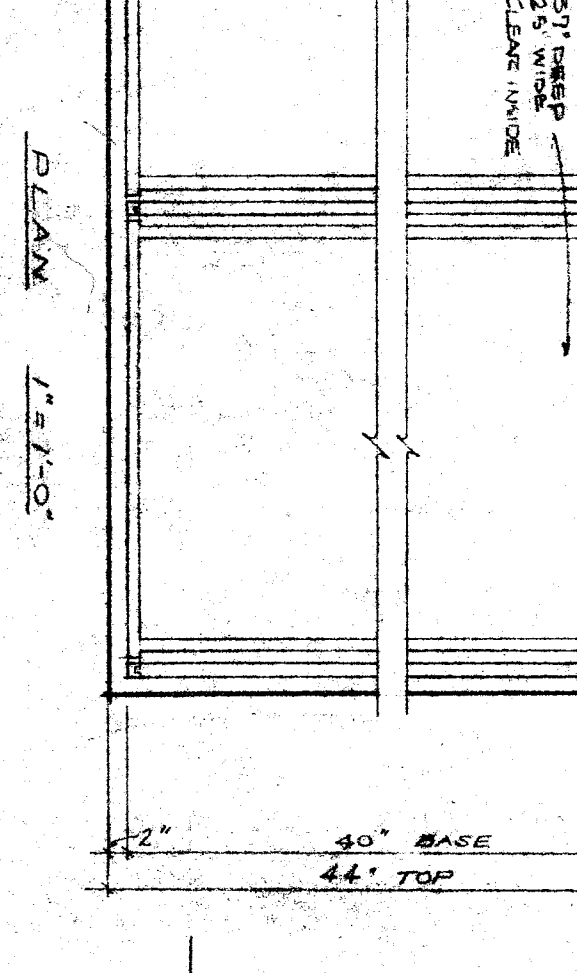

13 PLAN OF WORK TABLE

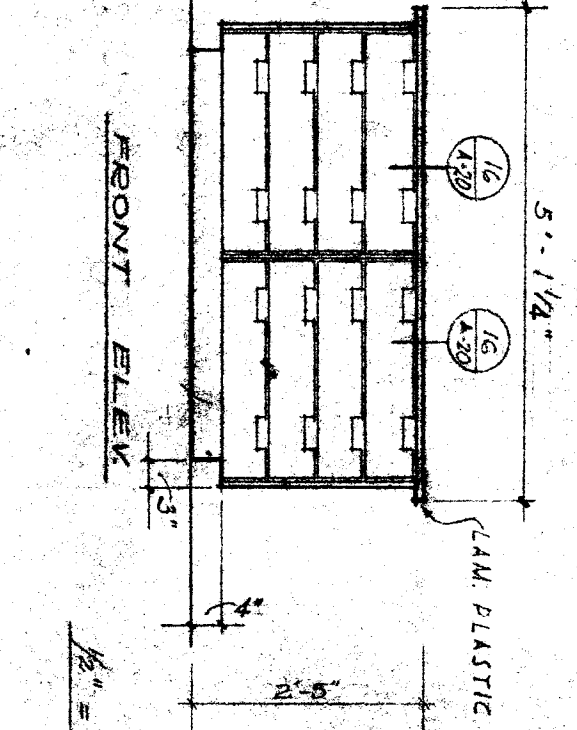

14 ELEV. OF COUNTER IN ALL

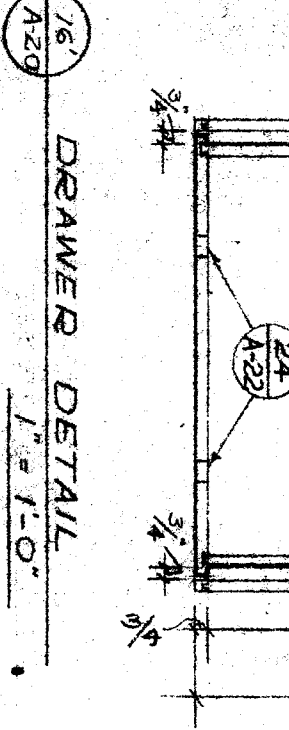

15 DRAWER DETAIL  
1'-0" x 1'-0"

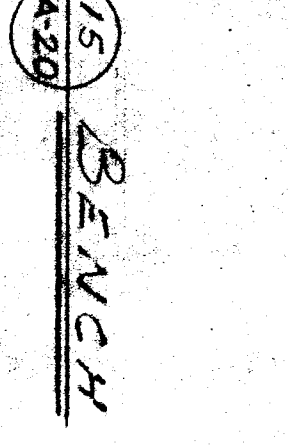

16 BENCH



17 SECTION 1/5 SCHOOL

OFFICE OF SUPERINTENDENT OF SCHOOLS  
APPROVED

STATE OF CALIFORNIA  
DEPARTMENT OF PUBLIC WORKS  
DIVISION OF ARCHITECTURE

20571  
DEC 19 1930

BAKERSFIELD CITY SCHOOL DISTRICT  
BAKERSFIELD, CALIFORNIA  
BOARD OF EDUCATION

APPROVED  
DATE

BAKERSFIELD CITY SCHOOL DISTRICT  
BOARD OF EDUCATION  
ERNEST L. MCCOY A. I. A.

SECTION 1/5 SCHOOL  
BAKERSFIELD, CALIFORNIA

ERNEST L. MCCOY A. I. A.  
ARCHITECT  
BAKERSFIELD, CALIFORNIA

SECTION 1/5 SCHOOL  
BAKERSFIELD, CALIFORNIA

