



# **BID PROJECT MANUAL**

## **Stiern Middle School Spray Polyurethane Foam Roofing**

### **PROJECT#**

**Project 26247.00-20-DM**

**BAKERSFIELD CITY SCHOOL DISTRICT**

**June 2026**

**TABLE OF CONTENTS****Procurement and Contracting Requirements**

<u>Division 0</u>	<u>Section</u>	<u>Title</u>
	00 01 01	Project Title Page
	00 01 10	Table of Contents
	00 01 15	List of Drawings and Tables
	00 01 20	List of Schedules

**Solicitation**

<u>Division 0</u>	<u>Section</u>	<u>Title</u>
	00 11 16	Notice to Bidders

**Instructions for Procurement**

<u>Division 0</u>	<u>Section</u>	<u>Title</u>
	00 21 13	Instructions to Bidders
	Work Scope	BP-01 Roofing

**Procurement Forms and Supplements**

<u>Division 0</u>	<u>Section</u>	<u>Title</u>
	00 41 13	Bid Form and Proposal
	00 43 13	Bid Bond
	00 43 36	Designated Subcontractors List
	<del>00 45 01</del>	<del>Site Visit Certification</del>
	00 45 19	Non-Collusion Declaration
	00 45 19.01	Iran Contracting Act Certification
	00 45 19.03	Russia Sanctions Certification
	00 45 26	Workers' Compensation Certification
	00 45 46.01	Prevailing Wage and Related Labor Requirements Certification
	00 45 46.02	Disabled Veteran Business Enterprise Participation Certification
	00 45 46.03	Drug-Free Workplace Certification
	00 45 46.04	Tobacco-Free Environment Certification
	00 45 46.05	Drug and Alcohol-Free Schools Certification
	00 45 46.06	Lead-Based Materials Certification
	00 45 46.08	Criminal Background Investigation/Fingerprinting Certification
		[RESERVED]
	00 45 46.10	Roofing Project Certification
	00 45 49	DIR Registration Verification

**Contracting Forms and Supplements**

<u>Division 0</u>	<u>Section</u>	<u>Title</u>
	00 51 00	Notice of Award

00 52 13	Agreement Form – Stipulated Sum (Single-Prime Contract)
00 55 00	Notice to Proceed

**Project Forms**

<u>Division 0</u>	<u>Section</u>	<u>Title</u>
	00 61 13.13	Performance Bond
	00 61 13.16	Payment Bond
	00 63 57	Proposed Change Order Form
	00 63 63	Change Order Form
	00 65 36	Guarantee Form

**LIST OF DRAWINGS AND TABLES**

Stiern Middle School Spray Polyurethane Foam Roofing Project No. 26247.00-20-DM

The drawings are listed below:

<u>Sheet number</u>	<u>Title</u>
Attachment 1	Buildings
Attachment 2	Site Plan
Attachment D	Details
Attachment S	Construction Schedule
Attachment SP	Foam Roof Guide – Specifications
Attachment SOW	Scope of Work

END OF DOCUMENT



Walter W. Stiern  
Middle School

**Stiern Middle School**  
**Classrooms 701 - 710, Multi-Purpose, Music 901, 902**

MORNING DRIVE

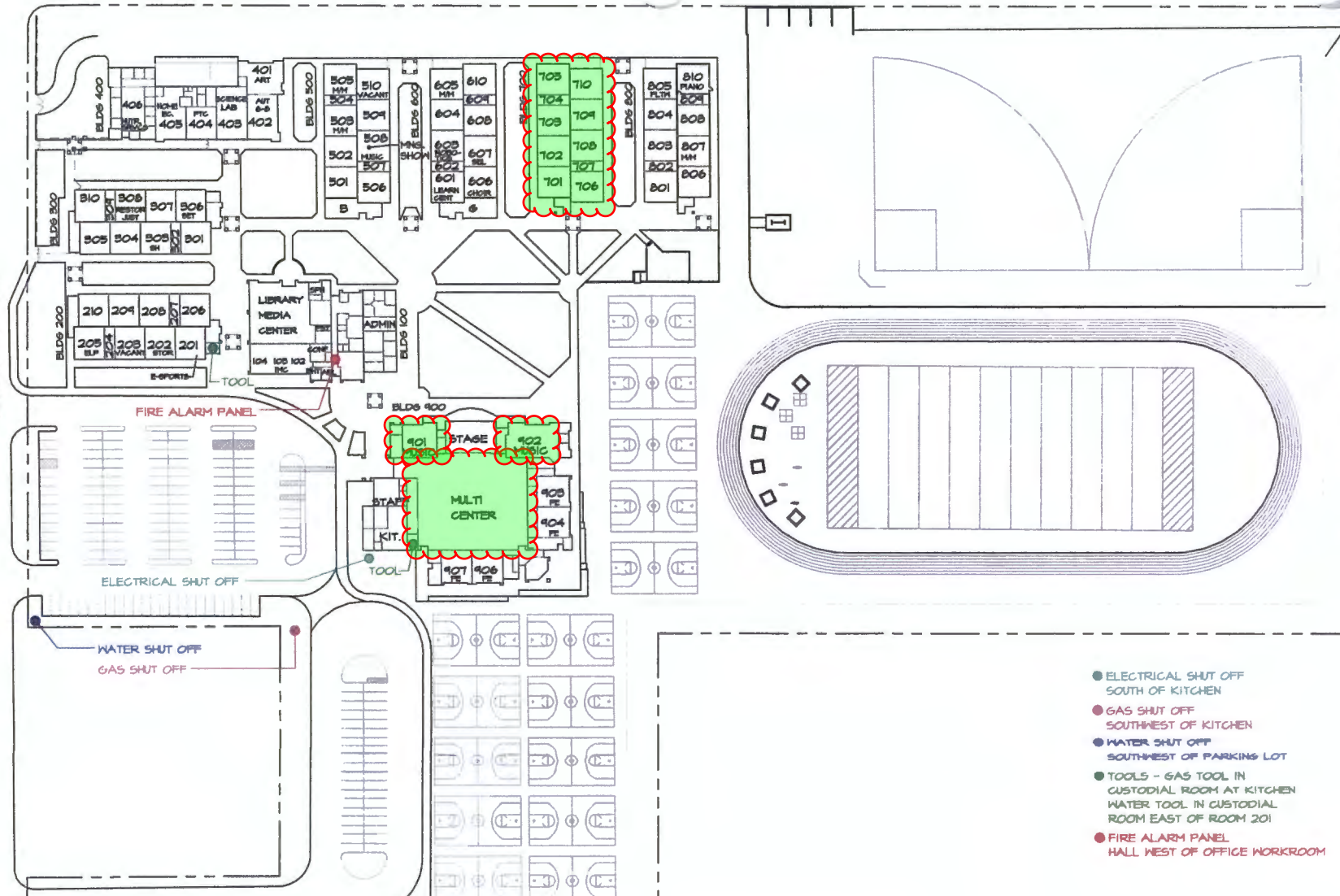

- ELECTRICAL SHUT OFF SOUTH OF KITCHEN
- GAS SHUT OFF SOUTHWEST OF KITCHEN
- WATER SHUT OFF SOUTHWEST OF PARKING LOT
- TOOLS - GAS TOOL IN CUSTODIAL ROOM AT KITCHEN  
WATER TOOL IN CUSTODIAL ROOM EAST OF ROOM 201
- FIRE ALARM PANEL HALL WEST OF OFFICE WORKROOM

**Stiern Middle School**  
**Classrooms 701 - 710, Multi-Purpose, Music 901, 902**

2551 MORNING DRIVE  
 631-5480



**SITE PLAN**  
**09-10-24**

SCALE: 1"=150'

## DETAIL 1, HVAC / EQUIPMENT PLATFORM

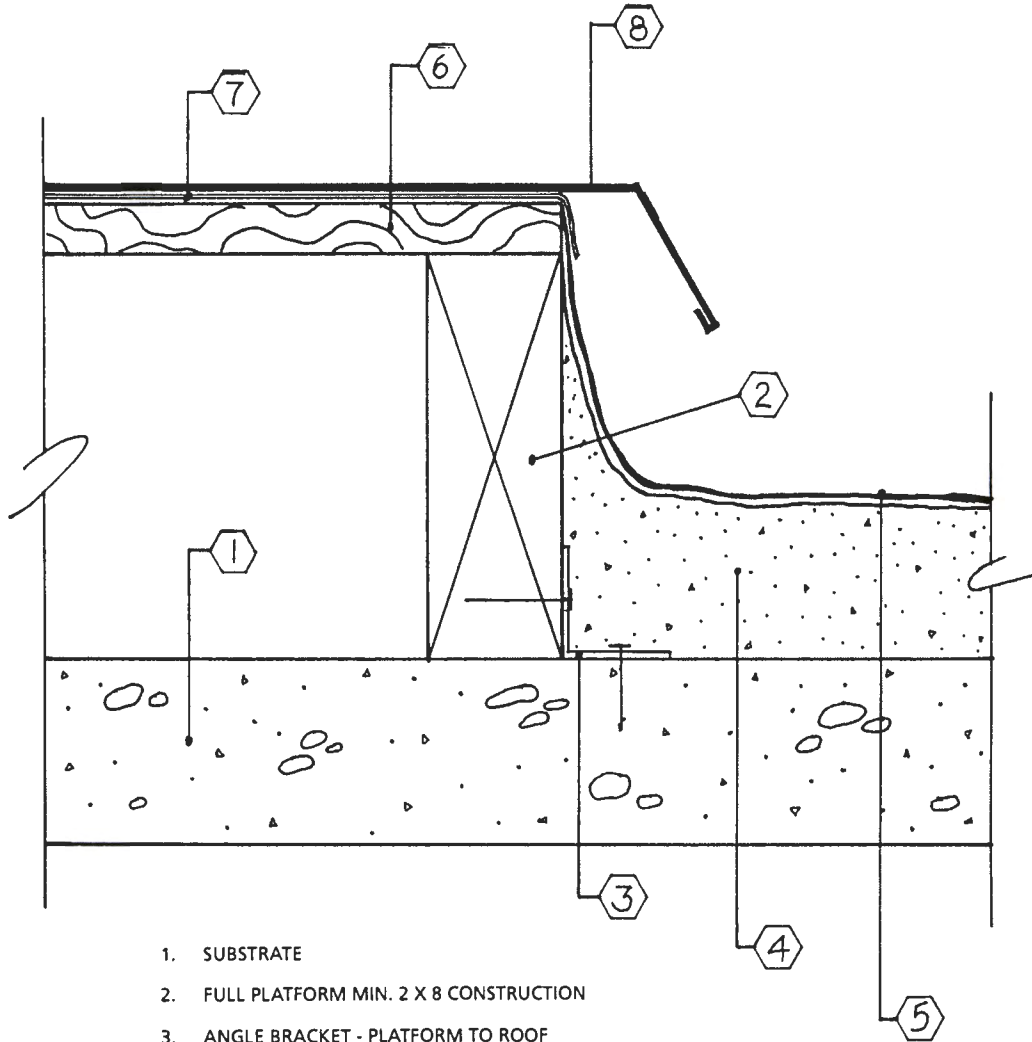

1. SUBSTRATE
2. FULL PLATFORM MIN. 2 X 8 CONSTRUCTION
3. ANGLE BRACKET - PLATFORM TO ROOF
4. SPRAYED POLYURETHANE INSULATION
5. ELASTOMERIC COATING SYSTEM (WITH GRANULE SURFACING)
6. MINIMUM 1/2 INCH PLYWOOD PLATFORM TOP
7. HENRY RUFTAC OR SINGLE PLY MEMBRANE
8. 24 GA. GALVANIZED SEAMLESS OR STANDING SEAM PLATFORM COVER

For Modification Call Resin Technology Co. 1-800-729-0795

## DETAIL 2, INTERNAL ROOF DRAIN

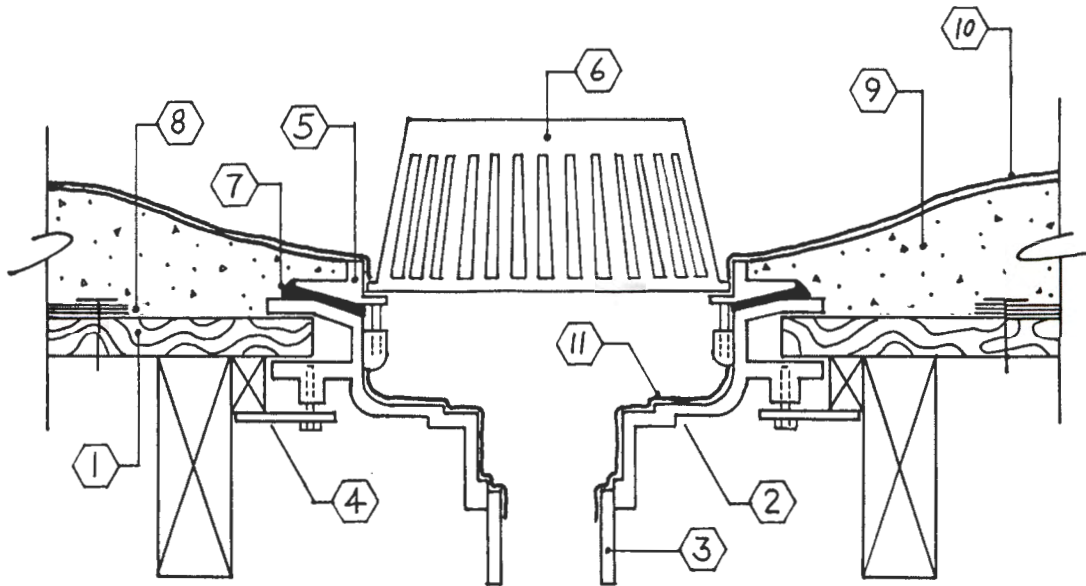

- |  |                  |
|--|------------------|
| 1. SUBSTRATE   | 4. DECK CLAMP    |
| 2. DRAIN BOWL  | 5. CLAMPING RING |
| 3. DRAIN PIPE  | 6. STRAINER      |
| 7. ELASTOMERIC SEALANT   |                  |
| 8. BUILT-UP ROOFING REMOVED MINIMUM 12 INCHES FROM DRAIN BOWL FLANGE. EGDE OF BUR TO BE MECHANICALLY ATTACHED TO SUBSTRATE |                  |
| 9. SPRAYED POLYURETHANE INSULATION   |                  |
| 10. ELASTOMERIC COATING SYSTEM WITH GRANULE SURFACING, DOUBLE COATING THICKNESS AROUND DRAIN AREA                          |                  |
| 11. RUN ELASTOMERIC COATING OVER CLAMPING RING AND INTO DRAIN BOWL   |                  |

For Modification Call Resin Technology Co. 1-800-729-0795

### DETAIL 3, LOWER ROOF ADJOINING WALL

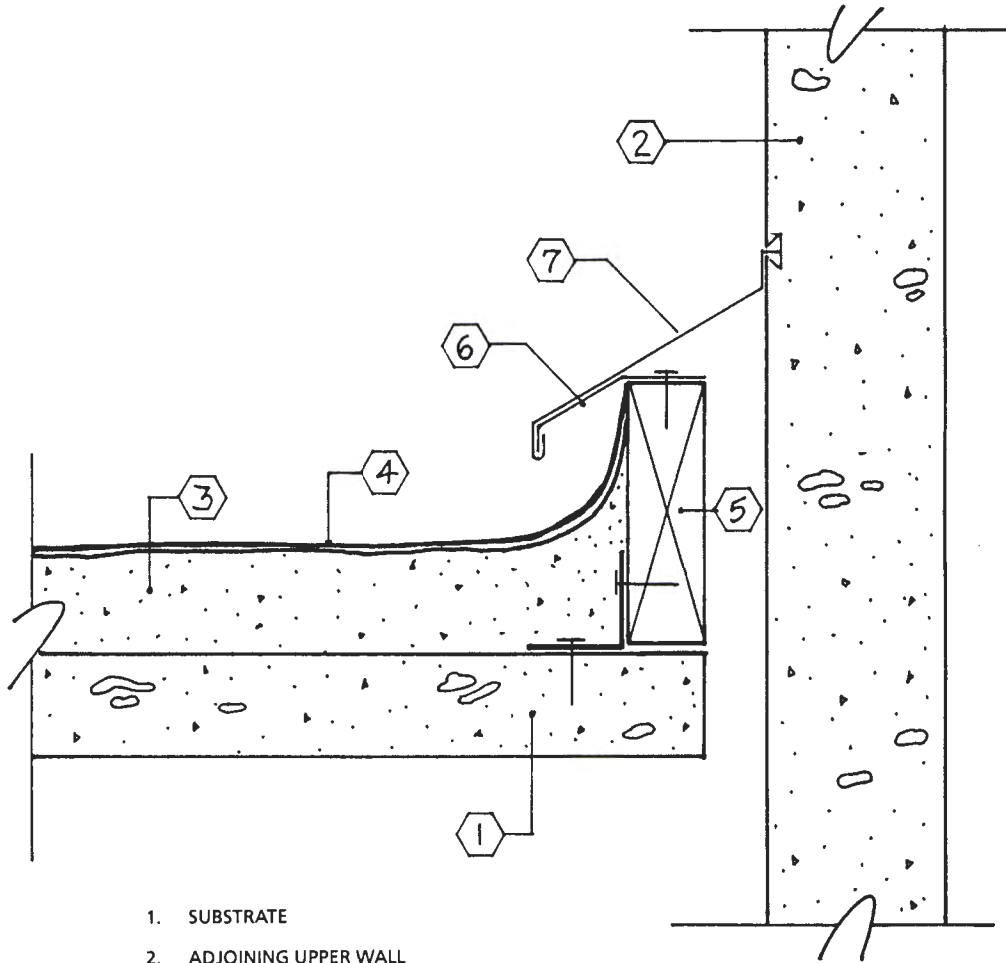

1. SUBSTRATE
2. ADJOINING UPPER WALL
3. SPRAYED POLYURETHANE INSULATION
4. ELASTOMERIC COATING SYSTEM (WITH GRANULE SURFACING)
5. TREATED WOOD NAILER MECHANICALLY ATTACHED TO SUBSTRATE
6. 20 GA. GALVINIZED CLEAT MECHANICALLY ATTACHED TO WOOD NAILER
7. 24 GA. GALVINIZED JOINT COVER

For Modification Call Resin Technology Co. 1-800-729-0795

## DETAIL 5, PARAPET WALL / PERIMETER EDGE METAL FLASHING

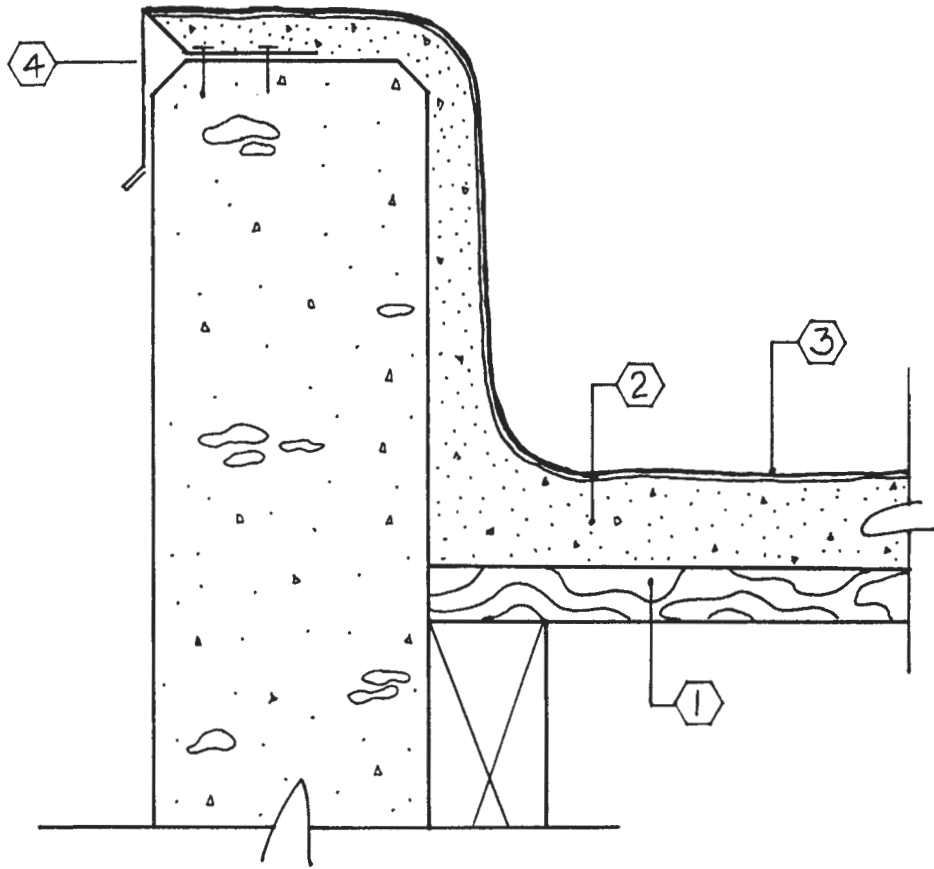

1. SUBSTRATE
2. SPRAYED POLYURETHANE INSULATION
3. ELASTOMERIC COATING SYSTEM (WITH GRANULE SURFACING)
4. 24 GA. GALVANIZED EDGE METAL MECHANICALLY ATTACHED WITH CONCRETE SCREWS OR EXPANDING FASTENERS MINIMUM 9 INCH ON CENTER

For Modification Call Resin Technology Co. 1-800-729-0795

## DETAIL 6, PARAPET WALL / WITH COPING

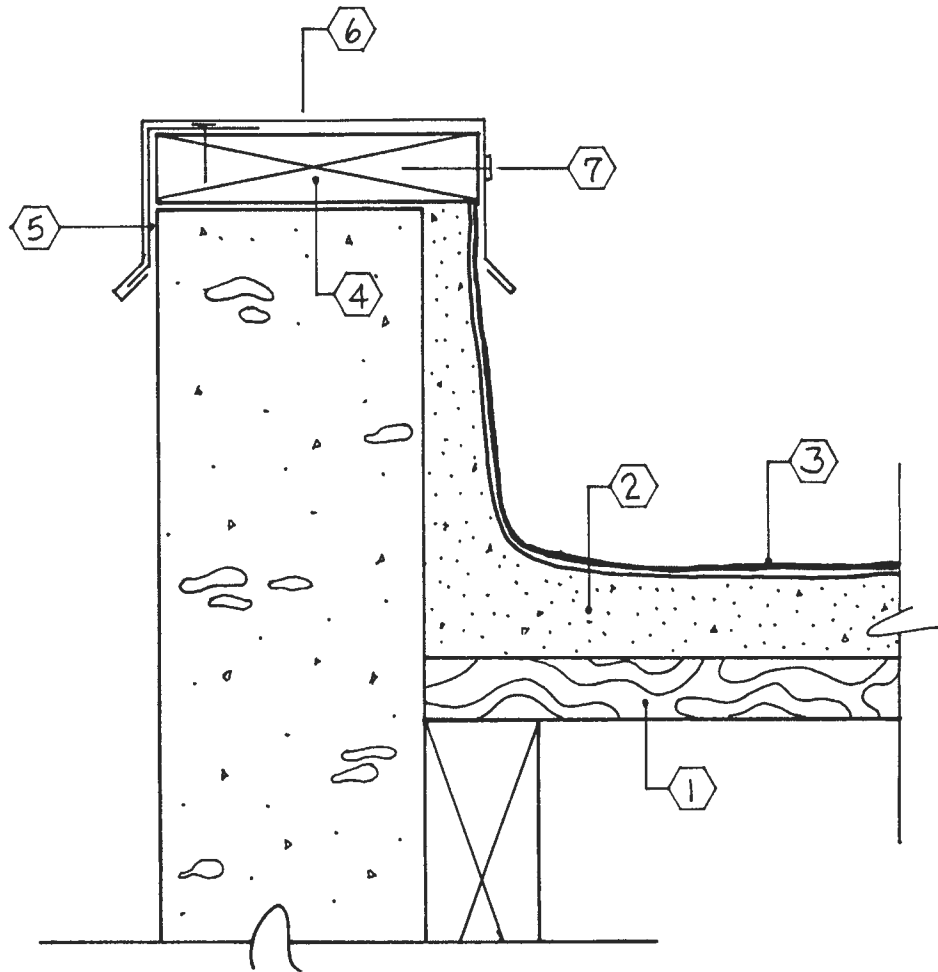

1. SUBSTRATE
2. SPRAYED POLYURETHANE INSULATION
3. ELASTOMERIC COATING SYSTEM (WITH GRANULE SURFACING)
4. TREATED WOOD NAILER MECHANICALLY ATTACHED TO TOP OF PARAPET
5. 22 GA. GALVANIZED CLEAT MECHANICALLY ATTACHED TO WOOD NAILER
6. 24 GA. GALVANIZED STANDING SEAM COPING
7. FASTENER WITH NEOPRENE/LEAD GASKET

For Modification Call Resin Technology Co. 1-800-729-0795

## DETAIL 7, THRU-WALL SCUPPER

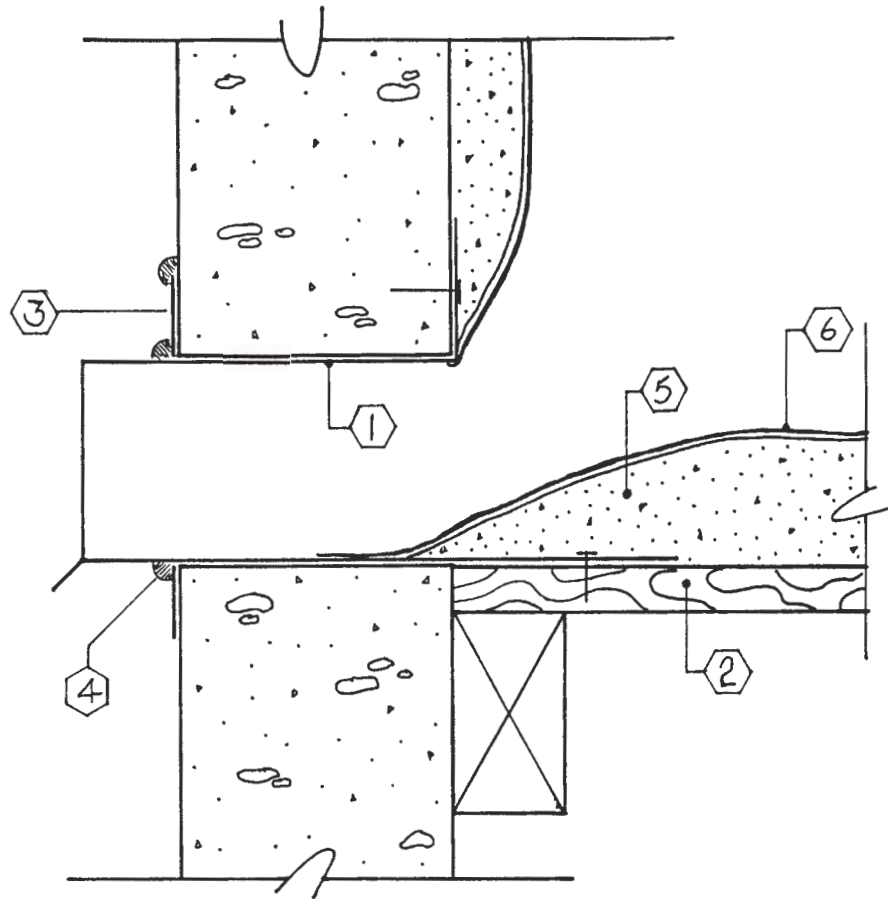

1. 24 GA. GALVANIZED SCUPPER ALL JOINTS SOLDERED
2. SUBSTRATE
3. EXTERIOR COVER PLATE
4. ELASTOMERIC CAULKING
5. SPRAYED POLYURETHANE INSULATION
6. ELASTOMERIC COATING SYSTEM (WITH GRANULE SURFACING)

NOTE: INSIDE OPENING NOT TO SCALE

For Modification Call Resin Technology Co. 1-800-729-0795

## DETAIL 8, GUY WIRE STANCHION

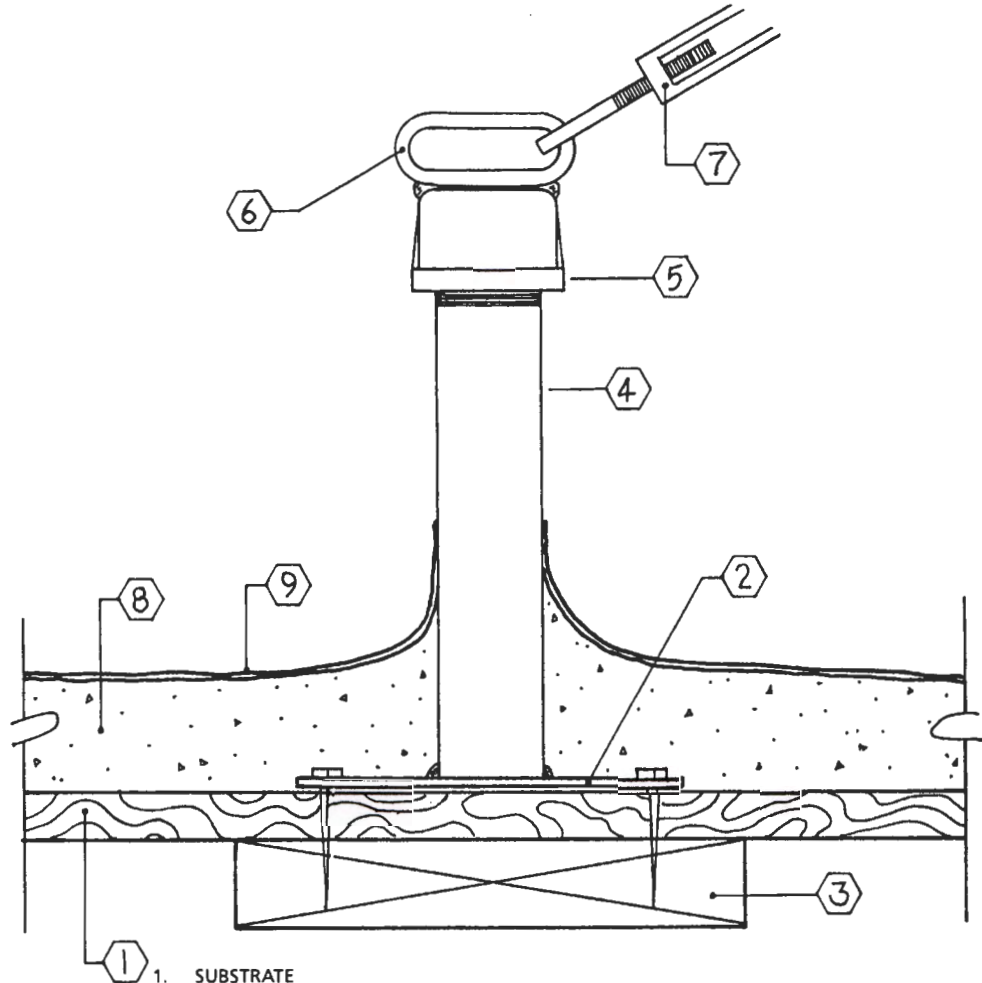

1. SUBSTRATE
2. MINIMUM 6" X 6" X 1/8" STEEL PLATE MECHANICALLY ATTACHED TO SUBSTRATE WITH LAG BOLTS OR THRU DECK BOLTS
3. STRUCTURAL MEMBER OR WOOD OR STEEL BACKING
4. MINIMUM 3/4" RISER PIPE WELDED TO PLATE
5. STANDARD PIPE CAP THREADED ONTO PIPE RISER
6. CHAIN LINK WELDED TO PIPE CAP
7. TURNBUCKLE ATTACHED TO PIPE RISER AND CABLE
8. SPRAYED POLYURETHANE INSULATION
9. ELASTOMERIC COATING SYSTEM (WITH GRANULE SURFACING)

For Modification Call Resin Technology Co. 1-800-729-0795

## DETAIL 9, CONDUIT AND PIPE SUPPORT

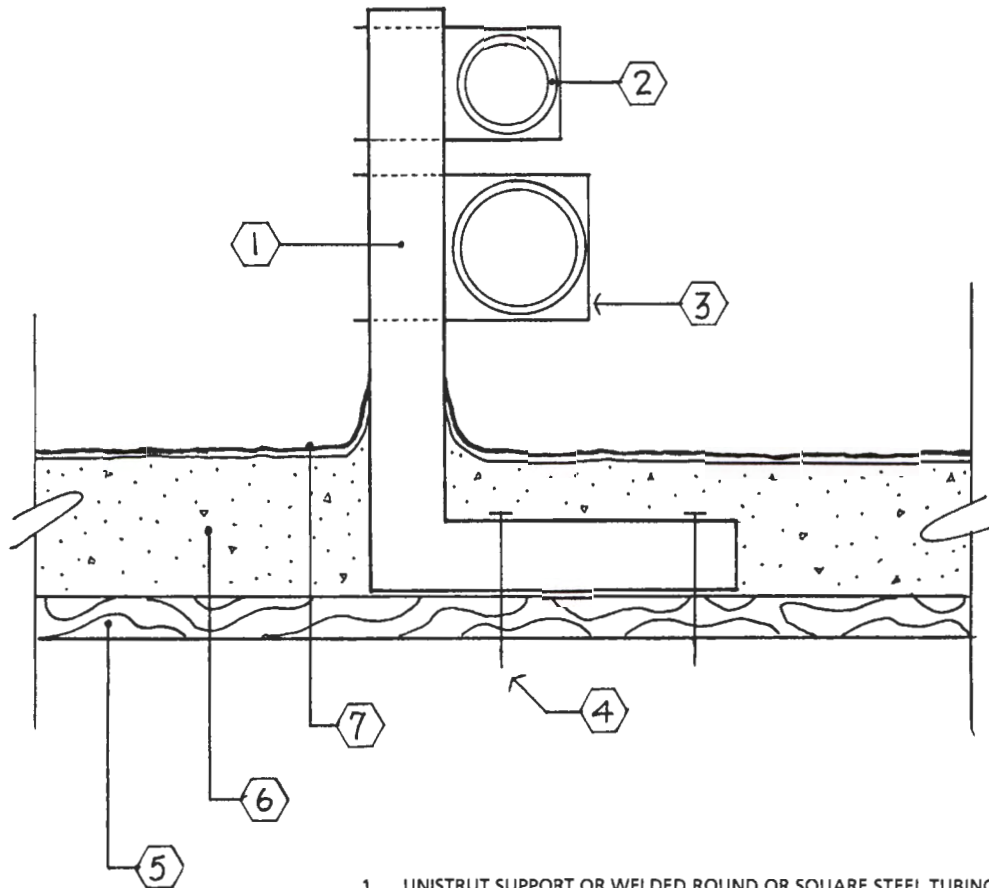

1. UNISTRUT SUPPORT OR WELDED ROUND OR SQUARE STEEL TUBING
2. CONDUIT OR PIPING
3. U-BOLT OR UNISTRUT FASTENER
4. BRACKET FASTENED TO DECK MAY REQUIRE UNDERSIDE BLOCKING
5. SUBSTRATE
6. SPRAYED POLYURETHANE INSULATION
7. ELASTOMERIC COATING SYSTEM (WITH GRANULE SURFACING)

For Modification Call Resin Technology Co. 1-800-729-0795

# DETAIL 12a - EXPANSION JOINT

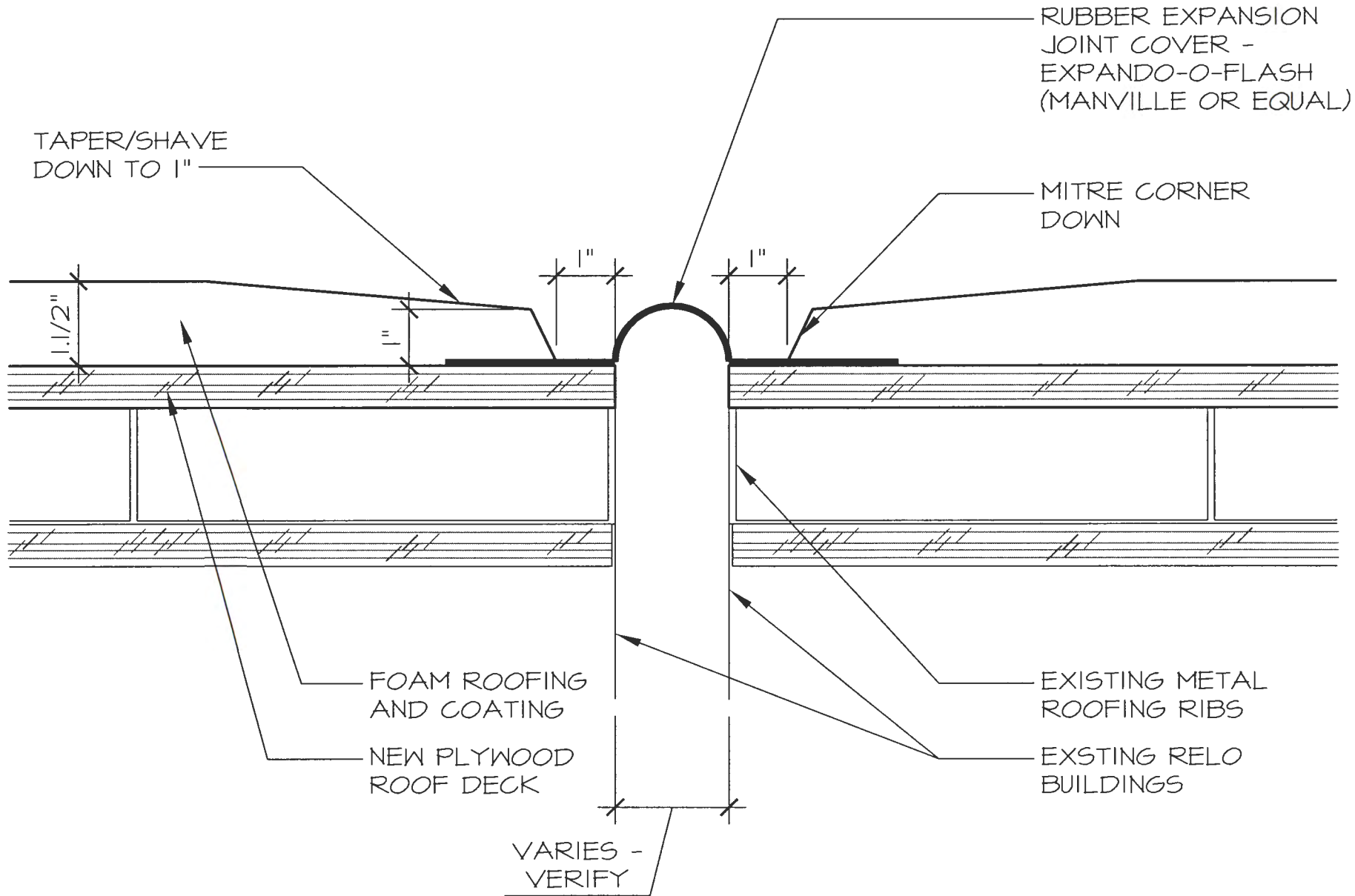

## DETAIL 13, ELECTRICAL BOX / WALL MOUNT

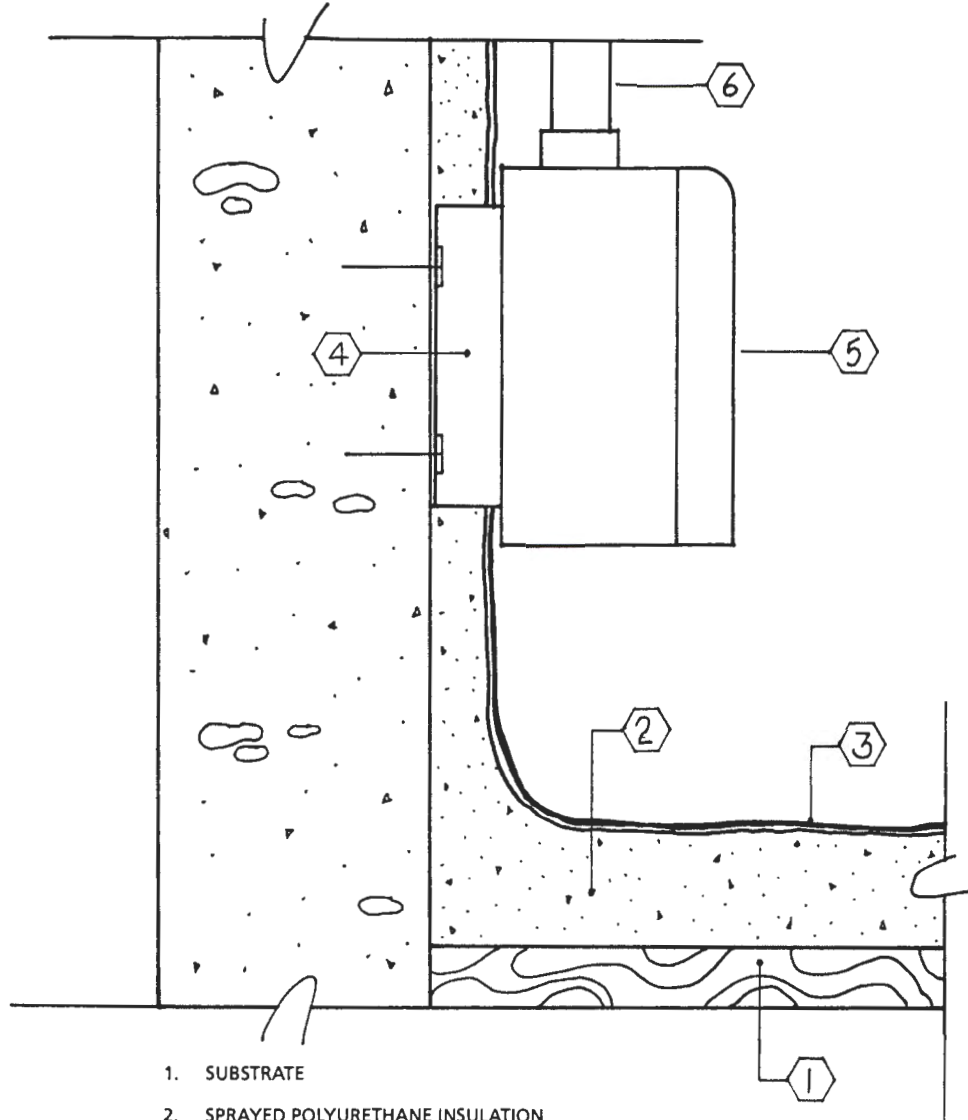

1. SUBSTRATE
2. SPRAYED POLYURETHANE INSULATION
3. ELASTOMERIC COATING SYSTEM (WITH GRANULE SURFACING)
4. UNISTRUT OR SQUARE STEEL TUBING SPACER MECHANICALLY ATTACHED TO WALL
5. ELECTRICAL BOX REMOVED FROM WALL AND MOUNTED ON SPACER
6. CONDUIT

For modification call Resin Technology Co. 1-800-729-0795

## DETAIL 14, WATER BLOCK

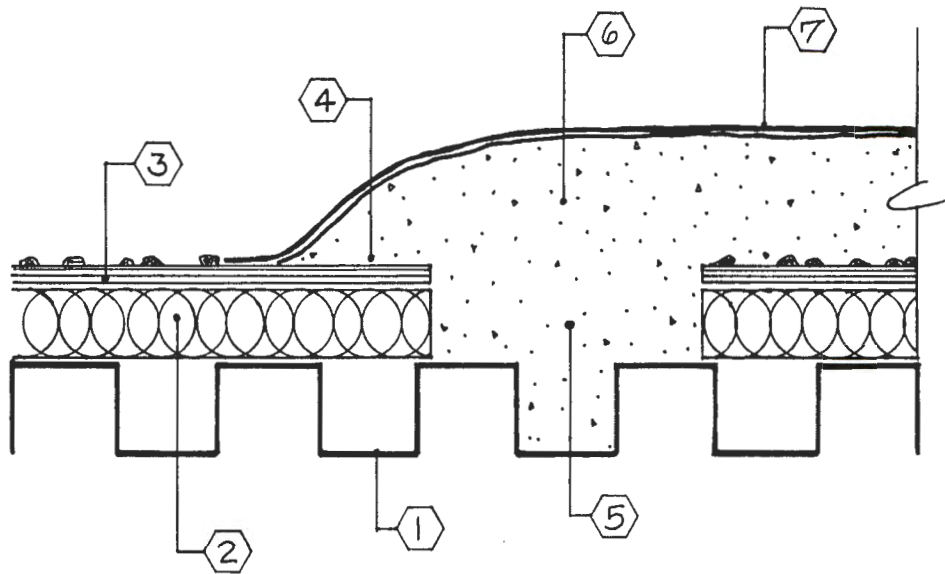

1. SUBSTRATE
2. RIGID BOARD INSULATION
3. BUILT-UP ROOF GRAVEL SURFACED
4. GRAVEL SURFACE REMOVED MINIMUM 12 INCHES
5. REMOVED INSULATION BOARD AND BUILT-UP ROOF MINIMUM 12 INCHES WIDE
6. SPRAYED POLYURETHANE INSULATION
7. ELASTOMERIC COATING SYSTEM (WITH GRANULE SURFACING)

For Modification Call Resin Technology Co. 1-800-729-0795

## DETAIL 15, STANDING SEAM DECK

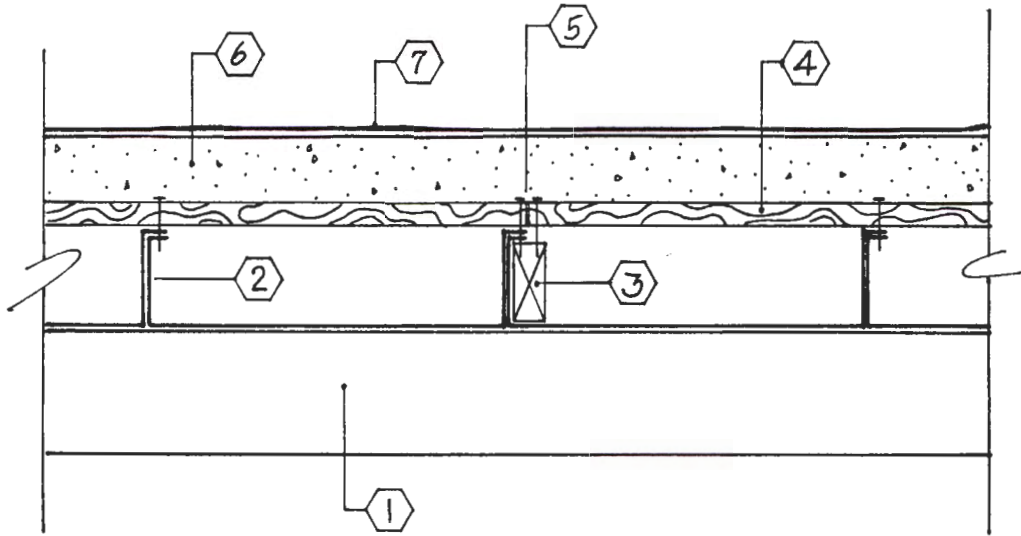

1. STRUCTURAL MEMBER
2. STANDING SEAM DECK
3. WOOD BACKING AT PLYWOOD JOINTS
4. 1/2 INCH "STRUCT-1" PLYWOOD (4-PLY)
5. MECHANICAL FASTENERS
6. SPRAYED POLYURETHANE INSULATION
7. ELASTOMERIC COATING SYSTEM (WITH GRANULE SURFACING)

For Modification Call Resin Technology Co. 1-800-729-0795

## DETAIL 16, STANDARD PERIMETER EDGE METAL FLASHING

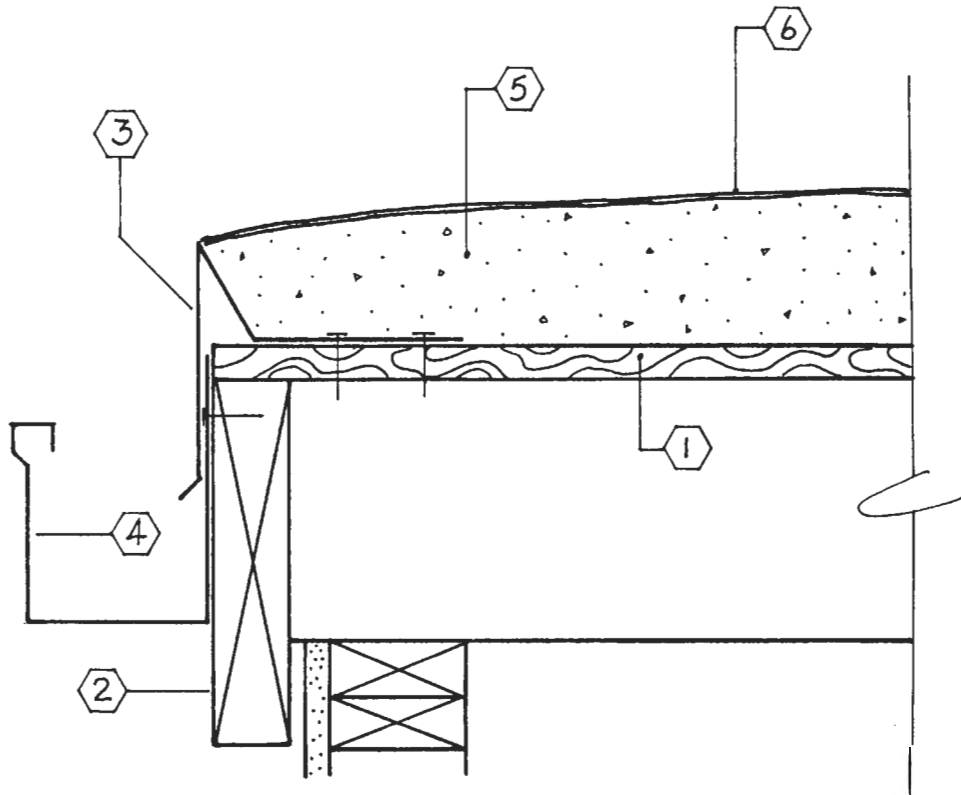

1. SUBSTRATE
2. FACIA
3. 24 GA. GALVANIZED EDGE METAL ATTACHED 4 INCH ON CENTER
4. MINIMUM 22 GA. GALVANIZED GUTTER GRADED (OPTIONAL)
5. SPRAYED POLYURETHANE INSULATION
6. ELASTOMERIC COATING SYSTEM (WITH GRANULE SURFACING)

For Modification Call Resin Technology Co. 1-800-729-0795



## DETAIL 18, PIPE PENETRATION

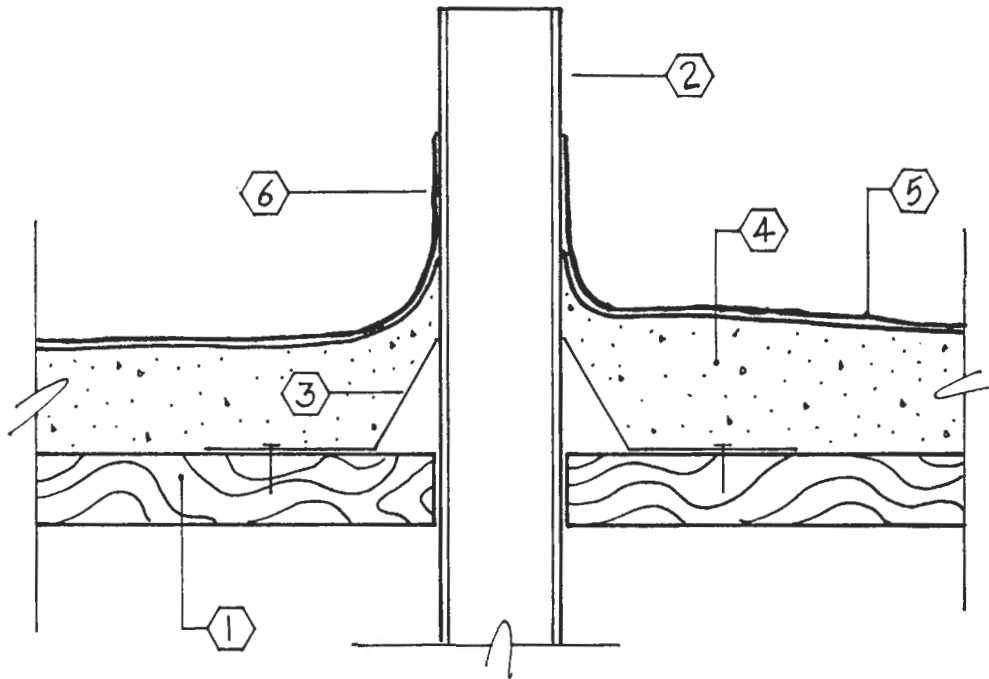

1. SUBSTRATE
2. SOIL PIPES
3. 24 GA. GALVANIZED STANDARD G.I. FLASHING
4. SPRAYED POLYURETHANE INSULATION
5. ELASTOMERIC COATING SYSTEM (WITH GRANULE SURFACING)
6. PROTECTIVE COATING TO EXTEND A MINIMUM 2 INCHES BEYOND INSULATION TERMINATION

For Modification Call Resin Technology Co. 1-800-729-0795

# ST-1 : FLASHING DETAIL

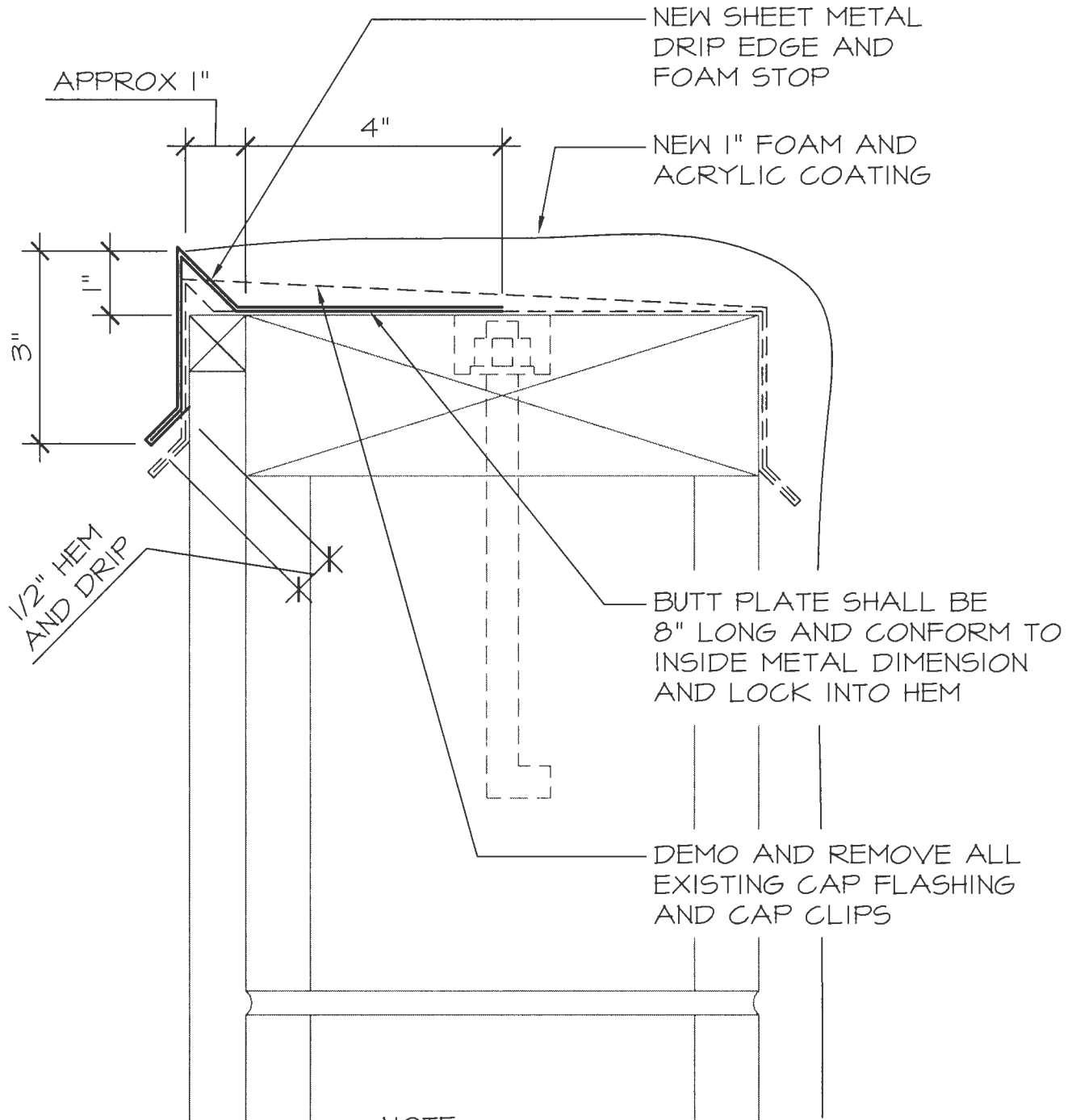

NOTE:  
ALL NEW MATERIALS  
SHALL BE 24 GA  
GALVANIZED



# BAKERSFIELD CITY SCHOOL DISTRICT

MAINTENANCE, OPERATIONS & FACILITIES  
1501 FELIZ DRIVE  
BAKERSFIELD, CALIFORNIA 93307  
(661) 631-5883 FAX: (661) 834-9986

**Jason Sitton, Director**  
[sittonj@bcasd.com](mailto:sittonj@bcasd.com)  
**Leonard Zasoski, Jr., Assistant Director**  
[zasoskil@bcasd.com](mailto:zasoskil@bcasd.com)  
**Daniel Wastaferrero, Assistant Director**  
[wastaferrero@bcasd.com](mailto:wastaferrero@bcasd.com)  
**Juan Montelongo, Assistant Director**  
[montelongoj@bcasd.com](mailto:montelongoj@bcasd.com)

**Education Center**  
1300 Baker Street  
Bakersfield, CA 93305  
Office: (661) 631-4600  
Fax: (661) 326-1485

## SPRAY POLYURETHANE FOAM (SPF) ROOF GUIDE SPECIFICATION

Attachment SP

### FULL SPF ROOFING APPLICATION

SPF ROOFING SYSTEM

ACRYLIC ELASTOMERIC ROOF COATING

FIFTEEN (15) YEAR CONTRACTOR RECOAT WARRANTY

#### 1.0 GENERAL REQUIREMENTS

##### 1.1 Terms and Conditions

- 1.1.1 The roofing contractor is the prime contractor. All subcontractors shall be identified and approved at the time the proposal is submitted. Manufacturers' installation procedures shall be the basis for accepting or rejecting actual workmanship.
- 1.1.2 Bidders shall be pre-qualified as follows:
  - a. All bidders shall be contractors who have specifically performed the application of sprayed-in-place polyurethane foam roofing systems. Such bidders shall have installed these systems for not less than ten years under the same contractor's name and license. Each bidder shall have performed at least fifteen applications of similar types and size. Bidders shall submit, with the bid, a list of projects including date of completion and contact information for verification.
  - b. The Contractor shall be a current member in good standing with the Spray Polyurethane Foam Alliance and Accreditation Program. A copy of the SPFA membership certification shall be submitted with the bid. Completion of the Roofing Master Installer and Fundamentals of Spray Polyurethane Foam and Coating Systems is the minimum acceptable status in the accreditation program by the supervisor(s) and spray mechanic(s) assigned to the project.
  - c. Each bidder shall submit a copy of the proposed Fifteen (15) Year Recoat Warranty along with the bid.

- d. The contractor shall carry a minimum of \$2,000,000 in general liability insurance on a continuing basis. Verification of insurance shall be submitted at the time of bid.
- e. The contractor shall submit, with the bid, a current license status printout from the Contractor's State License Board at <http://www.cslb.ca.gov> to demonstrate that the license is in good standing.
- f. Certification of the Manufacturer/Supplier: Submit, on corporate letterhead, a letter from the manufacturer supplier of the foam and from the supplier of the coating stating that the applicator of these products is qualified by the manufacturer supplier and meets sections 1.1.2 a and b.
- g. The contractor shall cooperate as required in performance of the specified inspecting and testing.
- h. Failure of the bidder to submit items A through F in its entirety with the bid will be deemed non-responsive.

1.1.3 Suppliers shall be pre-qualified as follows:

- a. The manufacturer of the foam and coating shall have been in business for a minimum of ten years and shall maintain a minimum of \$5,000,000 of product liability insurance on a continuing basis.
- b. The manufacturer of the foam and coating shall have a minimum of 3,000,000 square feet of roofing system installed.
- c. The foam and coating shall be listed as Class A over existing non-combustible roofing systems by Underwriters Laboratories per UL 790 at the thicknesses intended for use.
- d. The foam and coating shall be listed as Class B over existing combustible decks by Underwriters Laboratories per UL 790 at the thicknesses intended for use.
- e. Failure of the bidder to submit items A through D in their entirety will be deemed non-responsive.

1.2 Submittals

- 1.2.1 Manufacturer's Literature: Submit two copies of the manufacturer's data sheets regarding specifications, application information and safety information, and safety instructions on each product proposed for use.
- 1.2.2 Samples: Submit two samples of the proposed coating system applied on urethane foam. Samples shall be two inches by four inches in size.

- 1.2.3 UL follow up service: The foam and coating shall be registered under the UL follow up service and bear UL labels.
- 1.2.4 Contractors shall submit a computer-generated milestones schedule showing each specific phase of work along projected completion dates.

**2.0 MATERIALS AND EQUIPMENT**

2.2 Caulking or Sealants

Caulking materials shall be single-component polyurethane elastomers such as “Vulkem-921”, “Sikaflex-1a”, or approved equal. Roof field caulking shall be compatible with the respective elastomeric roof coating.

2.3 Polyurethane Foam: Polyurethane foam shall be a two-component polyurethane foam system formulated for use through airless equipment and manufactured by BASF.

Density (sprayed-in-place)	2.8-3.0 pcf min.
Compressive Strength	50-60 psi min.
Tensile Strength	70-75 psi min.
Shear Strength	50-60 psi min.
Closed Cell Content	95% min.
K Factor, Initial	0.11
Flame Spread (ASTM E84)	75 max.*
Roof Deck Classification:	ASTM E108 (UL 790)
Combustible Deck	Class B
Noncombustible Deck	Class A

\*This numerical flame spread rating is not intended to reflect hazards presented by this or any other material under actual fire conditions.

2.4 Acrylic rubber roof coating: The elastomeric coating shall be an acrylic elastomer coating and shall be Energy Star rated with the U.S. Environmental Protection Agency and California Title-24 Cool Roof Compliant.

Solids by Volume	56%
Solids by Weight	70%
Flash Point	>212°F
Initial Elongation (%)	310
Initial Tensile Strength	350 psi
Dry Adhesion	8.0 pli
Wet Adhesion	3 pli
Tear Resistance	130 lbf/in

1000 hr Accelerated Weathering	No Cracking or Checking
Elongation after Accelerated Weathering (%)	220
Low Temperature Flexibility after Accelerated Weathering	Pass
Permeance	19 perms
Water Swelling	6%
Fungi Resistance (zero = No Growth)	Zero Rating
Impact Resistance	>160
Tension Set @ 100%	0%
Durometer Hardness: Shore A	72

The minimum dry film thickness of the coating shall be 24 dry mils. Plasticized acrylics, vinyls, EVA's, terpolymers and PVA coatings shall not be considered.

- 2.6 Equipment: Equipment for spraying foam shall be manufactured specifically for the application of polyurethane foam. The equipment shall be airless, capable of maintaining a 1:1 volume ratio and have primary and hose heaters. Coating equipment shall be an airless type as recommended by the coating manufacturer.

### 3.0 SURFACE PREPARATION

Surface Condition: Identify and repair all leaks. The following areas are the most critical:

- a. Internal roof drains, scuppers and downspouts
- b. Edge detail, parapet walls and corner flashings
- c. Expansion joints, skylights, ductwork and air handling units
- d. Other roof penetrations such as soil pipes, ventilators and curbs

#### 3.1 Surface Condition

The owner shall ensure that roof top equipment does not discharge liquids onto the roof. All blowers shall exhaust into a container or the atmosphere and not onto the roof. The surface shall be free from solvent, grease, dust, sediment, dirt and sticky mastic.

- 3.2 All prepared surfaces to receive SPF roofing materials are to be primed with 1/3-1/2 gallon per 100 square feet using the appropriate primer as necessary.

- 3.3 All surfaces not to receive SPF roofing materials such as walls, shrubbery, pipe/conduit runs, windows, air conditioners and other roof mounted equipment shall be carefully masked with tape and paper to avoid overspray. Overspray shall be immediately

removed at the contractor's expense. **All coating shall be terminated in clean straight lines.**

- 3.4 Inspect the roof surface and establish the presence of any blisters or cracks in the existing insulation, or saturated or delaminated foam or coating areas. Remove the materials from all areas where temporary repairs have been made. Prime all areas to receive insulation. Flash all new penetrations with insulation. Spot repairs must be ground to match surrounding grade and sealed with acrylic elastomer.
- 3.5 If any of the existing SPF roofing system is to be scarified, remove the existing coating and approximately ¼ -inch of existing polyurethane foam by scarifying. Ensure that the remaining foam is clean, sound and dry. All scarified foam must be re-foamed at a minimum ½ -inch thickness and base coated the same day per manufacturer's recommendation. **There will be no exceptions.**
- 3.6 Remove all blisters to the deck and re-spray. Cracked, delaminated and saturated insulation shall be removed and the area re-sprayed. Grind all repairs to match the surrounding grade.
- 3.7 Repair all bird pecks and other mechanical damage by cutting away the damaged material or temporary repair materials and filling the void with a single component urethane caulking material per paragraph 2.2 above. Smooth the repaired area to conform to the surrounding roof grade.

Where the roofing system has failed or is damaged at existing perimeter edge metal, the edges may be repaired by trimming the damaged foam to sound foam and caulking and coating the repaired area.

Smooth the repaired area to conform to the surrounding roof grade.

#### **4.0 APPLICATION OF POLYURETHANE INSULATION**

- 4.1 Environmental Conditions
  - 4.1.1 Wind velocity shall not exceed 12 miles per hour.
  - 4.1.2 Application of spray insulation shall not proceed if ambient temperature is less than 50 degrees Fahrenheit or if the substrate temperature is less than 60 degrees Fahrenheit.
  - 4.1.3 Spray insulation shall not be applied over moist substrates or where rain or inclement weather is imminent.
- 4.2 Spray Application
  - 4.2.1 The polyurethane insulation shall be applied in minimum ½ inch lifts to a minimum thickness of one (1) inch over the existing scarified foam. **Additional foam thickness shall be applied to provide positive slope-to-drain as necessary.**
  - 4.2.2 The insulation surface shall be free from bumps, pinholes and ridges. The surface shall exhibit a smooth or "orange peel" surface texture. Surfaces resembling "popcorn" or "tree bark" shall be deemed unacceptable.

#### **5.0 APPLICATION OF FLUID APPLIED PROTECTIVE COATING**

## 5.1 General

Sprayed polyurethane insulation must be protected from ultraviolet light in order to avoid degradation of the polymer. Coating also protects the insulation from water and adverse weather conditions. Coatings must be specifically formulated for use over sprayed polyurethane insulation.

### Elastomeric Coating

The roof perimeter shall be coated in a picture frame fashion and backrolled. The coating is then to be applied to the properly prepared surface of the roof in two (2) uniform passes. The **base coat** shall be **off-white** in color and shall be applied at the rate of **2 gallons** per 100 square feet, backrolled, and allowed to cure. The **topcoat** shall be **white** in color and shall be applied at the rate of **2 gallons** per 100 square feet.

Broadcast 3M C-93 ceramic roofing granules into the wet topcoat at the rate of 40 lbs. per 100 square feet, or to the point of refusal. Remove all loose granules after the coating has cured.

## 6.0 WARRANTY AND CERTIFICATION

The contractor shall issue a Fifteen (15) year non-depreciating full system recoat warranty.

## 7.0 INSPECTION

A representative from the materials manufacturer and contractor shall inspect the roof after completion to ensure that the work has been completed in conformance with the specification and accepted industry practice. All material thickness shall be verified.

## 8.0 CLEAN UP

Upon completion of all work covered in this specification, the contractor shall remove all equipment, material and debris, leaving the area undamaged and in acceptable condition.



# BAKERSFIELD CITY SCHOOL DISTRICT

MAINTENANCE, OPERATIONS & FACILITIES  
1501 FELIZ DRIVE  
BAKERSFIELD, CALIFORNIA 93307  
(661) 631-5883 FAX: (661) 834-9986

**Jason Sitton, Director**  
[sittonj@bcasd.com](mailto:sittonj@bcasd.com)  
**Leonard Zasoski, Jr., Assistant Director**  
[zasoskil@bcasd.com](mailto:zasoskil@bcasd.com)  
**Daniel Wastafarro, Assistant Director**  
[wastafarro@bcasd.com](mailto:wastafarro@bcasd.com)  
**Juan Montelongo, Assistant Director**  
[montelongoj@bcasd.com](mailto:montelongoj@bcasd.com)

**Education Center**  
1300 Baker Street  
Bakersfield, CA 93305  
Office: (661) 631-4600  
Fax: (661) 326-1485

## Spray Polyurethane Foam (SPF) Roofing Project Scope of Work

### Stiern Middle School

Address: 2551 Morning Drive Bakersfield, CA 93306

### Buildings 700 & 900 (Rooms 701-710, Multi-Purpose, 901, 902)

- Install new polyurethane foam and elastomeric coating to the existing roof at Buildings 700 & 900 (Rooms 701-710, Multi-Purpose, 901, 902).
- Install 1" thick Polyurethane Foam.
- Install elastomeric coatings over new polyurethane foam.
- Install 3M Artic white roofing granules to final coat.
- Provide a 15-year full warranty.
- Repair any damaged roof surfaces prior to the installation of the 1" foam and elastomeric coating per attached specifications and job walk.
- Remove all resultant debris.
- If one contractor secures more than one project and if schedules of work and completions overlap, successful contractors will be required to provide materials and labor to ensure that all projects are completed on schedule.
- It is the Contractor's responsibility to verify all linear/square footages and quantities.
- Working hours are from 6:00 a.m. through 2:30 p.m. (8 hrs.).
- See attachment P indicating the building to receive the polyurethane foam and elastomeric coating.
- See attachment S showing a schedule of all sites receiving roof coatings.
- See attachment A Foam Roof Guide – Specifications.
- Multi-Purpose, 901, 902: INSTALLATION OF MATERIALS AND LABOR MUST BE COMPLETE NO LATER THAN JUNE 30<sup>TH</sup>

The following details indicate the methods of which to install the foam and coating at various locations on the roofs.

Detail 1 – HVAC/Equipment Platform

Detail 2 – Internal Roof Drain

Detail 3 – Lower Roof Adjoining Wall

Detail 5 – Parapet Wall/Perimeter Edge Metal Flashing

Detail 6 – Parapet Wall with Coping

Detail 7 – Thru-Wall Scupper

Detail 8 – Guy Wire Stanchion

Detail 9 – Conduit and Pipe Support

Detail 12a – Expansion Joint

Detail 13 – Electrical Box / Wall Mount

Detail 14 – Water Block

Detail 15 – Standing Seam Deck

Detail 16 – Standard Perimeter Edge Metal Flashing

Detail 17 – Perimeter Edge Metal Flashing Raised Edge

Detail 18 – Pipe penetration

Detail ST-1 – Flashing Detail

DOCUMENT 00 01 20

**LIST OF SCHEDULES**

**SCHEDULES**

1. Refer to attached Stiern Middle School Spray Polyurethane Foam Roofing – Schedule dated 3/02/26.

END OF DOCUMENT

# Bakersfield City School District

## Roofing Projects @ Various Sites

# Attachment "S"



Activity ID	Act. Assignment	Activity Name	Start	Finish	Original Duration	Calendar											
						M	April 2026	May 2026	June 2026	July 2026	A	S	O	N	D	J	
<b>Roofing Projects @ Various Sites 2026</b>						27-Aug-26, Roofing Projects @ Various Sites 2026											
<b>Pre-Construction Activities</b>						15-Jul-26, Pre-Construction Activities											
PCA-900	BCSD	Advertise Projects	02-Mar-26	02-Mar-26	1	Advertise Projects											
PCA-910	Contractors	Bid Projects	03-Mar-26	17-Mar-26	11	Bid Projects											
PCA-920	Contractors	Non-Mandatory Job Walk - 1 (Sierra, Hort, Stiern, Nichols, Jefferson)	10-Mar-26	10-Mar-26	1	Non-Mandatory Job Walk - 1 (Sierra, Hort, Stiern, Nichols, Jefferson)											
PCA-930	Contractors	Non-Mandatory Job Walk - 2 (Longfellow, Lincoln, Owens, Fremont, Rafer)	11-Mar-26	11-Mar-26	1	Non-Mandatory Job Walk - 2 (Longfellow, Lincoln, Owens, Fremont, Rafer)											
PCA-1000	Contractors	Separate Bids Due for Each Site	18-Mar-26	18-Mar-26	1	Separate Bids Due for Each Site											
PCA-1010	BCSD	Review Bids for Each Site	19-Mar-26	20-Mar-26	2	Review Bids for Each Site											
PCA-1020	BCSD	Notice to Award Bid for Each Site	23-Mar-26	23-Mar-26	1	Notice to Award Bid for Each Site											
PCA-1040	Contractors	Start Submittal Process - All Sites	24-Mar-26		0	Start Submittal Process - All Sites											
PCA-1060	BCSD	Notice to Proceed - All Sites	07-Apr-26	07-Apr-26	1	Notice to Proceed - All Sites											
PCA-1050	Contractors	Pre-Construction Meeting - All Sites	05-May-26*	05-May-26	1	Pre-Construction Meeting - All Sites											
<b>Contracts &amp; Insurance</b>						06-Apr-26, Contracts & Insurance											
<b>Fremont Elementary School</b>						06-Apr-26, Fremont Elementary School											
FCI-1000	Contractors	Contracts & Insurance	24-Mar-26	06-Apr-26	10	Contracts & Insurance											
<b>Hort Elementary School</b>						06-Apr-26, Hort Elementary School											
HCI-1000	Contractors	Contracts & Insurance	24-Mar-26	06-Apr-26	10	Contracts & Insurance											
<b>Jefferson Elementary School</b>						06-Apr-26, Jefferson Elementary School											
JCI-1000	Contractors	Contracts & Insurance	24-Mar-26	06-Apr-26	10	Contracts & Insurance											
<b>Lincoln Jr. High School</b>						06-Apr-26, Lincoln Jr. High School											
LCI-1000	Contractors	Contracts & Insurance	24-Mar-26	06-Apr-26	10	Contracts & Insurance											
<b>Nichols Elementary School</b>						06-Apr-26, Nichols Elementary School											
NCI-1000	Contractors	Contracts & Insurance	24-Mar-26	06-Apr-26	10	Contracts & Insurance											
<b>Stiern Middle School</b>						06-Apr-26, Stiern Middle School											
STCI-1000	Contractors	Contracts & Insurance	24-Mar-26	06-Apr-26	10	Contracts & Insurance											
<b>Owens Elementary School</b>						06-Apr-26, Owens Elementary School											
OCI-1000	Contractors	Contracts & Insurance	24-Mar-26	06-Apr-26	10	Contracts & Insurance											
<b>Rafer Community School</b>						06-Apr-26, Rafer Community School											

█ Actual Work   
 █ Critical Remaining Work   
  Summary  
█ Remaining Work   
 ◆ Milestone

Date	Revision	Checked	Approved
02-Mar-26	Baseline - Bid Schedule		

# Bakersfield City School District

## Roofing Projects @ Various Sites

# Attachment "S"



Activity ID	Act. Assignment	Activity Name	Start	Finish	Original Duration	Calendar											
						M	April 2026	May 2026	June 2026	July 2026	A	S	O	N	D	J	
RCI-1050	Contractors	Contracts & Insurance	24-Mar-26	06-Apr-26	10	Contracts & Insurance 06-Apr-26, Longfellow Elementary School											
<b>Longfellow Elementary School</b>			24-Mar-26	06-Apr-26	10												
LCI-1060	Contractors	Contracts & Insurance	24-Mar-26	06-Apr-26	10	Contracts & Insurance 06-Apr-26, Sierra Middle School											
<b>Sierra Middle School</b>			24-Mar-26	06-Apr-26	10												
SICI-1070	Contractors	Contracts & Insurance	24-Mar-26	06-Apr-26	10	Contracts & Insurance 15-Jul-26, Submittals											
<b>Submittals</b>			24-Mar-26	15-Jul-26	80												
<b>Fremont Elementary School</b>			24-Mar-26	21-May-26	43	Manufacture's Literature / Product Samples (Contractor Provide Submittal Items) Manufacture's Literature / Product Samples (BCSD Approve Submittals) Roofing Materials (Contractor Procure Materials) 21-May-26, Fremont Elementary School											
FSUB-1000	Contractors	Manufacture's Literature / Product Samples (Contractor Provide Submittal Items)	24-Mar-26	06-Apr-26	10												
FSUB-1010	BCSD	Manufacture's Literature / Product Samples (BCSD Approve Submittals)	07-Apr-26	13-Apr-26	5												
FSUB-1020	Contractors	Roofing Materials (Contractor Procure Materials)	01-May-26	21-May-26	15												
<b>Hort Elementary School</b>			24-Mar-26	26-May-26	45	Manufacture's Literature / Product Samples (Contractor Provide Submittal Items) Manufacture's Literature / Product Samples (BCSD Approve Submittals) Roofing Materials (Contractor Procure Materials) 26-May-26, Hort Elementary School											
HSUB-1000	Contractors	Manufacture's Literature / Product Samples (Contractor Provide Submittal Items)	24-Mar-26	06-Apr-26	10												
HSUB-1010	BCSD	Manufacture's Literature / Product Samples (BCSD Approve Submittals)	07-Apr-26	13-Apr-26	5												
HSUB-1020	Contractors	Roofing Materials (Contractor Procure Materials)	05-May-26	26-May-26	15												
<b>Jefferson Elementary School</b>			24-Mar-26	28-May-26	47	Manufacture's Literature / Product Samples (Contractor Provide Submittal Items) Manufacture's Literature / Product Samples (BCSD Approve Submittals) Roofing Materials (Contractor Procure Materials) 28-May-26, Jefferson Elementary School											
JSUB-1000	Contractors	Manufacture's Literature / Product Samples (Contractor Provide Submittal Items)	24-Mar-26	06-Apr-26	10												
JSUB-1010	BCSD	Manufacture's Literature / Product Samples (BCSD Approve Submittals)	07-Apr-26	13-Apr-26	5												
JSUB-1020	Contractors	Roofing Materials (Contractor Procure Materials)	07-May-26	28-May-26	15												
<b>Lincoln Jr. High School</b>			24-Mar-26	01-Jun-26	49	Manufacture's Literature / Product Samples (Contractor Provide Submittal Items) Manufacture's Literature / Product Samples (BCSD Approve Submittals) Roofing Materials (Contractor Procure Materials) 01-Jun-26, Lincoln Jr. High School											
LISUB-1000	Contractors	Manufacture's Literature / Product Samples (Contractor Provide Submittal Items)	24-Mar-26	06-Apr-26	10												
LISUB-1010	BCSD	Manufacture's Literature / Product Samples (BCSD Approve Submittals)	07-Apr-26	13-Apr-26	5												
LISUB-1020	Contractors	Roofing Materials (Contractor Procure Materials)	11-May-26	01-Jun-26	15												
<b>Nichols Elementary School</b>			24-Mar-26	03-Jun-26	51	Manufacture's Literature / Product Samples (Contractor Provide Submittal Items) Manufacture's Literature / Product Samples (BCSD Approve Submittals) Roofing Materials (Contractor Procure Materials) 03-Jun-26, Nichols Elementary School											
NSUB-1000	Contractors	Manufacture's Literature / Product Samples (Contractor Provide Submittal Items)	24-Mar-26	06-Apr-26	10												
NSUB-1010	BCSD	Manufacture's Literature / Product Samples (BCSD Approve Submittals)	07-Apr-26	13-Apr-26	5												
NSUB-1020	Contractors	Roofing Materials (Contractor Procure Materials)	13-May-26	03-Jun-26	15												
<b>Stiern Middle School</b>			24-Mar-26	05-Jun-26	53	05-Jun-26, Stiern Middle School											

█ Actual Work   
 █ Critical Remaining Work   
 Summary  
█ Remaining Work   
 ◆ Milestone

Date	Revision	Checked	Approved
02-Mar-26	Baseline - Bid Schedule		

**Bakersfield City School District**  
**Roofing Projects @ Various Sites**

**Attachment "S"**



Activity ID	Act. Assignment	Activity Name	Start	Finish	Original Duration	Calendar											
						M	April 2026	May 2026	June 2026	July 2026	A	S	O	N	D	J	
STSUB-1000	Contractors	Manufacture's Literature / Product Samples (Contractor Provide Submittal Items)	24-Mar-26	06-Apr-26	10	[Gantt bar: 24-Mar-26 to 06-Apr-26] Manufacture's Literature / Product Samples (Contractor Provide Submittal Items)											
STSUB-1010	BCSD	Manufacture's Literature / Product Samples (BCSD Approve Submittals)	07-Apr-26	13-Apr-26	5	[Gantt bar: 07-Apr-26 to 13-Apr-26] Manufacture's Literature / Product Samples (BCSD Approve Submittals)											
STSUB-1020	Contractors	Roofing Materials (Contractor Procure Materials)	15-May-26	05-Jun-26	15	[Gantt bar: 15-May-26 to 05-Jun-26] Roofing Materials (Contractor Procure Materials)											
<b>Owens Elementary School</b>			<b>24-Mar-26</b>	<b>26-Jun-26</b>	<b>68</b>	[Summary bar: 24-Mar-26 to 26-Jun-26] Owens Elementary School											
OSUB-1000	Contractors	Manufacture's Literature / Product Samples (Contractor Provide Submittal Items)	24-Mar-26	06-Apr-26	10	[Gantt bar: 24-Mar-26 to 06-Apr-26] Manufacture's Literature / Product Samples (Contractor Provide Submittal Items)											
OSUB-1010	BCSD	Manufacture's Literature / Product Samples (BCSD Approve Submittals)	07-Apr-26	13-Apr-26	5	[Gantt bar: 07-Apr-26 to 13-Apr-26] Manufacture's Literature / Product Samples (BCSD Approve Submittals)											
OSUB-1020	Contractors	Roofing Materials (Contractor Procure Materials)	08-Jun-26	26-Jun-26	15	[Gantt bar: 08-Jun-26 to 26-Jun-26] Roofing Materials (Contractor Procure Materials)											
<b>Rafer Community School</b>			<b>24-Mar-26</b>	<b>02-Jul-26</b>	<b>72</b>	[Summary bar: 24-Mar-26 to 02-Jul-26] Rafer Community School											
RSUB-1000	Contractors	Manufacture's Literature / Product Samples (Contractor Provide Submittal Items)	24-Mar-26	06-Apr-26	10	[Gantt bar: 24-Mar-26 to 06-Apr-26] Manufacture's Literature / Product Samples (Contractor Provide Submittal Items)											
RSUB-1010	BCSD	Manufacture's Literature / Product Samples (BCSD Approve Submittals)	07-Apr-26	13-Apr-26	5	[Gantt bar: 07-Apr-26 to 13-Apr-26] Manufacture's Literature / Product Samples (BCSD Approve Submittals)											
RSUB-1020	Contractors	Roofing Materials (Contractor Procure Materials)	12-Jun-26	02-Jul-26	15	[Gantt bar: 12-Jun-26 to 02-Jul-26] Roofing Materials (Contractor Procure Materials)											
<b>Longfellow Elementary School</b>			<b>24-Mar-26</b>	<b>09-Jul-26</b>	<b>76</b>	[Summary bar: 24-Mar-26 to 09-Jul-26] Longfellow Elementary School											
LOSUB-1000	Contractors	Manufacture's Literature / Product Samples (Contractor Provide Submittal Items)	24-Mar-26	06-Apr-26	10	[Gantt bar: 24-Mar-26 to 06-Apr-26] Manufacture's Literature / Product Samples (Contractor Provide Submittal Items)											
LOSUB-1010	BCSD	Manufacture's Literature / Product Samples (BCSD Approve Submittals)	07-Apr-26	13-Apr-26	5	[Gantt bar: 07-Apr-26 to 13-Apr-26] Manufacture's Literature / Product Samples (BCSD Approve Submittals)											
LOSUB-1020	Contractors	Roofing Materials (Contractor Procure Materials)	18-Jun-26	09-Jul-26	15	[Gantt bar: 18-Jun-26 to 09-Jul-26] Roofing Materials (Contractor Procure Materials)											
<b>Sierra Middle School</b>			<b>24-Mar-26</b>	<b>15-Jul-26</b>	<b>80</b>	[Summary bar: 24-Mar-26 to 15-Jul-26] Sierra Middle School											
SISUB-1000	Contractors	Manufacture's Literature / Product Samples (Contractor Provide Submittal Items)	24-Mar-26	06-Apr-26	10	[Gantt bar: 24-Mar-26 to 06-Apr-26] Manufacture's Literature / Product Samples (Contractor Provide Submittal Items)											
SISUB-1010	BCSD	Manufacture's Literature / Product Samples (BCSD Approve Submittals)	07-Apr-26	13-Apr-26	5	[Gantt bar: 07-Apr-26 to 13-Apr-26] Manufacture's Literature / Product Samples (BCSD Approve Submittals)											
SISUB-1020	Contractors	Roofing Materials (Contractor Procure Materials)	24-Jun-26	15-Jul-26	15	[Gantt bar: 24-Jun-26 to 15-Jul-26] Roofing Materials (Contractor Procure Materials)											
<b>Construction Activities</b>			<b>01-Jun-26</b>	<b>27-Aug-26</b>	<b>63</b>	[Summary bar: 01-Jun-26 to 27-Aug-26] Construction Activities											
<b>June 2026 Sites</b>			<b>01-Jun-26</b>	<b>30-Jun-26</b>	<b>22</b>	[Summary bar: 01-Jun-26 to 30-Jun-26] June 2026 Sites											
<b>Fremont Elementary School (Roof Recoat @ MPR &amp; Kitchen)</b>			<b>01-Jun-26</b>	<b>30-Jun-26</b>	<b>22</b>	[Summary bar: 01-Jun-26 to 30-Jun-26] Fremont Elementary School (Roof Recoat @ MPR & Kitchen)											
FRC-1000	General	Start Project	01-Jun-26*		0	[Milestone: 01-Jun-26] Start Project											
FRC-1010	Contractors	Clean & Prep Roof for Caulkings & Primer / Remove & Re-Spray Blister Areas	01-Jun-26	03-Jun-26	3	[Gantt bar: 01-Jun-26 to 03-Jun-26] Clean & Prep Roof for Caulkings & Primer / Remove & Re-Spray Blister Areas											
FRC-1020	Contractors	Install Primer & Elastomeric Coating	04-Jun-26	11-Jun-26	6	[Gantt bar: 04-Jun-26 to 11-Jun-26] Install Primer & Elastomeric Coating											
FRC-1030	Contractors	Clean Site	12-Jun-26	12-Jun-26	1	[Gantt bar: 12-Jun-26 to 12-Jun-26] Clean Site											

█ Actual Work    
 █ Critical Remaining Work    
  Summary  
█ Remaining Work    
 ◆ Milestone

Date	Revision	Checked	Approved
02-Mar-26	Baseline - Bid Schedule		











**NOTICE TO BIDDERS**

1. Notice is hereby given that the governing board ("Board") of the Bakersfield City School District ("District") will receive sealed bids for the following project, Bid No. **26247.00-20-DM** ("Project" or "Contract"):

**Stiern Middle School Spray Polyurethane Foam Roofing**

2. The Project consists of:

**Refer to scope of work.**

3. To bid on this Project, the Bidder is required to possess one or more of the following State of California contractors' license(s):

**BP-01 Roofing (C-39)**

The Bidder's license(s) must remain active and in good standing throughout the term of the Contract.

4. To bid on this Project, the Bidder is required to be registered as a public works contractor with the Department of Industrial Relations pursuant to the Labor Code.
5. Contract Documents will be available on or after March 03, 2026, for review at the District Maintenance, Operations, and Facilities Office, and may be downloaded from the District's website, using the following link.

<http://mot.bcsd.com/Construction%20Consultants/Stiern%20SPF%20Roofing%2026247.00-20-DM/>

In addition, Contract Documents are available for bidders' review at the following builders' exchanges:

- A. Kern County Builder's Exchange (661) 324 - 4921
6. Contract Documents are also available for purchase at Blueprint Services, 1100 18<sup>th</sup> Street, Bakersfield, CA 93301.
7. **Sealed bids will be received until 2:00 p.m., March 17, 2026**, at the District Maintenance, Operations, and Facilities Office, 1501 Feliz Drive, Bakersfield, California 93307 at or after which time the bids will be opened and publicly read aloud. Any bid that is submitted after this time shall be nonresponsive and returned to the bidder. Any claim by a bidder of error in its bid must be made in compliance with section 5100 et seq. of the Public Contract Code.
8. This project requires mandatory prequalification pursuant to AB 1565 of all general contractors and all mechanical, electrical, and plumbing subcontractors holding licenses in classifications A, B, C-4, C-7, C-10, C-16, C-20, C-34, C-36, C-38, C-42, C-43 and C-46. Prequalification can be completed using the online prequalification

system at [www.qualitybidders.com](http://www.qualitybidders.com). A bid package will not be accepted from any bidder that is required to submit a completed questionnaire and supporting documents pursuant to AB 1565, but has not done so at least ten (10) business days prior to the date fixed for the public opening of sealed bids or that has not been prequalified for at least five (5) business days prior to that date.

9. All bids shall be on the form provided by the District. Each bid must conform and be responsive to all pertinent Contract Documents, including, but not limited to, the Instructions to Bidders.
10. A bid bond by an admitted surety insurer on the form provided by the District a cashier's check or a certified check, drawn to the order of the Bakersfield City School District, in the amount of ten percent (10%) of the total bid price, shall accompany the Bid Form and Proposal, as a guarantee that the Bidder will, within seven (7) calendar days after the date of the Notice of Award, enter into a contract with the District for the performance of the services as stipulated in the bid.
11. **A non-mandatory job walk and site visit will be held on March 10, 2026, at 9:00 a.m. beginning at Sierra Middle School located at 3017 Center Street, Bakersfield, California. This job walk will then continue to Hort Elementary School, 2301 Park Drive, Stiern Middle School, 2551 Morning Drive, Nichols Elementary School, 3401 Renegade Avenue, and will conclude at Jefferson Elementary School, 816 Lincoln Street. All participants are required to sign in front of the Administration Building.**
12. The successful Bidder shall be required to furnish a 100% Performance Bond and a 100% Payment Bond if it is awarded the Contract for the Work.
13. The successful Bidder may substitute securities for any monies withheld by the District to ensure performance under the Contract, in accordance with the provisions of section 22300 of the Public Contract Code.
14. The successful bidder will be required to certify that it either meets the Disabled Veteran Business Enterprise ("DVBE") goal of three percent (3%) participation or made a good faith effort to solicit DVBE participation in this Contract if it is awarded the Contract for the Work.
15. The Contractor and all Subcontractors under the Contractor shall pay all workers on all Work performed pursuant to this Contract not less than the general prevailing rate of per diem wages and the general prevailing rate for holiday and overtime work as determined by the Director of the Department of Industrial Relations, State of California, for the type of work performed and the locality in which the work is to be performed within the boundaries of the District, pursuant to section 1770 et seq. of the California Labor Code. Prevailing wage rates are also available from the District or on the Internet at: <http://www.dir.ca.gov>.
16. This Project is subject to labor compliance monitoring and enforcement by the Department of Industrial Relations pursuant to Labor Code section 1771.4 and subject to the requirements of Title 8 of the California Code of Regulations. The successful Bidder shall comply with all requirements of Division 2, Part 7, Chapter 1, Articles 1-5 of the Labor Code.

17. The District shall award the Contract, if it awards it at all, to the lowest responsive responsible bidder based on:
  - A. The base bid amount only.
18. The Board reserves the right to reject any and all bids and/or waive any irregularity in any bid received. If the District awards the Contract, the security of unsuccessful bidder(s) shall be returned within sixty (60) days from the time the award is made. Unless otherwise required by law, no bidder may withdraw its bid for ninety (90) days after the date of the bid opening.

END OF DOCUMENT

**INSTRUCTIONS TO BIDDERS**

Bidders shall follow the instructions in this document, and shall submit all documents, forms, and information required for consideration of a bid.

Bakersfield City School District ("District") will evaluate information submitted by the apparent low Bidder and, if incomplete or unsatisfactory to District, Bidder's bid may be rejected at the sole discretion of District.

1. Bids are requested for a general construction contract, or work described in general, for the following project ("Project" or "Contract"):

**Stiern Middle School Spray Polyurethane Foam Roofing Project  
No. 26247.00-20-DM**

To bid on this Project, the Bidder is required to possess one or more of the following State of California contractors' license(s):

**BP 01 Roofing (C-39)**

2. A Bidder and its subcontractors must possess the appropriate State of California contractors' license and must maintain the license throughout the duration of the project. Bidders must also be registered as a public works contractor with the Department of Industrial Relations pursuant to the Labor Code. Bids submitted by a contractor who is not properly licensed or registered shall be deemed nonresponsive and will not be considered.
3. This Project **requires** prequalified pursuant to AB 1565 of all general contractors and all mechanical, electrical and plumbing subcontractors. If required, Prequalification can be completed using the online prequalification system at [www.qualitybidders.com](http://www.qualitybidders.com). A bid package will not be accepted from any bidder that is required to submit a completed questionnaire and supporting documents pursuant to AB 1565, but has not done so at least ten (10) business days prior to the date fixed for the public opening of sealed bids or that has not been prequalified for at least five (5) business days prior to that date.
4. District will receive sealed bids from bidders as stipulated in the Notice to Bidders.
  - a. All bids must be sealed in an envelope, marked with the name and address of the Bidder, name of the Project, the Project Number and/or bid number, and time of bid opening.
  - b. Bids must be submitted to the BCSD – Maintenance, Operations, & Facilities Office at 1501 Feliz Drive, Bakersfield, CA, 93307 by date and time shown in the Notice to Bidders.
  - c. Bids must contain all documents as required herein.
5. Bidders are advised that on the date that bids are opened, telephones will not be available at the District Offices for use by bidders or their representatives.

6. Bids will be opened at or after the time indicated for receipt of bids.
7. Bidders must submit bids on the documents titled Bid Form and Proposal, and must submit all other required District forms. Bids not submitted on the District's required forms shall be deemed nonresponsive and shall not be considered. Additional sheets required to fully respond to requested information are permissible.
8. Bidders shall not modify the Bid Form and Proposal or qualify their bids. Bidders shall not submit to the District a re-formatted, re-typed, altered, modified, or otherwise recreated version of the Bid Form and Proposal or other District-provided document.
9. Bids shall be clearly written and without erasure or deletions. District reserves the right to reject any bid containing erasures, deletions, or illegible contents.
10. Bidders must supply all information required by each Bid Document. Bids must be full and complete. District reserves the right in its sole discretion to reject any bid as nonresponsive as a result of any error or omission in the bid. Bidders must complete and submit all of the following documents with the Bid Form and Proposal:
  - a. Bid Bond on the District's form, or other security.
  - b. Designated Subcontractors List.
  - c. Site Visit Certification, if a site visit was required.
  - d. Non-Collusion Declaration.
  - e. Iran Contracting Act Certification
  - f. Russia Sanctions Compliance Certification
11. Bidders must submit with their bids cash, a cashier's check or a certified check payable to District, or a bid bond by an admitted surety insurer of not less than ten percent (10%) of amount of Base Bid, plus all additive alternates ("Bid Bond"). If Bidder chooses to provide a Bid Bond as security, Bidder must use the required form of corporate surety provided by District. The Surety on Bidder's Bid Bond must be an insurer admitted in the State of California and authorized to issue surety bonds in the State of California. Bids submitted without necessary bid security will be deemed nonresponsive and will not be considered.
12. If Bidder to whom the Contract is awarded fails or neglects to enter into the Contract and submit required bonds, insurance certificates, and all other required documents, within **FOURTEEN (14)** calendar days after the date of the Notice of Award, District may deposit Bid Bond, cash, cashier's check, or certified check for collection, and proceeds thereof may be retained by District as liquidated damages for failure of Bidder to enter into Contract, in the sole discretion of District. It is agreed that calculation of damages District may suffer as a result of Bidder's failure to enter into the Contract would be extremely difficult and impractical to determine and that the amount of the Bidder's required bid security shall be the agreed and conclusively presumed amount of damages.

13. Bidders must submit with the bid the Designated Subcontractors List for those subcontractors who will perform any portion of Work, including labor, rendering of service, or specially fabricating and installing a portion of the Work or improvement according to detailed drawings contained in the plans and specifications, in excess of one half of one percent (0.5%) of total bid. Failure to submit this list when required by law shall result in bid being deemed nonresponsive and the bid will not be considered.
14. All of the listed subcontractors are required to be registered as a public works contractor with the Department of Industrial Relations pursuant to the Labor Code.
  - a. An inadvertent error in listing the California contractor license number on the Designated Subcontractors List shall not be grounds for filing a bid protest or grounds for considering the bid nonresponsive if the correct contractor's license number is submitted to the District within 24 hours after the bid opening and the corrected number corresponds with the submitted name and location for that subcontractor.
  - b. An inadvertent error listing an unregistered subcontractor shall not be grounds for filing a bid protest or grounds for considering the bid nonresponsive provided that any of the following apply:
    - (1) The subcontractor is registered prior to the bid opening.
    - (2) The subcontractor is registered and has paid the penalty registration fee within 24 hours after the bid opening.
    - (3) The subcontractor is replaced by another registered subcontractor pursuant to Public Contract Code section 4107.
15. If a mandatory pre-bid conference and site visit ("Site Visit") is required as referenced in the Notice to Bidders, then Bidders must submit the Site Visit Certification with their Bid. District will transmit to all prospective Bidders of record such Addenda as District in its discretion considers necessary in response to questions arising at the Site Visit. Oral statements shall not be relied upon and will not be binding or legally effective. Addenda issued by the District as a result of the Site Visit, if any, shall constitute the sole and exclusive record and statement of the results of the Site Visit.
16. Bidders shall submit the Non-Collusion Declaration with their bids. Bids submitted without the Non-Collusion Declaration shall be deemed nonresponsive and will not be considered.
17. The Contractor and all Subcontractors under the Contractor shall pay all workers on all work performed pursuant to the Contract not less than the general prevailing rate of per diem wages and the general prevailing rate for holiday and overtime work as determined by the Director of the Department of Industrial Relations, State of California, for the type of work performed and the locality in which the work is to be performed within the boundaries of the District, pursuant to sections 1770 et seq. of the California Labor Code. Copies of the general prevailing rates of per diem wages for each craft, classification, or type of worker needed to execute the Contract, as determined by Director of the Department of Industrial Relations, are available upon

request at the District's principal office. Prevailing wage rates are also available on the internet at <http://www.dir.ca.gov>.

18. Section 17076.11 of the Education Code requires school districts using funds allocated pursuant to the State of California School Facility Program for the construction and/or modernization of school building(s) to have a participation goal for disabled veteran business enterprises ("DVBE") of at least three percent (3%) per year of the overall dollar amount expended on projects that receive state funding or demonstrate its good faith effort to solicit DVBE participation in this Contract. In order to meet this requirement by demonstrating a good faith effort, Bidder must advertise for DVBE-certified subcontractors and suppliers before submitting its Bid. For any project that is at least partially state-funded, the lowest responsive responsible Bidder awarded the Contract must submit certification of compliance with the procedures for implementation of DVBE contracting goals with its signed Agreement. DVBE Certification form is attached. Do not submit this form with your Bid.
19. Submission of bid signifies careful examination of Contract Documents and complete understanding of the nature, extent, and location of Work to be performed. Bidders must complete the tasks listed below as a condition to bidding, and submission of a bid shall constitute the Bidder's express representation to District that Bidder has fully completed the following:
  - a. Bidder has visited the Site, if required, and has examined thoroughly and understood the nature and extent of the Contract Documents, Work, Site, locality, actual conditions, as-built conditions, and all local conditions and federal, state and local laws, and regulations that in any manner may affect cost, progress, performance, or furnishing of Work or that relate to any aspect of the means, methods, techniques, sequences, or procedures of construction to be employed by Bidder and safety precautions and programs incident thereto;
  - b. Bidder has conducted or obtained and has understood all examinations, investigations, explorations, tests, reports, and studies that pertain to the subsurface conditions, as-built conditions, underground facilities, and all other physical conditions at or contiguous to the Site or otherwise that may affect the cost, progress, performance, or furnishing of Work, as Bidder considers necessary for the performance or furnishing of Work at the Contract Sum, within the Contract Time, and in accordance with the other terms and conditions of Contract Documents, including specifically the provisions of the General Conditions; and no additional examinations, investigations, explorations, tests, reports, studies, or similar information or data are or will be required by Bidder for such purposes;
  - c. Bidder has correlated its knowledge and the results of all such observations, examinations, investigations, explorations, tests, reports, and studies with the terms and conditions of the Contract Documents;
  - d. Bidder has given the District prompt written notice of all conflicts, errors, ambiguities, or discrepancies that it has discovered in or among the Contract Documents and the actual conditions, and the written resolution(s) thereof by the District is/are acceptable to Bidder;

- e. Bidder has made a complete disclosure in writing to the District of all facts bearing upon any possible interest, direct or indirect, that Bidder believes any representative of the District or other officer or employee of the District presently has or will have in this Contract or in the performance thereof or in any portion of the profits thereof;
  - f. Bidder must, prior to bidding, perform the work, investigations, research, and analysis required by this document and that Bidder represented in its Bid Form and Proposal and the Agreement that it performed prior to bidding. Contractor under this Contract is charged with all information and knowledge that a reasonable bidder would ascertain from having performed this required work, investigation, research, and analysis. Bid prices must include entire cost of all work "incidental" to completion of the Work.
  - g. Conditions Shown on the Contract Documents: Information as to underground conditions, as-built conditions, or other conditions or obstructions, indicated in the Contract Documents, e.g., on Drawings or in Specifications, has been obtained with reasonable care, and has been recorded in good faith. However, District only warrants, and Bidder may only rely, on the accuracy of limited types of information.
    - (1) As to above-ground conditions or as-built conditions shown or indicated in the Contract Documents, there is no warranty, express or implied, or any representation express or implied, that such information is correctly shown or indicated. This information is verifiable by independent investigation and Bidder is required to make such verification as a condition to bidding. In submitting its Bid, Bidder shall rely on the results of its own independent investigation. In submitting its Bid, Bidder shall not rely on District-supplied information regarding above-ground conditions or as-built conditions.
    - (2) As to any subsurface condition shown or indicated in the Contract Documents, Bidder may rely only upon the general accuracy of actual reported depths, actual reported character of materials, actual reported soil types, actual reported water conditions, or actual obstructions shown or indicated. District is not responsible for the completeness of such information for bidding or construction; nor is District responsible in any way for any conclusions or opinions that the Bidder has drawn from such information; nor is the District responsible for subsurface conditions that are not specifically shown (for example, District is not responsible for soil conditions in areas contiguous to areas where a subsurface condition is shown).
20. Bids shall be based on products and systems specified in Contract Documents or listed by name in Addenda. Whenever in the Specifications any materials, process, or article is indicated or specified by grade, patent, or proprietary name, or by name of manufacturer, that Specification shall be deemed to be followed by the words "or equal." Bidder may, unless otherwise stated, offer any material, process, or article that shall be substantially equal or better in every respect to that so indicated or specified. The District is not responsible and/or liable in any way for a Contractor's damages and/or claims related, in any way, to that Contractor's basing its bid on any requested substitution that the District has not approved in advance and in writing. Contractors and materials suppliers who submit requests for substitutions prior to

the award of the Contract must do so in writing and in compliance with Public Contract Code section 3400. All requests must comply with the following:

- a. District must receive any notice of request for substitution of a specified item a minimum of **TEN (10)** calendar days prior to bid opening. The Successful Bidder will not be allowed to substitute specified items unless properly noticed.
  - b. Within 35 days after the date of the Notice of Award, the Successful Bidder shall submit data substantiating the request(s) for all substitution(s) containing sufficient information to assess acceptability of product or system and impact on Project, including, without limitation, the requirements specified in the Special Conditions and the Specifications. Insufficient information shall be grounds for rejection of substitution.
  - c. Approved substitutions, if any, shall be listed in Addenda. District reserves the right not to act upon submittals of substitutions until after bid opening.
  - d. Substitutions may be requested after Contract has been awarded only if indicated in and in accordance with requirements specified in the Special Conditions and the Specifications.
21. Bidders may examine any available "as-built" drawings of previous work by giving District reasonable advance notice. District will not be responsible for accuracy of "as-built" drawings. The document entitled Existing Conditions applies to all supplied "as-built" drawings.
  22. All questions about the meaning or intent of the Contract Documents are to be directed via email to the District to [zasoskil@bcisd.com](mailto:zasoskil@bcisd.com) and [orozcob@bcisd.com](mailto:orozcob@bcisd.com). Interpretations or clarifications considered necessary by the District in response to such questions will be issued in writing by Addenda and emailed, faxed, mailed, or delivered to all parties recorded by the District as having received the Contract Documents or posted on the District's website at <http://mot.bcisd.com/Construction%20Consultants/Stiern%20SPF%20Roofing%2026247.00-20-DM/>. Questions received less than **SEVEN (7)** calendar days prior to the date for opening bids may not be answered. Only questions answered by formal written Addenda will be binding. Oral and other interpretations or clarifications will be without legal effect.
  23. Addenda may also be issued to modify other parts of the Contract Documents as deemed advisable by the District.
  24. Each Bidder must acknowledge each Addendum in its Bid Form and Proposal by number or its Bid shall be considered non-responsive. Each Addendum shall be part of the Contract Documents. A complete listing of Addenda may be secured from the District.
  25. This Contract may include alternates. Alternates are defined as alternate products, materials, equipment, systems, methods, or major elements of the construction that may, at the District's option and under terms established in the Contract and pursuant to section 20103.8 of the Public Contract Code, be selected for the Work.

26. The District shall award the Contract, if it awards it at all, to the lowest responsive responsible bidder based on the criteria as indicated in the Notice to Bidders. In the event two or more responsible bidders submit identical bids, the District shall select the Bidder to whom to award the Contract by lot.
27. Discrepancies between written words and figures, or words and numerals, will be resolved in favor of figures or numerals.
28. Bidders in contention for contract awards shall be required to attend a Post-Bid interview, which will be set within three (3) calendar days following bid opening. A duly authorized representative of the apparent low bidder is required to attend the Post Bid Interview, in person. The apparent low bidder's authorized representative(s) must have (1) knowledge of how the bid submitted was prepared, (2) the person responsible for supervising performance of the Work, and (3) the authority to bind the apparent low bidder. Failure to attend the Post Bid Interview as scheduled will be considered just cause for the District to reject the Bid as nonresponsive.
29. Any bid protest by any Bidder regarding any other bid must be submitted in writing to the District, before 5:00 p.m. of the **THIRD (3rd)** business day following bid opening.
  - a. Only a Bidder who has actually submitted a bid, and who could be awarded the Contract if the bid protest is upheld, is eligible to submit a bid protest. Subcontractors are not eligible to submit bid protests. A Bidder may not rely on the bid protest submitted by another Bidder.
  - b. A bid protest must contain a complete statement of any and all bases for the protest and all supporting documentation. Materials submitted after the bid protest deadline will not be considered.
  - c. The protest must refer to the specific portions of all documents that form the basis for the protest.
    - (1) Without limitation to any other basis for protest, an inadvertent error in listing the California contractor's license number on the Designated Subcontractors List shall not be grounds for filing a bid protest or grounds for considering the bid nonresponsive if the correct contractor's license number is submitted to the District within 24 hours after the bid opening and the corrected number corresponds with the submitted name and location for that subcontractor.
    - (2) Without limitation to any other basis for protest, an inadvertent error listing an unregistered subcontractor shall not be grounds for filing a bid protest or grounds for considering the bid nonresponsive provided that any of the following apply:
      - (i) The subcontractor is registered prior to the bid opening.
      - (ii) The subcontractor is registered and has paid the penalty registration fee within 24 hours after the bid opening.

- (iii) The subcontractor is replaced by another registered subcontractor pursuant to Public Contract Code section 4107.
  - d. The protest must include the name, address and telephone number of the person representing the protesting party.
  - e. The party filing the protest must concurrently transmit a copy of the protest and any attached documentation to all other parties with a direct financial interest that may be adversely affected by the outcome of the protest. Such parties shall include all other bidders or proposers who appear to have a reasonable prospect of receiving an award depending upon the outcome of the protest.
  - f. The procedure and time limits set forth in this paragraph are mandatory and are each bidder's sole and exclusive remedy in the event of bid protest. Failure to comply with these procedures shall constitute a waiver of any right to further pursue the bid protest, including filing a Government Code Claim or legal proceedings.
- 30. The Bidder to whom Contract is awarded shall execute and submit the following documents by 5:00 p.m. of the **FOURTEEN (14th)** calendar day following the date of the Notice of Award. Failure to properly and timely submit these documents entitles District to reject the bid as nonresponsive.
  - a. Agreement: To be executed by successful Bidder. Submit four (2) copies, each bearing an original signature.
  - b. Performance Bond (100%): On the form provided in the Contract Documents and fully executed as indicated on the form.
  - c. Payment Bond (Contractor's Labor and Material Bond) (100%): On the form provided in the Contract Documents and fully executed as indicated on the form.
  - d. Insurance Certificates and Endorsements as required.
  - e. Workers' Compensation Certification.
  - f. Prevailing Wage and Related Labor Requirements Certification.
  - g. Disabled Veteran Business Enterprise Participation Certification.
  - h. Drug-Free Workplace Certification.
  - i. Tobacco-Free Environment Certification.
  - j. Drug and Alcohol-Free Schools Certification
  - k. Lead-Based Materials Certification.
  - l. Criminal Background Investigation/Fingerprinting Certification.

- m. DIR Registration Verification: Must include Department of Industrial Relations (DIR) registration number of each subcontractor for all tiers.
31. Time for Completion: District may issue a Notice to Proceed within **NINETY (90)** days from the date of the Notice of Award. Once Contractor has received the Notice to Proceed, Contractor shall complete the Work within the period of time indicated in the Contract Documents.
- a. In the event that the District desires to postpone issuing the Notice to Proceed beyond this 90-day period, it is expressly understood that with reasonable notice to the Contractor, the District may postpone issuing the Notice to Proceed.
  - b. It is further expressly understood by Contractor that Contractor shall not be entitled to any claim of additional compensation as a result of the postponement of the issuance of the Notice to Proceed beyond a 90-day period. If the Contractor believes that a postponement of issuance of the Notice to Proceed will cause a hardship to the Contractor, the Contractor may terminate the Contract. Contractor's termination due to a postponement beyond this 90-day period shall be by written notice to District within **TEN (10)** calendar days after receipt by Contractor of District's notice of postponement.
  - c. It is further understood by the Contractor that in the event that Contractor terminates the Contract as a result of postponement by the District, the District shall only be obligated to pay Contractor for the Work that Contractor had performed at the time of notification of postponement and which the District had in writing authorized Contractor to perform prior to issuing a Notice to Proceed.
  - d. Should the Contractor terminate the Contract as a result of a notice of postponement, District shall have the authority to award the Contract to the next lowest responsive responsible bidder.
32. District reserves the right to reject any or all bids, including without limitation the right to reject any or all nonconforming, nonresponsive, unbalanced, or conditional bids, to re-bid, and to reject the bid of any bidder if District believes that it would not be in the best interest of the District to make an award to that bidder, whether because the bid is not responsive or the bidder is unqualified or of doubtful financial ability or fails to meet any other pertinent standard or criteria established by District. District also reserves the right to waive any inconsequential deviations or irregularities in any bid. For purposes of this paragraph, an "unbalanced bid" is one having nominal prices for some work items and/or enhanced prices for other work items.
33. It is the policy of the District that no qualified person shall be excluded from participating in, be denied the benefits of, or otherwise be subjected to discrimination in any consideration leading to the award of contract, based on race, color, gender, sexual orientation, political affiliation, age, ancestry, religion, marital status, national origin, medical condition or disability. The Successful Bidder and its subcontractors shall comply with applicable federal and state laws, including, but not limited to the California Fair Employment and Housing Act, beginning with Government Code section 12900, and Labor Code section 1735.

34. Prior to the award of Contract, District reserves the right to consider the responsibility of the Bidder. District may conduct investigations as District deems necessary to assist in the evaluation of any bid and to establish the responsibility, including, without limitation, qualifications and financial ability of Bidders, proposed subcontractors, suppliers, and other persons and organizations to perform and furnish the Work in accordance with the Contract Documents to District's satisfaction within the prescribed time.

END OF DOCUMENT

**BID FORM AND PROPOSAL**

To: Governing Board of the Bakersfield City School District ("District" or "Owner")

From: \_\_\_\_\_  
(Proper Name of Bidder)

Bid Package: \_\_\_\_\_

The undersigned declares that Bidder has read and understands the Contract Documents, including, without limitation, the Notice to Bidders and the Instructions to Bidders, and agrees and proposes to furnish all necessary labor, materials, and equipment to perform and furnish all work in accordance with the terms and conditions of the Contract Documents, including, without limitation, the Drawings and Specifications of Bid No. **26247.00-20-DM**, for the following project known as:

**Stiern Middle School Spray Polyurethane Foam Roofing**

("Project" or "Contract") and will accept in full payment for that Work the following total lump sum amount, all taxes included:

<p>_____ dollars      \$ _____</p> <p><b><i>BASE BID</i></b></p>
--

**Additive/Deductive Alternates: None**

**Additional Detail Regarding Calculation of Base Bid**

1. The undersigned has reviewed the Work outlined in the Contract Documents and fully understands the scope of Work required in this Proposal, understands the construction and project management function(s) is described in the Contract Documents, and that each Bidder who is awarded a contract shall be in fact a prime contractor, not a subcontractor, to the District, and agrees that its Proposal, if accepted by the District, will be the basis for the Bidder to enter into a contract with the District in accordance with the intent of the Contract Documents.
2. The undersigned has notified the District in writing of any discrepancies or omissions or of any doubt, questions, or ambiguities about the meaning of any of the Contract Documents, and has contacted the Construction Manager before bid date to verify the issuance of any clarifying Addenda.
3. The undersigned agrees to commence work under this Contract on the date established in the Contract Documents and to complete all work within the time specified in the Contract Documents.
4. The liquidated damages clause of the General Conditions and Agreement is hereby acknowledged.

5. It is understood that the District reserves the right to reject this bid and that the bid shall remain open to acceptance and is irrevocable for a period of ninety (90) days.
6. The following documents are attached hereto:
  - Bid Bond on the District's form or other security
  - Designated Subcontractors List
  - ~~Site Visit Certification~~
  - Non-Collusion Declaration
  - Iran Contracting Act Certification
  - Russia Sanctions Compliance Certification

7. Receipt and acceptance of the following Addenda is hereby acknowledged:

No. _____, Dated _____	No. _____, Dated _____
No. _____, Dated _____	No. _____, Dated _____
No. _____, Dated _____	No. _____, Dated _____

8. Bidder acknowledges that the license required for performance of the Work is a \_\_\_\_\_ license.
9. Bidder hereby certifies that Bidder is able to furnish labor that can work in harmony with all other elements of labor employed or to be employed on the Work.
10. Bidder specifically acknowledges and understands that if it is awarded the Contract, that it shall perform the Work of the Project while complying with all requirements of the Department of Industrial Relations.
11. Bidder hereby certifies that its bid includes sufficient funds to permit Bidder to comply with all local, state or federal labor laws or regulations during the Project, including payment of prevailing wage, and that Bidder will comply with the provisions of Labor Code section 2810(d) if awarded the Contract
12. Bidder represents that it is competent, knowledgeable, and has special skills with respect to the nature, extent, and inherent conditions of the Work to be performed. Bidder further acknowledges that there are certain peculiar and inherent conditions existent in the construction of the Work that may create, during the Work, unusual or peculiar unsafe conditions hazardous to persons and property.
13. Bidder expressly acknowledges that it is aware of such peculiar risks and that it has the skill and experience to foresee and to adopt protective measures to adequately and safely perform the Work with respect to such hazards.
14. Bidder expressly acknowledges that it is aware that if a false claim is knowingly submitted (as the terms "claim" and "knowingly" are defined in the California False Claims Act, Gov. Code, § 12650 et seq.), the District will be entitled to civil remedies

set forth in the California False Claim Act. It may also be considered fraud and the Contractor may be subject to criminal prosecution.

15. The undersigned Bidder certifies that it is, at the time of bidding, and shall be throughout the period of the Contract, licensed by the State of California to do the type of work required under the terms of the Contract Documents and registered as a public works contractor with the Department of Industrial Relations. Bidder further certifies that it is regularly engaged in the general class and type of work called for in the Contract Documents.

Furthermore, Bidder hereby certifies to the District that all representations, certifications, and statements made by Bidder, as set forth in this bid form, are true and correct and are made under penalty of perjury.

Dated this \_\_\_\_\_ day of \_\_\_\_\_ 20 \_\_\_\_

Name of Bidder: \_\_\_\_\_

Type of Organization: \_\_\_\_\_

Signature: \_\_\_\_\_

Print Name: \_\_\_\_\_

Title: \_\_\_\_\_

Address of Bidder: \_\_\_\_\_

Taxpayer Identification No. of Bidder: \_\_\_\_\_

Telephone Number: \_\_\_\_\_

Fax Number: \_\_\_\_\_

E-mail: \_\_\_\_\_ Web Page: \_\_\_\_\_

Contractor's License No(s): No.: \_\_\_\_\_ Class: \_\_\_\_\_ Expiration Date: \_\_\_\_\_

No.: \_\_\_\_\_ Class: \_\_\_\_\_ Expiration Date: \_\_\_\_\_

No.: \_\_\_\_\_ Class: \_\_\_\_\_ Expiration Date: \_\_\_\_\_

Public Works Contractor Registration No.: \_\_\_\_\_

END OF DOCUMENT

**BID BOND**

**(Note: If Bidder is providing a bid bond as its bid security, Bidder must use this form, NOT a surety company form.)**

KNOW ALL PERSONS BY THESE PRESENTS:

That the undersigned, \_\_\_\_\_, as Principal ("Principal"),  
and \_\_\_\_\_, as  
Surety ("Surety"), a corporation organized and existing under and by virtue of the laws of  
the State of California and authorized to do business as a surety in the State of California,  
are held and firmly bound unto the Bakersfield City School District ("District") of Kern  
County, State of California, as Obligee, in an amount equal to ten percent (10%) of the  
Base Bid plus alternates, in the sum of

\_\_\_\_\_ Dollars (\$ \_\_\_\_\_)

lawful money of the United States of America, for the payment of which sum well and truly  
to be made, we, and each of us, bind ourselves, our heirs, executors, administrators,  
successors, and assigns, jointly and severally, firmly by these presents.

THE CONDITION OF THIS OBLIGATION IS SUCH that whereas the Principal has submitted a  
bid to the District for all Work specifically described in the accompanying bid for the  
following project: **Stiern Middle School Spray Polyurethane Foam Roofing Project No.  
26247.00-20-DM** ("Project" or "Contract").

NOW, THEREFORE, if the Principal is awarded the Contract and, within the time and manner  
required under the Contract Documents, after the prescribed forms are presented to  
Principal for signature, enters into a written contract, in the prescribed form in accordance  
with the bid, and files two bonds, one guaranteeing faithful performance and the other  
guaranteeing payment for labor and materials as required by law, and meets all other  
conditions to the Contract between the Principal and the Obligee becoming effective, or if  
the Principal shall fully reimburse and save harmless the Obligee from any damage  
sustained by the Obligee through failure of the Principal to enter into the written contract  
and to file the required performance and labor and material bonds, and to meet all other  
conditions to the Contract between the Principal and the Obligee becoming effective, then  
this obligation shall be null and void; otherwise, it shall be and remain in full force and  
effect. The full payment of the sum stated above shall be due immediately if Principal fails  
to execute the Contract within fourteen (14) days of the date of the District's Notice of  
Award to Principal.

Surety, for value received, hereby stipulates and agrees that no change, extension of time,  
alteration or addition to the terms of the Contract or the call for bids, or to the work to be  
performed thereunder, or the specifications accompanying the same, shall in any way affect  
its obligation under this bond, and it does hereby waive notice of any such change,  
extension of time, alteration or addition to the terms of the Contract or the call for bids, or  
to the work, or to the specifications.

In the event suit is brought upon this bond by the Obligee and judgment is recovered, the Surety shall pay all costs incurred by the Obligee in such suit, including a reasonable attorneys' fee to be fixed by the Court.

If the District awards the bid, the security of unsuccessful bidder(s) shall be returned within sixty (60) days from the time the award is made. Unless otherwise required by law, no bidder may withdraw its bid for ninety (90) days after the date of the bid opening.

IN WITNESS WHEREOF, this instrument has been duly executed by the Principal and Surety above named, on the \_\_\_\_\_ day of \_\_\_\_\_, 20\_\_.

\_\_\_\_\_  
Principal

\_\_\_\_\_  
By

\_\_\_\_\_  
Surety

\_\_\_\_\_  
By

\_\_\_\_\_  
Name of California Agent of Surety

\_\_\_\_\_  
Address of California Agent of Surety

\_\_\_\_\_  
Telephone Number of California Agent of Surety

**Bidder must attach Power of Attorney and Certificate of Authority for Surety and a Notarial Acknowledgment for all Surety's signatures. The California Department of Insurance must authorize the Surety to be an admitted Surety Insurer.**

END OF DOCUMENT

**DESIGNATED SUBCONTRACTORS LIST**  
**(Public Contact Code Sections 4100-4114)**

PROJECT: **Stiern Middle School Spray Polyurethane Foam Roofing Project No. 26247.00-20-DM**

Bidder acknowledges and agrees that it must clearly set forth below the name, location and California contractor license number of each subcontractor who will perform work or labor or render service to the Bidder in or about the construction of the Work or who will specially fabricate and install a portion of the Work according to detailed drawings contained in the plans and specifications in an amount in excess of one-half of one percent (0.5%) of Bidder's total Base Bid and the kind of Work that each will perform. Vendors or suppliers of materials only do not need to be listed.

Bidder acknowledges and agrees that, if Bidder fails to list as to any portion of Work, or if Bidder lists more than one subcontractor to perform the same portion of Work, Bidder must perform that portion itself or be subjected to penalty under applicable law. In case more than one subcontractor is named for the same kind of Work, state the portion of the kind of Work that each subcontractor will perform.

If alternate bid(s) is/are called for and Bidder intends to use subcontractors different from or in addition to those subcontractors listed for work under the Base Bid, Bidder must list subcontractors that will perform Work in an amount in excess of one half of one percent (0.5%) of Bidder's total Base Bid plus alternate(s).

If further space is required for the list of proposed subcontractors, attach additional copies of page 2 showing the required information, as indicated below.

**Subcontractor Name:** \_\_\_\_\_

CA Cont. Lic. #: \_\_\_\_\_ Location: \_\_\_\_\_

DIR Registration #: \_\_\_\_\_

Portion of Work: \_\_\_\_\_

**Subcontractor Name:** \_\_\_\_\_

CA Cont. Lic. #: \_\_\_\_\_ Location: \_\_\_\_\_

DIR Registration #: \_\_\_\_\_

Portion of Work: \_\_\_\_\_

**Subcontractor Name:** \_\_\_\_\_

CA Cont. Lic. #: \_\_\_\_\_ Location: \_\_\_\_\_

DIR Registration #: \_\_\_\_\_

Portion of Work: \_\_\_\_\_

**Subcontractor Name:** \_\_\_\_\_

CA Cont. Lic. #: \_\_\_\_\_ Location: \_\_\_\_\_

DIR Registration #: \_\_\_\_\_

Portion of Work: \_\_\_\_\_

**Subcontractor Name:** \_\_\_\_\_

CA Cont. Lic. #: \_\_\_\_\_ Location: \_\_\_\_\_

DIR Registration #: \_\_\_\_\_

Portion of Work: \_\_\_\_\_

**Subcontractor Name:** \_\_\_\_\_

CA Cont. Lic. #: \_\_\_\_\_ Location: \_\_\_\_\_

DIR Registration #: \_\_\_\_\_

Portion of Work: \_\_\_\_\_

**Subcontractor Name:** \_\_\_\_\_

CA Cont. Lic. #: \_\_\_\_\_ Location: \_\_\_\_\_

DIR Registration #: \_\_\_\_\_

Portion of Work: \_\_\_\_\_

**Subcontractor Name:** \_\_\_\_\_

CA Cont. Lic. #: \_\_\_\_\_ Location: \_\_\_\_\_

DIR Registration #: \_\_\_\_\_

Portion of Work: \_\_\_\_\_

Date: \_\_\_\_\_

Proper Name of Bidder: \_\_\_\_\_

Signature: \_\_\_\_\_

Print Name: \_\_\_\_\_

Title: \_\_\_\_\_

END OF DOCUMENT

**NON-COLLUSION DECLARATION  
(Public Contract Code Section 7106)**

The undersigned declares:

I am the \_\_\_\_\_ of \_\_\_\_\_, the party making the foregoing bid.  
[Title] [Name of Firm]

The bid is not made in the interest of, or on behalf of, any undisclosed person, partnership, company, association, organization, or corporation. The bid is genuine and not collusive or sham. The bidder has not directly or indirectly induced or solicited any other bidder to put in a false or sham bid. The bidder has not directly or indirectly colluded, conspired, connived, or agreed with any bidder or anyone else to put in a sham bid, or to refrain from bidding. The bidder has not in any manner, directly or indirectly, sought by agreement, communication, or conference with anyone to fix the bid price of the bidder or any other bidder, or to fix any overhead, profit, or cost element of the bid price, or of that of any other bidder. All statements contained in the bid are true. The bidder has not, directly or indirectly, submitted his or her bid price or any breakdown thereof, or the contents thereof, or divulged information or data relative thereto, to any corporation, partnership, company, association, organization, bid depository, or to any member or agent thereof, to effectuate a collusive or sham bid, and has not paid, and will not pay, any person or entity for such purpose.

Any person executing this declaration on behalf of a bidder that is a corporation, partnership, joint venture, limited liability company, limited liability partnership, or any other entity, hereby represents that he or she has full power to execute, and does execute, this declaration on behalf of the bidder.

I declare under penalty of perjury under the laws of the State of California that the foregoing is true and correct and that this declaration is executed on \_\_\_\_\_,  
[Date]

at \_\_\_\_\_, \_\_\_\_\_.  
[City] [State]

Date: \_\_\_\_\_

Proper Name of Bidder: \_\_\_\_\_

Signature: \_\_\_\_\_

Print Name: \_\_\_\_\_

Title: \_\_\_\_\_

END OF DOCUMENT

**IRAN CONTRACTING ACT CERTIFICATION**  
**(Public Contract Code Sections 2202-2208)**

PROJECT/CONTRACT NO.: **Stiern Middle School Spray Polyurethane Foam Roofing Project No. 26247.00-20-DM** between the Bakersfield City School District ("District") and \_\_\_\_\_ ("Contractor" or "Bidder")  
("Contract" or "Project").

Prior to bidding on or submitting a proposal for a contract for goods or services of \$1,000,000 or more, the bidder/proposer must submit this certification pursuant to Public Contract Code section 2204.

The bidder/proposer must complete **ONLY ONE** of the following two options. To complete OPTION 1, check the corresponding box **and** complete the certification below. To complete OPTION 2, check the corresponding box, complete the certification below, and attach documentation demonstrating the exemption approval.

- OPTION 1.** Bidder/Proposer is not on the current list of persons engaged in investment activities in Iran created by the California Department of General Services ("DGS") pursuant to Public Contract Code section 2203(b), and we are not a financial institution extending twenty million dollars (\$20,000,000) or more in credit to another person, for forty-five (45) days or more, if that other person will use the credit to provide goods or services in the energy sector in Iran and is identified on the current list of persons engaged in investment activities in Iran created by DGS.
- OPTION 2.** Bidder/Proposer has received a written exemption from the certification requirement pursuant to Public Contract Code sections 2203(c) and (d). *A copy of the written documentation demonstrating the exemption approval is included with our bid/proposal.*

**CERTIFICATION:**

I, the official named below, CERTIFY UNDER PENALTY OF PERJURY that I am duly authorized to legally bind the bidder/proposer to the OPTION selected above. This certification is made under the laws of the State of California.

<i>Vendor Name/Financial Institution (Printed)</i>	<i>Federal ID Number (or n/a)</i>
<i>By (Authorized Signature)</i>	
<i>Printed Name and Title of Person Signing</i>	<i>Date Executed</i>

END OF DOCUMENT

**RUSSIA SANCTIONS COMPLIANCE CERTIFICATION**

PROJECT/CONTRACT NO.: **Stiern Middle School Spray Polyurethane Foam Roofing Project No. 26247.00-20-DM** between the Bakersfield City School District ("District") and \_\_\_\_\_ ("Contractor" or "Bidder")

On March 4, 2022, the Governor of California issued Executive Order N-6-22, regarding U.S. economic sanctions against Russia and Russian entities and individuals. As verification of its compliance with the Executive Order N-6-22, as well as applicable federal and state law, Contractor hereby certifies the following with respect to all economic sanctions imposed by the U.S. government in response to Russia's actions in Ukraine, as well as any sanctions imposed under state law (collectively, "economic sanctions"):

- 1. Contractor is not the target of economic sanctions.
  - 2. Contractor is in compliance with all economic sanctions.
- (Check if applicable – Bid is \$5 million or more) Pursuant to Executive Order N-6-22, if the Contract(s) value is/are \$5 million or more, then Contractor hereby agrees to formally report to the District regarding:
- A. Contractor's compliance with the relevant economic sanctions.
  - B. Steps Contractor has taken in response to Russia's actions in Ukraine, including, but not limited to, desisting from making new investments in, or engaging in financial transactions with, Russian entities, not transferring technology to Russia or Russian entities, and directly providing support to the government and people of Ukraine.

Contractor acknowledges and accepts that failure to complete one of the reporting requirements described above, or determination by the District, at its sole discretion, that Contractor is a target of relevant economic sanctions or is conducting prohibited transactions with sanctioned individuals or entities, may be grounds for termination of the Contract.

**Certification:**

I, the authorized representative for \_\_\_\_\_, certify that I am duly authorized to execute this certification, and the Contractor identified below has conducted a good faith review of existing contracts. I further certify and attest that the Contractor is not a target of economic sanctions, and that the Contractor is in compliance with the economic sanctions imposed by the U.S. government in response to Russia's actions in Ukraine, as well as any requirements related to the Russian sanctions imposed by Executive Order N-6-22 and under state law, if any.

Date: \_\_\_\_\_

Proper Name of Contractor: \_\_\_\_\_

Signature: \_\_\_\_\_

Print Name: \_\_\_\_\_

Title: \_\_\_\_\_

END OF DOCUMENT

**WORKERS' COMPENSATION CERTIFICATION**

PROJECT/CONTRACT NO.: **Stiern Middle School Spray Polyurethane Foam Roofing Project No. 26247.00-20-DM** between the Bakersfield City School District ("District") and \_\_\_\_\_ ("Contractor" or "Bidder") ("Contract" or "Project").

Labor Code section 3700, in relevant part, provides:

Every employer except the State shall secure the payment of compensation in one or more of the following ways:

- a. By being insured against liability to pay compensation by one or more insurers duly authorized to write compensation insurance in this state; and/or
- b. By securing from the Director of Industrial Relations a certificate of consent to self-insure, which may be given upon furnishing proof satisfactory to the Director of Industrial Relations of ability to self-insure and to pay any compensation that may become due to his employees.

I am aware of the provisions of section 3700 of the Labor Code which require every employer to be insured against liability for workers' compensation or to undertake self-insurance in accordance with the provisions of that code, and I will comply with such provisions before commencing the performance of the Work of this Contract.

Date: \_\_\_\_\_

Proper Name of Contractor: \_\_\_\_\_

Signature: \_\_\_\_\_

Print Name: \_\_\_\_\_

Title: \_\_\_\_\_

(In accordance with Labor Code sections 1860 and 1861, the above certificate must be signed and filed with the awarding body prior to performing any Work under this Contract.)

END OF DOCUMENT

**PREVAILING WAGE AND  
RELATED LABOR REQUIREMENTS CERTIFICATION**

PROJECT/CONTRACT NO.: **Stiern Middle School Spray Polyurethane Foam Roofing  
Project No. 26247.00-20-DM** between the Bakersfield City School District ("District") and \_\_\_\_\_ ("Contractor" or "Bidder")  
("Contract" or "Project").

I hereby certify that I will conform to the State of California Public Works Contract requirements regarding prevailing wages, benefits, on-site audits with 48-hours' notice, payroll records, and apprentice and trainee employment requirements, for all Work on the above Project including, without limitation, labor compliance monitoring and enforcement by the Department of Industrial Relations.

Date: \_\_\_\_\_  
Proper Name of Contractor: \_\_\_\_\_  
Signature: \_\_\_\_\_  
Print Name: \_\_\_\_\_  
Title: \_\_\_\_\_

END OF DOCUMENT

**DISABLED VETERAN BUSINESS  
ENTERPRISE PARTICIPATION CERTIFICATION**

PROJECT/CONTRACT NO.: **Stiern Middle School Spray Polyurethane Foam Roofing  
Project No. 26247.00-20-DM** between the Bakersfield City School District ("District") and \_\_\_\_\_ ("Contractor" or "Bidder")  
\_\_\_\_\_  
("Contract" or "Project").

**GENERAL INSTRUCTIONS**

Section 17076.11 of the Education Code requires school districts using, or planning to use, funds allocated pursuant to the State of California School Facility Program ("Program") for the construction and/or modernization of school buildings to have a participation goal for disabled veteran business enterprises ("DVBE") of at least three percent (3%) per year of the overall dollar amount expended each year by the school district on projects that receive state funding. Therefore, the lowest responsive responsible Bidder awarded the Contract must submit this document to the District with its executed Agreement, identifying the steps contractor took to solicit DVBE participation in conjunction with this Contract. **Do not submit this form with your bids.**

**PART I – Method of Compliance with DVBE Participation Goals.** Check the appropriate box to indicate your method of committing the contract dollar amount.

<b>YOUR BUSINESS ENTERPRISE IS:</b>	<b>AND YOU WILL</b>	<b>AND YOU WILL</b>
<b>A.</b> <input type="checkbox"/> Disabled veteran owned and your forces will perform at least 3% of this Contract	Include a copy of your DVBE letter from Office of Small Business and Disabled Veterans Business Enterprise Services ("OSDS")*	Complete Part 1 of this form and the Certification
<b>B.</b> <input type="checkbox"/> Disabled veteran owned but is unable to perform 3% of this Contract with your forces	Use DVBE subcontractors /suppliers to bring the Contract participation to at least 3%	Include a copy of each DVBE's letter from OSDS (including yours, if applicable), and complete Part 1 of this form and the Certification
<b>C.</b> <input type="checkbox"/> <b>NOT</b> disabled veteran owned	Use DVBE subcontractors /suppliers for at least 3% of this Contract	
<b>D.</b> <input type="checkbox"/> Unable to meet the required participation goals after good faith efforts	Make good faith efforts, including contacts, advertisement and DVBE solicitation	Complete all of this form and the Certification

\* A DVBE letter from OSDS is obtained from the participating DVBE.

**You must complete the following table to show the dollar amount of DVBE participation:**

	<b>TOTAL CONTRACT PRICE</b>
<b>A.</b> Prime Bidder, if DVBE (own participation)	\$
<b>B.</b> DVBE Subcontractor or Supplier	
<b>1.</b>	
<b>2.</b>	
<b>3.</b>	
<b>4.</b>	
<b>C.</b> Subtotal (A & B)	
<b>D.</b> Non-DVBE	
<b>E.</b> Total Bid	

**PART II – Contacts.** To identify DVBE subcontractors/suppliers for participation in your contract, you must contact each of the following categories. You should contact several DVBE organizations.

<b>CATEGORY</b>	<b>TELEPHONE NUMBER</b>	<b>DATE CONTACTED</b>	<b>PERSON CONTACTED</b>
<b>1.</b> The District, if any			*
<b>2.</b> OSDS, provides assistance locating DVBEs at <a href="https://caleprocure.ca.gov/pages/PublicSearch/supplier-search.aspx">https://caleprocure.ca.gov/pages/PublicSearch/supplier-search.aspx</a>	(916) 375-4940		*
<b>3.</b> DVBE Organization (List)			*

\*Write "recorded message" in this column, if applicable.

**PART III – Advertisement.** You must advertise for DVBE participation in both a trade and focus paper. List the advertisement you place to solicit DVBE participation. Advertisements should be published at least fourteen (14) days prior to bid/proposal opening; if you cannot advertise fourteen (14) days prior, advertisements should be published as soon as possible. Advertisements must include that your firm is seeking DVBE participation, the project name and location, and your firm’s name, your contact person, and telephone number. Attach copies of advertisements to this form.

FOCUS/TRADE PAPER NAME	CHECK ONE		DATE OF ADVERTISEMENT
	TRADE	FOCUS	

**PART IV – DVBE Solicitations.** List DVBE subcontractors/suppliers that were invited to bid. Use the following instructions to complete the remainder of this section (read the three columns as a sentence from left to right). If you need additional space to list DVBE solicitations, please use a separate page and attach to this form.

IF THE DVBE.....	THEN.....	AND.....		
was selected to participate	Check "YES" in the "SELECTED" column	include a copy of their DVBE letter(s) from OSDS		
was <b>NOT</b> selected to participate	Check "NO" in the "SELECTED" column	state why in the "REASON NOT SELECTED" column		
did not respond to your solicitation	Check the "NO RESPONSE" column.			
DVBE CONTACTED	SELECTED		REASON NOT SELECTED	NO RESPONSE
	YES	NO		

A copy of this form must be retained by you and may be subject to a future audit.

**CERTIFICATION**

I, \_\_\_\_\_, certify that I am the bidder's \_\_\_\_\_ and that I have made a diligent effort to ascertain the facts with regard to the representations made herein. In making this certification, I am aware of section 12650 et seq. of the Government Code providing for the imposition of treble damages for making false claims.

Date: \_\_\_\_\_

Proper Name of Contractor: \_\_\_\_\_

Signature: \_\_\_\_\_

Print Name: \_\_\_\_\_

Title: \_\_\_\_\_

END OF DOCUMENT

**DRUG-FREE WORKPLACE CERTIFICATION**

PROJECT/CONTRACT NO.: **Stiern Middle School Spray Polyurethane Foam Roofing Project No. 26247.00-20-DM** between the Bakersfield City School District ("District") and \_\_\_\_\_ ("Contractor" or "Bidder") ("Contract" or "Project").

This Drug-Free Workplace Certification form is required from the successful Bidder pursuant to Government Code section 8350 et seq., the Drug-Free Workplace Act of 1990. The Drug-Free Workplace Act of 1990 requires that every person or organization awarded a contract or grant for the procurement of any property or service from any state agency must certify that it will provide a drug-free workplace by doing certain specified acts. In addition, the Act provides that each contract or grant awarded by a state agency may be subject to suspension of payments or termination of the contract or grant, and the contractor or grantee may be subject to debarment from future contracting, if the contracting agency determines that specified acts have occurred.

The District is not a "state agency" as defined in the applicable section(s) of the Government Code, but the District is a local agency and public school district under California law and requires all contractors on District projects to comply with the provisions and requirements of the Drug-Free Workplace Act of 1990.

Contractor must also comply with the provisions of Health & Safety Code section 11362.3 which prohibits the consumption or possession of cannabis or cannabis products in any public place, including school grounds, and specifically on school grounds while children are present.

Contractor shall certify that it will provide a drug-free workplace by doing all of the following:

- a. Publishing a statement notifying employees that the unlawful manufacture, distribution, dispensation, possession, or use of a controlled substance is prohibited in the person's or organization's workplace and specifying actions which will be taken against employees for violations of the prohibition.
- b. Establishing a drug-free awareness program to inform employees about all of the following:
  - (1) The dangers of drug abuse in the workplace.
  - (2) The person's or organization's policy of maintaining a drug-free workplace.
  - (3) The availability of drug counseling, rehabilitation, and employee-assistance programs.
  - (4) The penalties that may be imposed upon employees for drug abuse violations.

- c. Requiring that each employee engaged in the performance of the contract or grant be given a copy of the statement required above, and that, as a condition of employment on the contract or grant, the employee agrees to abide by the terms of the statement.

I, the undersigned, agree to fulfill the terms and requirements of Government Code section 8355 listed above and will publish a statement notifying employees concerning (a) the prohibition of controlled substance at the workplace, (b) establishing a drug-free awareness program, and (c) requiring that each employee engaged in the performance of the Contract be given a copy of the statement required by section 8355(a), and requiring that the employee agree to abide by the terms of that statement.

I also understand that if the District determines that I have either (a) made a false certification herein, or (b) violated this certification by failing to carry out the requirements of section 8355, that the Contract awarded herein is subject to termination, suspension of payments, or both. I further understand that, should I violate the terms of the Drug-Free Workplace Act of 1990, I may be subject to debarment in accordance with the requirements of the aforementioned Act.

I acknowledge that I am aware of the provisions of and hereby certify that I will adhere to the requirements of the Drug-Free Workplace Act of 1990 and Health and Safety Code section 11362.3.

Date: \_\_\_\_\_  
Proper Name of Contractor: \_\_\_\_\_  
Signature: \_\_\_\_\_  
Print Name: \_\_\_\_\_  
Title: \_\_\_\_\_

END OF DOCUMENT

**TOBACCO-FREE ENVIRONMENT CERTIFICATION**

PROJECT/CONTRACT NO.: **Stiern Middle School Spray Polyurethane Foam Roofing Project No. 26247.00-20-DM** between the Bakersfield City School District ("District") and \_\_\_\_\_ ("Contractor" or "Bidder") ("Contract" or "Project").

This Tobacco-Free Environment Certification form is required from the successful Bidder.

Pursuant to, without limitation, 20 U.S.C. section 6083, Labor Code section 6400 et seq., Health & Safety Code section 104350 et seq., Business and Professions Code section 22950 et seq., and District Board policies, all District sites, including the Project site, are tobacco-free environments. Smoking and the use of tobacco products by all persons is prohibited on or in District property. District property includes school buildings, school grounds, school-owned vehicles and vehicles owned by others while on District property. The prohibition on smoking includes the use of any electronic smoking device that creates an aerosol or vapor, in any manner or in any form, and the use of any oral smoking device for the purpose of circumventing the prohibition of tobacco smoking. Further, Health & Safety Code section 11362.3 prohibits the smoking or use of cannabis or cannabis products in any place where smoking tobacco is prohibited.

I acknowledge that I am aware of the District's policy regarding tobacco-free environments at District sites, including the Project site and hereby certify that I will adhere to the requirements of that policy and not permit any of my firm's employees, agents, subcontractors, or my firm's subcontractors' employees or agents, to use tobacco and/or smoke on the Project site.

Date: \_\_\_\_\_  
Proper Name of Contractor: \_\_\_\_\_  
Signature: \_\_\_\_\_  
Print Name: \_\_\_\_\_  
Title: \_\_\_\_\_

END OF DOCUMENT

**DRUG AND ALCOHOL-FREE SCHOOLS CERTIFICATION**

PROJECT/CONTRACT NO.: **Stiern Middle School Spray Polyurethane Foam Roofing Project No. 26247.00-20-DM** between the Bakersfield City School District ("District") and \_\_\_\_\_ ("Contractor" or "Bidder")  
("Contract" or "Project").

Pursuant to, without limitation, District Board policies, all District sites, including the Project site, are drug and alcohol-free schools. Possession, use, or sale of drugs and alcohol is prohibited at any time in District-owned or leased buildings, on district property, and in District vehicles unless otherwise permitted by law.

I acknowledge that I am aware of the District's policy regarding drug and alcohol-free schools, including the Project site and hereby certify that I will adhere to the requirements of that policy and not permit any of my firm's employees, agents, subcontractors, or my firm's subcontractors' employees or agents, to possess, use or sell:

1. Any substance which may not lawfully be possessed, used, or sold in California.
2. Cannabis or cannabis products (Health and Safety Code, § 11362.3; 21 USC §§ 812, 844).
3. Alcohol beverages, unless approved by the Superintendent or designee for limited purposes specified in Business and Professions Code section 25608.

Date: \_\_\_\_\_

Proper Name of Contractor: \_\_\_\_\_

Signature: \_\_\_\_\_

Print Name: \_\_\_\_\_

Title: \_\_\_\_\_

END OF DOCUMENT

**LEAD-BASED MATERIALS CERTIFICATION**

PROJECT/CONTRACT NO.: **Stiern Middle School Spray Polyurethane Foam Roofing Project No. 26247.00-20-DM** between the Bakersfield City School District ("District") and \_\_\_\_\_ ("Contractor" or "Bidder") ("Contract" or "Project").

This certification provides notice to the Contractor that:

- (1) Contractor's work may disturb lead-containing building materials.
- (2) Contractor shall notify the District if any work may result in the disturbance of lead-containing building materials.
- (3) Contractor shall comply with the Renovation, Repair and Painting Rule, if lead-based paint is disturbed in a six-square-foot or greater area indoors or a 20-square-foot or greater area outdoors.

**1. Lead as a Health Hazard**

Lead poisoning is recognized as a serious environmental health hazard facing children today. Even at low levels of exposure, much lower than previously believed, lead can impair the development of a child's central nervous system, causing learning disabilities, and leading to serious behavioral problems. Lead enters the environment as tiny lead particles and lead dust disburse when paint chips, chalks, peels, wears away over time, or is otherwise disturbed. Ingestion of lead dust is the most common pathway of childhood poisoning; lead dust gets on a child's hands and toys and then into a child's mouth through common hand-to-mouth activity. Exposures may result from construction or remodeling activities that disturb lead paint, from ordinary wear and tear of windows and doors, or from friction on other surfaces.

Ordinary construction and renovation or repainting activities carried out without lead-safe work practices can disturb lead-based paint and create significant hazards. Improper removal practices, such as dry scraping, sanding, or water blasting painted surfaces, are likely to generate high volumes of lead dust.

Because the Contractor and its employees will be providing services for the District, and because the Contractor's work may disturb lead-containing building materials, CONTRACTOR IS HEREBY NOTIFIED of the potential presence of lead-containing materials located within certain buildings utilized by the District. All school buildings built prior to 1978 are presumed to contain some lead-based paint until sampling proves otherwise.

**2. Overview of California Law**

Education Code section 32240 et seq. is known as the Lead-Safe Schools Protection Act. Under this act, the Department of Health Services is to conduct a sample survey of schools in the State of California for the purpose of developing risk factors to predict lead contamination in public schools. (Ed. Code, § 32241.)

Any school that undertakes any action to abate existing risk factors for lead is required to utilize trained and state-certified contractors, inspectors, and workers. (Ed. Code, § 32243, subd. (b).) Moreover, lead-based paint, lead plumbing, and solders, or other potential sources of lead contamination, shall not be utilized in the construction of any new school facility or the modernization or renovation of any existing school facility. (Ed. Code, § 32244.)

Both the Federal Occupational Safety and Health Administration ("Fed/OSHA") and the California Division of Occupational Safety and Health ("Cal/OSHA") have implemented safety orders applicable to all construction work where a contractor's employee may be occupationally exposed to lead.

The OSHA Regulations apply to all construction work where a contractor's employee may be occupationally exposed to lead. The OSHA Regulations contain specific and detailed requirements imposed on contractors subject to those regulations. The OSHA Regulations define construction work as work for construction, alteration, and/or repair, including painting and decorating. Regulated work includes, but is not limited to, the following:

- a. Demolition or salvage of structures where lead or materials containing lead are present;
- b. Removal or encapsulation of materials containing lead;
- c. New construction, alteration, repair, or renovation of structures, substrates, or portions thereof, that contain lead, or materials containing lead;
- d. Installation of products containing lead;
- e. Lead contamination/emergency cleanup;
- f. Transportation, disposal, storage, or containment of lead or materials containing lead on the site or location at which construction activities are performed; and
- g. Maintenance operations associated with the construction activities described in the subsection.

Because it is assumed by the District that all painted surfaces (interior as well as exterior) within the District contain some level of lead, it is imperative that the Contractor, its workers and subcontractors fully and adequately comply with all applicable laws, rules and regulations governing lead-based materials (including title 8, California Code of Regulations, section 1532.1).

**Contractor shall notify the District if any Work may result in the disturbance of lead-containing building materials. Any and all Work that may result in the disturbance of lead-containing building materials shall be coordinated through the District. A signed copy of this Certification shall be on file prior to beginning Work on the Project, along with all current insurance certificates.**

**3. Renovation, Repair and Painting Rule, Section 402(c)(3) of the Toxic Substances Control Act**

The EPA requires lead safe work practices to reduce exposure to lead hazards created by renovation, repair and painting activities that disturb lead-based paint. Pursuant to the Renovation, Repair and Painting Rule (RRP), renovations in homes, childcare facilities, and schools built prior to 1978 must be conducted by certified renovations firms, using renovators with training by a EPA-accredited training provider, and fully and adequately complying with all applicable laws, rules and regulations governing lead-based materials, including those rules and regulations appearing within title 40 of the Code of Federal Regulations as part 745 (40 CFR 745).

The RRP requirements apply to all contractors who disturb lead-based paint in a six-square-foot or greater area indoors or a 20-square-foot or greater area outdoors. If a DPH-certified inspector or risk assessor determines that a home constructed before 1978 is lead-free, the federal certification is not required for anyone working on that particular building.

**4. Contractor's Liability**

If the Contractor fails to comply with any applicable laws, rules, or regulations, and that failure results in a site or worker contamination, the Contractor will be held solely responsible for all costs involved in any required corrective actions, and shall defend, indemnify, and hold harmless the District, pursuant to the indemnification provisions of the Contract, for all damages and other claims arising therefrom.

If lead disturbance is anticipated in the Work, only persons with appropriate accreditation, registrations, licenses, and training shall conduct this Work.

It shall be the responsibility of the Contractor to properly dispose of any and all waste products, including, but not limited to, paint chips, any collected residue, or any other visual material that may occur from the prepping of any painted surface. It will be the responsibility of the Contractor to provide the proper disposal of any hazardous waste by a certified hazardous waste hauler. This company shall be registered with the Department of Transportation (DOT) and shall be able to issue a current manifest number upon transporting any hazardous material from any school site within the District.

The Contractor shall provide the District with any sample results prior to beginning Work, during the Work, and after the completion of the Work. The District may request to examine, prior to the commencement of the Work, the lead training records of each employee of the Contractor.

THE CONTRACTOR HEREBY ACKNOWLEDGES, UNDER PENALTY OF PERJURY, THAT IT:

1. HAS RECEIVED NOTIFICATION OF POTENTIAL LEAD-BASED MATERIALS ON THE OWNER'S PROPERTY;
2. IS KNOWLEDGEABLE REGARDING AND WILL COMPLY WITH ALL APPLICABLE LAWS, RULES, AND REGULATIONS GOVERNING WORK WITH, AND DISPOSAL, OF LEAD.

THE UNDERSIGNED WARRANTS THAT HE/SHE HAS THE AUTHORITY TO SIGN ON BEHALF OF AND BIND THE CONTRACTOR. THE DISTRICT MAY REQUIRE PROOF OF SUCH AUTHORITY.

Date: \_\_\_\_\_

Proper Name of Contractor: \_\_\_\_\_

Signature: \_\_\_\_\_

Print Name: \_\_\_\_\_

Title: \_\_\_\_\_

END OF DOCUMENT

**CRIMINAL BACKGROUND INVESTIGATION/  
FINGERPRINTING CERTIFICATION**

PROJECT/CONTRACT NO.: **Stiern Middle School Spray Polyurethane Foam Roofing  
Project No. 26247.00-20-DM** between the Bakersfield City School District ("District") and \_\_\_\_\_ ("Contractor" or "Bidder")  
("Contract" or "Project").

The undersigned does hereby certify to the District that I am a representative of the Contractor currently under contract with the District; that I am familiar with the facts herein certified; and that I am authorized and qualified to execute this certificate on behalf of Contractor.

Contractor certifies that it has taken at least one of the following actions (check all that apply):

- Pursuant to Education Code section 45125.2(a), Contractor has installed or will install, prior to commencement of Work, a physical barrier at the Work Site, that will limit contact between Contractor's employees, Subcontractors or suppliers and District pupils at all times; and/or
- Pursuant to Education Code section 45125.2(a), Contractor certifies that all employees will be under the continual supervision of, and monitored by, an employee of the Contractor who the California Department of Justice ("DOJ") has ascertained, or as described below, will ascertain, has not been convicted of a violent or serious felony. The name and title of the employee who will be supervising Contractor's and its subcontractors' or suppliers' employees is:

Name: \_\_\_\_\_

Title: \_\_\_\_\_

**NOTE:** If Contractor is a sole proprietor, and elects the above option, Contractor must have the above-named employee's fingerprints prepared and submitted by District for submission to the DOJ, in accordance with Education Code section 45125.1(h). No work shall commence until such determination by DOJ has been made.

- Pursuant to Education Code section 45125.2(a), the District will take appropriate steps to protect the safety of any pupils that may come in contact with Contractor's employees, subcontractors or suppliers so that the fingerprinting and criminal background investigation requirements of Education Code section 45125.2 shall not apply to Contractor under the Contract.
- The Work on the Contract is either (i) at an unoccupied school site and no employee of Contractor and/or subcontractor or supplier of any tier of the Contract shall come in contact with the District pupils or (ii) if Contractor's employees or any subcontractor or supplier of any tier of the Contract interacts with pupils, such interaction shall only take place under the immediate supervision and control of the pupil's parent or guardian or a school employee, so that the fingerprinting and criminal background investigation requirements of Education Code section 45125.1 shall not apply to Contractor under the Contract.

- The Contractor, who is not a sole proprietor, has complied with the fingerprinting requirements of Education Code section 45125.1 with respect to all Contractor's employees and all of its Subcontractors' employees who may have contact with District pupils in the course of providing services pursuant to the Contract, and the DOJ has determined (A) that none of those employees has been convicted of a felony, as that term is defined in Education Code section 45122.1 and/or (B) that the prohibition does not apply to an employee as provided by Education Code section 45125.1(e)(2) or (3). When the Contractor performs the criminal background check, it shall immediately provide any subsequent arrest and conviction information it receives to the District pursuant to the subsequent arrest service. No work shall commence until the Department of Justice ascertains that Contractor's employees and any subcontractors' employees have not been convicted of a felony as defined in Education Code Section 45122.1.

**A complete and accurate list of Contractor's employees and of all of its subcontractors' employees who may come in contact with District pupils during the course and scope of the Contract is attached hereto as ATTACHMENT "A;" and/or**

- The Contractor is a sole proprietor and intends to comply with the fingerprinting requirements of Education Code section 45125.1(h) with respect to all Contractor's employees who may have contact with District pupils in the course of providing services pursuant to the Contract, and hereby agrees to the District's preparation and submission of fingerprints such that the DOJ may determine (A) that none of those employees has been convicted of a felony, as that term is defined in Education Code section 45122.1 and/or (B) that the prohibition does not apply to an employee as provided by Education Code section 45125.1(e)(2) or (3). No work shall commence until the Department of Justice ascertains that Contractor's employees and any subcontractors' employees have not been convicted of a felony as defined in Education Code Section 45122.1.

Contractor's responsibility for background clearance extends to all of its employees, Subcontractors or suppliers, and employees of Subcontractors or suppliers coming into contact with District pupils regardless of whether they are designated as employees or acting as independent contractors of the Contractor.

Date: \_\_\_\_\_  
Proper Name of Contractor: \_\_\_\_\_  
Signature: \_\_\_\_\_  
Print Name: \_\_\_\_\_  
Title: \_\_\_\_\_

[CONTINUED ON NEXT PAGE]

**ATTACHMENT "A"**

**List of Employees/Subcontractors**

**Name/Company:** \_\_\_\_\_

**Name/Company:** \_\_\_\_\_

**Name/Company:** \_\_\_\_\_

**Name/Company:** \_\_\_\_\_

**Name/Company:** \_\_\_\_\_

**Name/Company:** \_\_\_\_\_

**Name/Company:** \_\_\_\_\_

**Name/Company:** \_\_\_\_\_

**Name/Company:** \_\_\_\_\_

**Name/Company:** \_\_\_\_\_

**Name/Company:** \_\_\_\_\_

**Name/Company:** \_\_\_\_\_

**Name/Company:** \_\_\_\_\_

**Name/Company:** \_\_\_\_\_

**Name/Company:** \_\_\_\_\_

**Name/Company:** \_\_\_\_\_

**Name/Company:** \_\_\_\_\_

**Name/Company:** \_\_\_\_\_

**Name/Company:** \_\_\_\_\_

**Name/Company:** \_\_\_\_\_

**Name/Company:** \_\_\_\_\_

If further space is required for the list of employees/subcontractors, attach additional copies of this page.

END OF DOCUMENT



By my signature below, I hereby certify that, to the best of my knowledge, the contents of this disclosure are true, or are believed to be true. I further certify on behalf of the Firm that I am aware of section 3000 et seq. of the California Public Contract Code, and the sections referenced therein regarding the penalties for providing false information or failing to disclose a financial relationship in this disclosure. I further certify that I am authorized to make this certification on behalf of the Firm.

Date: \_\_\_\_\_

Proper Name of Firm: \_\_\_\_\_

Signature: \_\_\_\_\_

Print Name: \_\_\_\_\_

Title: \_\_\_\_\_

END OF DOCUMENT

**DIR REGISTRATION VERIFICATION**  
**(Labor Code Section 1771.1)**

PROJECT: **Stiern Middle School Spray Polyurethane Foam Roofing Project No. 26247.00-20-DM**

Date Submitted (for Updates): \_\_\_\_\_

Contractor acknowledges and agrees that it must clearly set forth below the name and Department of Industrial Relations (DIR) registration number of each subcontractor **for all tiers** who will perform work or labor or render service to Contractor or its subcontractors in or about the construction of the Work **at least two (2) weeks before the subcontractor is scheduled to perform work**. This document is to be updated as all tiers of subcontractors are identified.

Contractor acknowledges and agrees that, if Contractor fails to list as to any subcontractor of any tier who performs any portion of Work, the Contract is subject to cancellation and the Contractor will be subjected to penalty under applicable law.

If further space is required for the list of proposed subcontractors, attach additional copies of page 2 showing the required information, as indicated below.

**Subcontractor Name:** \_\_\_\_\_

DIR Registration #: \_\_\_\_\_

Portion of Work: \_\_\_\_\_

**Subcontractor Name:** \_\_\_\_\_

DIR Registration #: \_\_\_\_\_

Portion of Work: \_\_\_\_\_

**Subcontractor Name:** \_\_\_\_\_

DIR Registration #: \_\_\_\_\_

Portion of Work: \_\_\_\_\_

**Subcontractor Name:** \_\_\_\_\_

DIR Registration #: \_\_\_\_\_

Portion of Work: \_\_\_\_\_

**Subcontractor Name:** \_\_\_\_\_

DIR Registration #: \_\_\_\_\_

Portion of Work: \_\_\_\_\_

**Subcontractor Name:** \_\_\_\_\_

DIR Registration #: \_\_\_\_\_

Portion of Work: \_\_\_\_\_

**Subcontractor Name:** \_\_\_\_\_

DIR Registration #: \_\_\_\_\_

Portion of Work: \_\_\_\_\_

**Subcontractor Name:** \_\_\_\_\_

DIR Registration #: \_\_\_\_\_

Portion of Work: \_\_\_\_\_

**Subcontractor Name:** \_\_\_\_\_

DIR Registration #: \_\_\_\_\_

Portion of Work: \_\_\_\_\_

**Subcontractor Name:** \_\_\_\_\_

DIR Registration #: \_\_\_\_\_

Portion of Work: \_\_\_\_\_

**Subcontractor Name:** \_\_\_\_\_

DIR Registration #: \_\_\_\_\_

Portion of Work: \_\_\_\_\_

**Subcontractor Name:** \_\_\_\_\_

DIR Registration #: \_\_\_\_\_

Portion of Work: \_\_\_\_\_

Date: \_\_\_\_\_

Name of Contractor: \_\_\_\_\_

Signature: \_\_\_\_\_

Print Name: \_\_\_\_\_

Title: \_\_\_\_\_

END OF DOCUMENT

**AGREEMENT**

THIS AGREEMENT IS MADE AND ENTERED INTO THIS \_\_\_\_\_ DAY OF \_\_\_\_\_  
\_\_\_\_\_, 20\_\_\_\_, by and between the Bakersfield City School District ("District") and \_\_\_\_\_  
\_\_\_\_\_ ("Contractor") ("Agreement").

**WITNESSETH:** That the parties hereto have mutually covenanted and agreed, and by these presents do covenant and agree with each other, as follows:

- 1. The Work:** Contractor agrees to furnish all tools, equipment, apparatus, facilities, labor, and material necessary to perform and complete in a good and workmanlike manner, the work of the following project:

**Stiern Middle School Spray Polyurethane Foam Roofing Project No.  
26247.00-20-DM**

("Project" or "Contract" or "Work")

It is understood and agreed that the Work shall be performed and completed as required in the Contract Documents including, without limitation, the Drawings and Specifications and submission of all documents required to secure funding or by the Division of the State Architect for close-out of the Project, under the direction and supervision of, and subject to the approval of, the District or its authorized representative.

- 2. The Contract Documents:** The complete Contract consists of all Contract Documents as defined in the General Conditions and incorporated herein by this reference. Any and all obligations of the District and Contractor are fully set forth and described in the Contract Documents. All Contract Documents are intended to cooperate so that any Work called for in one and not mentioned in the other or vice versa is to be executed the same as if mentioned in all Contract Documents.
- 3. Interpretation of Contract Documents:** Should any question arise concerning the intent or meaning of Contract Documents, including the Drawings or Specifications, the question shall be submitted to the District for interpretation. If a conflict exists in the Contract Documents, valid, written modifications, beginning with the most recent, shall control over this Agreement (if any), which shall control over the Special Conditions, which shall control over any Supplemental Conditions, which shall control over the General Conditions, which shall control over the remaining Division 0 documents, which shall control over Division 1 Documents which shall control over Division 2 through Division 49 documents, which shall control over figured dimensions, which shall control over large-scale drawings, which shall control over small-scale drawings. In the case of a discrepancy or ambiguity solely between and among the Drawings and Specifications, the discrepancy or ambiguity shall be resolved in favor of the interpretation that will provide District with the functionally complete and operable Project described in the Drawings and Specifications. In no case shall a document calling for lower quality and/or quantity material or workmanship control. The decision of the District in the matter shall be final.

4. **Time for Completion:** It is hereby understood and agreed that the Work under this Contract shall be completed **per attachment S Baseline Bid Schedule** ("Contract Time") from the date specified in the District's Notice to Proceed.
5. **Completion - Extension of Time:** Should the Contractor fail to complete this Contract, and the Work provided herein, within the time fixed for completion, due allowance being made for the contingencies provided for herein, the Contractor shall become liable to the District for all loss and damage that the District may suffer on account thereof. The Contractor shall coordinate its Work with the Work of all other contractors. The District shall not be liable for delays resulting from Contractor's failure to coordinate its Work with other contractors in a manner that will allow timely completion of Contractor's Work. Contractor shall be liable for delays to other contractors caused by Contractor's failure to coordinate its Work with the Work of other contractors.
6. **Liquidated Damages:** Time is of the essence for all work under this Agreement. It is hereby understood and agreed that it is and will be difficult and/or impossible to ascertain and determine the actual damage that the District will sustain in the event of and by reason of Contractor's delay; therefore, Contractor agrees that it shall pay to the District the sum of one thousand dollars (\$1,000.00) per day as liquidated damages for each and every day's delay beyond the time herein prescribed in completion of the Work.

It is hereby understood and agreed that this amount is not a penalty.

In the event that any portion of the liquidated damages is not paid to the District, the District may deduct that amount from any money due or that may become due the Contractor under this Agreement, and such deduction does not constitute a withholding or penalty. The District's right to assess liquidated damages is as indicated herein and in the General Conditions.

The time during which the Contract is delayed for cause, as hereinafter specified, may extend the time of completion for a reasonable time as the District may grant, provided that Contractor has complied with the claims procedure of the Contract Documents. This provision does not exclude the recovery of damages by either party under other provisions in the Contract Documents.

7. **Loss Or Damage:** The District and its agents and authorized representatives shall not in any way or manner be answerable or suffer loss, damage, expense, or liability for any loss or damage that may happen to the Work, or any part thereof, or in or about the same during its construction and before acceptance, and the Contractor shall assume all liabilities of every kind or nature arising from the Work, either by accident, negligence, theft, vandalism, or any cause whatsoever; and shall hold the District and its agents and authorized representatives harmless from all liability of every kind and nature arising from accident, negligence, or any cause whatsoever.
8. **Limitation Of District Liability:** District's financial obligations under this Contract shall be limited to the payment of the compensation provided in this Contract. Notwithstanding any other provision of this Contract, in no event shall District be liable, regardless of whether any claim is based on contract or tort, for any special, consequential, indirect or incidental damages, including, but not limited to, lost profits or revenue, lost bonding capacity, arising out of or in connection with this Contract for the services performed in connection with this Contract.

9. **Insurance and Bonds:** Prior to issuance of the Notice to Proceed by the District, Contractor shall provide all required certificates of insurance, insurance endorsements, and payment and performance bonds as evidence thereof.
10. **Prosecution of Work:** If the Contractor should neglect to prosecute the Work properly or fail to perform any provisions of this Contract, the District, may, pursuant to the General Conditions and without prejudice to any other remedy it may have, make good such deficiencies and may deduct the cost thereof from the payment then or thereafter due the Contractor.
11. **Authority of Architect, Project Inspector, and DSA:** Contractor hereby acknowledges that the Architect(s), the Project Inspector(s), and the Division of the State Architect ("DSA") have authority to approve and/or suspend Work if the Contractor's Work does not comply with the requirements of the Contract Documents, Title 24 of the California Code of Regulations, and all applicable laws and regulations. The Contractor shall be liable for any delay caused by its non-compliant Work.
12. **Assignment of Contract:** Neither the Contract, nor any part thereof, nor any moneys due or to become due thereunder, may be assigned by the Contractor without the prior written approval of the District, nor without the written consent of the Surety on the Contractor's Performance Bond (the "Surety"), unless the Surety has waived in writing its right to notice of assignment.
13. **Classification of Contractor's License:** Contractor hereby acknowledges that it currently holds valid Type "**C-39**" Contractor's license(s) issued by the State of California, Contractors' State License Board, in accordance with division 3, chapter 9, of the Business and Professions Code and in the classification called for in the Contract Documents.
14. **Registration as Public Works Contractor:** The Contractor and all Subcontractors currently are registered as public works contractors with the Department of Industrial Relations, State of California, in accordance with Labor Code section 1771.1.
15. **Payment of Prevailing Wages:** The Contractor and all Subcontractors shall pay all workers on all Work performed pursuant to this Contract not less than the general prevailing rate of per diem wages and the general prevailing rate for holiday and overtime work as determined by the Director of the Department of Industrial Relations, State of California, for the type of work performed and the locality in which the work is to be performed within the boundaries of the District, pursuant to sections 1770 et seq. of the California Labor Code.
16. **Labor Compliance Monitoring and Enforcement:** This Project is subject to labor compliance monitoring and enforcement by the Department of Industrial Relations pursuant to Labor Code section 1771.4 and Title 8 of the California Code of Regulations. Contractor specifically acknowledges and understands that it shall perform the Work of this Agreement while complying with all the applicable provisions of Division 2, Part 7, Chapter 1, of the Labor Code, including, without limitation, the requirement that the Contractor and all of its Subcontractors shall timely submit complete and accurate electronic certified payroll records as required by the Contract Documents, or the District may not issue payment.

**17. Contract Price:** In consideration of the foregoing covenants, promises, and agreements on the part of the Contractor, and the strict and literal fulfillment of each and every covenant, promise, and agreement, and as compensation agreed upon for the Work and construction, erection, and completion as aforesaid, the District covenants, promises, and agrees that it will well and truly pay and cause to be paid to the Contractor in full, and as the full Contract Price and compensation for construction, erection, and completion of the Work hereinabove agreed to be performed by the Contractor, the following price:

\_\_\_\_\_ **Dollars**

(\$ \_\_\_\_\_),

in lawful money of the United States, which sum is to be paid according to the schedule provided by the Contractor and accepted by the District and subject to additions and deductions as provided in the Contract. This amount supersedes any previously stated and/or agreed to amount(s).

**18. No Representations:** No representations have been made other than as set forth in writing in the Contract Documents, including this Agreement. Each of the Parties to this Agreement warrants that it has carefully read and understood the terms and conditions of this Agreement and all Contract Documents, and that it has not relied upon the representations or advice of any other Party or any attorney not its own.

**19. Entire Agreement:** The Contract Documents, including this Agreement, set forth the entire agreement between the parties hereto and fully supersede any and all prior agreements, understandings, written or oral, between the parties hereto pertaining to the subject matter thereof.

**20. Severability:** If any term, covenant, condition, or provision in any of the Contract Documents is held by a court of competent jurisdiction to be invalid, void or unenforceable, the remainder of the provisions in the Contract Documents shall remain in full force and effect and shall in no way be affected, impaired, or invalidated thereby.

**21. Authority of Signatories:** Each party has the full power and authority to enter into and perform this Contract, and the person signing this Contract on behalf of each party has been properly authorized and empowered to enter into this Contract. This Contract may be executed in one or more counterparts, each of which shall be deemed an original. For this Agreement, and for all Contract Documents requiring a signature, a facsimile or electronic signature shall be deemed to be the equivalent of the actual original signature. All counterparts so executed shall constitute one Contract binding all the Parties hereto.

**22. Compliance with Law.** The Parties shall observe and comply with all applicable county, state and federal laws, ordinances, rules and regulations now in effect or hereafter enacted, each of which are hereby made a part hereof and incorporated herein by reference. Contractor shall observe and comply with all rules and regulations of the Board of the District and all federal, state, and local laws, ordinances and regulations. Contractor shall give all notices required by any law, ordinance, rule and regulation bearing on conduct of their staff and representatives. If Contractor observes that any of the Services required by this Agreement are at variance with any such laws, ordinance, rules or regulations, Contractor shall notify the District, in writing, and, at the sole option of the District, any necessary changes to the scope shall be made and this Agreement shall be appropriately amended in writing, or this Agreement shall be terminated effective upon Contractor's receipt of a written termination notice from the District.

IN WITNESS WHEREOF, accepted and agreed on the date indicated above:

**CONTRACTOR NAME**

**BAKERSFIELD CITY SCHOOL DISTRICT**

By: \_\_\_\_\_

By: \_\_\_\_\_

Print Name: \_\_\_\_\_

Print Name: Leonard Zasoski, Jr.

Title: \_\_\_\_\_

Title: Assistant Director II, M.O.F

NOTE: If the party executing this Contract is a corporation, a certified copy of the by-laws, or of the resolution of the Board of Directors, authorizing the officers of said corporation to execute the Contract and the bonds required thereby must be attached hereto.

END OF DOCUMENT

**PERFORMANCE BOND**  
**(100% of Contract Price)**

**(Note: Contractor must use this form, NOT a surety company form.)**

KNOW ALL PERSONS BY THESE PRESENTS:

WHEREAS, the governing board ("Board") of the Bakersfield City School District, ("District") and \_\_\_\_\_ ("Principal") have entered into a contract for the furnishing of all materials and labor, services and transportation, necessary, convenient, and proper to perform the following project:

**Stiern Middle School Spray Polyurethane Foam Roofing Project No. 26247.00-20-DM**

("Project" or "Contract") which Contract dated \_\_\_\_\_, 20\_\_\_\_, and all of the Contract Documents attached to or forming a part of the Contract, are hereby referred to and made a part hereof; and

WHEREAS, said Principal is required under the terms of the Contract to furnish a bond for the faithful performance of the Contract.

NOW, THEREFORE, the Principal and \_\_\_\_\_ ("Surety") are held and firmly bound unto the Board of the District in the penal sum of

\_\_\_\_\_ Dollars (\$\_\_\_\_\_), lawful money of the United States, for the payment of which sum well and truly to be made we bind ourselves, our heirs, executors, administrators, successors, and assigns jointly and severally, firmly by these presents, to:

- Promptly perform all the work required to complete the Project; and
- Pay to the District all damages the District incurs as a result of the Principal's failure to perform all the Work required to complete the Project.

Or, at the District's sole discretion and election, the Surety shall obtain a bid or bids for completing the Contract in accordance with its terms and conditions, and upon determination by the District of the lowest responsible bidder, arrange for a contract between such bidder and the District and make available as Work progresses sufficient funds to pay the cost of completion less the "balance of the Contract Price," and to pay and perform all obligations of Principals under the Contract, including, without limitation, all obligations with respect to warranties, guarantees and the payment of liquidated damages. The term "balance of the Contract Price," as used in this paragraph, shall mean the total amount payable to Principal by the District under the Contract and any modifications thereto, less the amount previously paid by the District to the Principal, less any withholdings by the District allowed under the Contract. District shall not be required or obligated to accept a tender of a completion contractor from the Surety for any or no reason.

The condition of the obligation is such that, if the above bound Principal, its heirs, executors, administrators, successors, or assigns, shall in all things stand to and abide by, and well and truly

keep and perform the covenants, conditions, and agreements in the Contract and any alteration thereof made as therein provided, on its part to be kept and performed at the time and in the intent and meaning, including all contractual guarantees and warranties of materials and workmanship, and shall indemnify and save harmless the District, its trustees, officers and agents, as therein stipulated, then this obligation shall become null and void, otherwise it shall be and remain in full force and virtue.

Surety expressly agrees that the District may reject any contractor or subcontractor proposed by Surety to fulfill its obligations in the event of default by the Principal. Surety shall not utilize Principal in completing the Work nor shall Surety accept a Bid from Principal for completion of the Work if the District declares the Principal to be in default and notifies Surety of the District's objection to Principal's further participation in the completion of the Work.

As a condition precedent to the satisfactory completion of the Contract, the above obligation shall hold good for a period equal to the warranty and/or guarantee period of the Contract, during which time Surety's obligation shall continue if Contractor shall fail to make full, complete, and satisfactory repair and replacements and totally protect the District from loss or damage resulting from or caused by defective materials or faulty workmanship. The obligations of Surety hereunder shall continue so long as any obligation of Contractor remains. Nothing herein shall limit the District's rights or the Contractor or Surety's obligations under the Contract, law or equity, including, but not limited to, California Code of Civil Procedure section 337.15.

The Surety, for value received, hereby stipulates and agrees that no change, extension of time, alteration, or addition to the terms of the contract or to the work to be performed thereunder or the specifications accompanying the same shall in any way affect its obligation on this bond. The Surety also stipulates and agrees that it shall not be exonerated or released from the obligation of this bond by any overpayment or underpayment by the District that is based upon estimates approved by the Architect. The Surety does hereby waive notice of any such change, extension of time, alteration, or addition to the terms of the Contract or to the work or to the specifications.

IN WITNESS WHEREOF, two (2) identical counterparts of this instrument, each of which shall for all purposes be deemed an original thereof, have been duly executed by the Principal and Surety above named, on the \_\_\_\_\_ day of \_\_\_\_\_, 20\_\_.

_____	Principal	_____	Surety
_____	By	_____	By
		_____	Name of California Agent of Surety
		_____	Address of California Agent of Surety
		_____	Telephone No. of California Agent of Surety

**Contractor must attach a Notarial Acknowledgment for all Surety's signatures and a Power of Attorney and Certificate of Authority for Surety. The California Department of Insurance must authorize the Surety to be an admitted surety insurer.**

END OF DOCUMENT

**PAYMENT BOND**  
**Contractor's Labor & Material Bond**  
**(100% Of Contract Price)**

**(Note: Contractor must use this form, NOT a surety company form.)**

KNOW ALL PERSONS BY THESE PRESENTS:

WHEREAS, the governing board ("Board") of the Bakersfield City School District, ("District") and \_\_\_\_\_, ("Principal") have entered into a contract for the furnishing of all materials and labor, services and transportation, necessary, convenient, and proper to perform the following project:

**Stiern Middle School Spray Polyurethane Foam Roofing Project No. 26247.00-20-DM**

("Project" or "Contract") which Contract dated \_\_\_\_\_, 20\_\_\_\_, and all of the Contract Documents attached to or forming a part of the Contract, are hereby referred to and made a part hereof; and

WHEREAS, pursuant to law and the Contract, the Principal is required, before entering upon the performance of the work, to file a good and sufficient bond with the body by which the Contract is awarded in an amount equal to one hundred percent (100%) of the Contract price, to secure the claims to which reference is made in sections 9000 through 9510 and 9550 through 9566 of the Civil Code, and division 2, part 7, of the Labor Code.

NOW, THEREFORE, the Principal and \_\_\_\_\_ ("Surety") are held and firmly bound unto all laborers, material men, and other persons referred to in said statutes in the sum of \_\_\_\_\_ Dollars (\$\_\_\_\_\_), lawful money of the United States, being a sum not less than the total amount payable by the terms of Contract, for the payment of which sum well and truly to be made, we bind ourselves, our heirs, executors, administrators, successors, or assigns, jointly and severally, by these presents.

The condition of this obligation is that if the Principal or any of its subcontractors, or their heirs, executors, administrators, successors, or assigns of any, all, or either of them shall fail to pay for any labor, materials, provisions, or other supplies, used in, upon, for or about the performance of the work contracted to be done, or for any work or labor thereon of any kind, or for amounts required to be deducted, withheld, and paid over to the Employment Development Department from the wages of employees of the Principal or any of his or its subcontractors of any tier under Section 13020 of the Unemployment Insurance Code with respect to such work or labor, that the Surety will pay the same in an amount not exceeding the amount herein above set forth, and also in case suit is brought upon this bond, will pay a reasonable attorney's fee to be awarded and fixed by the court, and to be taxed as costs and to be included in the judgment therein rendered.

It is hereby expressly stipulated and agreed that this bond shall inure to the benefit of any and all persons, companies, and corporations entitled to file claims under section 9100 of

the Civil Code, so as to give a right of action to them or their assigns in any suit brought upon this bond.

Should the condition of this bond be fully performed, then this obligation shall become null and void; otherwise it shall be and remain in full force and affect.

And the Surety, for value received, hereby stipulates and agrees that no change, extension of time, alteration, or addition to the terms of Contract or the specifications accompanying the same shall in any manner affect its obligations on this bond, and it does hereby waive notice of any such change, extension, alteration, or addition.

IN WITNESS WHEREOF, two (2) identical counterparts of this instrument, each of which shall for all purposes be deemed an original thereof, have been duly executed by the Principal and Surety above named, on the \_\_\_\_\_ day of \_\_\_\_\_, 20\_\_.

_____	_____
Principal	Surety
_____	_____
By	By
	_____
	Name of California Agent of Surety
	_____
	Address of California Agent of Surety
	_____
	Telephone No. of California Agent of Surety

**Contractor must attach a Notarial Acknowledgment for all Surety's signatures and a Power of Attorney and Certificate of Authority for Surety. The California Department of Insurance must authorize the Surety to be an admitted surety insurer.**

END OF DOCUMENT

**CHANGE ORDER FORM**

Bakersfield City School District  
 1501 Feliz Drive  
 Bakersfield, CA 93307

<b>CHANGE ORDER NO.:</b>

**CHANGE ORDER**

**Project: Stiern Middle School Spray Polyurethane Foam Roofing**      **Date:** \_\_\_\_\_  
**Bid No.: 26247.00-20-DM**

The following parties agree to the terms of this Change Order:

**Owner:** \_\_\_\_\_  
 [Name / Address]  
 \_\_\_\_\_  
 \_\_\_\_\_

**Contractor:** \_\_\_\_\_  
 [Name / Address]  
 \_\_\_\_\_  
 \_\_\_\_\_

**Architect: N/A**  
 [Name / Address]  
 \_\_\_\_\_  
 \_\_\_\_\_

**Project Inspector: N/A**  
 [Name / Address]  
 \_\_\_\_\_  
 \_\_\_\_\_

Reference	Description	Cost	Days Ext.
PCO # Requested by: Performed by: Reason:	[Description of change] [Requester] [Performer] [Reason]	\$	
PCO # Requested by: Performed by: Reason:	[Description of change] [Requester] [Performer] [Reason]	\$	
PCO # Requested by: Performed by: Reason:	[Description of change] [Requester] [Performer] [Reason]	\$	
Contract time will be adjusted as follows:  Previous Completion Date: __[Date]  _____[#] Calendar Days Extension (zero unless otherwise indicated)  Current Completion Date: __[Date]		Original Contract Amount:	\$
		Amount of Previously Approved Change Order(s):	\$
		Amount of this Change Order:	\$
		Contract Amount:	\$

The undersigned Contractor approves the foregoing as to the changes, if any, to the Contract Price specified for each item, and as to the extension of time allowed, if any, for



**GUARANTEE FORM**

\_\_\_\_\_ ("Contractor") hereby agrees that the \_\_\_\_\_  
\_\_\_\_\_ ("Work" of Contractor) which Contractor has installed for the Bakersfield City  
School District ("District") for the following project:

**PROJECT: Stiern Middle School Spray Polyurethane Foam Roofing Project No.  
26247.00-20-DM**

("Project" or "Contract") has been performed in accordance with the requirements of the  
Contract Documents and that the Work as installed will fulfill the requirements of the  
Contract Documents.

The undersigned agrees to repair or replace any or all of such Work that may prove to be  
defective in workmanship or material together with any other adjacent Work that may be  
displaced in connection with such replacement within a period of one year(s) from the date  
of completion as defined in Public Contract Code section 7107, subdivision (c), ordinary  
wear and tear and unusual abuse or neglect excepted. The date of completion is  
\_\_\_\_\_, 20\_\_.

In the event of the undersigned's failure to comply with the above-mentioned conditions  
within a reasonable period of time, as determined by the District, but not later than seven  
(7) days after being notified in writing by the District, the undersigned authorizes the  
District to proceed to have said defects repaired and made good at the expense of the  
undersigned. The undersigned shall pay the costs and charges therefor upon demand.

Date: \_\_\_\_\_

Proper Name of Contractor: \_\_\_\_\_

Signature: \_\_\_\_\_

Print Name: \_\_\_\_\_

Title: \_\_\_\_\_

Representatives to be contacted for service subject to terms of Contract:

Name: \_\_\_\_\_

Address: \_\_\_\_\_

Phone No.: \_\_\_\_\_

Email: \_\_\_\_\_

END OF DOCUMENT