



01-1484

Date: 06/5/2026

Submittal No: 9.2

Project: William Penn ES Mod.
BP-02 General
2201 San Emidio St.
Bakersfield, CA 93304

Owner: Bakersfield City School District
1300 Baker St.
Bakersfield, CA 93304

Architect: SCArchitect, Inc.
1601 New Stine Rd. Ste. 280
Bakersfield, CA 93309

Contractor: JTS Construction
P.O. Box 41765
Bakersfield, CA 93384-1765

Subcontractor: Action Glass

Submittal: Storefront/Glass/Windows

Contractor's Stamp

JTS CONSTRUCTION

BY: Omar Cabral

DATE: 6/5/2026

REVIEWED/RESUBMIT

Architect's Stamp

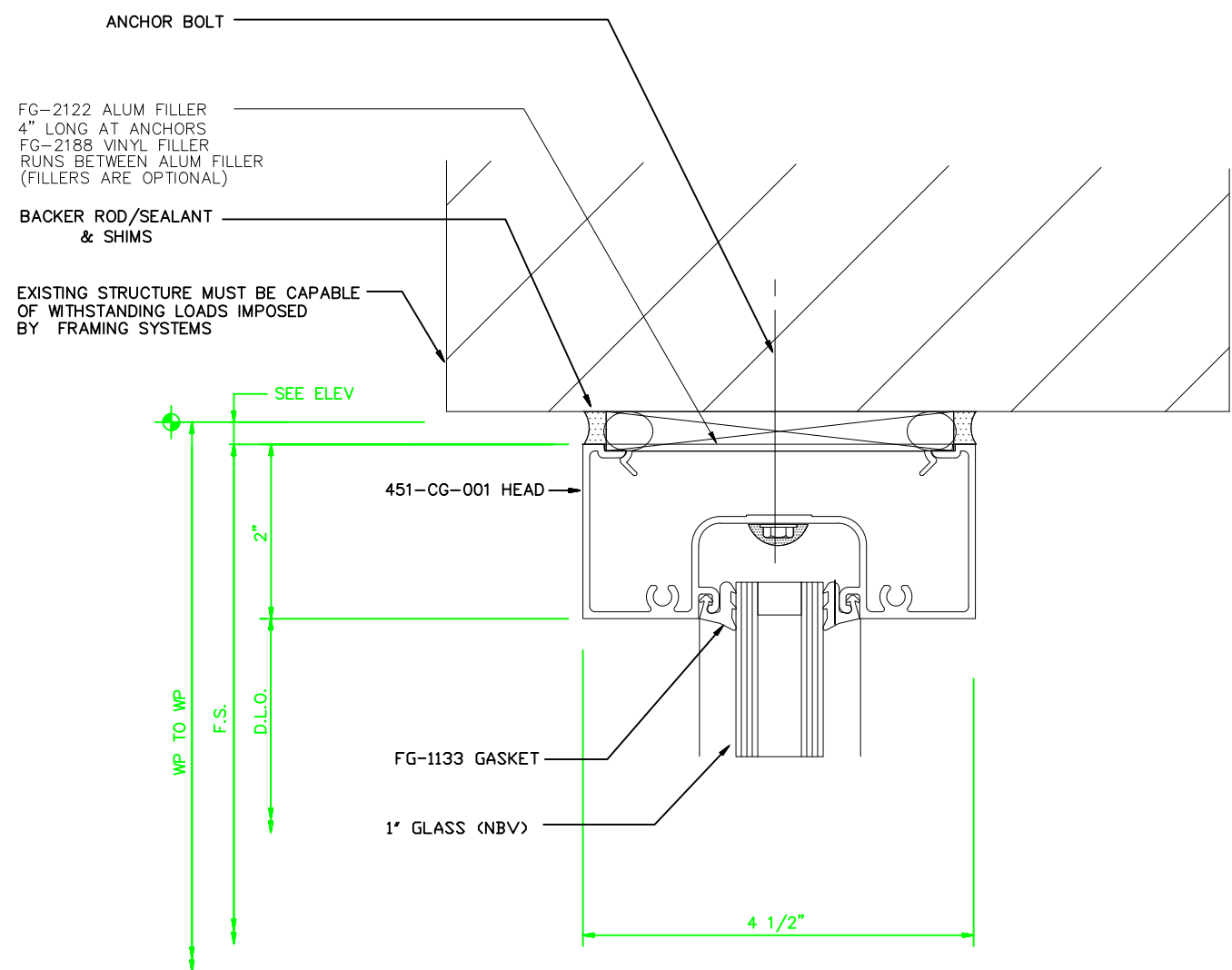
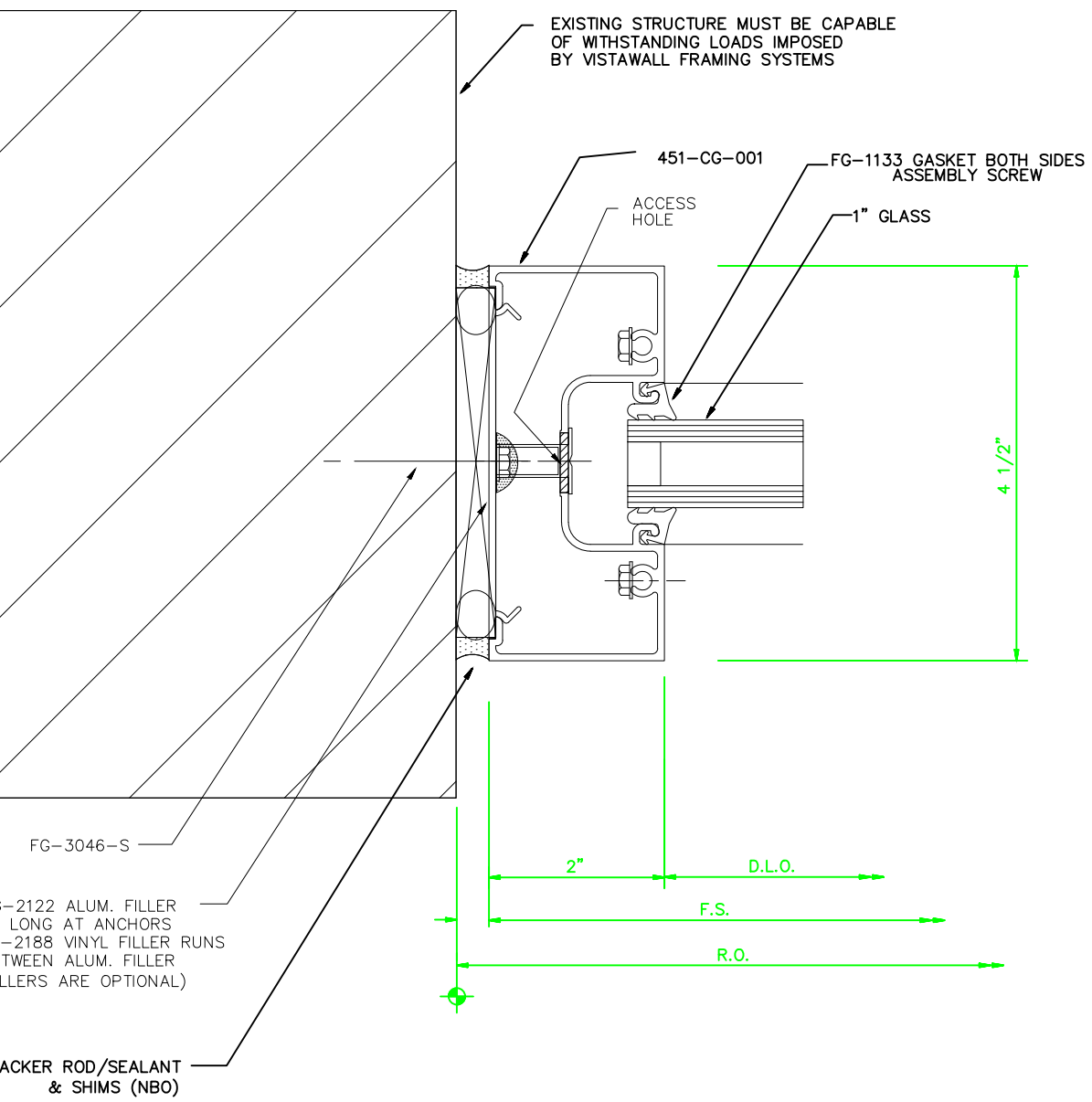
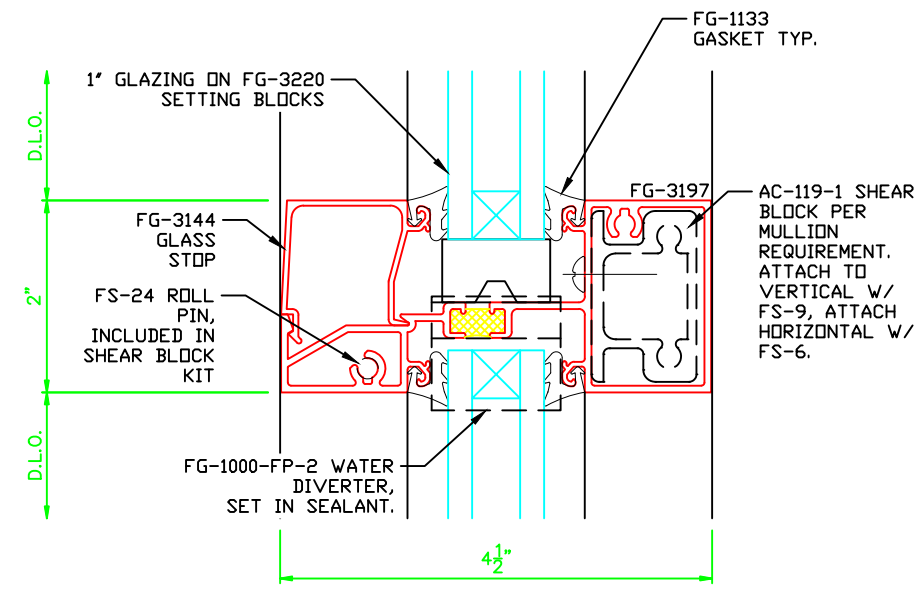
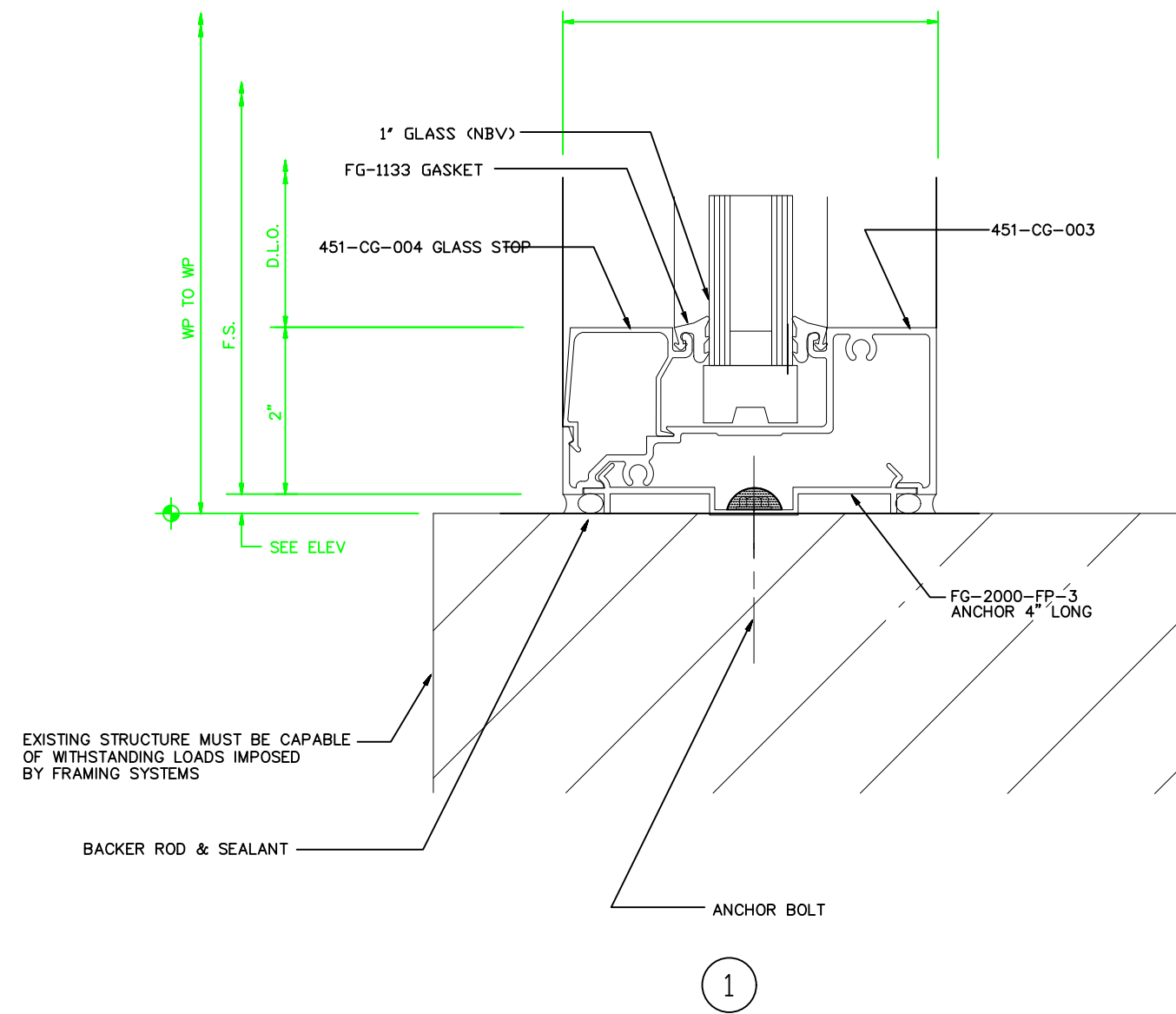

NOT USED

1 JB 6/4/26 UPDATED MFR

ACTION GLASS INC.
2300 Q ST.
BAKERSFIELD, CA.
661-633-9618

PROJECT William Penn ES
CUSTOMER JTS Modular
ARCHITECT SC Architects

DRAWN JB DATE 5/26/26

SCALE 6" = 1'

DRAWING NO.

SHEET D1

REV BY DATE DESCRIPTION

7500 SERIES

Institutional Door Closer



Norton[®]
ASSA ABLOY

ASSA ABLOY, the global leader
in door opening solutions

OVERVIEW

The 7500 Series Door Closer offers customers the ideal combination of superior performance, strength and quality. Ideal for interior or exterior doors in facilities that demand reliability.

Features

- Tri-Style® packaging; tri-packed for regular, top jamb or parallel arm mounting
- Non-handed
- Rack-and-pinion design
- Cast aluminum body
- Adjustable spring sizes 1-6
- 2-3/16" (56mm) projection
- 1-1/2" (38mm) diameter piston
- 5/8" (16mm) diameter pinion journals
- Staked valves
- Corrosion resistant model (non-hold open only). Specify 7500SS
- Metal cover. Specify M suffix
- Lead lined metal cover. Specify MLL suffix
- Retrofit plates
- NorGlide® fluid
- Molded plastic cover
- All standard arm applications allow doors to swing 180°, conditions permitting
- Self-drilling screws
- Full-size template
- Application specific mounting: Regular (S), Top Jamb (JS) or Parallel (P) mount
- Heavy-duty arms: Regular Rigid, Parallel Rigid, CloserPlus®, CloserPlus Spring™ and Unitrol®
- Slide Tracks: push or pull side mounting
- Exceeds 25 million cycles (witnessed and verified by UL)
- 25-year limited warranty

Functions

- Standard, separate and independent, latch, sweep and backcheck intensity valves
- Backcheck positioning
- Enhanced backcheck. Specify EBC suffix
- Delayed action with pressure relief valve

TABLE OF CONTENTS

Overview	2-3
How to Order	4
Fasteners/Finishes.....	5
Features	6
Optional Features	6-7
Special Function Door Closers	8
Suggested Specifications	8
Applications.....	9-12
Technical Details	13-26
Accessories.....	27-35
Parts List	36-49

OVERVIEW

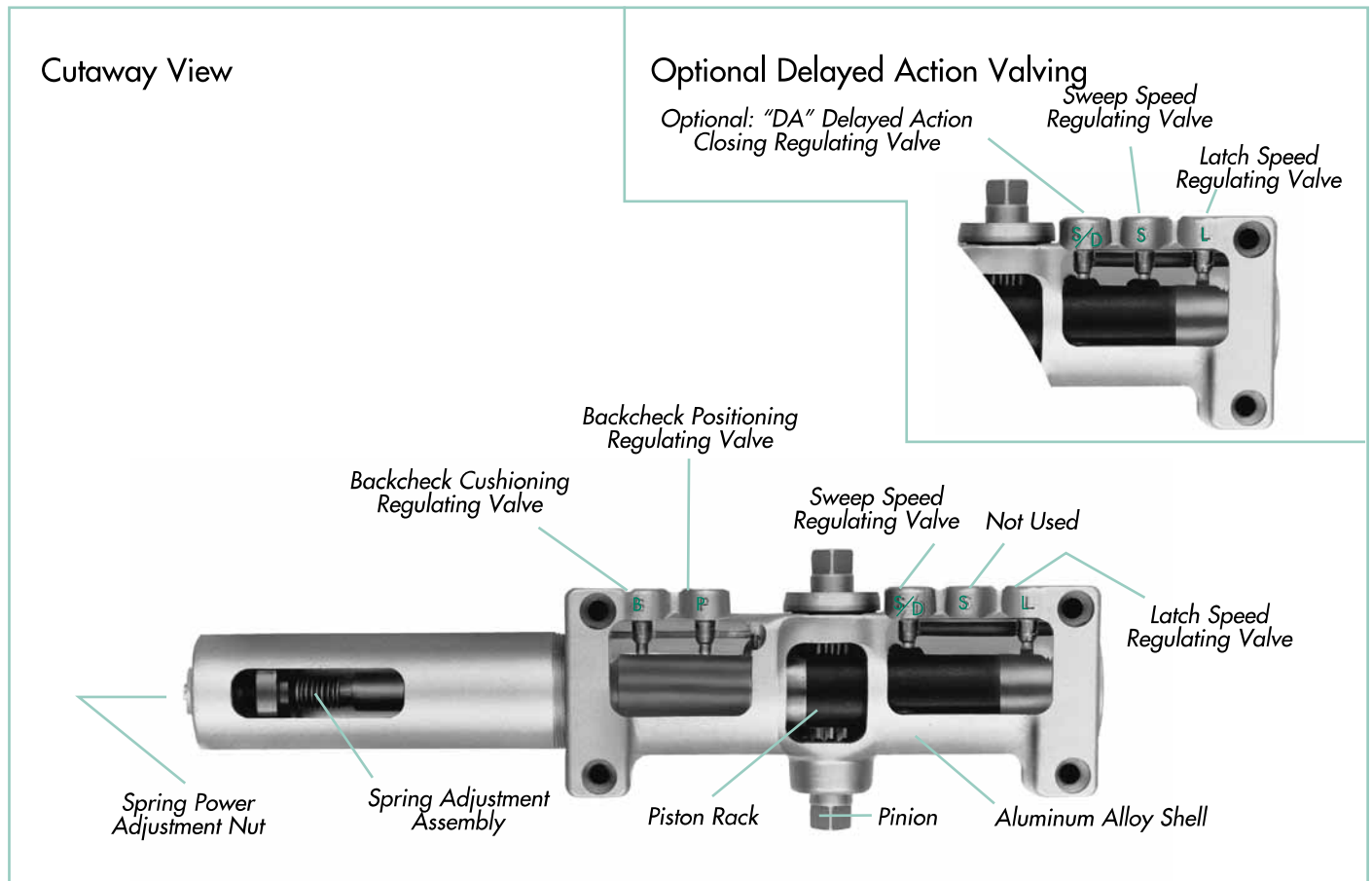

COMPLIANCE STANDARDS

- ANSI/BHMA A156.4, Grade 1 certified 
- UL / cUL listed for use on fire rated doors 
- UL10C listed for positive pressure fire test
- 7500 door closers are designed to comply with requirements for the Americans with Disabilities Act (A.D.A) and ANSI standard A117.1 
- This product is manufactured in an ISO 9001 facility



An Environmental Product Declaration (EPD) documents the cradle-to-grave life cycle of a product and how it affects the environment. An important aspect of EPD® is to provide the basis of a fair comparison of products and services by its environmental performance. EPDs can reflect the continuous environmental improvement of products and services over time and are able to communicate and add up relevant environmental information along a product's supply chain.

Windstorm

Norton 7500 door closers are UL certified for inswing and outswing single and pair (up to 8'0" x 8'0") door assemblies to ICC 500 for Storm Shelters. Additionally, the 7500 meets FEMA 361 guidelines.

7500 is part of a complete ASSA ABLOY tornado and hurricane shelter solutions utilizing Ceco StormPro 361, Curries StormPro 361, Fleming F5 doors and frames and McKinney SP hinges.

CAUTION: Door Closers for Low Opening Force Applications:

Door closers installed in openings required to meet the requirements of the Americans With Disabilities Act or ANSI/BHMA Standard A117.1, when adjusted to meet those requirements, may not provide adequate closing power to dependably close and latch the door.

HOW TO ORDER

NOTE: For optimum protection of door and frame assemblies, always use auxiliary wall, floor, or overhead door stop.

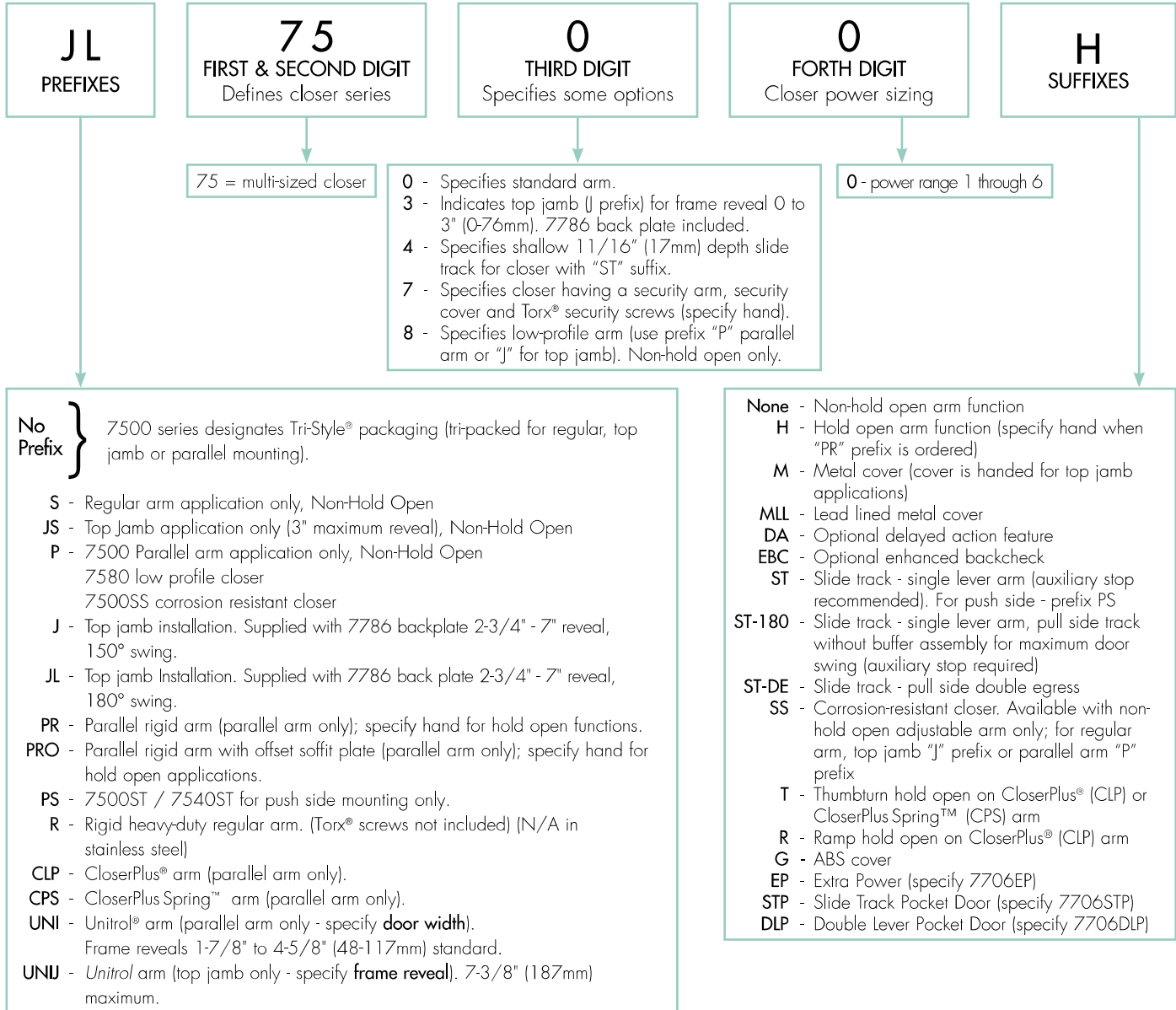

Notes:

- Door closer warranty becomes void if it is installed on the exterior side of a door in the exterior wall of a building
- It is strongly recommended, and it is required on fire door assemblies, that doors having a door closer be hung on ball-bearing or anti-friction hinges or pivots
- Failure to use the correct type and size fasteners may void factory warranty
- Fasteners for fire/smoke door assemblies must conform to NFPA 80. In some applications additional fasteners may be mandated by NFPA 80 that are not shipped with Norton's standard product, such as sleeve nuts/sex nuts or through-bolts and grommet nuts
- Sizing charts provided on pages 13-25 are based on 1-3/4" (44mm) x 7' (2.13m) standard weight doors swinging to 110 degrees. Other conditions (such as door height or weight; or wind/draft conditions) may require a larger size closer.

7500 SERIES INSTITUTIONAL DOOR CLOSER

FASTENERS

Type	Description	Arm								
		RA	PA	TJ	Low Profile	PR	CLP/CPS	UNI	UNI-J	Slide Track
DOOR										
SDST	Self Drilling Self Tapping	S	S	S	S	S	S	S	○	○
MS	Machine Screw	S	S	S	S	S	S	S	S	S
SN	Sleeve Nut/Sex Nut	○	○	○	○	S	S	S	S	S
TBGN	Thru Bolts & Grommet Nuts	○	○	○	○	○	○	○	○	○
SMS	Sheet Metal Screws	○	○	○	○	○	○	○	○	○
TORX®	Torx Drive Security Screw	○	○	○	○	○	○	○	○	○
FRAME										
SDST	Self Drilling Self Tapping	S	S	S	S	S	S	S	S	S
MS	Machine Screw	S	S	S	S	S	S	S	S	S
SMS	Sheet Metal Screws	○	○	○	○	○	○	○	○	○
TORX	Torx Drive Security Screw	○	○	○	○	○	○	○	○	○

S = standard; ○ = optional

SN are for use on unreinforced hollow metal doors or to prevent any hollow metal door from collapse/dimpling. They can also be used for thru bolting on wood doors. SN are supplied for 1-3/4" (44mm) thick doors unless specified for 2-1/4" (57mm) thick doors.

TBGN are an alternative to SN for wood doors. TBGN are supplied standard for 1-3/4" (44mm) thick doors. They can be specified for 1-3/8" (35mm) thick doors.

SMS - when specified, closer will be packed with sheet metal screws for the door AND sheet metal screws plus machine screws for the frame.

TORX screws with security pin are standard with 7570 Security Door Closers. Torx may be specified for all other series applications. Torx are only available with machine screw threads. Sheet metal screw threads are not available.

FINISHES

Norton offers waterborne acrylic, polyester powder coat and plated finishes. Custom finishes are available on special order. A sample and approval is required.

Waterborne acrylic and polyester powder coat will withstand 100 hours of salt spray (ANSI requires 25 hours).

ANSI/BHMA	Description
600*	Prime Coat
605	Bright Brass
606	Satin Brass
611	Bright Bronze
612	Satin Bronze
613E	Dark Oxidized Satin Bronze - Equivalent
619	Satin Nickel
625	Bright Chrome
626	Satin Chrome

ANSI/BHMA	Description
689	Aluminum
690	Statuary Bronze
691	Dull Bronze
693	Black
694	Medium Amber
N/A	556 White
696	Gold

* 600 is a special rust-inhibiting prime coat. Closers can be ordered prime coat only (specify closer x 600). An additional charge applies if finish coat is required over prime coat.

- Norton closer bodies and plastic covers are available in waterborne acrylic finishes. Arms and metal covers are available in powder coat or plated finishes.
- When a plated finish is ordered, arm and cover will be plated unless "cover only" is specified.

FEATURES

Aluminum Alloy Housing

Closer bodies are constructed of a special aluminum alloy, carefully selected to accommodate interactive steel components and operating conditions.

Rack & Pinion Operation

Provides a smooth constant control of the door through its full opening and closing cycle. 180° door swing can be achieved when door, frame, hardware and arm function do not interfere.

Non-handed

With few exceptions all series 7500 door closers are non-handed and can be installed on either right or left hand swing doors. Pinion shaft extends vertically through the closer body in both directions. Some options, as noted on pages 6-8, will require that the hand of the closer be specified.

Sweep Speed Control Valve

Allows adjustment of door speed from the door's full open position down to approximately 10° from the closed position.

Latch Speed Control Valve

Allows adjustment of door speed from approximately 10° down to the door's fully closed position.

Tri-Style® Packing

7500 comes with screws, brackets and soffit plates to allow for regular, top jamb, and parallel arm installations.

Adjustable Backcheck Cushion Valve

Provides control of the door in the opening cycle, beginning at approximately 75° of door opening. It slows/cushions the door opening, when the door is forcibly opened beyond its pre-adjusted limits.

Adjustable Backcheck Position Valve

Allows the door opening position, where backcheck cushioning begins, to be adjusted to a greater door angle, up to a maximum of 20° farther (approximately 95°).

Standard Molded Cover

Molded of high-impact U.L. listed material and covers the entire closer body assembly. This cover is non-handed for all applications.

Warranty

These closers carry a limited 25-year warranty against defect, and life of the building on the aluminum housing.

Closer Fluid

NorGlide® closer fluid is a specially formulated multi-viscosity hydraulic fluid that contains lubricity and anti-oxidation agents that provide optimum performance and efficiency. This fluid complements the interaction of the door closer's aluminum housing with its steel and brass components, while maintaining stable viscosity to allow the door closer to perform in temperatures ranging from extremely high to as low as -40° F.

Door Closer Power Options

Series 7500 Multi-Sized Door Closer

Adjustable through the entire power range of door closer sizes 1 through 6, as outlined in ANSI/BHMA standard A156.4.

The series 7500 also conforms to the minimum opening force requirements of the Americans with Disabilities Act (A.D.A.) and ANSI/BHMA standard A117.1 for interior doors.

OPTIONAL FEATURES

Corrosion-Resistant Door Closer

The series 7500SS door closers with molded plastic cover are available for use where corrosive conditions exist. This series is provided with brass adjustment valves, a 440 grade stainless steel pinion shaft, an all-aluminum body and bronze closer arm bushings; all other components are of 302/303 grade stainless steel. Fasteners are 8-18 stainless steel. This product is available for standard regular arm, top jamb and parallel arm, non-hold open, applications only.

Optional Metal Cover

This steel cover is non-handed for regular and parallel arm applications, but is handed for top jamb applications. Cover is available in sprayed or architectural plated finishes.



Security Cover

Supplied standard with all series 7570 door closers. This deep drawn steel cover is handed for all applications. The cover is fastened to the closer body at two points on top and to the door closer body stand-offs at two points on the bottom.

Optional ABS Cover

Consult factory for details

OPTIONAL FEATURES

Enhanced Backcheck

This feature provides adjustable backcheck intensity beginning at approximately 1.5 degrees of the door opening cycle. It is intended for use in situations where the standard backcheck beginning at approximately 75° of door opening allows too much unrestricted door travel to obtain control of the door without the fear of peripheral damage to the door closer, door, frame, hinges or pivots; or adjacent walls or structures. This feature is most frequently used in schools and detention facilities. Specify suffix EBC.

Adjustable Delayed Action Closing

An optional hydraulic feature that adds a third speed range to the closing cycle. This feature becomes effective when the door is opened and released at any point beyond 70°. The amount of time delay depends upon the combination of the angle of door release and valve adjustment. The valve can be adjusted with a 1/8" (3mm) hex key from no delay time up to maximum delay times of:

Door Opened and Released at	Approximate Time of Delay Cycle
180°	4-5 minutes
120°	2-3 minutes
90°	25-30 seconds

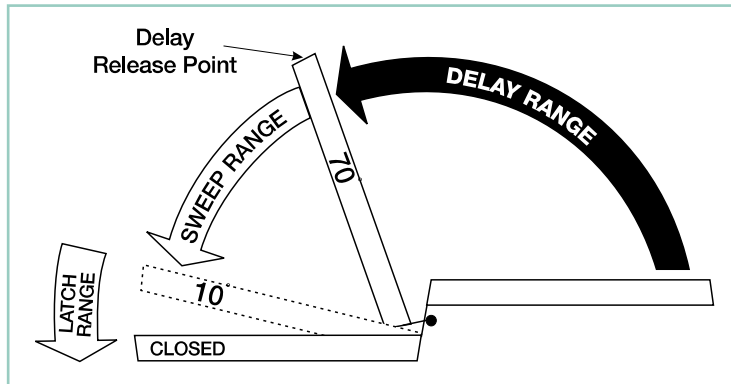

Pressure Relief Safety Valve

The delayed action hydraulic system contains a pressure relief valve. Any time the door is forced toward the closed direction while it is in the closing cycle, the valve will open and permit the door to close. This prevents damage to door, frame and closer.

Suggested Applications

Delayed Action closing allows slow-moving traffic to clear the opening before the door closer's normal closing cycle begins. This feature can be helpful in health care facilities such as hospitals and nursing homes. It provides sufficient time for persons on crutches or in wheelchairs to pass through a door without concern of it closing. At the same time, it can accommodate the facility's staff with movement of food service carts, beds, and other wheeled traffic.

Use of delayed action closers on many doors throughout industrial and commercial buildings can also assist the flow of traffic. Locations where additional time to clear the opening is advantageous are doors between office and factory/warehouse facilities, doors to workshops or laboratories, to kitchen and food processing areas, etc.

OPTIONAL FEATURES ARMS

Non-Hold Open

Self-closes door every time door is opened. Auxiliary stop (by others) required except when using the CloserPlus®, CloserPlus Spring™ or Unitrol® arms.

Hold Open

Achieved by means of friction or ball and detent/roller. Friction hold open has a range of 90° to 180° using template location and mechanical adjustment. Ball and detent or roller hold open is effective in a range of 85° to 110°.

Hold open arm door closers are not permitted to be used on fire door assemblies.

Door Opening Degrees

Arm Function	Regular Arm, Top Jamb Parallel Arm	Parallel Rigid Arm	CloserPlus® Parallel Arm	CloserPlus Spring™ Parallel Arm	Unitrol® Parallel Arm	Unitrol Top Jamb	Low Profile Regular, Parallel	Slide Track
Non-Hold Open	✓	✓	85° to 110°	85° to 110°	85° to 110°	85° to 110°	✓	85° to 110°/180°
Hold Open	90° to 180°	85° to 180°	85° to 110°	85° to 110°	85° to 110°	85° to 110°	N/A	85° to 110°

✓=180° trim and template permitting

SUGGESTED SPECIFICATIONS

7500 Series

Closers for interior and exterior doors shall be full rack-and-pinion type with cast aluminum alloy body. Closers shall be surface mounted and shall project no more than 2-3/16" (5.5mm) from the surface of the door. Closers shall be non-handed to permit installation on doors of either hand. Closer fluid shall contain lubricity and anti-oxidation agents. Closer fluid shall maintain stable viscosity to allow door closer to perform in temperatures ranging from extremely high to as low as -40°F. Closers shall have multi-size spring power adjustment to permit setting of spring from size 1 through size 6. Closers shall have two non-critical valves, hex key adjusted, to independently regulate sweep speed and latch speed. Closers shall have backcheck cushioning controlled by a hex key adjusted valve. Closers shall have backcheck position controlled by a hex key adjusted valve.

[Closers shall have adjustable delayed-action closing controlled by a hex key adjustable valve.]

[Closers shall be highly corrosion resistant and shall have all external body components of aluminum, brass or stainless steel material and all fasteners of stainless steel.]

Regular arm and top jamb closers shall have a non-hold open shoe permitting 15% (+/- 7-1/2%) power adjustment. **Closers shall be enclosed in a [molded resin cover] [plated or sprayed metal cover]. Closers to be Norton [7500] [7500M] [7500SS].

**For special arms insert the appropriate specification from column three on this page.

****Unitrol® Arm**

Door closers shall have a fixed door stop feature effective at one point selected at installation, from 85° - 110° in five-degree increments. Door stop shall be cushioned by a shock-absorbing heavy-duty spring action effective at the [soffit plate] [arm shoe] pivot. [Closers shall be provided for parallel arm installation using rigid steel main arm and secondary arm lengths proportional to the door width.] [Closers shall be provided for top jamb installation using steel, rigid main arm and telescoping secondary arm adequate for the frame reveal of the openings.]

****CloserPlus® Arm**

Door closers shall have a field reversible door stop. Hold open tension shall be adjustable effective at one point selected at installation, from 85° - 110° in five degree increments. Closers shall be provided for parallel arm installation using a forged rigid steel main arm and secondary arm.

****CloserPlus Spring™ Arm**

Door closers shall have built-in door stop [and holder] effective at one point selected at installation, from 85° - 110° in five-degree increments. Door stop mechanism shall be reversible and have a buffer spring that engages prior to the dead stop feature, reducing shock loads to the door and frame assembly. Door stop mechanism shall be attached to soffit plate. [Hold open mechanism shall have engage/disengage selection actuated by thumbturn]. Closers shall be provided for parallel installation using a forged rigid steel main arm and secondary arm.

APPLICATIONS



Non-hold open arm shown

Regular Arm

This is the only pull-side application where a double lever arm is used. It is the most power efficient application for a door closer. Sufficient frame, door and/or ceiling clearance must be considered.

Since the arm assembly projects directly out from the frame, this application may present an aesthetics issue or be prone to vandalism.



Non-hold open arm shown

Top Jamb

For efficiency reasons this application provides the best alternative to the regular arm application. There must be sufficient frame face and/or ceiling clearance for this application. It requires a top rail on the door of just 2-1/8" (54mm). This application provides the best door control for doors in exterior walls that swing out of a building.

The entire door closer and arm assembly project from the frame, similar to the regular arm application, where matters of appearance and malicious abuse can be of concern. Consideration must be given to depth of frame reveal.



Non-hold open arm shown

Parallel Arm

This application provides the most appealing design appearance for a surface-mounted door closer having a double lever arm. This also makes it beneficial in vandalism-prone areas. It is on the push side of the door and the arm assembly extends almost parallel to the door. In the closed position, there is very little or no hardware projecting beyond the frame face in most situations.

Due to the geometry of the arm it is approximately 25% less power-efficient than a regular arm application. The entire closer and arm assembly are mounted below the frame stop, requiring a top rail clearance on the door of between 6-5/8" (168mm), when using a low profile arm, to 7-1/4" (184mm), when using the hold open arm.

7500 SERIES INSTITUTIONAL DOOR CLOSER

PARALLEL ARM

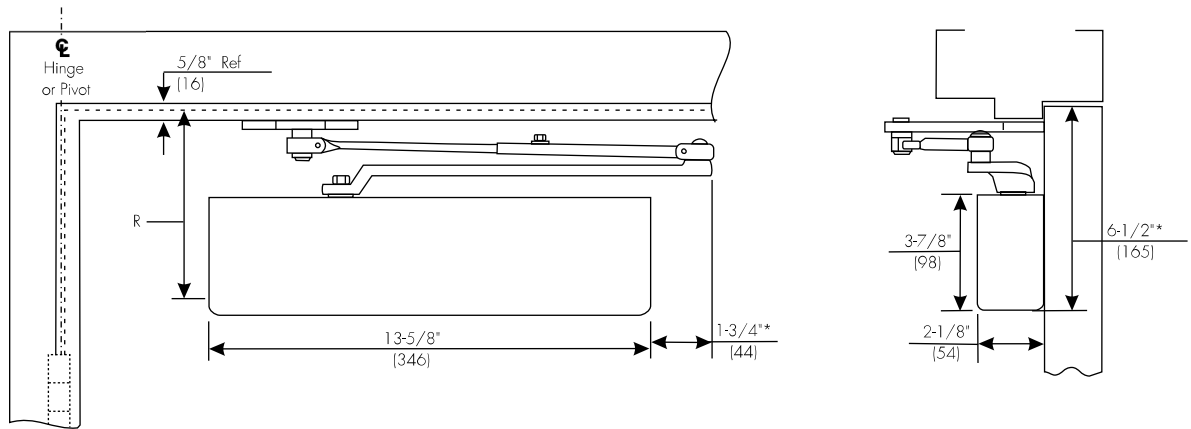

Mounting holes for closer body are spaced 2-3/8" (86mm) vertically x 6-3/4" (171 mm) horizontally.
* This dimension will vary. Standard non-hold open arm illustrated.

Maximum Door Width Inches (cm)		Model Number	
		Non-Hold Open	Hold Open
Interior	Exterior		
30" (76)	—	7500	7500H
36" (91)	30" (76)		
42" (107)	36" (91)		
48" (122)	42" (107)		
54" (137)	48" (122)		

R (inches/mm) Minimum Top Rail of Door with 5/8" (16mm) Frame Stop				
Without Drop Plate			With 7788 Drop Plate	
P7500	P7500H	P7580	P7500H	P7580
5-7/8" (149)	6-1/4" (159)	5-3/8" (137)	2-3/4" (70)	1-7/8" (48)

Note: Contact factory if door weight exceeds 250 lbs.

PARALLEL ARM

Closer Mounting Plate

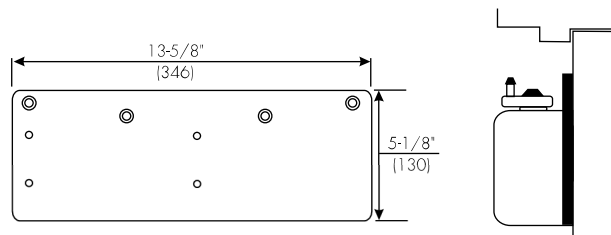

Narrow Top Rail - #7788 Drop Plate: For use where a narrow top rail prevents the closer from being mounted directly to the door surface. This drop plate can be used to mount a closer on a top rail as narrow as 2-1/2" (64mm) in height.

Brackets for Non Hold Open Arms

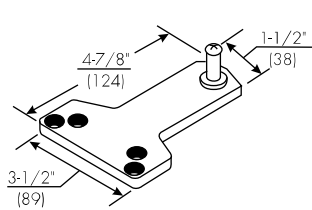

Standard Installation - #1618 Soffit Plate: Supplied standard with parallel arm closers. It can be mounted where the frame soffit is as narrow as 1" (25mm). Specify **1618A-SS** for stainless steel soffit plate.

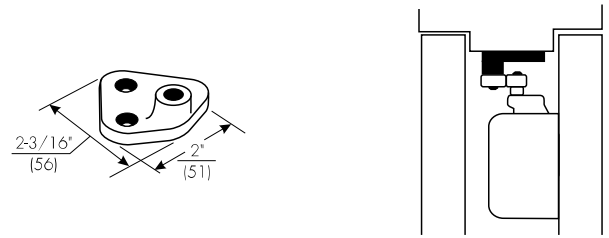

Mounting between Doors - #2018 Soffit Bracket: For use where insufficient space between companion doors does not permit use of other soffit plates. This bracket permits mounting of the closer between doors with as little as 3" (76mm) of header space. Permits closer arm to clear up to 5/8" (16mm) high stop.

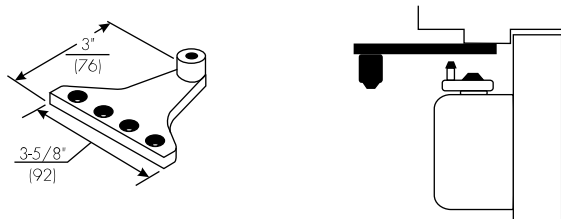

Narrow Frame/Removable Stop - #2018B Soffit Plate: For use where a narrow frame or frame with removable stop does not permit use of the standard soffit plate. This soffit plate may be mounted on the frame soffit or the frame rabbet where the stop does not exceed 5/8" (16mm) in height. All of the screw holes are in a straight line, requiring as little as 1-1/4" (32mm) of frame reveal to mount bracket and maintain good closer arm geometry. Where the frame soffit is as wide as 2" (51mm), this soffit plate may be used to clear weather-stripping that is up to 1-3/8" (35mm) wide and 5/8" (16mm) in height.

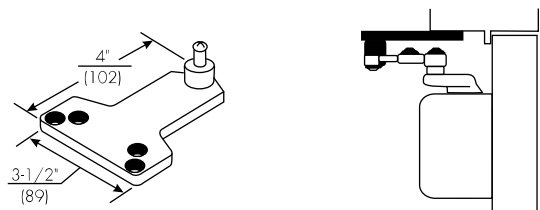

Blade/Applied Stop - #2018D Soffit Plate: For use where a blade or applied stop does not permit installation of the standard soffit plate. Mounts to either the frame soffit or rabbet. Since this soffit plate projects 7/8" (22mm) less than a standard soffit plate, it requires a minimum frame reveal of 1-1/2" (38mm). Permits closer to clear up to a 5/8" (16mm) stop.

Roton[®] Continuous Geared Hinge

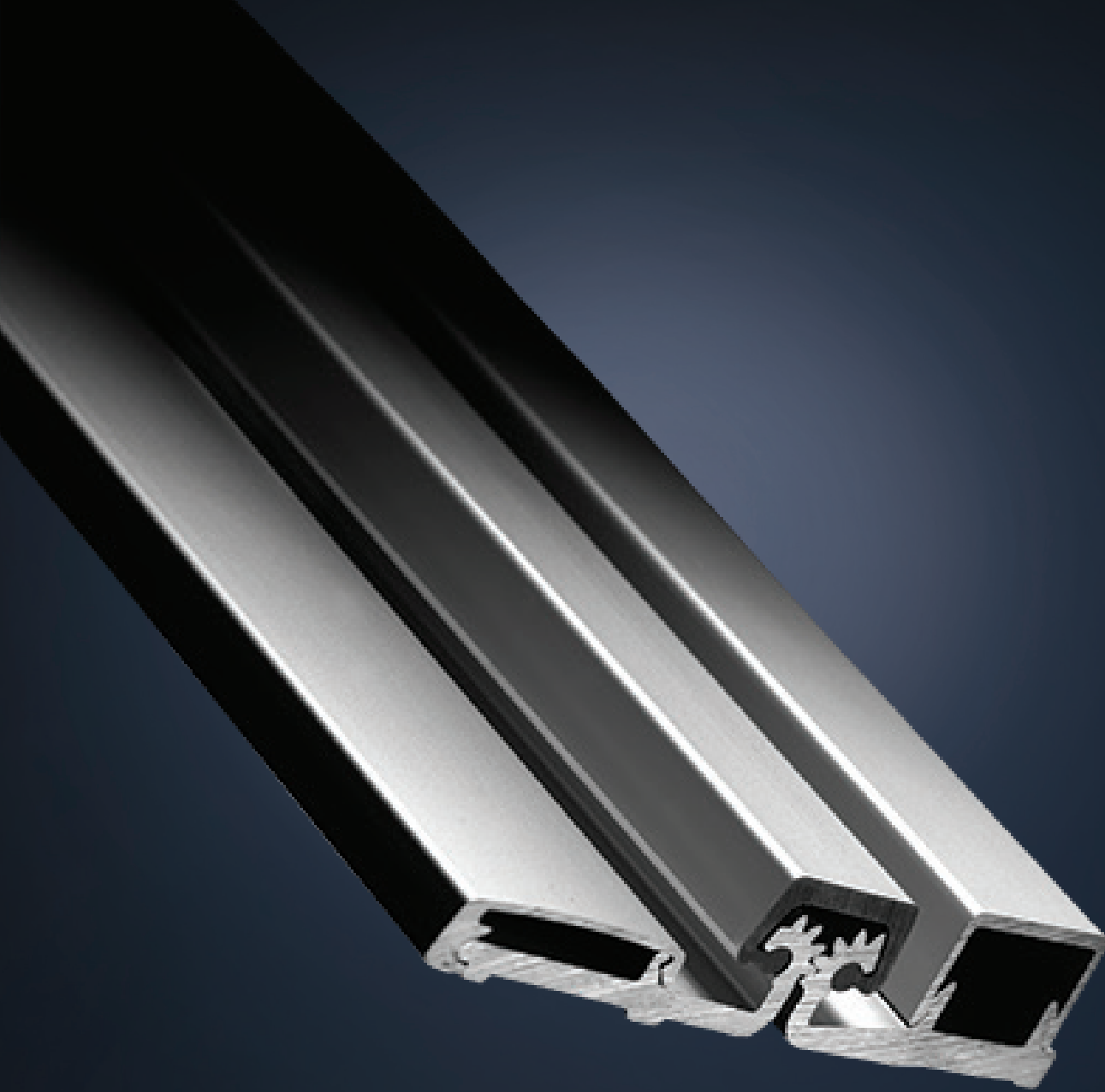

The Original. *Better.*



TRADITION

• Lifetime Warranty

Hager Companies believes in our product line and warrants our Roton® Aluminium Continuous Geared Hinges for the lifetime of the opening.

• Proudly Made in the USA

• Friction Free

Roton® Continuous Geared Aluminum Hinges are lubricated to eliminate the need for any assistance in maintaining a quiet performance.

• Fire-Rated Bearings®

To ease the ordering process of our Roton® Continuous Geared Aluminium Hinge, we provide fire-rated bearings on all hinges with no additional charge. The UL stamp denotes the hinge is fire-rated.

• Fire-Rated Up to 3-Hours

• Standard Duty, Heavy Duty, and Extra Heavy Duty Models Available

• Custom Length, Finishes, and Hole Locations Available

• Meets LEED® Requirements

The Original

Hager Companies has been manufacturing the original Roton® Continuous Geared Aluminium Hinge for over 28 years. The unique design of Roton® consists of three important parts: an internal rolling contact gear profile, a high strength cover channel, and solid bearings made of Celanex®. Working together, these parts evenly distribute door weight and maintain door alignment for superior performance.

#1 Concurrent Bearing Slots

Simultaneously milled bearing slots provide the perfect cradle for our bearings. Our improved manufacturing process precisely mills both bearing slots with consistent and measurable accuracy allowing our bearings to seat perfectly, providing smooth operation across the entire hinge for the life of the opening.

#2 Anodized In-House

Anodizing the Roton® Continuous Geared Hinge in our own facility in Montgomery, Alabama provides the consistency and flexibility needed to lead in today's market. We anodize the complete hinge including both leaves and the cover channel simultaneously, providing unmatched color consistency across the entire hinge.

#3 Straight Line Hole Pattern

Advances in manufacturing have allowed Hager to continue the tradition the Roton® Continuous Geared Hinge has provided for over 25 years. With enhanced equipment, improved tolerances and a new hole pattern we are positioned to provide the quality and lead times to meet today's market needs.

Finishes

Clear



Dark Bronze



Gold



Black



Custom colors available.

For a complete list of finish options, go to page 2 in our 2016 Roton® Catalog.

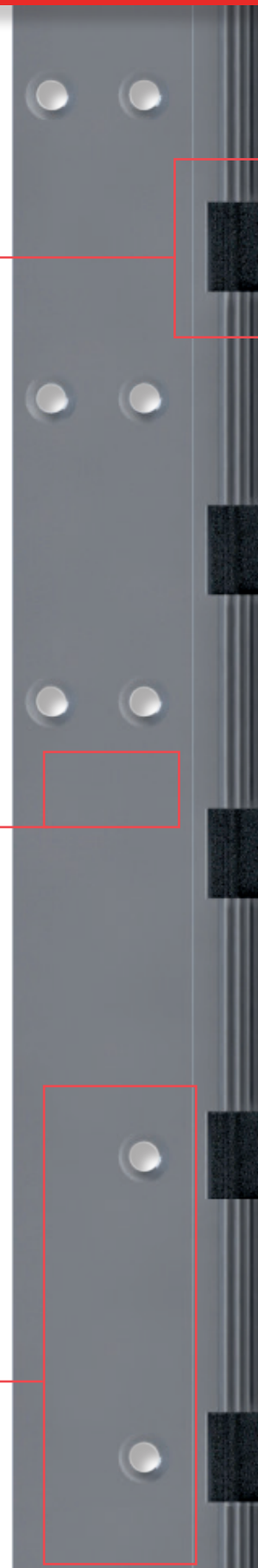

Hinge Modifications and Options

Concealed Electric Through-Wire and Monitoring

This combines continuous electric conductors and a miniature switch to provide both power transfer and monitoring.
Also available on Full Surface models.

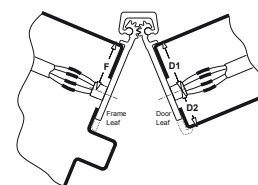

Exposed Electric Switches

Miniature push button switch is incorporated in the hinge frame leaf to monitor position of the door.

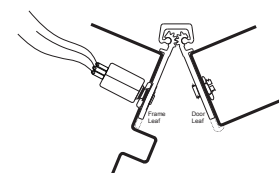

Concealed Electric Monitoring

Miniature switch is incorporated into the frame leaf.

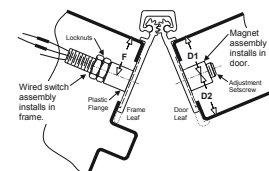

EPT 2 or EPT 10 Electric Power Transfer Preparation

Hinge leaf cutout to accommodate power transfer device.



Removable Electric Through-Wire

Transfers power discreetly from building to door hardware.
Also available on Full Surface models.



Bearing at Top

This application allows for the bearing to be set at the very top of the cover channel. The cover channel is flush with the top of the geared hinge, preventing any obstructions or debris to be inserted in the top channel.

Hospital Tip

These are ideal for use in hospitals and correctional facilities to help provide a clean and safe environment. Please consult your local representative or customer service department for available models.

Tamper Resistant Hinge

This application is intended for use in hospital psychiatric areas and places of high security. The hinge is prepared with a hospital tip (concealed models only) and every other bearing is supplied with a set screw to lock against the inside of the cover channel for additional security.

Dutch Door Hinges

Hager Companies will prepare any of our hinge models for a dutch door application. The frame leaf is furnished as a continuous extrusion and the door leaf is cut to fit the dutch door height specified. Hanging, overall net door height, amount of clearance between the top and bottom doors, their individual heights and door and frame materials should be clearly specified.

Process for Choosing the Correct Roton® Model

Determine	Select
Door and frame application (flush door and frame, inset door, door thickness, door height, etc.)	Roton® model
Frequency of door cycling and weight of door	Light, standard, heavy or extra heavy duty, lead lined
Door and frame material	Fasteners
Door opening finish	Roton® finish
Fire rating requirements, if needed	With stud or without stud

Concealed

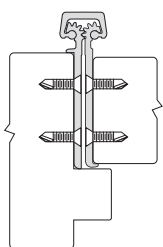

Full Surface

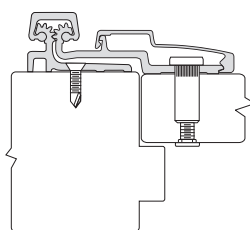

Half Surface

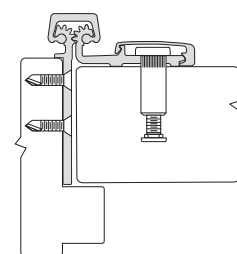

Frequency	Load
Low frequency interior doors	20 lbs. per bearing
Low frequency, very heavy doors (lead lined x-ray doors, ballistics doors, high security doors) with double rows of fasteners	30 lbs. per bearing
Medium frequency interior doors	15 lbs. per bearing
Medium frequency exterior doors	10 lbs. per bearing
High frequency exterior doors	7.5 lbs. per bearing
Very high frequency doors	5 lbs. per bearing

Roton Continuous Hinges

Hager's Roton® Continuous Geared Hinges provide superior performance you can rely on in high-traffic areas. Our Roton® hinges use unique gears designed to minimize lateral wear on the hinges while evenly distributing door weight along the full length of the frame. Roton® hinges are ideal for new construction and retrofit applications and are offered in light, standard and heavy duty weights as well as full surface, half surface and concealed.

780-112 HD

780-112 HD



SPECIFICATIONS

Applications

- Lead lined model for hospital x-ray room doors with double row of fasteners to straddle lead (specify "LL")
- Frame and door leaf alignment ribs for proper hinge and door location

Clearance

- 5/16" (8 mm) hinge side
- Plus standard lockside clearance

Door Reinforcement

None required to 200 lbs. Heavier weight use 16-gauge channel.

Electric Modifications

- Power Transfer Preparation (EPT 2) or (EPT 10),
- Exposed Electric Contacts (E),
- Exposed Electric Switches (EIS),
- Electric Through-Wire (ETW),
- Electric Monitoring (EMN),
- Electric Through-Wire and Monitoring (ETM),
- Removable Electric Through-Wire (RETW)

Fasteners

- Standard: Dril-Kwik® - #12-24 X 11/16" Flat Head Screws
- Optional: 1/2 Dril-Kwik® Screws, 1/2 wood Screws
- Additional Options Available upon request

Features

- Standard duty for medium frequency doors. **Heavy duty** for high frequency doors or heavy, medium frequency doors.
- Lead lined model for hospital x-ray room doors with double row of fasteners to straddle lead (Specify "LL")
- Frame and door leaf alignment ribs for proper hinge and door location

Finishes

CLR, DBZ, BLK

Fire Rating

Up to 3-hour metal and 90 minute wood composite (with studs)

Frame Reinforcement

None required to 200 lbs. Heavier weight use 16-gauge channel.

Length

79", **83"**, 85", 95", 119"

Length Options

Standard and Custom

Material

Aluminum 6063-T6

Notes

EPD: Roton Continuous Hinges Environmental Product Declaration, Must Order Case Quantity

Options

- Hospital Tip
- TIPIT® (see Roton accessories)

Product Description

- Concealed Leaf
- Case Pack w/ Drill Quick fasteners

Warranty

All Roton products have a lifetime warranty. When ordering electric Roton, the electric portion of the hinge has a one-year warranty.

SADDLE THRESHOLDS

- To use a saddle threshold in an offset condition, use an elevator (see page 131)

173_

AVAILABLE FINISHES: **10BE, A, BSP, D, WSP**
ANSI (aluminum): **J32300, J32330**

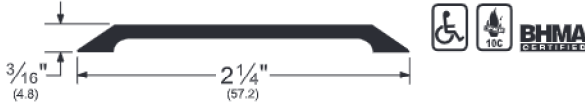

151_

AVAILABLE FINISHES: **10BE, A, BSP, D, WSP**
ANSI (aluminum): **J32300, J32330**



270_

AVAILABLE FINISHES: **10BE, A, B, BSP, D, G, WSP**
ANSI (aluminum): **J32100, J32130**
ANSI (brass): **J12300, J12330**



271_

AVAILABLE FINISHES: **10BE, A, B, BSP, D, G, SN, WSP**
ANSI (aluminum): **J32100, J32130**
ANSI (brass): **J12100, J12130**



272_

AVAILABLE FINISHES: **10BE, A, B, BSP, D, G, WSP**
ANSI (aluminum): **J32100, J32130**
ANSI (brass): **J12100, J12130**



NOTE: Products shown in this section may not be drawn to scale.

AVAILABLE FINISHES FOR PRODUCTS SHOWN ON THIS PAGE

10BE (Satin Bronze Powder Coated Aluminum) **A** (Mill Finish Aluminum) **B** (Mill Finish Extruded Bronze [Brass])
BSP (Black Suede Powder Coated Aluminum) **D** (Dark Bronze Anodized) **G** (Gold Anodized)
SN (Satin Nickel Anodized) **WSP** (White Suede Powder Coated Aluminum)

NOTE: **G, SN** are available with limited inventory

PEMKO
ASSA ABLOY

Experience a safer
and more open world

800-824-3018 | www.pemko.com
Check the web site for the up-to-date catalog

Copyright © 2015-2025, ASSA ABLOY Accessories and Door Controls Group, Inc., an ASSA ABLOY Group company. All rights reserved.
Reproduction in whole or in part without the express written permission of ASSA ABLOY Accessories and Door Controls Group, Inc. is prohibited.

ACCENTRA®

ASSA ABLOY













Experience a safer
and more open world

7000 SERIES

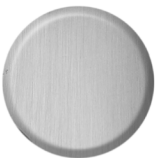
Architectural Exit Devices



FINISHES

ANSI/BHMA Code Finish Description				
605 Bright Brass, Clear Coated	606 Satin Brass, Clear Coated	611 Bright Bronze, Clear Coated	612 Satin Bronze, Clear Coated	613E Dark Oxidized Satin Bronze - equivalent
				
619* Satin Nickel Plated, Clear Coated	625 Bright Chrome Plated (540F trim only)	626* Satin Chrome Plated (Trim only)	629 Bright Stainless Steel	630* Satin Stainless Steel
				
693 Black Painted	BSP Black Suede Powder Coat	WSP White Suede Powder Coat		
				

613, 626 and 722 finishes available as Special Product Requests only. Please contact Customer Service for more information.

*Finish available with MicroShield® antimicrobial coating, additional finishes by special application. Consult factory for availability.

MicroShield coating may vary finish color from architectural standards. MicroShield is not intended as a substitute for traditional infection control programs such as hand hygiene or use of disinfectants. Coated products must still be cleaned to ensure the surfaces will be free of destructive microbes. ASSA ABLOY ACCENTRA® makes no representations or warranties, express or implied, as to the efficacy of MicroShield.

Finishes For Touchbar Covers Only

ANSI/BHMA Code	Finish Description
LUM	Lumi-lite Photoluminescence
SS	Stainless Steel

Lumi-Lite

Lumi-lite uses photoluminescence technology to provide visibility of exit doors in low-light, no light or smoky conditions. Lumi-lite can be ordered with your 7000 Series Exit Device or easily retrofitted to existing devices. See Lumi-lite Touchpad Cover on page 57 for more information.



HOW TO ORDER

From this outline select the Model Number for the ASSA ABLOY ACCENTRA® 7000 Exit Device Series you require.

7	X	X	X	Mechanical/Electrical	Size	Design	Trim	Finish	Other Info.
	Second Digit: "1" - Standard device, 4-1/2" (114mm) or wider door stile. "2" - Narrow stile door or narrow escutcheon trim (500F, 510F Series)	Third Digit: "0" - Rim Device, Pullman Latch "1" - SVR Device up to 8' "2" - CVR Device, Metal Doors up to 8' "3" - Mortise Device "5" - SquareBolt® Rim Security "6" - CVR Device over 8', wood door or LBR "7" - SVR Device over 8' or LBR	Fourth Digit: "0" - Standard "5" - Cylinder Dogging (Not with suffix "F")	Mechanical Feature  "F" - Fire Exit Device "M" - Narrow escutcheon trim in 4-1/2" (114mm) or wider door stile "LBR" - Less Bottom Rod ² "L5" - Mortise Device, Entry by Key with/without Rigid Lever ¹ "L8" - Mortise Device, Entry by Lever "T5" - Mortise Device with Thumbpiece Trim "T8" - Mortise Device, Active Thumbpiece Trim "2" - Double Cylinder Device ³ "WS" - Windstorm Certified Products ^{5,6,7} 5CH - 5LB pressure release ^{8,9} Electrical Feature "A" - Alarm Kit "B" - Bar Monitor or Signaling "D" - Delayed Egress "O" - Outside Trim Monitor or Signaling "MELR" - Motorized Electric Latch Retraction "S" - Latchbolt Status Monitor or Signaling "Safe" - Mortise Device Trim Control (lever only) "Secure" - Mortise Device Trim Control (lever only)	Size: DOW = Door Opening Width "24" 24" DOW "36" 30" to 36" DOW "48" 36" to 48" DOW Door Height: 7- = 7' standard -8 = 8' (2.44m) -9 = 9' (2.74m) -10 = 10' (3.05m)	Trim Design (Lever only) see pages 22-23	Trim Model Number see pages 24 - 30	See page 5	Other Information: Door Hand - RHR or LHR Door Thickness Specify if over 1-3/4" (45mm) Fastener Options - TORX® Security Screws SNB (wood, composite, or unreinforced metal doors) see pages 56 - 58

Ordering Examples

Exit Device Only

7150D-36 x 619 x RHR x SNB

Exit Device with Trim and Cylinder

7170F90-10 x 48 x AU626F x 605 x LHR x 1109 GA 0-bit

Trim Only

M0656F x 630 x RHR x LC

Double Cylinder Exit Device with Trim

7150F-2-36 x AU626F x 630

It is recommended that exit devices and trim for the same opening be ordered together. Standard product is for 1-3/4" (44mm) reinforced metal doors. Accessories detached from the device and trim should be specified separately. Materials by others are required to be fit for the purpose as detailed in this catalog and the product installation literature.

Notes:

1. Required for electrical feature, Suffix "SAFE" or "SECURE".
2. LBR available on 7160(F90) and 7170(F90) devices only.
3. For double cylinder devices, suffix "2" after fourth digit.
4. If "24" device is to be used with a DOW greater than 24", the device will ship without UL label. The 12" touchpad will not cover 50% of the device touchbar length.
5. "WS" applies only to 7150(F), 7250M(F) and 7170(F) devices.
6. Maximum opening size 8'0" x 8'0".
7. Contact Ceco, Curries® or Fleming for detailed frame/door requirements and limitations.
8. 5CH applies only to 7100 devices.
9. The 7100 Rim Exit Device with the 5CH option is not compatible with the MELR option.

7150(F) RIM SQUAREBOLT®

Just as easy to open as traditional latchbolts, the SquareBolt® exit device's unique construction offers innovative protection. Its SquareBolt design presents an improved physical barrier over standard rim latchbolts. The SquareBolt exit device locks into place and stays there. Credit cards, crowbars, door rattling and shaking are resisted, significantly reducing the threat of unauthorized entry.

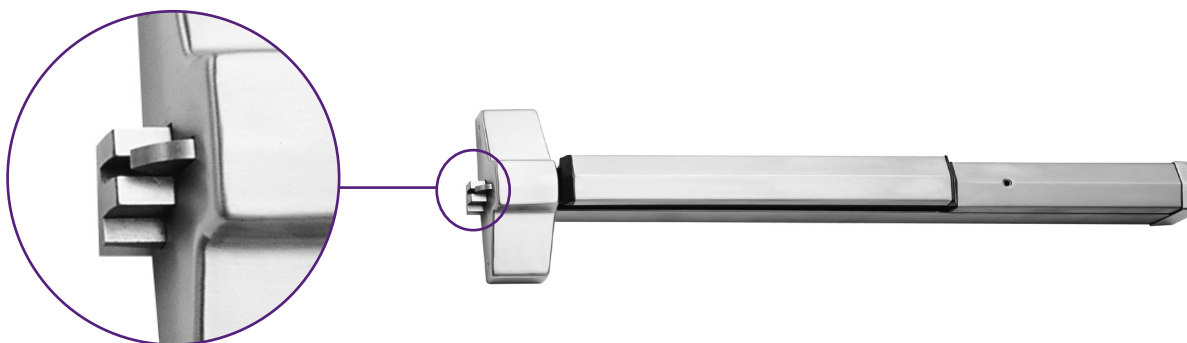

Features

- SquareBolt security deadbolt designed for maximum holding power
- Non-handed for easy installation
- Can be retrofitted onto existing 7100 series templated doors
- Fully adjustable surface-mounted 3/8" diameter roller strike complete with positive locking plate and shims
- Available in double cylinder function (handing must be specified)
- Available certified hurricane resistant (refer to local codes). Specify 7150(F)WS  Hurricane

Applications

- Single swing doors
- Pairs of doors with removable mullions
- Metal, wood or composite door materials

Specifications

Door Opening Width	-24 for 24" (60cm) doors -36 for 30" - 36" (76cm - 91cm) doors -48 for 36" - 48" (91cm - 122cm) doors Optional sizes can be special ordered. Consult Technical Product Support.
Door Thickness	1-3/4" (44mm) standard. Optional door thicknesses available to 3-1/2"; specify door thickness when ordering.
Minimum Stile Width	4-1/2" (114mm)
Projection	3-1/4" (83mm) active, 2-3/4" (70mm) dogged
Deadbolt	1" (25mm) slide projection bolt with full 3/4" (19mm) projection
Strike	757F, 793 optional (double door application, panic only)
Fasteners	Machine screws and wood door fasteners standard for panic hardware. Sex nuts and bolts supplied standard for fire exit hardware.
Trims	620F series escutcheon trim, 630F series pull/thumbpiece trim, 680F series offset pull trim, 540F series rose trim, 121NL cylinder only. See pages 22-24.
ANSI/BHMA	A156.3, Type 4 or 28, Grade 1
UL/cUL	FVSR/FVSR7 - Panic hardware; GXHX/GXHX7 - Fire exit hardware (F) (4' x 8' single, 8' x 8' pairs, 3 hr.); ZHEM - Latching hardware; ZHLA - Windstorm rated assemblies
Dogging	Hex key dogging supplied standard on panic devices
Options	Cylinder dogging, shim kit #723, sex nuts and bolts, MicroShield®, Lumi-lite
Warranty	5-year limited

CYLINDERS

Rim

The following chart details rim cylinders for use with 480F, 500F, 510F, 620F, 680F, 630F, 121NL trims and outside of SDA16 door alarm:

				Collar Requirements*				
				480F/500F/510F	620F/680F	630F	121NL	SDA16 Outside
Model #	Description	Pins	Length					
1109	Standard Fixed Core	6	1-1/4"	599.419	No Collar	No Collar	1765.250	1765.250
1109	Standard Fixed Core	7	1-7/16"			KP4		
1709	CMK	6	1-15/16"	599.544	1765.250	1765.250		
1709	CMK	7	1-5/8"			1765.406		
1193	LFIC Complete	6	1-7/16"	599.544		1765.250		
1193	LFIC Complete	7	1-5/8"	599.700	1765.344	1765.406		
5109	Security Fixed Core	6	1-9/16"	599.419	No Collar	1765.250		
5109	Security Fixed Core	7	1-7/16"					
U5109	High Security Fixed Core	6	1"	NA	No Collar	No Collar	No Collar	No Collar
U5109	High Security Fixed Core	7	1"					
5193	Security LFIC Complete	6	1-7/16"	599.544	1765.250	1765.250	1765.250	1765.250
5193	Security LFIC Complete	7	1-5/8"	599.700	1765.344	1765.406		
K300	ASSA ABLOY ACCENTRA™ KeyMark® Standard Fixed Core	6	1-1/8"	599.544	KP4	1765.250		
K300	ASSA ABLOY ACCENTRA™ KeyMark® Standard Fixed Core	7						
K840/ K880	ASSA ABLOY ACCENTRA™ KeyMark® LFIC Complete / Housing Only	6	1-7/16"	599.700	1765.406	1765.500		
K840/ K880	ASSA ABLOY ACCENTRA™ KeyMark® LFIC Complete / Housing Only	7	1-5/8"	NA	1765.563	1765.719		
K640/ K680	ASSA ABLOY ACCENTRA™ KeyMark® SFIC Complete / Housing Only	6	1-1/4"	599.544	KP4	1765.250		
K640/ K680	ASSA ABLOY ACCENTRA™ KeyMark® SFIC Complete / Housing Only	6 or 7	1-3/8"	599.700	1765.187	1765.406		
A640/ K680	Best® Keyway SFIC Complete / Housing Only	6	1-1/4"	599.544	KP4	1765.250		
A640/ K680	Best® Keyway SFIC Complete / Housing Only	6 or 7	1-3/8"	599.700	1765.187	1765.406		
2109	Schlage® "C" Keyway Fixed Core Available 0-bitted or keyed random.	6	1-1/8"	599.419	No Collar	No Collar		

*Based on 1-3/4" door thickness. Collar length required must be specified for cylinders and/or housings ordered separately.

LFIC = Large Format Interchangeable Core

SFIC = Small Format Interchangeable Core

NA = Application Not Available

CYLINDERS

Mortise

The following chart details mortise cylinders for use with 350F, 650F, 660F, 670F trims, cylinder dogging, delayed egress, and 7116 alarms:

				350F/650F		660F/670F		Cylinder Dogging/ DEED/7116	
				Cam	Collar	Cam	Collar	Cam	Collar
Model #	Description	Pins	Length	Cam	Collar	Cam	Collar	Cam	Collar
2153	Standard Fixed Core	6	1-1/8	2160	NA	2160	NA	2160	No Collar
		6	1-3/4		No Collar		KP4		NA
		7	1-1/4		NA		NA		1765.156
		7	1-3/4		No Collar		KP4		NA
2196	LFIC Complete	6	1-1/2		NA		NA		1765.406
		6	1-3/4		No Collar		KP4		NA
2197	LFIC Complete	7	1-11/16		KP4		1765.250		1765.594
5153	Security Fixed Core	6	1-1/8		NA		NA		No Collar
		7	1-1/4		NA		NA		1765.156
U5153	High Security Fixed Core	6	1-1/8		NA		NA		NA
		7	1-1/4		NA		NA		1765.406
5196	Security LFIC Complete	6	1-1/2		NA		NA		1765.406
		6	1-3/4	No Collar	KP4	NA			
5197	Security LFIC Complete	7	1-11/16	KP4	1765.250	1765.594			
K100	ASSA ABLOY ACCENTRA™ KeyMark® Standard Fixed Core	6 or 7	1-1/8	KC1	NA	KC1	NA	KC1	No Collar
			1-3/4		No Collar		KP4		NA
			1-3/4	Riveted	KP4	Riveted	1765.375	NA	NA
K820/K860	ASSA ABLOY ACCENTRA™ KeyMark® LFIC Complete/ Housing Only	6 or 7	1-3/4	KC1	No Collar	KC1	KP4	KC1	1765.406
		7	1-11/16		KP4		1765.375		1765.594
K620/K660	ASSA ABLOY ACCENTRA™ KeyMark® SFIC Complete/ Housing Only	6	1-1/4		NA		NA		1765.156
		6 or 7	1-3/8	No Collar	1765.281				
		6	1-3/4	Riveted	KP4	Riveted	1765.375	NA	NA
A620/K660	Best Keyway SFIC Complete/ Housing Only	6	1-1/4	KC1	NA	KC1	NA	KC1	1765.156
		6 or 7	1-3/8		No Collar		1765.281		
		6	1-3/4	Riveted	KP4	Riveted	1765.375	NA	NA
2553	Schlage® "C" Keyway Fixed Core. Available 0-bitted or keyed random.	6	1-1/8	2160	NA	2160	NA	2160	No Collar

NA = Application Not Available

MULLION CYLINDER KIT AND OPTIONS

M200(F), SM and KRM Options

- **M203 Spacer Block**

Recommended for double rabbeted frames where the stop face width is less than the mounting hole spacing or for applications with 5-3/4" (146mm) or less door frames.

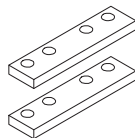

- **M204 Angle Bracket**

Recommended for any header configuration with less than 3" (76mm) of mounting surface.

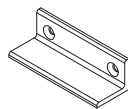

Mullion Cylinder Kit	Available with the following mullions series
AMCK1	KRM200
	KRM200F
	KRM200SM
AMCK2	KRM200FWS

Note: Mullion cylinder kit contains washer, collar and cylinder

*Specify finishes and cylinder keyed code when ordering

EX: AMCK1 X FINISH X CYLINDER KEYED CODE
(i.e. AMCK1 X 630 X CT6)

Keyed Codes	Description
CT6	LFIC Complete, 6 Pin
CT6LL	ASSA ABLOY ACCENTRA™ KeyMark® LFIC w/Temp LFIC, 6 Pin
CT6SD	ASSA ABLOY ACCENTRA™ KeyMark® SFIC w/Temp Disposable SFIC, 6 Pin
CT6SL	ASSA ABLOY ACCENTRA™ KeyMark® SFIC w/Temp Lockable SFIC, 6 Pin
CT7	LFIC Complete, 7 Pin
CT7LL	ASSA ABLOY ACCENTRA™ KeyMark® LFIC w/Temp LFIC, 7 Pin
CT7SD	ASSA ABLOY ACCENTRA™ KeyMark® SFIC w/Temp Disposable SFIC, 7 Pin
CT7SL	ASSA ABLOY ACCENTRA™ KeyMark® SFIC w/Temp Lockable SFIC, 7 Pin
CY	Standard Fixed Core
ICLC	LFIC, Less Core
KM	ASSA ABLOY ACCENTRA™ KeyMark® Standard Fixed Core
KMLIC	ASSA ABLOY ACCENTRA™ KeyMark® LFIC Complete
KMLICH	ASSA ABLOY ACCENTRA™ KeyMark® LFIC Housing Only
KMSIC	ASSA ABLOY ACCENTRA™ KeyMark® SFIC Complete
KMSICH	ASSA ABLOY ACCENTRA™ KeyMark® SFIC Housing Only
S	Security Fixed Core
SC	Schlage® "C" Keyway Fixed Core
SFIC	Best® Keyways SFIC Complete
SFICLC	Best® Keyway SFIC Housing Only
SIC	Security LFIC Complete

7100 SERIES TRIMS

620F and 650F Series Escutcheon Trim



- Certified ANSI/BHMA A156.3, Grade 1.
- Trim thrubolts to exit device for strength.
- Beveled sides improve attack resistance.
- Solid forged escutcheon and Free-Wheeling trim resists vandalism and abuse.
- Flush cylinder in 6-pin applications for additional security.
- 1-3/4" (44mm) door standard. For doors through 2-1/4" (57mm) or shim-mounted devices, specify on order.
- Dimensions: 3" x 10-1/4" x 13/16" (76mm x 260mm x 19mm).
- Cylinders not included. See page 45-48 for cylinder options. 1-1/2" mortise cylinder required for mortise trim.
- Available with AR, AU, CR, JN, MO, PB, PN, VI and HA lever designs. See page 22.
 - Finishes: 605, 606, 611, 612, 613E, 619, 626, 629, 630, 693, BSP, WSP
- Available with Reflections® lever designs. See page 23.
 - Finishes: 605, 606, 611, 612, 613E, 619, 626, 629, 630, BSP, WSP
- Trim ordering example: AU626F x 626 x RHR.
- 5-year limited warranty.

Application	Cylinder	Classroom/ Storeroom Cylinder Controls Thumbturn	Exit Only Blank Plate	Nightlatch Access by Key	Classroom Cylinder Controls Lever	Storeroom Cylinder Controls Lever	Nightlatch Cylinder by Lever	Passage	Dummy Trim Free- Wheeling	Dummy Rigid Lever
7100(F) 7150(F) 7110(F) 7120(F) 7160(F) 7170(F)	Rim	603F ¹	620F	621F ²	626F	626F ¹	627F ²	628F	628F ¹	629F
7130(F)	Mortise	—	620F	651F	656F	—	656F	658F	—	658F
7100(F)-2 7150(F)-2	Rim x Rim	—	—	—	626F	—	—	—	—	—
7130(F)-2	Mortise x Rim	—	—	—	656F	—	—	—	—	—
ANSI		11/12	01	03	08	09	03	14	02	02

1. 09, 12 and Free Wheeling 02 achieved with single trim modification at installation.

2. Not recommended for use with vertical rod devices.

3. 08 only

For 626, 629 & 630 finishes the escutcheon is plated to simulate stainless steel.

For 629 & 630 finishes the standard levers are plated to simulate stainless steel.

Free-Wheeling is not available on mortise trim.

For 620F series trim, optional door thickness available up to 3-1/2", specify on order.

Door stops, holders and silencers

Floor stops and holders

FS18S/FS18L

Floor stop

- FS18S - 1 1/2", FS18L - 3 1/2"
- Security door stops designed for use in high vandalism areas
- Molded from black flame resistant, resilient material around a heavy-duty stud
- Once grouted in concrete, leaves no exposed fasteners to be tampered with or removed
- Ideal for jail or security cell areas where floor mounted stops are required
- FS18L also ideal for concrete wall applications

Specifications

Material substrate Made from rubber

Finishes

- Black rubber

Dimensions - FS18S

Height	Diameter	Stud length
1 1/2"	2"	2 1/2"

Dimensions - FS18L

Height	Diameter	Stud length
3 1/2"	2"	2 1/2"



FS18S

FS18L

FS434

Floor stop

- For undercut doors up to 1 1/2"
- Packed with fasteners for light duty masonry and wood applications
- Soft, resilient black rubber

Specifications

Material substrate Made from wrought steel

Dimensions

Overall height	Base size
2 5/8"	1 1/2" W x 2 3/4" L

Finish

BHMA	Description	Substrate	Finish
604	Zinc Plated	Steel	US2C

Available accessories

- Replaceable soft, resilient black rubber



430

Floor door stop

- For undercut doors up to 1 1/2"
- Welded wood screws for wood applications
- White rubber tip

Specifications

Material substrate Made from cast brass and aluminum

Dimensions

Overall height	Base size
2 5/8"	1 1/2" W x 2 3/4" L

Finishes - brass

BHMA	Description	Substrate	Finish
605	Bright Brass	Brass	US3
606	Satin Brass	Brass	US4
609	Blackened Brass	Brass	US5
613	Oil Rubbed Bronze	Brass	US10B
619	Satin Nickel	Brass	US15
625	Bright Chrome	Brass	US26
626	Satin Chrome	Brass	US26D

Finishes - aluminum

BHMA	Description	Substrate	Finish
666	Bright Brass	Aluminum	A3
-	Blackened Brass	Aluminum	A5
669	Bright Nickel	Aluminum	A14
673	Aluminum Clear Coat	Aluminum	A92

For other colors, consult factory.

Available accessories

- Replaceable white or black rubber tips



DOOR BOTTOM SWEEPS

315_N

AVAILABLE FINISHES: **B, BSP, C, D, WSP, 10BE, G, SN**
 REPLACEMENT INSERT: **E315 (BL)**
 ANSI: **R3B434, R3B435**

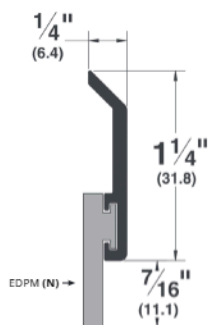

3151_N

AVAILABLE FINISHES: **BSP, C, D, G, WSP**
 REPLACEMENT INSERT: **E321 (BL)**
 ANSI: **R3B434**

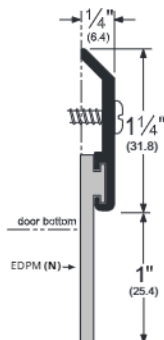

321_N

AVAILABLE FINISHES: **BSP, C, D, G, WSP**
 REPLACEMENT INSERT: **E321 (BL)**
 ANSI: **R3B434, R3B435**

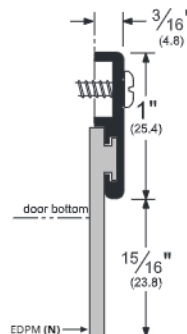

368_N

AVAILABLE FINISHES: **BSP, C, WSP**
 REPLACEMENT INSERT: **E368 (BL)**
 ANSI: **R3B434, R3B435**

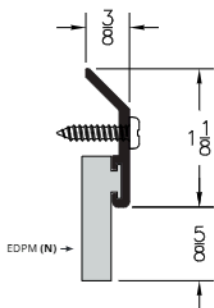

NOTE: Products shown in this section may not be drawn to scale.

AVAILABLE FINISHES FOR PRODUCTS SHOWN ON THIS PAGE

B (Mill Finish Extruded Bronze [Brass]) **BSP** (Black Suede Powder Coated Aluminum)
C (Clear Anodized) **D** (Dark Bronze Anodized) **G** (Gold Anodized) **WSP** (White Suede Powder Coated Aluminum)

800-824-3018 | www.pemko.com

Check the web site for the up-to-date catalog

Copyright © 2015-2025, ASSA ABLOY Accessories and Door Controls Group, Inc., an ASSA ABLOY Group company. All rights reserved. Reproduction in whole or in part without the express written permission of ASSA ABLOY Accessories and Door Controls Group, Inc. is prohibited.

PEMKO
ASSA ABLOY

Experience a safer
 and more open world

190, 350 AND 500 STANDARD ENTRANCES



Single-Source Packages Generate Versatile First Impressions



Curtis Culwell Center
Garland, Texas
ARCHITECT
HKS, Inc., Dallas, Texas
GLAZING CONTRACTOR
B & B Glass, Inc., Dallas, Texas
PHOTOGRAPHER
© Blake Marvin – HKS

Tough yet attractive, Kawneer's Standard Entrances are designed as a single-source package of door, door frame and hardware that is easily adaptable to custom requirements. Designed to complement new or remodel construction as well as modern or traditional architecture, they are engineered, constructed and tested to make a good first impression while withstanding the rigors of constant use by occupants and visitors.

PERFORMANCE

To resist both lever arm and torsion forces that constantly act on any door, all three entrances feature welded corner construction with Sigma deep penetration and fillet welds plus mechanical fastenings at each corner – a total of 16 welds per door. Each door corner comes with a limited lifetime warranty, good for the life of the door under normal use. It is transferable from building owner to owner and is in addition to the standard two-year warranty covering material and workmanship of each Kawneer door.



1. Thermoplastic elastomer weatherstrip in blade stop of frame jams, header or transom bar.
2. Integral polymeric fin attached to adjustable astragal, creating an air barrier between pairs of doors.
3. Optional surface-applied bottom weatherstrip with flexible blade gasket. Extruded raised lip on threshold to provide continuous contact for bottom weatherstrip.
4. Standard 1/4" beveled glass stops to sheet water and dirt off without leaving residue.
5. Available in all finishes offered by Kawneer.

GENERAL

- Heights vary up to 10'; widths range from approximately 3' to 4'
- Door frame face widths range to a maximum of 4", while depths range to 6"
- Door operation is single- or double-acting with maximum security locks or touch bar panics standard
- Architect's classic 1" round, bent bar push/pull hardware is available in various finishes and sizes
- Infills range from 1/4" to 1"

FOR THE FINISHING TOUCH

Architectural Class I anodized aluminum finishes are available in clear and Permanodic® color choices.

Painted finishes, including fluoropolymer, that meet AAMA 2605 are offered in many standard choices and an unlimited number of specially designed colors.

Solvent-free powder coatings add the "green" element with high performance, durability and scratch resistance that meet the standards of AAMA 2604.

ECONOMY

Kawneer's bulb neoprene weatherstripping forms a positive seal around the door frame and provides a substantial reduction in air infiltration, resulting in improved comfort and economies in heating and cooling costs. The system is wear- and temperature-resistant and replaces conventional weatherproofing. The bottom weatherstrip at the interior contains a flexible blade gasket to meet and contact the threshold, enhancing the air and water infiltration performance characteristics.

190 NARROW STILE ENTRANCE

- Is engineered for moderate traffic in applications such as stores, offices and apartment buildings
- Vertical stile measures 2-1/8", top rail 2-1/4" and bottom rail 3-7/8"
- Results in a slim look that meets virtually all construction requirements

350 MEDIUM STILE ENTRANCE

- Provides extra strength for applications such as schools, institutions and other high-traffic applications
- Vertical stiles and top rails measure 3-1/2"
- Bottom rail measures 6-1/2" for extra durability

500 WIDE STILE ENTRANCE

- Creates a monumental visual statement for applications such as banks, libraries and public buildings
- Vertical stiles and top rail measures 5"; bottom rail measures 6-1/2"
- Results in superior strength for buildings experiencing heavy traffic conditions

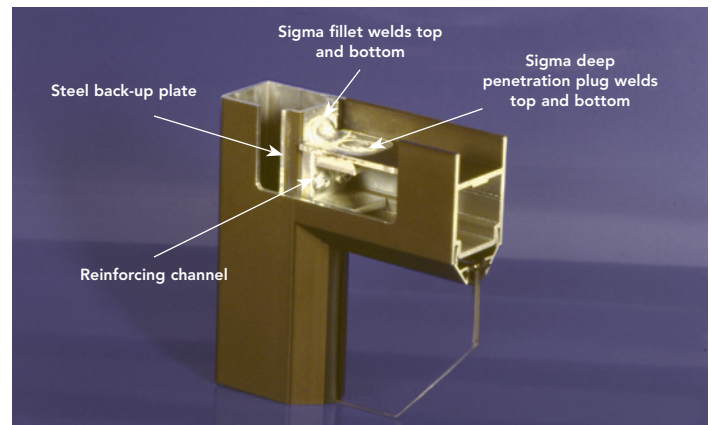

DESIGN AND PERFORMANCE VERSATILITY WITH UNMATCHED FABRICATION FLEXIBILITY

Photography: © Bob Perzel



TRIFAB® VERSAGLAZE® 450, 451 & 451T (THERMAL) FRAMING SYSTEMS & TRIFAB® 451UT (ULTRA THERMAL) FRAMING SYSTEM

Trifab® VersaGlaze® is built on the proven and successful Trifab® platform – with all the versatility its name implies. There are enough framing system choices, fabrication methods, design options and performance levels to please the most discerning building owner, architect and installer. The 4.5" depth Trifab® VersaGlaze® Framing System family is available with non-thermal, thermal and ultra-thermal performance levels. The ultra-thermal Trifab® 451UT Framing System, is designed for the most demanding thermal performance and employs actual Isolock® thermal break.

AESTHETICS

Trifab® VersaGlaze® Framing Systems offer designers a choice of front-, center-, back- or multi-plane glass applications. Structural silicone glazing (SSG) and weatherseal glazing options further expand designers' choice, allowing for a greater range of possibilities for specific project requirements and architectural styles. All systems have a 4-1/2" frame depth; Trifab® VersaGlaze® 450 has 1-3/4" sightlines, while Trifab® VersaGlaze® 451/451T and Trifab® 451UT have 2" sightlines.

With seamless incorporation of Kawneer entrances or windows, including GLASSvent® visually frameless ventilators, Trifab® framing can be used on almost any project. These framing systems can also be packaged with Kawneer curtain walls and overhead glazing, thereby providing a full range of proven, and tested, quality products for the owner, architect and installer from a single-source supplier.

ECONOMY

Trifab® VersaGlaze® 450/451/451T/451UT Framing Systems offer a variety of fabrication choices to suit your project:

- **Screw Spline** – for economical continuous runs utilizing two-piece vertical members that provide the option to pre-assemble units for efficient handling and installation. (available for all Trifab systems)
- **Shear Block** – for punched openings or continuous runs using tubular verticals with shear blocks to connect horizontal members. (available for 450/451/451T systems)
- **Stick** – for fast, easy field fabrication. Continuous sill and head receptors are installed with horizontals connected to tubular verticals with shear blocks. (available for 450/451/451T systems)
- **Pre-glazed** – The combination of screw spline construction with pre-glazing in the shop accelerates installation and reduces field labor time while minimizing disruption to the surrounding area or existing tenants. Making it an exceptional choice for new or retrofit applications, particularly in urban areas or where space is limited. (available for 451/451T/451UT framing)

Photography: © Ben Gancsos



All systems can be flush glazed from either the inside or outside. The weatherseal option provides an alternative to SSG vertical mullions for Trifab® VersaGlaze® 450/451/451T. This ABS/ASA rigid polymer extrusion allows complete inside glazing and creates a flush glass appearance on the building exterior without the added labor of scaffolding or swing stages. Additionally, high-performance flashing options are engineered to eliminate perimeter sill fasteners and associated blind seals.

FOR THE FINISHING TOUCH

Architectural Class I anodized aluminum and painted finishes in fluoropolymer (AAMA 2605) and solvent-free powder coatings (AAMA 2604) offer a variety of color choices.

PERFORMANCE

Kawneer's Isolock® thermal break technology creates a composite section, prevents dry shrinkage and is available on Trifab® VersaGlaze® 451T. For even greater thermal performance, a dual Isolock® thermal break is used on Trifab® 451UT.

U-factor, CRF values and STC ratings for Trifab® framing systems vary depending upon the glass plane application. Project-specific U-factors can be determined for each individual project.

(See the Kawneer Architectural Manual or Kawneer.com for additional information.)

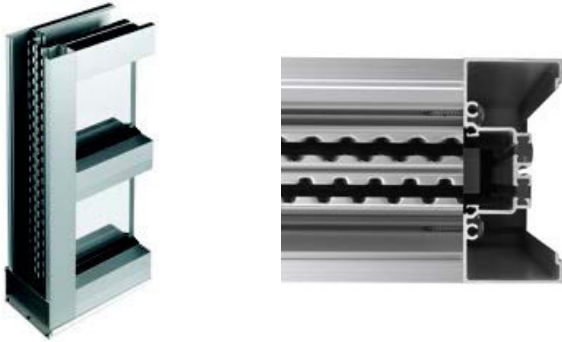

Trifab® 451UT uses a dual Isolock® thermal break (right) and features a new high performance sill design, which incorporates a screw-applied end dam (left), ensuring positive engagement and tight joints between the sill flashing and end dam.

PERFORMANCE TEST STANDARDS

Air Infiltration	ASTM E283
Water	AAMA 501, ASTM E331
Structural	ASTM E330
Thermal	AAMA 1503
Thermal Break	AAMA 505, AAMA TIR-A8
Acoustical	AAMA 1801, ASTM E1425

Thermal simulations showing temperature variations from exterior/cold side to interior/warm side.

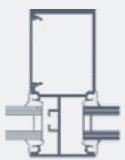
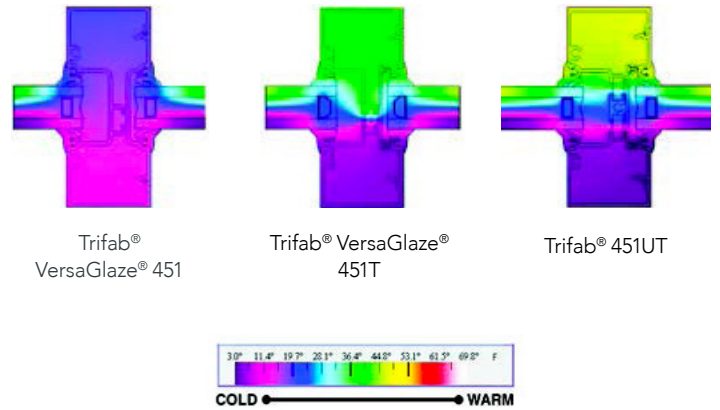

Front

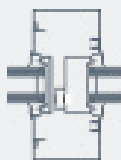

Center

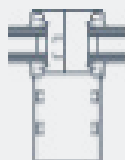

Back

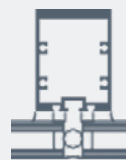

SSG

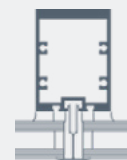

Weatherseal

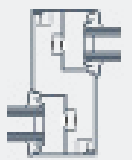

Multi-Plane

Note to Specifiers:

The specifications below are offered as desirable inclusions in glass and glazing specifications (section 08 81 00), but are not intended to be complete. An appropriate and qualified Architect or Engineer must verify suitability of a particular product for use in a particular application as well as review final specifications.

PRODUCTS

Approved Glass Fabricator Oldcastle Glass®

Glass Description FLOAT GLASS

1. USA - Annealed float glass shall comply with ASTM C1036, Type I, Class 1 (clear), Class 2 (tinted), Quality-Q3. Canada - Annealed float glass shall comply with CAN/CGSB-12.3-M, Quality-Glazing.
2. USA- Heat-strengthened float glass shall comply with ASTM C1048, Type I, Class 1 (clear), Class 2 (tinted), Quality Q3, Kind HS. Canada - Heat-strengthened float glass shall comply with CAN/CGSB-12.9-M, Type 2-Heat-Strengthened Glass, Class A-Float Glass.
3. USA - **Tempered** float glass shall comply with ASTM C1048, Type I, Class 1 (clear), Class 2 (tinted), Quality Q3, Kind FT. Canada - Tempered float glass shall comply with CAN/CGSB-12.1-M, Type 2-Tempered Glass, Class B-Float Glass.
4. USA - Laminated glass to comply with ASTM C1172. Canada - Laminated glass to comply with CAN/CGSB-12.1-M, Type 1-Laminated Glass, Class B-Float Glass.
5. Glass shall be annealed, heat-strengthened or tempered as required by codes, or as required to meet thermal stress and wind loads.

Sealed Insulating Glass (IG) Vision Glass (vertical) GENERAL

1. IG units consist of glass lites separated by a dehydrated airspace that is hermetically dual sealed with a primary seal of polyisobutylene (PIB), or thermo plastic spacer (TPS) and a secondary seal of silicone or an organic sealant depending on the application.
2. USA - Insulating glass units are certified through the Insulating Glass Certification Council (IGCC) to ASTM E2190. Canada - Insulating Glass units are certified through the Insulating Glass Manufacturers Alliance (IGMA) to either the IGMAC certification program to CAN/CGSB-12.8, or through the IGMA program to ASTM E2190..

IG VISION UNIT PERFORMANCE CHARACTERISTICS

1. **Exterior Lite** 1/4" Clear
2. **Interior Lite** 1/4" Clear
3. **1/2" Cavity** Air (Standard)
4. **Performance Characteristics**

Winter U-factor/U-Value (Btu/hr-ft ² -F°):	0.47	Visible Light Transmittance:	79%
Summer U-factor/U-Value (Btu/hr-ft ² -F°):	0.50	Visible Light Reflectance (outside):	15%
Solar Heat Gain Coefficient:	0.70	Visible Light Reflectance (inside):	15%
Shading Coefficient:	0.81	Total Solar Transmittance:	61%
Relative Heat Gain (Btu/hr-ft ²):	169	Total Solar Reflectance (outside):	12%
Light to Solar Gain:	1.13	Ultraviolet Transmittance:	50%

Contact Oldcastle Glass® at (866) 653-2278 for samples or additional information concerning performance, strength, deflection, thermal stress or application guidelines. GlasSelect® calculates center of glass performance data using the Lawrence Berkeley National Laboratory (LBNL) Window 5.2 program (version 5.2.17) with Environmental Conditions set at NFRC 100-2001. Gas Library ID#1 (Air) is used for Insulating Glass units with air. Gas Library ID#9 (10% Air/90% Argon) is used for Insulating Glass units with argon. Monolithic glass data is from the following sources: 1. LBNL International Glazing Database (IGDB) version 16.3; 2. Vendor supplied spectral data files. Laminated glass data is from the following sources: 1. LBNL International Glazing Database (IGDB) version 16.3; 2. LBNL Optics 5 (version 5.1 Maintenance Pack 2); 3. Vendor supplied spectral data files; 4. Vendor supplied data.

Insulating Glass

Introduction

Description

Capabilities

Applications

Characteristics

**Additional Important
Information**



Oldcastle Glass®

Where glass becomes architecture™



Jacobson Building at Iowa State University

Ames, Iowa
Architect: Herbert Lewis
Kruse Blunck Architecture

Insulating Glass (IG Units)



Oldcastle Glass®

Where glass becomes architecture™

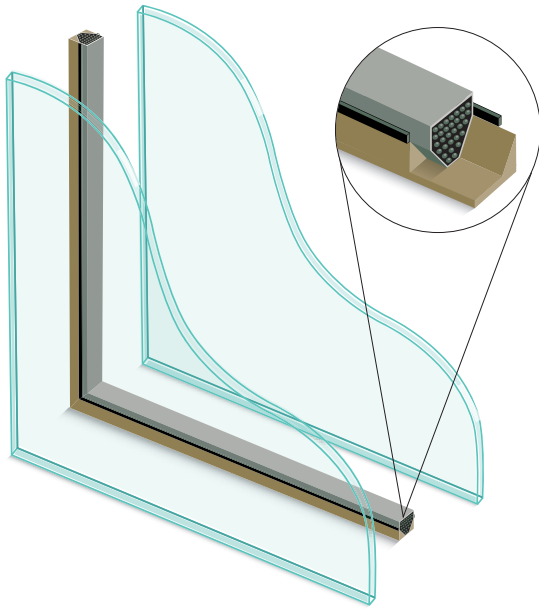

Our IG units are hermetically sealed combinations of two or more lites of glass separated by a dry airspace. IG units improve the thermal performance of windows, thus significantly reducing heating and air-conditioning costs. IG units also reduce interior condensation in cold climates, and increase comfort near windows, thus maximizing the usable interior space.

Insulating Glass Applications

Insulating glass (IG) units are used in a wide range of applications including:

- Commercial/Residential Fixed and Operable windows
- Curtain Walls
- Storefronts
- Sloped/Overhead Glazing
- Nonvision (Spandrel) Locations

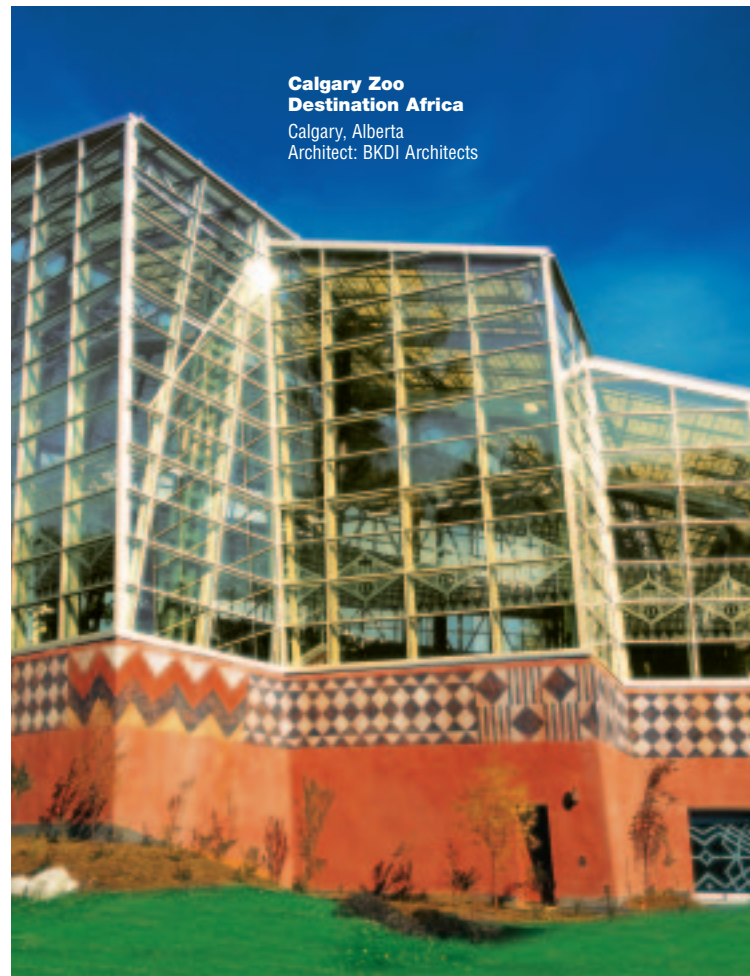

**Calgary Zoo
Destination Africa**
Calgary, Alberta
Architect: BKDI Architects

Insulating Glass

Introduction

Insulating glass use in residential and commercial construction has risen steadily over the years to where the majority of all new and renovation construction today includes IG units. IG units not only save on monthly heating and cooling costs, but they also reduce the initial size and cost of the heating and cooling equipment required on a project.

By combining Low-E coatings, tinted glasses, reflective coatings, silk-screened patterns, laminated glass products and more, a wide variety of insulating glass configurations are available to satisfy a wide range of performance and aesthetic

requirements. IG units can be fabricated to meet state energy codes, sound control requirements, seismic requirements, impact resistance, bullet resistance, and hurricane and blast resistance requirements. IG units can be designed to reduce heat loss and solar heat gain entering the building, with a minimal reduction of visible light transmittance.

IG units will have a warmer room-side glass surface temperature than single glazing, thus reducing condensation and moisture-related problems.

Description

IG units are hermetically sealed combinations of two or more lites of glass separated by a dehydrated airspace. Desiccated spacers are dual sealed with polyisobutylene primary sealant and an organic or silicone secondary sealant, depending on the project specifications and the application. (See the diagrams below.) Argon gas-filled IG units are available to further improve the insulating properties (reduce the U-Value) of a standard air-filled IG unit.

The glass lites of an IG unit can be annealed, heat-strengthened, tempered or laminated, as needed, to meet building code requirements, safety glazing standards and design requirements. The lites of an IG unit can be of equal or unequal thickness.

Insulating Glass Unit

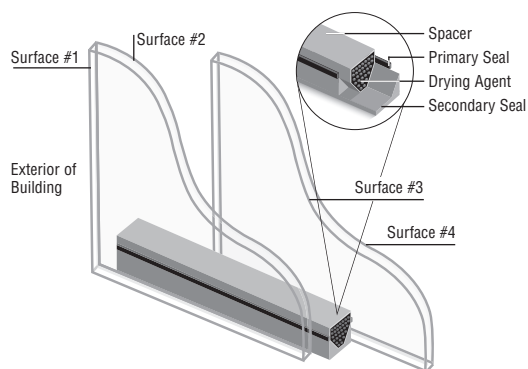

Glass Types Available

Outboard Lite	Inboard Lite
Clear	Clear & Low-E
Tints	Clear & Low-E
Low-E	Clear
Spectrally Selective Tints	Clear & Low-E
Patterned	Clear & Low-E
Reflectives #1 or #2	Clear & Low-E

Others include: Laminated Glass, Spandrel Glass, Wired Glass, Silk-screened Glass and Other Decorative Glass.

(continued on back)

Insulating Glass

Description (continued)

Heat Mirror™ Insulating Glass

Heat Mirror™ insulating glass has a specially coated Low-E film, suspended midway between the lites of glass in the IG unit, to create two dead airspaces, resulting in improved thermal

performance and solar control. In addition, tinted or reflective glasses can be used in the makeup to further enhance aesthetics and solar control.

Heat Mirror™ Offers More Than Twice the Insulation Value of Conventional Glass:

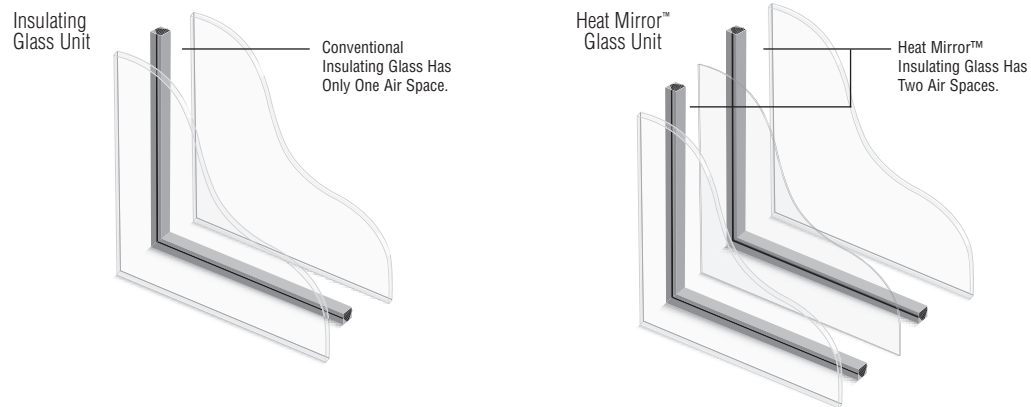

Glass Options

Insulating glass units are fabricated according to project specifications. IG units can be constructed using a large variety of glass products—including clear, low iron, Low-E's, standard or high performance (spectrally selective) tints; and reflective, silk-screened, spandrel, laminated, decorative, and wired glass—to achieve desired aesthetics, meet design criteria and/or to improve solar control and thermal performance.

For a list of available glass products/colors, go to the White Glass Options Tab.

For more information on silk-screened, spandrel and laminated glass products, go to their respective Green Product Information Tabs.

For optical and thermal performance data on IG units, go to the Black Performance Data Tab.

Capabilities

The standard 1" commercial IG unit is made up of two lites of 1/4" glass and a nominal 1/2" airspace. Custom IG unit designs can be fabricated with glass thicknesses ranging from 1/8" to 3/4" and with airspace thicknesses ranging from 3/16" to 7/8".

Maximum sizes for IG units are determined by a number of considerations. Size, thickness, weight, aspect ratio, application and load requirements are the factors utilized to make this determination.

(continued on next page)



Insulating Glass

Capabilities (continued)

Heat Mirror™ Product

Minimum:	5 sq. ft.
Maximum:	71"–One dimension (Film width)
Minimum Size:	12" x 12"
Maximum Size:	71" x 120"
Minimum Unit Thickness:	3/4"

The following Heat Mirror™ films are available with various light transmittance and solar properties: HM TC 88, HM SC 75, HM 77, HM 66, HM 55 and HM 44.

See the Black Product Performance Data Tab for glass performance values with these films and various glass substrates.

Applications

Insulating glass units are used in essentially all exterior building applications, including vertical glazing, sloped glazing, overhead glazing and skylights, in both vision and spandrel (nonvision) areas. Depending on the glass type used, IG units can be designed for light and solar control; sound control; ultraviolet screening (to reduce fading); hurricane, earthquake and blast resistance; security; bullet resistance; and decorative applications.

IG units are also used for interior applications such as sound control and to reduce energy usage for climate-controlled (hot or cold) rooms.

See the White Glass Selector Tab for some typical applications.

Residential Applications

Insulating glass has become the standard for both new and replacement residential windows. Most residential IG units are made with one outboard lite of clear glass and an inboard lite of clear glass, often with a Low-E coating to further reduce heat loss.

When the short-wave infrared (IR) energy of the sun strikes an object in the house, some of the energy is absorbed and reradiated as long-wave IR (heat) energy. The Low-E coating acts to reflect this heat energy back into the residence. In cold climates, the Low-E coating is normally

placed on the #3 surface of the unit. This is done to maximize passive solar heat gain from the sun, while still improving (reducing) the winter nighttime heat loss (winter U-Value). In warm climates, the Low-E coating is positioned on the #2 surface of an IG unit to minimize solar heat gain. The U-Value remains unchanged for the second or third surface application.

Commercial Applications

Most commercial buildings spend the majority of their energy dollars on cooling loads, even in cold climates, due to the internal heat generated by lights, people, copiers, computers and other office equipment. Also, there has been an increase in the number and size of windows to maximize the use of natural daylight to reduce energy usage and lighting costs, as well as the positive effect on employee productivity. Therefore, the major emphasis in commercial buildings is to reduce heat gain (minimize the shading coefficient/the solar heat gain coefficient). Of lesser importance, but still quite significant in cold climates, is the need to minimize nighttime heat loss (winter U-Value).

There are now a large number of high performance/spectrally selective tints, with and without high and low reflective coatings, that do an excellent job of reducing heat gain. And there are a number of Low-E glasses that not only improve (reduce) the winter U-Value, but also reduce heat gain.

Insulating Glass

Characteristics

Certification

Oldcastle Glass® insulating glass units are independently tested and certified according to North American standards for quality and performance. Our IG unit constructions pass the highest level (class CBA) of the ASTM E773/E774 specifications for seal durability. The tests are performed by third-party labs and validated by the Insulating Glass Certification Council (IGCC), which sponsors the certification program and conducts in-plant inspections in the USA. In Canada, insulating glass units are certified through the IGMAC (Insulating Glass Manufacturers Association of Canada), certification program, in accordance with the CGSB 12.8 Standard. Additionally, Canada and the USA are actively promoting member participation in a harmonized insulating glass standard test method that is administered by IGMA (Insulating Glass Manufacturers Alliance) in Canada and through IGCC in the USA. The new standard has been labeled ASTM E2188, E2189 and E2190. Oldcastle Glass® is an active member of IGMA, a unification of the former IG associations of the USA (Sealed Insulating Glass Manufacturers Association) and of Canada (IGMAC). Oldcastle Glass® insulating glass products are listed in the latest version of the *IGCC Certified Products Directory*.

Condensation on Interior Glass Surfaces

Condensation on building interior glass surfaces (the #4 surface of an IG unit) is a common wintertime complaint in much of North America. Condensation not only reduces visibility; it also leads to severe damage of the surrounding construction from this moisture. Condensation occurs on interior glass surfaces when the surface temperatures fall below the dew-point temperature of the room. The relative humidity in a room at which condensation will occur on the glass surface depends on the interior glass

surface temperature, which in turn depends on all the factors affecting heat flow through the glass. These factors include the inside and outside air temperatures and airflows adjacent to the glass surfaces, and the IG unit thermal transmittance (U-Value). Because Low-E glass improves (lowers) the IG unit U-Value, using Low-E glass will increase the unit's interior glass surface temperature. Thus an additional benefit of using Low-E glass is that it permits a higher relative humidity in a room before condensation will occur. This can improve occupant comfort and performance in the winter months.

Vision-Spandrel Color Match

Spandrel glass can be designed to contrast or harmonize with the vision glass. *A wide range of colors and glass products are available to do this, as discussed in the Green Spandrel Tab section of this binder.* The best match for a vision IG unit is a spandrel IG unit using the same exterior glass (normally a tinted or reflective glass) and a spandrel glass as the interior lite, with the coating on the #4 surface on an IG unit.

It should be understood that the degree of color and visual similarity of a building's vision and spandrel glass will vary greatly, depending on the time of day, sky conditions, the vision area lighting and interior shading conditions (drapes, miniblinds, etc.), as well as on the color, reflectance and light transmittance of the glass.

Assuming the vision and spandrel IG units have the same exterior lite, the visual difference between them will be less noticeable under the following conditions:

- the more reflective the exterior lite is
- the lower the light transmittance of the exterior lite is
- the brighter the sky conditions



Insulating Glass

Additional Important Information

Design Criteria

Details on the following important topics can be found in the Black Design Criteria Tab: Glazing Instructions, Thermal Stress, Deflection, Glass Design Loads, Glass Thickness Selection, Spontaneous Breakage of Tempered Glass, Roller Wave Distortion in Heat-treated Glass, Mock-ups and Warranties.

Specifications

A sample Section 08800 Specification for North America can be found in the Black Specifications Tab. Information specific to insulating glass can be found in Part 2 Products, 2.02 Materials.

Contact Us

For any additional information, including details, technical data, specifications, technical assistance and samples, or to speak with an architectural specialist, call 1-866-OLDCASTLE(653-2278).

Visit Us on the Web

Log on to www.oldcastleglass.com for project photos, product colors, general inquiries and project assistance.

To view performance data on a wide range of glass makeups, or to build your own product specification, log on to www.oldcastleglass.com and choose GlasSelect™ 



**THE DOW CHEMICAL COMPANY
SALES SPECIFICATION**

Date Printed: 2025-04-02

Effective Date: 2024-10-23

Supersedes Date: 2018-10-31

Name: DOWSIL™ 795 Silicone Building Sealant Black

Specification Number: 000000839103

Shelf Life

Container Type	Conditions of Handling	Conditions of Storage	Shelf Life	Deterioration Characteristics
All Approved Packaging	Refrigerate > 7 days	Store BELOW 27C/81F	360 Days	

Final Testing Requirements

Test and Test Condition	Limit	Unit	Method	Note
Appearance, uniform viscous paste	Pass		CTM0176	
Tack free time	180 Max	min	CTM0095	
Extrusion rate	75 Min	g/min	CTM0364	
Flow	0.2 Max	inch	CTM0062	
Test Frequency:	audit once per year			
Durometer, 7d/RT	25 Min	ShoreA	CTM0099	
Tensile, 7d/RT	125 Min	psi	CTM0137A	
Elongation, 7d/RT	450 Min	%	CTM0137A	
Tear Die B, 7d/RT	20 Min	lb/in	CTM0159A	

**THE DOW CHEMICAL COMPANY
SALES SPECIFICATION**

Name: DOWSIL™ 795 Silicone Building Sealant Black
Specification Number: 000000839103
Effective Date: 2024-10-23

External Notes

- 1 Dow Chemical warrants that the above designated material conforms to the listed sales specifications even though there may be no value reported.

Test Item	Limits
Flow	< = 0.2 inches
Durometer (7d/RT)	> = 25 Shore A
Tensile (7d/RT)	> = 125 psi
Elongation (7d/RT)	> = 450 %
Tear (7d/RT)	> = 20 lb/inch

READ PRECAUTIONARY INFORMATION AND MATERIAL SAFETY SHEETS. THIS PRODUCT IS SHIPPED IN COMPLIANCE WITH APPLICABLE LAWS AND REGULATIONS REGARDING CLASSIFICATION, PACKAGING, SHIPPING AND LABELING.