



## ADDENDUM

### BESSIE OWENS JR HIGH SCHOOL MODERNIZATION – PHASE III – MODULAR BUILDING ‘L’ & RELATED SITE IMPROVEMENTS

<b>ADDENDUM NO.</b>	Ph3 - Four (4)	<b>DATE:</b>	October 23, 2023
<b>CLIENT / PROJECT:</b>	Bakersfield City School District Bessie Owens Jr. High Modernization – Phase III Modular Building ‘L’ & Related Site Improvements	<b>BID OPENING LOCATION:</b>	Bakersfield City School District 1501 Feliz Drive, Bakersfield, CA 93307
<b>PROJECT NO.</b>	118934 / 19123.03-46	<b>BID DATE:</b>	<b>October 26, 2023</b>
<b>ARCHITECT:</b>	Arcadis - IBI Group 4119 Broad Street Suite 210 San Luis Obispo, CA 93402	<b>BID TIME:</b>	2:00 pm
<b>D.S.A. APPLICATION NO.</b>	03-120102		
<b>D.S.A. FILE NO.</b>	15-6		

NOTICE TO ALL CONTRACTORS SUBMITTING BIDS FOR THIS WORK AND TO ALL PLAN HOLDERS:

You are hereby notified of the following CHANGES, clarifications or modifications to the original Contract Documents, Project Manual, Drawings, Specifications and subsequent Addenda. This Addendum shall supersede the original Contract Documents and previous Addenda wherein it contradicts the same and shall take precedence over anything to the contrary therein. All other conditions remain UNCHANGED.

**I. CHANGES AND/OR CLARIFICATIONS TO PREVIOUS ADDENDUM: N/A**

**II. CHANGES AND/OR CLARIFICATIONS TO THE PROJECT MANUAL AND CONTRACT DOCUMENTS:**

ITEM (01) REFER TO PROJECT MANUAL:

**A. As Point of Clarification:**

All prime contractors performing site work:  
 Sheet C1.4 identifies the limits of Building L and Related Site Improvements scope of work. The site improvements outside of the highlighted area have been included in previous construction phases. BP-01 Site demolition will include all asphalt, concrete, fencing and all miscellaneous site items to be removed for site improvements located in the area limits highlighted on Sheet C1.4.

BP-01 Site demolition contractor shall remove the drain box and drywell on the north end of Building L shown on sheet C1.4.



## ADDENDUM

### B. Bid Package 01 – Site Demolition, Grading & Concrete

1. **Refer** to BP 01, Item 41: Concrete pad for drinking fountain shall be 4'-0" x 6'-0" x 4" thick. Provide steel pipe barrier rails at drinking fountain. Refer to Addendum 3, Sketch PH3 ADD03 A1 for barrier rail detail. Barrier rail at drinking fountain shall be 2'-0" wide.

### III. CHANGES AND/OR CLARIFICATIONS TO THE DRAWINGS: N/A

### IV. PRE-BID RFI'S

#### **BP-03**

**Q:** The Bid Package 3 work scope summary, Items 30 states, "Relocate exterior drinking fountain to the south side of Building L". I cannot find an existing exterior fountain on the plans. Nor can I find a make and model for the existing fountain. Please clarify.

**R:** The existing exterior drinking fountain is located between Buildings R6 and R7 on the west end of the buildings, see site demolition plan A1000 for location reference. The existing drinking fountain is a Haws model 3300. **Drinking fountain specifications**, attached.

### CONFORMANCE WITH CONTRACT DOCUMENTS, PROJECT MANUAL, DRAWINGS AND SPECIFICATIONS

All addenda work shall be in strict conformance with the Contract Documents, Project Manual, Drawings and Specifications as they pertain to work of a similar nature.

IBI GROUP, a CALIFORNIA PARTNERSHIP

BY:

  
RICHARD MELLO, AIA #C-18079

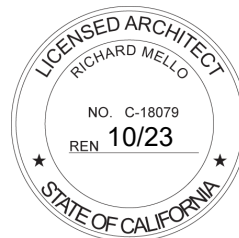

REQUEST FOR INFORMATION

PROJECT: Bessie Owens MS. Phase 3 JOB # \_\_\_\_\_

OWNER: BCSD

ARCHITECT: IBI

INFORMATION REQUESTED FROM:

Taft Plumbing Co. Inc.  
(PRIME CONTRACTOR)

BID PACKAGE #: 3

PHONE: 661-765-2454

FAX: 661-763-1367

To: BCSD  
ATTN: Jason Sitton

SUBJECT: Drinking fountain

CONTRACTOR'S RFI # \_\_\_\_\_

DATE OF REQUEST: 10-20-23

RFI # \_\_\_\_\_

DATE INFORMATION REQUIRED: Pre Bid

REQUEST: The bid package 3 work scope summary, item 3D states "relocate existing exterior drinking fountain to the south side of Building L" I cannot find an existing exterior fountain on the plans. Nor can I find a make and model for the existing fountain. Please clarify

CC: \_\_\_\_\_ BY: \_\_\_\_\_

REPLY: \_\_\_\_\_

The existing exterior drinking fountain is located between Buildings R6 and R7 on the west end of the buildings, see site demolition plan A1000 for location reference. The existing drinking fountain is a Haws model 3300. Drinking fountain specifications attached.

BY: \_\_\_\_\_ DATE: \_\_\_\_\_

ARCHITECT OR  CONSTRUCTION MANAGER



# model 3300

ADA Outdoor Vandal-Resistant Steel Pedestal Fountain

## FEATURES & BENEFITS

### CONSTRUCTION

Barrier-free design made of heavy-duty 11 gauge galvanized steel with green powder-coat finish. Unit has a high-polished stainless steel basin that resists stains and corrosion, recessed push-button, welded bubbler guard, and vandal-resistant bottom plate.

### DRAIN CLEAN-OUT

Top-down access to the drain allows the fountain portion to be cleaned without taking the unit apart, good for outdoor settings with drain-clogging sediment such as leaves, garbage, and other debris.

### BARRIER-FREE

Barrier-free capabilities combined with its ease of use allows for a number of installation location possibilities.

### DRINKING FOUNTAIN VALVE

The push-button activated valve offers the only all stainless steel valve body that is machined out of solid bar stock, is fully serviceable through the front of the push button assembly offering access to the water control cartridge and integral water supply strainer, and with front access to the water stream height adjustment for easy maintenance without having to remove the valve. Operating pressure range of 30 to 90 psi (2.1 to 6.2 bar).

### VANDAL-RESISTANT

The bubbler heads, push buttons, drain strainers and access plates are locked in place, discouraging unwanted vandal tampering.



## SPECIFICATIONS

Model 3300 ADA vandal-resistant pedestal drinking fountain shall include an 11 gauge galvanized substrate steel pedestal with green powder-coating, polished stainless steel basins, vandal-resistant push-button operated stainless steel valves with front-accessible cartridge and flow adjustment, polished chrome-plated brass vandal-resistant shielded bubbler head, 100% lead-free waterways, polished chrome-plated vandal-resistant waste strainers with top-down clean-out access, vandal-resistant access plates, integral mounting feet, and 1-1/2" slip waste.

## APPLICATIONS

The 3300 offers a solution for outdoor wheelchair access as well as vandal-resistance, appealing to all users through accessibility and safety. This series may also be a nice addition to areas such as parks, schools, and other areas where drinking facilities are needed. Model meets all current Federal Regulations for the disabled including those in the Americans with Disabilities Act. Haws manufactures drinking fountains, faucets and electric water coolers to be lead-free by all known definitions including NSF/ANSI/CAN 61-Section 9, NSF/ANSI/CAN 372, California Proposition 65, and the Federal Safe Drinking Water Act. Product is compliant to California Health and Safety Code 116875 (AB 1953-2006), and NSF/ANSI/CAN 61: Q ≤ 1.

## OPTIONS

Sand Trap: Model 6611, sand trap for installing adjacent to pedestal drinking fountains to help prevent debris and contaminants from clogging waste line.

Faucet Valve: Model 6250LF, self-closing, plain end, lead-free, brass bib faucet with polished chrome-plated finish. (When used with Haws concrete products, also order part 0004499489; for 3511, use 0004521763)

Valve Repair Kit: Model VRK5874, valve repair kit for Model 5874.

For more information, visit [www.hawsc.com](http://www.hawsc.com) or call (888) 640-4297.



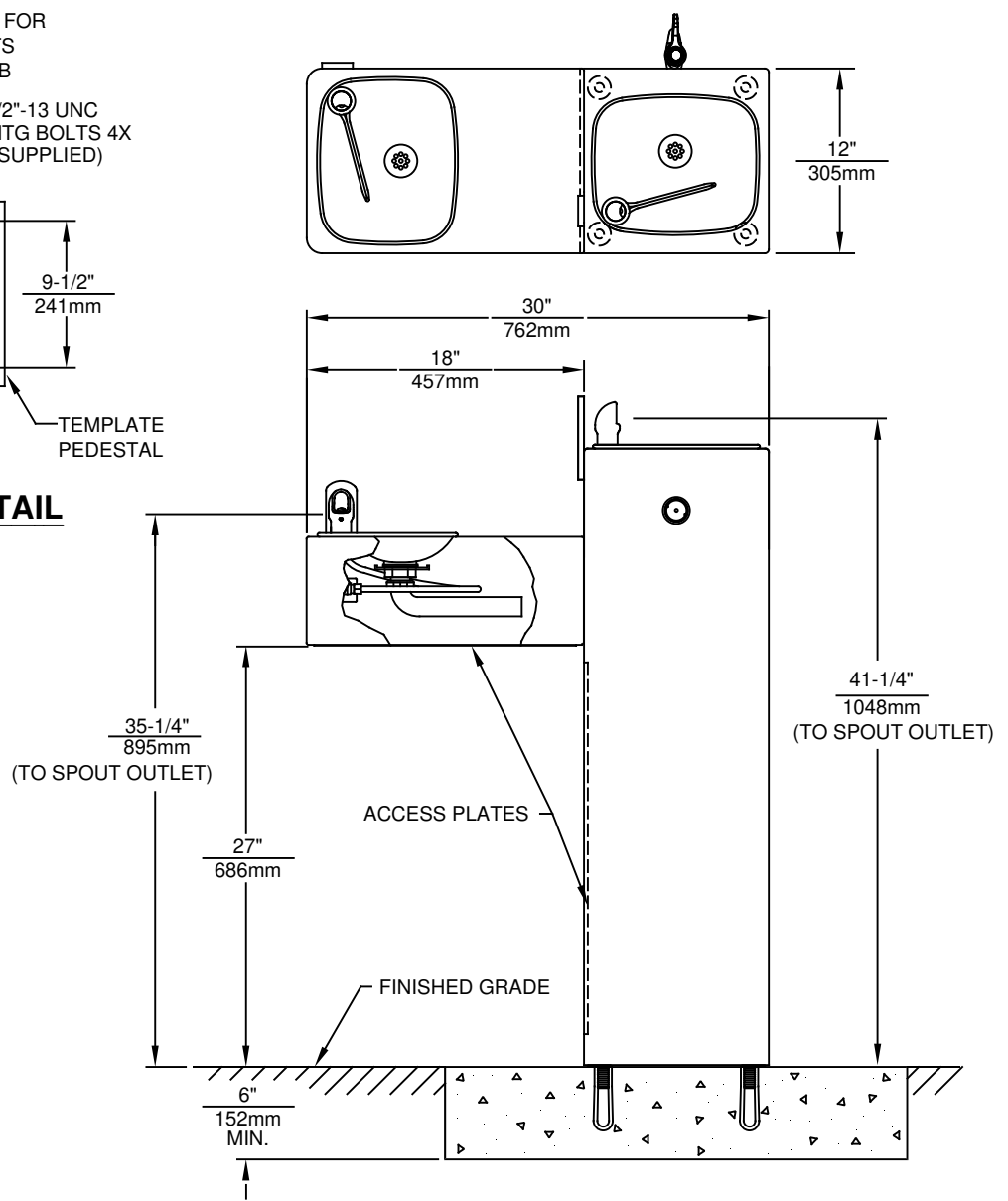
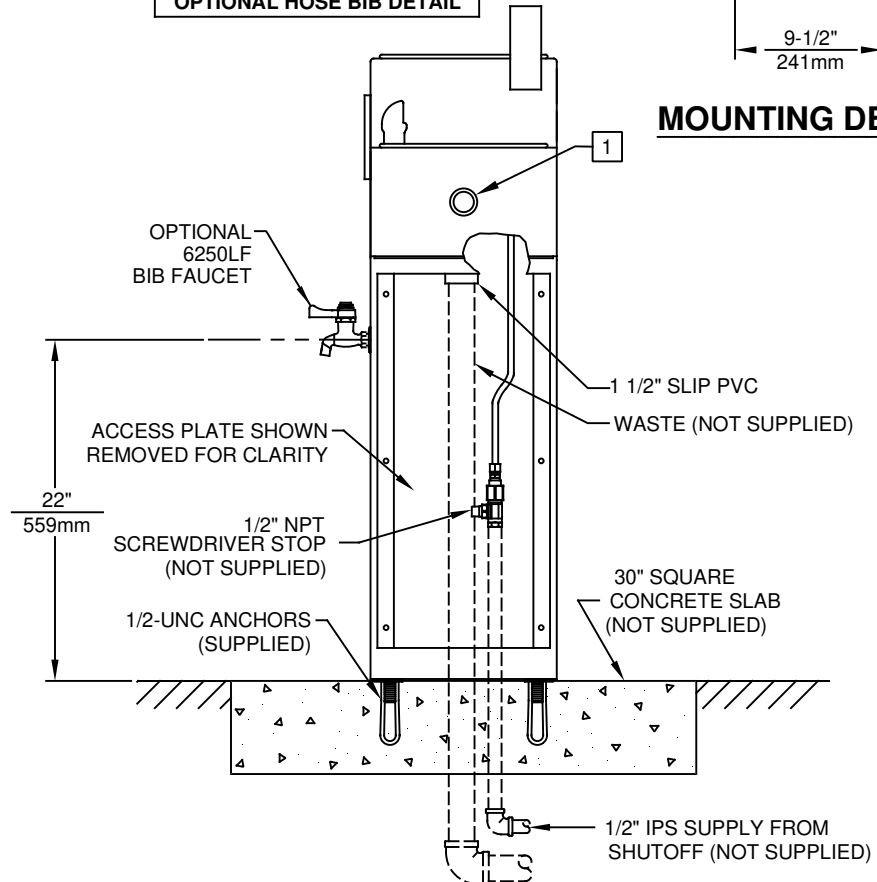
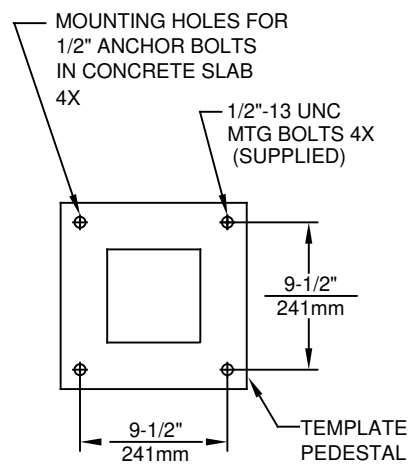
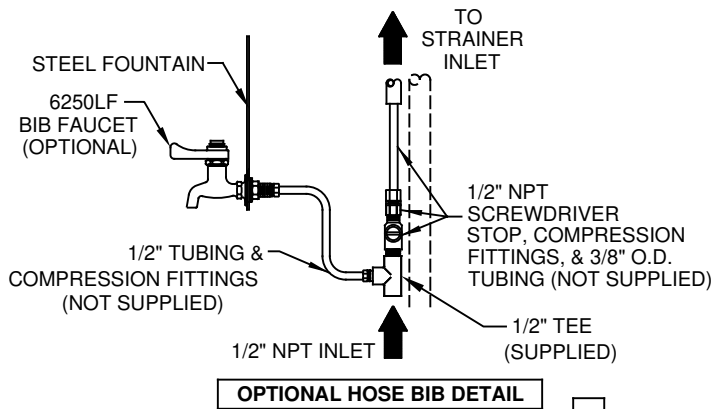

**NOTES:**

- 1 REFER TO 5874 SERIES OPERATION AND MAINTENANCE MANUAL FOR PUSH BUTTON AND VALVE INSTALLATION/MAINTENANCE INSTRUCTIONS. (NOTE: THIS FOUNTAIN UTILIZES A HIGH FLOW CARTRIDGE TO ENSURE PROPER WATER FLOW).



1455 KLEPPE LANE  
SPARKS, NEVADA 89431  
(775) 359-4712 FAX (775) 359-7424  
E-MAIL: HAWS@HAWSCO.COM  
WEBSITE: WWW.HAWSCO.COM

ECN NO.	REVISED PER	BY:	MODEL(S)	PART NUMBER
	ECN: 5189	JP		0002077341.D
DRAWN:	DATE:	CHK'D:	3300/3300G	REVISION
CJL	09/92	VWG		21
APPROVED:	DATE:	SCALE:	DRAWING TYPE:	INSTALLATION
FV	07/07/17	N/A		SIZE: A SHEET 1 OF 1

