



01-1483

Date: June 1, 2026

Submittal No: 0010

Project: Franklin ES Mod. BP 02 General
2400 Truxtun Ave.
Bakersfield, CA 93301

Owner: Bakersfield City School District
1300 Baker St.
Bakersfield, CA 93305

Architect: SCArchitect, Inc.
1601 New Stine Rd. Ste. 280
Bakersfield, CA 93309

Contractor: JTS Construction
P.O. Box 41765
Bakersfield, CA 93384-1765

Subcontractor: Champion

Submittal: 081100 – Doors & Hardware

Contractor's Stamp

JTS CONSTRUCTION
BY: Diego Ross
DATE: June 1, 2026

| |
|----------|
| REVIEWED |
|----------|

/RESUBMIT

Architect's Stamp

HM FRAMES, WOOD DOORS, FINISH HARDWARE SCHEDULE

Presented by :
CHAMPION HARDWARE, INC.
3203 PEGASUS DRIVE
BAKERSFIELD, CA 93308
(661) 399-7441 fax(661) 399-7798

PROJECT

| | |
|-----------------|--|
| Name : | FRANKLIN ELEMENTARY SCHOOL MODERNIZATION |
| Street : | 2400 TRUXTUN AVE |
| City : | BAKERSFIELD |
| State/Zip : | CA 93301 |
| Phone/Fax : | () fax() |
| Proj. Manager : | RUSSELL COKER |

CONTRACTOR

ARCHITECT

| | | | | | | | | | | | | | | | | | | | | | |
|--|----------------------------------|--------------------------|-----------|----------------|--------|-------------|-------------|----------|-------------|----------------------------------|---|--------|--------------------|-----------|-------------------------|--------|-------------|-------------|----------|-------------|----------------------------------|
| <table style="width: 100%;"> <tr> <td style="width: 25%;">Name :</td> <td>J T S CONSTRUCTION, INC.</td> </tr> <tr> <td>Address :</td> <td>P.O. BOX 41765</td> </tr> <tr> <td>City :</td> <td>BAKERSFIELD</td> </tr> <tr> <td>State/Zip :</td> <td>CA 93384</td> </tr> <tr> <td>Phone/Fax :</td> <td>(661) 835-9270 fax(661) 835-8424</td> </tr> </table> | Name : | J T S CONSTRUCTION, INC. | Address : | P.O. BOX 41765 | City : | BAKERSFIELD | State/Zip : | CA 93384 | Phone/Fax : | (661) 835-9270 fax(661) 835-8424 | <table style="width: 100%;"> <tr> <td style="width: 25%;">Name :</td> <td>S C ARCHITECT INC.</td> </tr> <tr> <td>Address :</td> <td>1601 NEW STINE RD # 280</td> </tr> <tr> <td>City :</td> <td>BAKERSFIELD</td> </tr> <tr> <td>State/Zip :</td> <td>CA 93309</td> </tr> <tr> <td>Phone/Fax :</td> <td>(661) 397-4377 fax(661) 397-4378</td> </tr> </table> | Name : | S C ARCHITECT INC. | Address : | 1601 NEW STINE RD # 280 | City : | BAKERSFIELD | State/Zip : | CA 93309 | Phone/Fax : | (661) 397-4377 fax(661) 397-4378 |
| Name : | J T S CONSTRUCTION, INC. | | | | | | | | | | | | | | | | | | | | |
| Address : | P.O. BOX 41765 | | | | | | | | | | | | | | | | | | | | |
| City : | BAKERSFIELD | | | | | | | | | | | | | | | | | | | | |
| State/Zip : | CA 93384 | | | | | | | | | | | | | | | | | | | | |
| Phone/Fax : | (661) 835-9270 fax(661) 835-8424 | | | | | | | | | | | | | | | | | | | | |
| Name : | S C ARCHITECT INC. | | | | | | | | | | | | | | | | | | | | |
| Address : | 1601 NEW STINE RD # 280 | | | | | | | | | | | | | | | | | | | | |
| City : | BAKERSFIELD | | | | | | | | | | | | | | | | | | | | |
| State/Zip : | CA 93309 | | | | | | | | | | | | | | | | | | | | |
| Phone/Fax : | (661) 397-4377 fax(661) 397-4378 | | | | | | | | | | | | | | | | | | | | |

Contractor's Project # :

Salesman :

PreparedBy:

JOHN FRAYRE

JOHN FRAYRE

Status: COMPLETE

Date Keying Submitted :

Date Keying Approved :

This Schedule is based on Plans dated :

Date Schedule Submitted :

Date Schedule Approved :

| | | | |
|--|------------------|-------------------------|----------------|
| Project : FRANKLIN ELEMENTARY SCHOOL MODERNIZATION | Control # : 2252 | Print Date : 06/01/2026 | Project # : |
| Supplier : CHAMPION HARDWARE, INC. | Revision # : | Rev Date : | Cover Page : 1 |

Policy Notes

- 01 Only schedules that are stamped "**Final Approved**" are authorized for use by other trades and for installation.
- 02 No material will be ordered until material schedule and keying have been approved by the proper authority.
- 03 Approval of this schedule constitutes an agreement between the contractor and/or architect that all items listed are correct.
- 04 Orders placed with our suppliers cannot be canceled, changed or held up, except with our consent and upon terms that will indemnify us against loss.
- 05 Because the **material for this job** is special in nature and in most cases is ordered specifically for this job, it **cannot be returned for credit.**
- 06 Once an acceptable delivery date is agreed upon, the date cannot be changed unless satisfactory to all parties concerned.
- 07 We cannot be responsible for delays caused by strikes or acts of God or other actions beyond our control.
- 08 Claims for shipment shortages must be made within five (5) days after delivery is signed for, unless prior arrangement has been made for our personnel to check the material in at the jobsite.
- 09 We will replace defective material upon notice. However, we will not be liable for damages, defects or any claim for expense involved by any other trade or user of our products.
- 10 Back charge claims for late delivery, re-work, adjustments or alteration of material will not be considered unless presented in writing and approved by corporate officers in advance.
- 11 Approved change orders for additions or deletions will be incorporated into this schedule by the Contractor.

| | | | |
|--|------------------|-------------------------|-----------------|
| Project : FRANKLIN ELEMENTARY SCHOOL MODERNIZATION | Control # : 2252 | Print Date : 06/01/2026 | Project # : |
| Supplier : CHAMPION HARDWARE, INC. | Revision # : | Rev Date : | Policy Page : 1 |

Abbreviations

| | |
|------------------|---|
| 16CRS | CECO FRAME MATERIAL: |
| 626 | HARDWARE FINISH: SATIN CHROMIUM PLATED OVER NICKEL |
| 630 | HARDWARE FINISH: SATIN STAINLESS STEEL |
| A | DOOR ID: ACTIVE OF A SINGLE DOOR |
| AL | HARDWARE FINISH: ALUMINUM MILL FINISH |
| BLK | HARDWARE FINISH: BLACK |
| CYL | CYLINDER |
| F/S | DOOR FINISH: FACTORY STAINED AND POLYBAGGED |
| FPC | CECO FRAME FINISH: PRIME COATED AT THE FACTORY |
| GRY | HARDWARE FINISH: GREY |
| HMF | FRAME TYPE: HOLLOW METAL FRAME |
| LHR | HAND: Left Hand Reverse |
| NRP | NON-REMOVEABLE PIN (IN HINGE) |
| PC | DOOR CORE: PARTICLEBOARD CORE |
| PSWBIRCH | DOOR FACE: PLAIN SLICED WHITE BIRCH |
| RHR | HAND: Right Hand Reverse |
| SGL | MODE OF OPERATION: SINGLE DOOR |
| WD | DOOR TYPE: WOOD DOOR |
| WELDCORNE | CECO FRAME CONSTRUCTION: WELDED CORNERS ONLY |

| | | | |
|--|------------------|-------------------------|------------------------|
| Project : FRANKLIN ELEMENTARY SCHOOL MODERNIZATION | Control # : 2252 | Print Date : 06/01/2026 | Project # : |
| Supplier : CHAMPION HARDWARE, INC. | Revision # : | Rev Date : | Abbreviations Page : 1 |

Manufacturers

| Abbrev | Name |
|--------|------------------------------------|
| CEC | CECO DOOR |
| IVE | H.B. IVES |
| MCK | MCKINNEY PRODUCTS CO |
| NOR | NORTON DOOR CONTROLS |
| ORE | OREGON DOOR |
| PEM | PEMKO MANUFACTURING |
| TRI | TRIMCO |
| YAL | YALE COMMERCIAL LOCKS AND HARDWARE |

| | | | |
|--|------------------|-------------------------|------------------------|
| Project : FRANKLIN ELEMENTARY SCHOOL MODERNIZATION | Control # : 2252 | Print Date : 06/01/2026 | Project # : |
| Supplier : CHAMPION HARDWARE, INC. | Revision # : | Rev Date : | Manufacturers Page : 1 |

Finishes

| Finish Code | Description |
|-------------|-----------------------------------|
| 626 | SATIN CHROMIUM PLATED OVER NICKEL |
| 630 | SATIN STAINLESS STEEL |
| AL | ALUMINUM MILL FINISH |
| F/S | FACTORY STAINED AND POLYBAGGED |
| FPC | PRIME COATED AT THE FACTORY |
| GRY | GREY |

| | | | |
|--|------------------|-------------------------|-------------------|
| Project : FRANKLIN ELEMENTARY SCHOOL MODERNIZATION | Control # : 2252 | Print Date : 06/01/2026 | Project No: |
| Supplier : CHAMPION HARDWARE, INC. | Revision #: | Rev Date : | Finishes Page : 1 |

Clarifications

CLARIFY JAMB SIZES ON FIELD
CLARIFY JAMB ANCHORS

| | | | |
|--|------------------|-------------------------|--------------|
| Project : FRANKLIN ELEMENTARY SCHOOL MODERNIZATION | Control # : 2252 | Print Date : 06/01/2026 | Project No: |
| Supplier : CHAMPION HARDWARE, INC. | Revision # : | Rev Date : | Page: 1 of 1 |

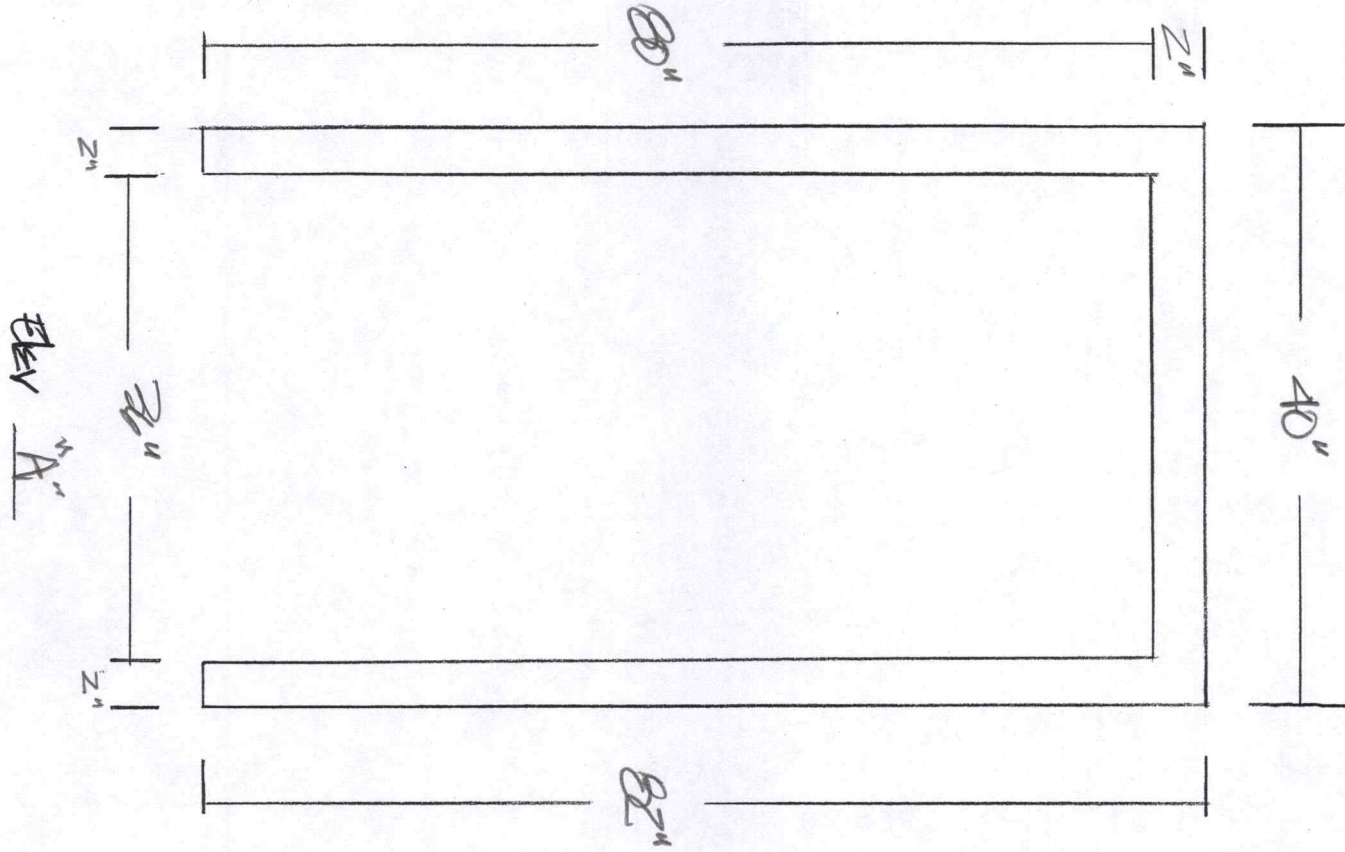

Elev. AA

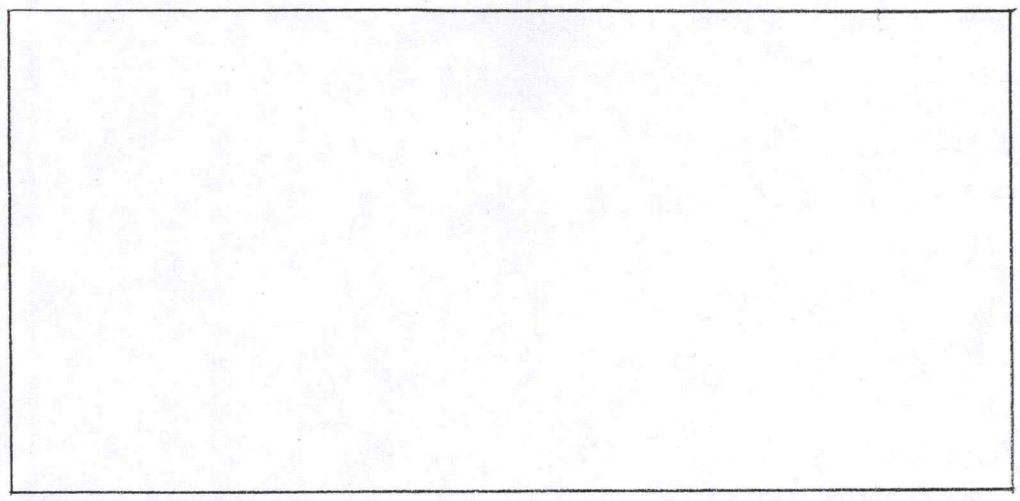

SERIES SU STEEL FRAMES (UNEQUAL RABBET)

STANDARD SIZES NOMINAL DOOR OPENING

| WIDTH | | HEIGHT |
|--------|--------|--------|
| SINGLE | DOUBLE | |
| 2'-0" | 4'-0" | 6'-8" |
| 2'-4" | 4'-8" | |
| 2'-6" | 5'-0" | |
| 2'-8" | 5'-4" | |
| 2'-10" | 5'-8" | |
| 3'-0" | 6'-0" | |
| 3'-4" | 6'-8" | |
| 3'-6" | 7'-0" | |
| 3'-8" | 7'-4" | |
| 3'-10" | 7'-8" | |
| 4'-0" | 8'-0" | |
| 5'-0" | 10'-0" | |

FIRE DOOR FRAMES

LABELING AGENCIES :
UL SOLUTIONS
WARNOCK HERSEY
FACTORY MUTUAL

TEST: UL10B, UL10C, UL1784 & NFPA 252

RATING: 20 MIN, 3/4 HR, 1 HR, 1-1/2 HR, OR 3 HR

MAX. SIZE: 4'0" X 10'0" SINGLE
8'0" X 10'0" PAIR

NOT ALL RATINGS ARE AVAILABLE IN ALL SIZES, DESIGNS AND MATERIALS. HOURLY CLASSIFICATIONS ARE NOT SHOWN ON LABEL UNLESS CLASS IS LESS THAN 3 HOURS.

PRODUCT SPECIFICATIONS:

Steel door frames shall be as manufactured by Ceco Door Products, Milan, TN or Mason City, IA USA. They shall conform to the Steel Door Institute guide specification, ANSI A250.8. See chart below for performance classifications.

Series SU frames for 1-3/4" doors are formed from commercial quality cold rolled steel conforming to ASTM A1008 ...or (optional) hot-dipped galvanized or galvanized steel conforming to ASTM A924 and A653 - see chart below.

Frames are knocked down (K.D.) field assembled type or welded unit type. Head and jamb members of K.D. frames have diecut mitered corners that interlock rigidly when field assembled. Integral door stops are 5/8" high. Jambs are sized to suit wall applications. Twist-in anchors are available for new masonry, wood stud, metal stud, or existing opening wall conditions (indicate which). Floor anchors or extra jamb anchors are provided to anchor sill. Welded-in jamb anchors are also available.

Hardware Provisions: Frames are handed. Hinge jambs are mortised for 4-1/2" or 5" high, standard and heavy weight hinges (specify which). 7 gauge steel reinforcements are welded in place and are drilled and tapped for fasteners in accordance with ANSI A156.7. The strike jamb is prepared for 4-7/8" universal or 2-3/4" cylindrical strike in accordance with ANSI A115.1 & 2 (specify which). Plaster guards are provided. Optional closer reinforcement is a 14 gauge steel formed steel sleeve (12 gauge upon request). 3 mute holes are provided per strike jamb and 2 for double swing heads.

Paint: Steel door frames are provided with one coat of oven-cured neutral color primer paint. Primer coat shall conform with ANSI A250.10. The primer coat is a preparatory base for necessary finish painting. "Colorstyle" finish coat is also available on K.D. frames from a selection of standard colors (optional). Colorstyle finish is electrostatically applied, oven-cured urethane enamel, and shall conform to ANSI A250.3. For accurate color selectors ask for a Ceco Colorstyle chart.

MATERIAL

| DOOR FRAME MATERIAL | LEVEL | C.R. | GALV | |
|---------------------|---------------------------|------|------|-----|
| | | | A60 | G90 |
| 16 GAUGE STEEL | HEAVY OR EXTRA HEAVY DUTY | STD | OPT | OPT |
| 14 GAUGE STEEL | MAXIMUM DUTY | STD | OPT | OPT |

PERFORMANCE

PHYSICAL ENDURANCE LEVEL: MEETS ANSI A250.4 PERFORMANCE TEST -- 16 & 14 GAUGE STEEL: LEVEL A (1,000,000 CYCLES)

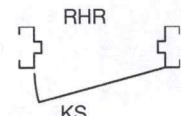
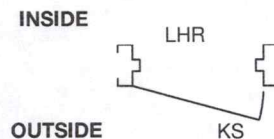
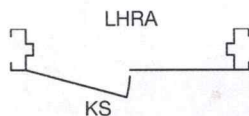
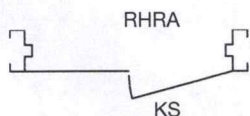

"KS" = KEY SIDE "SUFFIX" A" = ACTIVE LEAF OF PAIRS

(CONVERSION: 1" = 25.4 MM, E.G., 1-3/4" = 44.45 MM)

SERIES SU STEEL FRAMES (UNEQUAL RABBET)

1 KNOCKED DOWN (KD) CORNER CONSTRUCTION

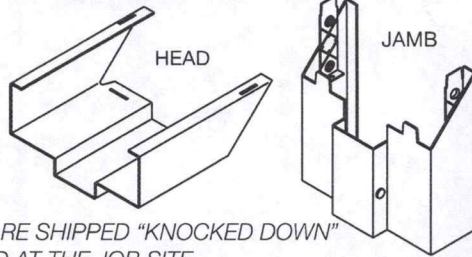

COMPONENTS ARE SHIPPED "KNOCKED DOWN" AND ASSEMBLED AT THE JOB SITE

1 WELDED CORNERS

DIE-CUT CORNER WITH CORNER TAB AND FACE WELD SHOWN.

ALSO AVAILABLE WITHOUT TAB AND WELDED OR MITRE SAWED AND WELDED.

ALTERNATIVE WELD OPTIONS ARE ALSO AVAILABLE.

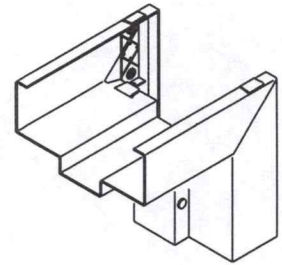

2 HINGE PREPARATION

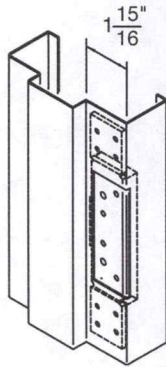

4-1/2" X .134" OR
4-1/2" X .180"
ANSI A156.7 TEMPLATE
7 GAUGE STEEL REINFORCING

2 HINGE PREPARATION

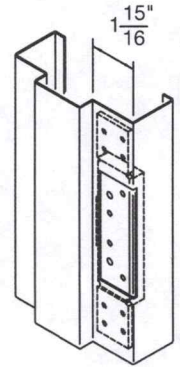

5" X .146" OR
5" X .190"
ANSI A156.7 TEMPLATE
7 GAUGE STEEL REINFORCING

3 LOCK STRIKE PREPARATION

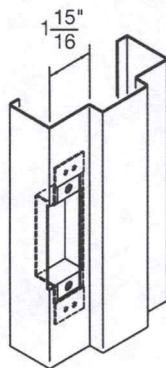

S
UNIVERSAL (4-7/8")
ANSI A115.1 & 2 TEMPLATE
16 GAUGE STEEL REINFORCING
WITH EXTRUDED SCREW HOLES
PROVIDES EQUIVALENT THREAD
ENGAGEMENT EQUAL TO 14 GAUGE.
STANDARD FOR 1-3/4" DOORS

3 LOCK STRIKE PREPARATION

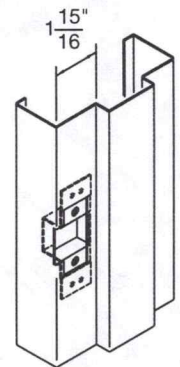

C
CYLINDRICAL (2-3/4")
ANSI A115.3 TEMPLATE
16 GAUGE STEEL REINFORCING
WITH EXTRUDED SCREW HOLES
PROVIDES EQUIVALENT THREAD
ENGAGEMENT EQUAL TO 14 GAUGE.
OPTIONAL FOR 1-3/4" DOORS
ALSO AVAILABLE WITHOUT LIP NOTCH FOR DEADBOLTS.

4 WOOD STUD ANCHOR WS

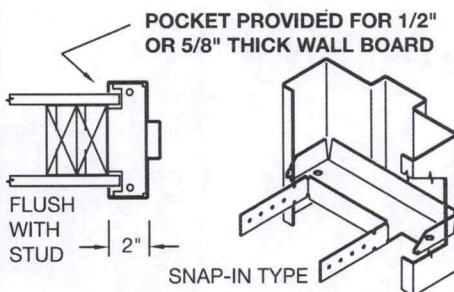

(USED ALSO FOR METAL STUD WALLS)

4 METAL STUD ANCHOR MS

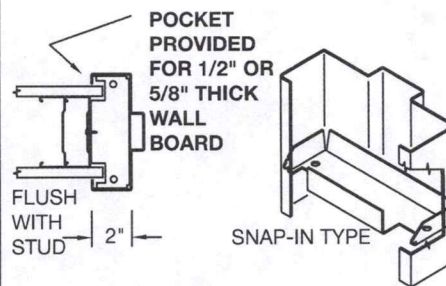

4-3/4" AND 5-3/4" DEPTH ONLY
FOR OTHER DEPTHS USE WS TYPE.

4 FIXED FLOOR ANCHOR SA

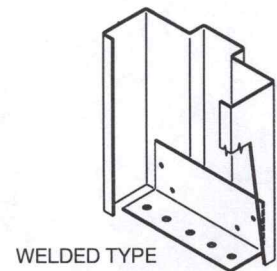

ONE PIECE

F1-1

SERIES SU STEEL FRAMES (UNEQUAL RABBET)

FOR 1-3/4" THICK DOORS - STANDARD WALL APPLICATION, HANDED

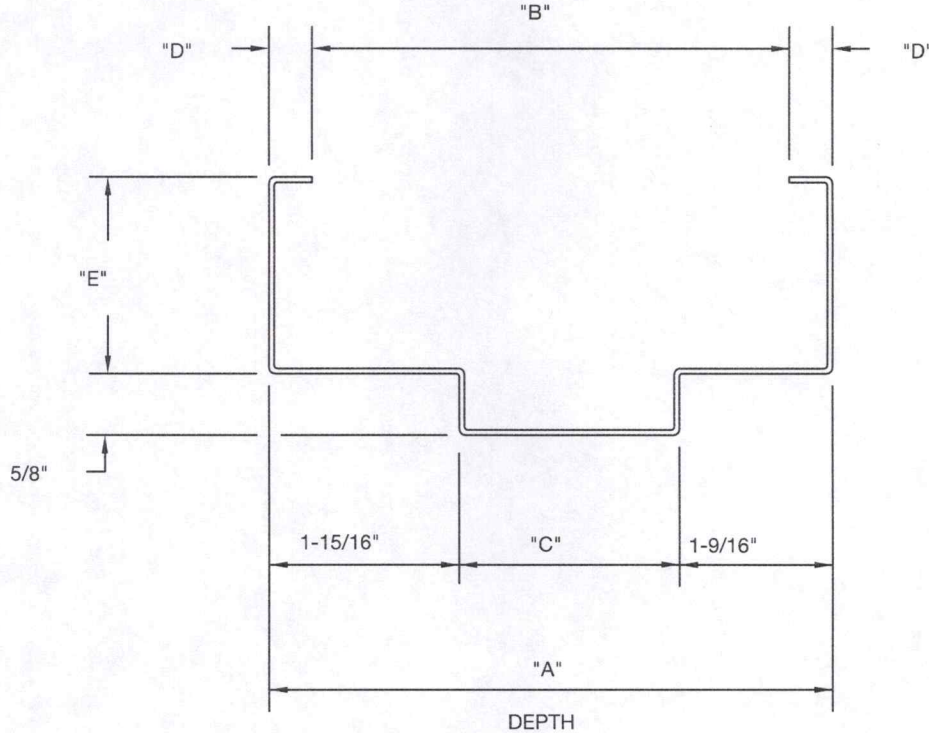

| DEPTH | A | B | C | D | E | |
|-------|--------|--------|--------|-------|--------------|--------------|
| | | | | | HEAD & JAMBS | HEAD & JAMBS |
| 434 | 4-3/4" | 3-3/4" | 1-1/4" | 1/2" | 2" | 1" |
| 534 | 5-3/4" | 4-7/8" | 2-1/4" | 7/16" | 2" | 1" |
| 634 | 6-3/4" | 5-3/4" | 3-1/4" | 1/2" | 2" | 1" |
| 734 | 7-3/4" | 6-3/4" | 4-1/4" | 1/2" | 2" | 1" |
| 834 | 8-3/4" | 7-3/4" | 5-1/4" | 1/2" | 2" | 1" |

SERIES SU, DOUBLE RABBET FRAMES (WITH UNEQUAL RABBETS) ARE ALSO AVAILABLE IN A RANGE OF DEPTHS FROM: 4-5/8" THRU 14" IN 1/8" INCREMENTS. 4" FACE HEADS WITH 2" FACE JAMBS ARE ALSO AVAILABLE IN SELECTED SIZES.

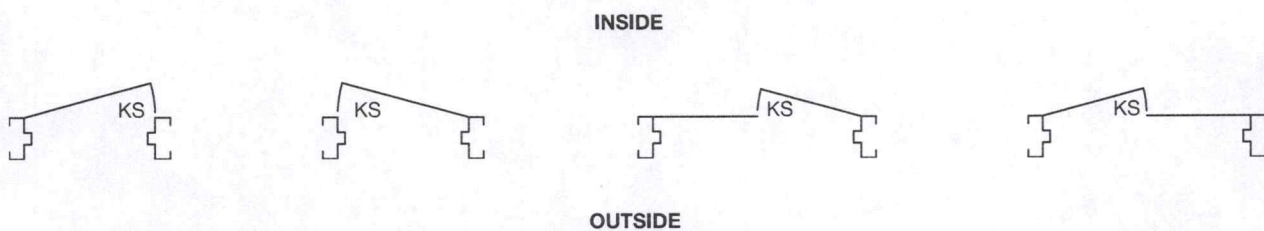

"KS" = KEY SIDE

(CONVERSION: 1" = 25.4 MM, E.G., 1-3/4" = 44.45 MM)

10/18/19

← BACK

CONTENTS

FRAMES

DOORS

WINDSTORM

SPECIALTY

F1-2

SERIES SU STEEL FRAMES (UNEQUAL RABBET)

HARDWARE LOCATIONS SHOWN MATCH CECO STANDARD DOORS.

VERTICAL SECTION

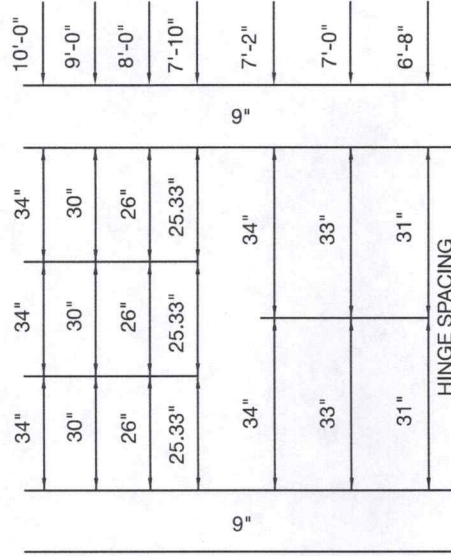
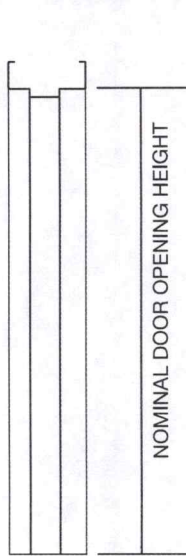

ELEVATION

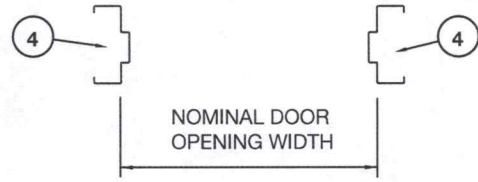
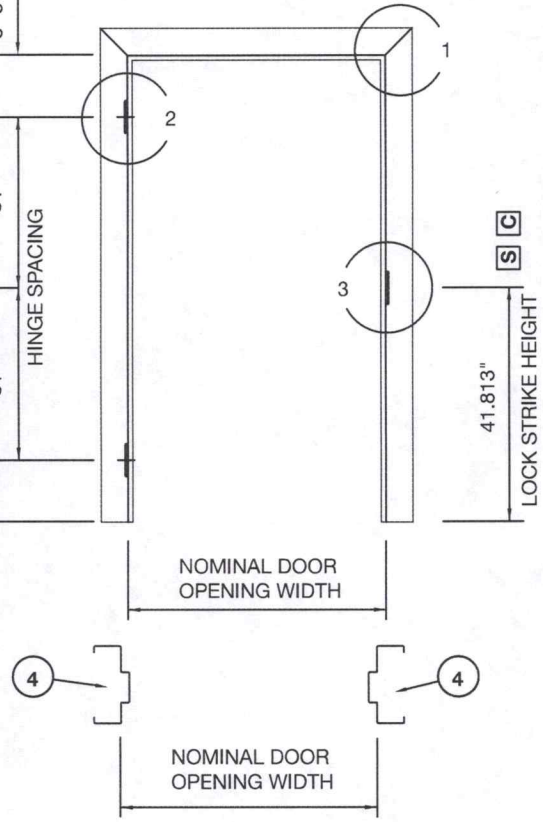

HORIZONTAL SECTION

JAMB ANCHOR QUANTITIES

2 PER JAMB FOR HEIGHTS 3'6" THRU 5'0" AND ONE FLOOR ANCHOR
3 PER JAMB FOR HEIGHTS >5'0" THRU 7'2" AND ONE FLOOR ANCHOR
4 PER JAMB FOR HEIGHTS >7'2" THRU 7'6" AND ONE FLOOR ANCHOR
5 PER JAMB FOR HEIGHTS >7'6" THRU 10'0" AND ONE FLOOR ANCHOR

ONE ADDITIONAL JAMB ANCHOR FOR EACH ADDITIONAL TWO FEET IN HEIGHT OR FRACTION THEREOF
ONE ADDITIONAL JAMB ANCHOR IN LIEU OF FLOOR ANCHOR FOR EXISTING STUDS AND/OR WALL CONDITIONS.

4 WIRE MASONRY ANCHOR WMA

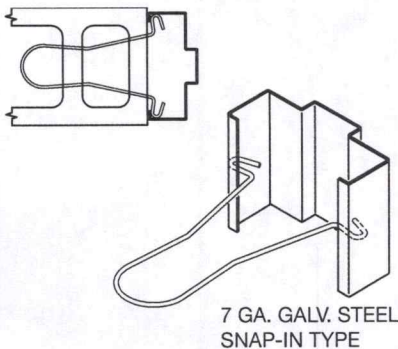

(FOR 3" THRU 8-3/4." DEPTHS)

4 MASONRY "T" ANCHOR (ADJUSTABLE) MT

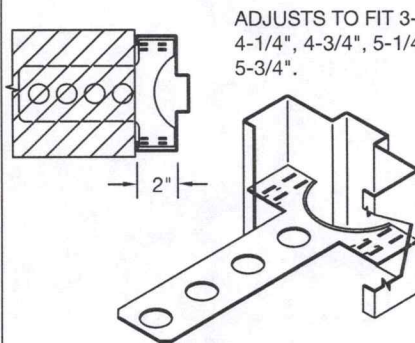

ALTERNATE MT ANCHOR DESIGN IS AVAILABLE FOR SPECIAL DEPTH & FACE FRAMES. SEE SECTION F13 FOR DETAILS.

4 EXISTING OPENING ANCHOR EO

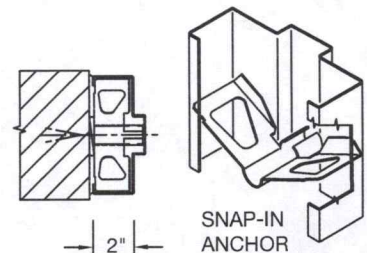

SU EO/S6: 4-3/4" THRU 6-3/4" DEPTH
PROFILE EO/S8: 6-7/8" THRU 8-3/4" DEPTH

10/18/19

(CONVERSION: 1" = 25.4 MM, E.G., 1-3/4" = 44.45 MM)



OregonDoor

we build the doors that build your reputation

Particleboard Core AWPC Series

5 PLY

| | |
|------------------------------|---|
| Thickness | 1-3/4" standard. 1-3/8" & 2-1/4" available upon request. |
| Maximum Sizes | NR: Single 4' x 10' Pairs 8' x 10' 20 Minute: Single 4' x 9' Pairs 8' x 9' |
| Core | NAF Particleboard core. ANSI A208 .1 , Grade LD-2. 32# Density |
| Stiles | Matching veneer or HPL, over (SCL) or compatible hardwood stile or solid hardwood matching stile available. |
| Rails | Structural Composite Lumber (SCL) optional oversize rails available |
| Faces | Domestic & exotic veneers, medium density overlay, HPL or 3-ply hardboard |
| Crossband | High Density Fiberboard (HDF) |
| Core Assembly | Stiles and rails are securely bonded to core and then entire unit is sanded prior to face veneer applied |
| Face Adhesive | Type 1 waterproof adhesive |
| Performance Standards | Meets or exceeds WDMA IS.1.A21 heavy duty & AWI edition 2, NAAWS 4.0 (Extra Heavy Duty performance achieved with use of blocking for surface hardware) |
| Fire Labeling | 20 minute positive pressure Cat. B standard construction on 1-3/4" or thicker door. Cat. A available. Subject to NFPA 252 and Intertek Testing Services |
| Factory Machining | Per hardware manufacturer's templates. Consult factory for special hardware requests. |
| Factory Finishing | WDMA TR-8 system 9 - UV acrylated polyurethane - clear, custom color matching, standard color selection, priming for field painting |
| Acoustic Rating | STC 29 or STC 30 when installed with appropriate gasketing. 1-3/4" only |
| Warranty | Interior use - Life of Installation. Exterior use - no warranty. See complete warranty for details. |
| Sustainability | CALGreen Compliant, LEED v4 Credit MR sourcing and EPD, EQ low emitting material and acoustic performance. CARB phase 2 (California Air Resources Board) compliant, TSCA Title VI, Extended Producer Responsibility Program- Take Back Program, Recycled Content and HPD. FSC 86% or 97% certification available when specified at time of order. LBC Declare label available - veneer face only. |





OregonDoor

we build the doors that build your reputation

Warranty Coverage

Architectural Series

| Construction | Interior Use | Exterior Use |
|----------------------------------|----------------------|--------------|
| Particleboard Core | Life of Installation | None |
| Agrifiber Core | Life of Installation | None |
| Structural Composite Lumber Core | Life of Installation | None |
| Mineral Core | Life of Installation | None |
| Acoustical (STC) Core | Life of Installation | None |
| Lead-Lined Core | Life of Installation | None |
| Bullet Resistant Core | Life of Installation | None |

Coverage

This warranty applies to purchasers of the below-described products from Oregon Door and to resale of them during the warranted time period, including transferees of the product. Oregon Door warrants that its products hereinafter listed, will be free from manufacturing defects which would render them unserviceable or unfit for the normal, recommended use for the time periods indicated above. Oregon Door is not responsible for damage or unsatisfactory performance caused by others.

No liability whatsoever shall be attached until the door(s) involved have been paid in full.

Prior to Installation

Any door made by Oregon Door found by an authorized representative of Oregon Door to be defective within the meaning of this warranty, prior to installation, will, at Oregon Door's option, except as provided hereof with respect to claims relating to door warp or telegraphing, either be repaired, or replaced with an identical Oregon Door product delivered to the location or the structure without charge. If, after a reasonable number of attempts to remedy the problem, repair or replacement is not practical, Oregon Door will refund the purchase price of the product.

Oregon Door does not guarantee safe delivery of goods; therefore, Oregon Door's responsibility for freight or handling damage ceases with the issuance of the bill of lading showing delivery in good order to the freight company. All claims for shortages, loss, or damage from any cause must be filed by the consignee upon the freight company.

After Installation

If any warranted door becomes defective after installation, Oregon Door will agree, in addition to the above, to pay

reasonable expenses for removing, rehangng, and refinishing. Such removal and rehangng shall be performed only with the approval of Oregon Door and after the cost of such work has been approved by Oregon Door. If the defect for which the product is being rejected was visible and apparent prior to installation, Oregon Door cannot be responsible for the cost of removal and reinstallation of the door.

Exceptions to Coverage

Oregon Door shall have no liability under this warranty unless such doors have been handled, stored, finished, installed and maintained in accordance with established building practices, WDMA recommendations, and the recommendations set forth in Oregon Door's written installation recommendations, and have been subject only to normal use. Normal wear and tear, including wear through of the finish is not considered to be a defect. Furthermore, unless the products have been prefinished by Oregon Door, Oregon Door shall have no liability under this warranty for the finish of such doors. This warranty does not apply if the defect or failure of the warranted door to conform to the warranty was caused by damage while in the possession of the consumer. Doors prefinished at the factory should be checked against an approved finish sample prior to hanging. **Installation of prefinished doors constitutes acceptance.** Oregon Door's sole responsibility is as stated in this warranty, and Oregon Door is not liable for consequential indirect or incidental damages. (This warranty gives you specific legal rights, and you may also have other rights that vary from state to state). Hollow core doors are not governed by this full warranty; rather, they carry a limited warranty for the duration noted above. Oregon Door FRP Rugged Series doors are covered by a separate warranty and are not governed by this warranty.

CONTINUED

Warranty Exclusions

1. Natural variation in color and texture of wood.
2. The appearance of field finished doors.
3. Fading or discoloration due to exposure from ultra-violet light sources. Materials such as tape being applied to finished doors can also affect the pre-finish and will be not be a valid warranty claim.
4. Normal wear and tear or deterioration for reasons other than material and workmanship of the door itself.
5. Unsatisfactory appearance or service caused by failure to follow recommended storage, handling, finishing, installation, proper care and maintenance instructions.
6. The warranty against warp will not apply to the following:
 - a. 1- $\frac{1}{2}$ " doors wider than 3-0 and taller than 7-0, or any door wider than 4-0
 - b. Doors that are improperly hung or do not swing freely
 - c. Doors, other than SCL (structural composite lumber) core doors, that have light and/or louver cutout area exceeding 40% of the door surface area or 50% of the door height
 - d. Doors that have been improperly stored or handled
 - e. Doors, other than SCL (structural composite lumber) core doors, that are installed as pocket doors
7. Doors, other than non-rated SCL (structural composite lumber) core doors, with light or louver cutouts closer than 5" to the door edge or doors with less than 5" between cutouts for lights, louvers, locks, closures and/or hardware cutouts.
8. Non-rated SCL (structural composite lumber) core doors with light or louver cutouts closer than 4" to the door edge or with less than 1- $\frac{1}{4}$ " between cutouts for lights, louvers, locks, closures and/or hardware cutouts.
9. Cracking of plastic laminate surface doors with openings not cut by Oregon Door personnel. A $\frac{1}{4}$ " radius at the corner of the openings must be maintained as specified by AWI 1300-S.
10. The appearance of high gloss on wood or plastic laminate doors.
11. Doors with different face materials on opposite sides of the door, such as veneers, plastic laminates, grain configurations, finishes, finish colors, etc. This exclusion will be waived when SCL (Structural Composite Lumber) core is used.
12. Incompatibility of hardware with a particular door construction.
13. Doors used in building exterior applications.
14. Defects in raw veneers not noticeable until after finishing such as, but not limited to, knife marks, glue bleed, veneer peel, or cracks in veneer.
15. Handling type damage, such as, but not limited to, scratches or dents, not reported within 30 days of delivery.
16. Doors with face grooving into or through cross bands.
17. The appearance of high sheen finish on painted, stained, or plastic laminate faced doors.
18. Doors with concealed closers deeper than 2" or wider than 1- $\frac{1}{4}$ " or machined pockets that leave less than $\frac{1}{4}$ " thick cavity walls.

Dimensional Tolerances

1. Stile, rail and core show-through (telegraphing) is not considered a defect unless the faces of the doors vary from a true plane in excess of $\frac{1}{100}$ " in any 3" span.
2. Size Tolerance: thickness $\pm \frac{1}{15}$ ", length $\pm \frac{1}{15}$ ", standard width $\pm \frac{1}{15}$ ", pre-fit width $\pm \frac{1}{32}$ "
3. Factory hardware preparation tolerance: $\pm \frac{1}{32}$ " on hinge preparation cutouts, + $\frac{1}{32}$ " minus 0 on lock front preparation cutouts.
4. Squareness tolerance: diagonal measurement difference will not exceed $\frac{1}{2}$ ".
5. Warp is any distortion in the door itself and does not refer to the door in relation to the frame or jamb in which it is installed. Warp is not considered a defect unless it exceeds $\frac{1}{4}$ " in the plane of the door itself. Warp is measured by placing a straightedge on the concave face and determining the maximum distance from the straightedge to the door face. For doors 1- $\frac{3}{4}$ " or thicker, warp will not exceed $\frac{1}{4}$ " in doors 3-6 x 7-0 or smaller, nor will it exceed $\frac{1}{4}$ " in any 3-6 x 7-0 section of larger doors. For doors 1- $\frac{3}{4}$ " in thickness, warp will not exceed $\frac{1}{4}$ " in 3-0 x 7-0 or smaller.

Claims Procedure

Claims should be processed through the intermediate suppliers (distributors). It is the responsibility of Oregon Door's intermediate suppliers to make the initial jobsite visit on a complaint to verify the issue and collect necessary documentation (i.e. photos, sizes, door numbers, etc.). On occasion, it may be necessary for Oregon Door to send a representative to the jobsite. If an Oregon Door representative is required to go to the jobsite and the issue is determined not to be a manufacturer's issue, then the intermediate supplier will be charged for all applicable expenses related to the jobsite visit.

Since Oregon Door cannot control the handling or exposure of doors after shipment, the purchaser must inspect the doors when received. Written notice of any claim must be given by the purchaser/installer to the intermediate supplier and to Oregon Door within 30 days of delivery. Forwarding of doors prior to inspection for damage will waive all opportunity to file a freight claim.

All parties must be given reasonable opportunity to investigate the reported issue and Oregon Door must be given reasonable opportunity to implement corrective action.

Purchaser _____
Project Name _____
Project Location _____
Product(s) Supplied _____
Order Number(s) _____
Date Shipped _____ Date Signed _____
By Void-Sample Only _____



OregonDoor
we build the doors that build your reputation

Care, Handling & Storage

Handling Doors

It is important to handle doors carefully. Handle doors like you would furniture.

Handle Oregon Door doors with clean canvas gloves. Bare hands leave finger marks and soil stains.

When moving doors, carry them. Never drag one door across another. Carts and other equipment used to handle doors must be padded.

Inspecting Doors

All doors must be inspected thoroughly by the installer before installation. Oregon Door's warranty does not cover doors installed with a defect that was obvious prior to installation. All doors should be inspected for freight damage upon receipt and before forwarding. Any observed damage must be noted on the delivery receipt. Notify Oregon Door immediately of any observed damage. Failure to follow this procedure may lead to claim denial by the shipper and/or carrier.

Door Tolerances

For information regarding maximum allowable tolerances on Oregon Door doors, please refer to the Oregon Door warranty.

Storing Doors

Oregon Door's shipping package is not intended for storage.

Stack doors flat on carefully leveled supports. We recommend a support of three 2 x 4's placed the full width of the doors, one across the center and one 12" from each end, covered with a sheet of plywood or heavy cardboard to protect the face of the bottom of the door. The top door should be covered in a similar manner. Keep doors clean and avoid discoloration by applying an opaque covering that does not permit light to penetrate. Covering must allow for air circulation. (Certain species including cherry, walnut and mahogany are extremely sensitive to light and require extra protection.)

Do not store doors in damp areas or in freshly plastered building. Storage space should be dry and well ventilated.

Doors should not be subjected to humidity under 25% or over 55%. Variations may cause permanent damage and will void the Oregon Door warranty.

Doors should be conditioned to the average humidity of the locality before hanging. The HVAC system should be operating and balanced prior to arrival of doors.

Field Finishing

Note: The Oregon Door warranty does not cover the appearance of field-finished doors.

Field-finished doors, including primed doors, must be sanded prior to finishing. Before finishing, place the door in a horizontal position. To remove raised grain or handling marks, block or power sand all surfaces with the grain. It is the responsibility of the field-finisher to determine the proper grit sandpaper required and the duration of face preparation necessary to make the appearance of the doors acceptable to the owner. Do not continue finishing if any issues arise.

The appearance of field-finished doors is the responsibility of the field-finisher. If applying a dark stain to a light wood, thorough initial sand-

ing is even more important to prevent blotchiness and to reduce the appearance of a "barber pole" effect. Do not use steel wool on oak doors.

Stains must be applied with the door in a horizontal position. This permits easier handling of the materials, and prevents the solvents from evaporating too rapidly. Rapid solvent evaporation can cause fillers to streak. It can also cause the wiping stains to dry before clean-up can be completed. If the door is in a horizontal position, premature drying is slowed down, since the heavier-than-air solvent vapors tend to remain on the surface. To stain/fill larger, flat areas quickly and with less danger of streaks, working in teams of two is recommended.

Good quality finishing materials used according to the manufacturer's directions provided will produce the best, most-durable results.

Door orders generally specify only species, grade and cut of veneer. Unless specified, no attempt is made to manufacture doors with flitches of similar color and grain. Finishing will accentuate any natural characteristics that are apparent prior to finishing.

Plastic Laminate Door Protectant

Many of our plastic laminate doors are supplied with a poly-peel coat on the door faces. The poly-peel coat protects the faces and should be peeled off after the door is installed.

Exterior Use

Oregon Door doors are not recommended and are not warranted for exterior use. If you must use a door in an exterior application, we recommend the use of structural composite lumber core (SCL) with medium density overlay (MDO) faces.

Fitting Doors

Jamb's should be plumb and square and doors should be hung so they will operate freely and without tension.

The recommended prefit in width is a minimum of $\frac{3}{16}$ " under and a maximum of $\frac{1}{4}$ " under to allow for no more than $\frac{1}{8}$ " clearance between the door edge and the frame at the hinge and lock side of the door.

The recommended prefit for clearance at the top of the door is $\frac{1}{8}$ ".

The net width of the door should always be measured from the widest face of the door.

We recommend beveling both edges at the rate of $\frac{1}{8}$ " in 2" so proper clearance can be maintained.

Fitting Non-Rated Doors

Stave Core, Particleboard Core, Structural Composite Lumber Core or Agrifiber Core doors

While it is best not to cut doors to fit openings smaller than those for which they were manufactured, the following guidelines should be followed when trimming is necessary.

Trim equally from both sides. You should first verify that the outer hardwood or softwood stile will allow for trimming of the amount that you are required to remove.

Doors with veneer or decorative laminate edgeband will require re-banding after trimming. It is not recommended that doors with veneered edges or laminate edge band be field trimmed.

If the total height must be reduced more than $\frac{3}{4}$ "; trim equally from the top and bottom, but never more than $\frac{3}{4}$ " from either end.

Care, Handling & Storage

Fitting & Installing Fire-Rated Doors

All fire-rated doors must be prefit and machined by Oregon Door or other licensed machiners. While it is best not to cut doors to fit openings smaller than those for which they are manufactured, licensed machiners may bevel the stiles at the rate of $\frac{1}{8}$ " in 2" so proper clearance can be maintained.

The standard location for Intertek Testing Service – Warnock Hersey (ITS-WH) and Underwriters Laboratories (UL) fire-rated door labels is on the hinge stile of the door. It identifies the door as fire-rated. Do not remove, cover up, or paint over the metal fire label. Do not trim the lock stile, hinge stile or top rail of doors with concealed intumescent. Doors may be undercut a maximum of $\frac{3}{4}$ " from the bottom only as long as clearances are maintained per NFPA-80.

Repair of Loose or Stripped Screws in Non-Combustible Stile Materials

The stile edge of positive pressure door constructions with non-combustible materials does not support screw reinsertion. If a door must be removed from an opening after the hinges are attached, avoid removing the hinge screws from the door edge. Instead, remove the hinge pins or remove the screws from the frame.

In situations where the hinge screws must be removed from the door stile after the hinges have been attached, it is recommended that wire or epoxy resin be inserted into the screw hole prior to reinserting the screws. For more details on this procedure, contact Oregon Door at 541.679.6791.

Lite & Louver Openings

Lite and louver openings in fire-rated doors must be machined at the factory or by an approved licensed machiner. For fire-rated labeling purposes, openings must be 5" to any edge and adjacent openings. For warranty purposes on particleboard core, agrifiber core, stave core and mineral core doors, openings must be 5" to any edge and adjacent openings.

For warranty purposes on structural composite lumber core doors, openings must be 2- $\frac{1}{8}$ " to any edge and adjacent openings. A minimum 5" top rail, 6" stiles and 12" bottom rail must be maintained.

Installing Non-Rated Wood Lite Kits

To properly install the glass in a wood lite kit, the glazier must first remove the packaged prefit pieces of the wood moulding kit from the plastic bag. It is the installer's responsibility to determine the type and amount of caulking or glazing tape required. The amount of caulking or glazing tape varies depending upon how much is needed to make the moulding fit flush on the door face. The loose moulding is nailed into place using 1- $\frac{1}{2}$ " nails (supplied by the installer), placed no more than 2" from the corners and no more than 8" apart. (Secure the narrow pieces of moulding first.) Set nails and fill holes with matching putty.

No-Bolt Blocking for Mineral Core Doors

Blocking is not standard in any mineral core door; blocking is available as an added option. When blocking is not specified, through bolts must be used to secure surface mounted hardware.

Installation Note: Surface mounted hardware should be anchored on the inner blocked door using the appropriate screw size that is supplied by the hardware manufacturer. It is important to pre-drill pilot holes for all screws used for hardware attachment per the hardware manufactures templates.

Failure to follow proper pre-drilling instructions for attachment of hardware with screws will void the door warranty and prohibit proper function of the hardware.

Refer to markings on the top rail for blocking options selected.

Door Frames

Install door frames per manufacturer's instructions. Do not install doors unless the jamb is plumb and square.

Consult the UL Building Materials Directory for listed frames.

Hardware

Care should be taken in fitting concealed hardware to ensure the door is not unduly weakened at that point.

Consult a factory representative if you have questions or concerns about hardware preparation.

Hinges

Mortise hinges should be pre-drilled for pilot holes (by the installer) and attached with wood screws per the hardware manufacturer's instructions. Surface hinges must be secured with steel through bolts.

Failure to pre-drill the hinges prior to screw attachment will cause the stile to split and void the door warranty.

Locks

Install locks per manufacturer's instructions.

Closers

A surface-type closer does not require the removal of wood except for fasteners. Some concealed closers may void warranty.

Surface-mounted hardware with through bolts can be used on mineral core doors without bolt blocking.

Backer plates are recommended on decorative laminate face and mineral core doors when throughbolts are used. Attach backer plates with No. 8 x $\frac{3}{4}$ " threaded-to-the-head wood screws. A pre-drilled $\frac{3}{32}$ " pilot hole is necessary.

When installing a closer, provide a properly located stop to limit the door opening swing and prevent stile and/or rail failure.

Metal Edge & Astragal

Metal edges or metal edges with astragal may be used on fire rated pairs (20, 45, 60 & 90 minute rated) but are not required except on mineral core doors (45, 60 & 90 minute rated) when concealed vertical rod panics are to be used.

Mineral core (45, 60 & 90 minute rated) pairs that are machined for concealed vertical rod panics require the use of 5" metal edge guards. Edge guards are not supplied by the door manufacturer unless specifically requested at the time of quote or ordering.

Proper prefit at the door width must be calculated to allow for the edge guard thickness.

Twenty-minute rated smoke doors require the use of fire retardant edges (FRE) at meeting stiles if metal edge guards are not being used.

Kickplates

Kickplates may be attached to the face of the door. The plate used must be an approved material (metal, stainless steel, acrylic, vinyl, bronze, aluminum, or high pressure laminate). The height from the bottom of the door is not to exceed:

- 48" for 20, 45, 60-minute rated doors (applied with screws or adhesive).
- 48" for 90-minute rated doors (applied with 6 x 32 nylon screws or adhesive only).
- 16" for 90-minute rated doors (applied with screws or adhesive).

If additional internal blocking is required for attachment with screws, you must consult the factory prior to manufacturing.

Maintenance

Make sure doors continue to swing freely (do not bind in the frame). Also, to ensure proper functioning, periodically inspect and adjust door hardware as needed.

Heading 02 (HwSet 02)

| | | | | Hand | Degree |
|---|------------------|------------------|-----------------|------|--------|
| | | | | Act | InAct |
| 1 | SGL DOOR(S) 301A | KINDERGARTEN 303 | FROM BOYS 301 | LHR | |
| 1 | SGL DOOR(S) 302A | KINDERGARTEN 303 | FROM GIRLS 302A | RHR | |
| 1 | SGL DOOR(S) 404A | KINDERGARTEN 401 | FROM TOILET 404 | LHR | |

3'0" x 6'8" x 1-3/4" x WD x HMF x

Totals

Each Assembly to have:

| | | | | | |
|------|---|--------------|-------------------------|-----|-----|
| (9) | 3 | EA HINGES | T4A3386 4-1/2" X 4-1/2" | 626 | MCK |
| (3) | 1 | EA PASSAGE | AU5401LN | 626 | YAL |
| (3) | 1 | EA KICKPLATE | 8400 10" X 34" | 630 | IVE |
| (3) | 1 | EA MOP PLATE | 8400 4" X 35" | 630 | IVE |
| (3) | 1 | EA WALL STOP | WS401 | 626 | IVE |
| (9) | 3 | EA SILENCER | SR64 | GRY | IVE |

Heading 03 (HwSet 03)

| | | | | Hand | Degree |
|---|------------------|------------------|------------------|------|--------|
| | | | | Act | InAct |
| 1 | SGL DOOR(S) 304A | KINDERGARTEN 303 | FROM STORAGE 304 | RHR | |
| 1 | SGL DOOR(S) 402A | KINDERGARTEN 401 | FROM OFFICE 402 | RHR | |

3'0" x 6'8" x 1-3/4" x WD x HMF x

Totals

Each Assembly to have:

| | | | | | |
|------|---|--------------|-------------------------|-----|-----|
| (6) | 3 | EA HINGES | T4A3386 4-1/2" X 4-1/2" | 626 | MCK |
| (2) | 1 | EA LOCKSET | AU5407LN X 1210 | 626 | YAL |
| (2) | 1 | EA KICKPLATE | 8400 10" X 34" | 630 | IVE |
| (2) | 1 | EA WALL STOP | WS401 | 626 | IVE |
| (6) | 3 | EA SILENCER | SR64 | GRY | IVE |

| | | | |
|--|------------------|-------------------------|---------------------|
| Project : FRANKLIN ELEMENTARY SCHOOL MODERNIZATION | Control # : 2252 | Print Date : 06/01/2026 | Project # : |
| Supplier : CHAMPION HARDWARE, INC. | Revision # : | Rev Date : | Hdwe Sched Page : 1 |

Heading 04 (HwSet 04)

1 SGL DOOR(S) 403A OFFICE 402 FROM TOILET 403

Hand Degree
LHR Act InAct

3'0" x 6'8" x 1-3/4" x WD x HMF x

Totals

Each Assembly to have:

| | | | | | | |
|------|---|----|-----------|-------------------------|-----|-----|
| (3) | 3 | EA | HINGES | T4A3386 4-1/2" X 4-1/2" | 626 | MCK |
| (1) | 1 | EA | LOCKSET | AU5402LN | 626 | YAL |
| (1) | 1 | EA | CLOSER | 7500 | AL | NOR |
| (1) | 1 | EA | KICKPLATE | 8400 10" X 34" | 630 | IVE |
| (1) | 1 | EA | MOP PLATE | 8400 4" X 35" | 630 | IVE |
| (1) | 1 | EA | WALL STOP | WS401 | 626 | IVE |
| (3) | 3 | EA | SILENCER | SR64 | GRY | IVE |

Heading 08 (HwSet 08)

1 SGL DOOR(S) 405A KINDERGARTEN 401 FROM TOILET 405

Hand Degree
RHR Act InAct

3'0" x 6'8" x 1-3/4" x WD x HMF x

Totals

Each Assembly to have:

| | | | | | | |
|------|---|----|-----------|-------------------------|-----|-----|
| (3) | 3 | EA | HINGES | T4A3386 4-1/2" X 4-1/2" | 626 | MCK |
| (1) | 1 | EA | PASSAGE | AU5401LN | 626 | YAL |
| (1) | 1 | EA | KICKPLATE | 8400 10" X 34" | 630 | IVE |
| (1) | 1 | EA | MOP PLATE | 8400 4" X 35" | 630 | IVE |
| (1) | 1 | EA | DOME STOP | FS438 | 626 | IVE |
| (3) | 3 | EA | SILENCER | SR64 | GRY | IVE |

| | | | |
|--|------------------|-------------------------|---------------------|
| Project : FRANKLIN ELEMENTARY SCHOOL MODERNIZATION | Control # : 2252 | Print Date : 06/01/2026 | Project # : |
| Supplier : CHAMPION HARDWARE, INC. | Revision # : | Rev Date : | Hdwe Sched Page : 2 |

CUT SHEET

McKinney T4A3386

Five Knuckle Heavy Weight Hinge

McKinney

ASSA ABLOY

Experience a safer
and more open world

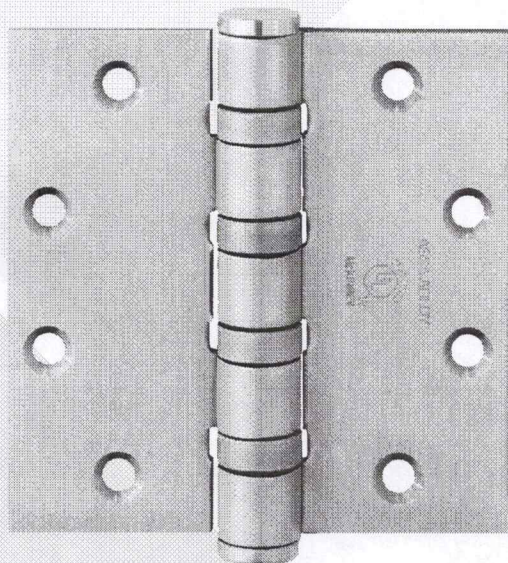

SPECIFICATIONS:

MATERIAL:

Stainless

DESCRIPTION:

Five Knuckle Heavy
Weight Hinge

FASTENERS:

- (8) 1/2" x #12-24 Machine Screws
- (8) 1 1/4" x #12 Wood Screws

OPTIONS:

- NRP-Non-Removable Pin
- TB-Ball Bearing
- TCA-Concealed Bearing
- RC-Round Corner - 1/4" radius furnished unless specified otherwise
- HT-Hospital Tip
- BT-Ball Tip
- FT-Flat Tip
- ST-Steeple Tip
- SSF-Safety Stud Feature
- RB-Raised Barrel
- QC-4, 8, or 12 wire available
- CC-4, 8, or 12 wire available
- CC-18-2, 4, 6, 8, or 10 wire available (2-18AWG wires and the remainder 28AWG wires)
- MM-Magnetic Monitoring

SIZE:

4 1/2" x 4"

AVAILABLE FINISHES:

- US32D/630

PACKAGED/WEIGHT:

- 3 ea Per Box
- 24 ea Per Case
- Case Weight-37 lbs

UL/ANSI:

NFPA 80 UL Openings
A5111 Grade 1

BENEFITS & FEATURES

Benefits

- **Heavy-Duty:** Rugged Grade 1 construction offers greater reliability and resists wear-and-tear
- **Secure:** Innovative features protect against damage and vandalism
- **Versatile:** Range of functions and options offer an ideal solution for a variety of commercial applications
- **Easy installation:** Adjustable rose allows for easy adjustment on different door thicknesses
- **Strong & Reliable:** ANSI/BHMA Grade 1 certification for long-life and durability

Features

- Heavy duty construction features wear-resistant chassis plates, longer thread-locking thrubolts, heavy-duty lever return springs and stainless steel latchbolt for exceptional strength and durability
- Free Wheeling lever mechanism prevents vandalism and reduces maintenance
- Adjustable rose support plates
- Available in 3 lever designs, 24 functions (including electrified) and 10 standard finishes
- ANSI/BHMA Certified Grade 1
- ADA compliant for ease of accessibility

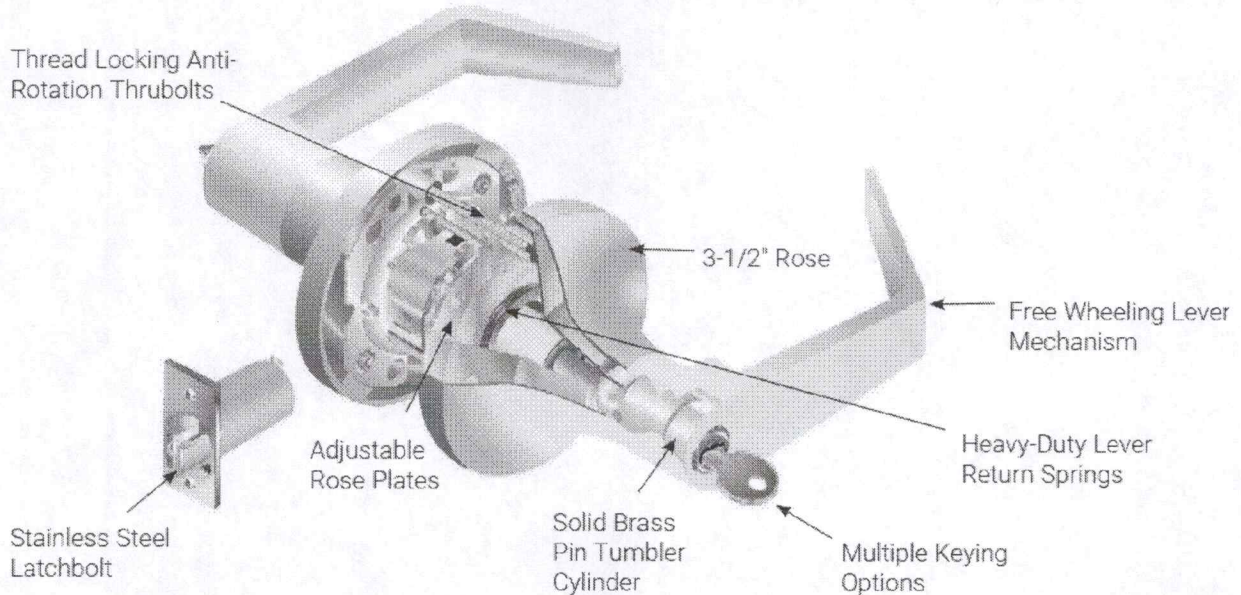

Specifications

| | |
|-----------------------|---|
| Backset | 2-3/4" standard, 3-3/4" optional |
| Door Thickness | Adjustable for doors 1-3/4" to 2" |
| Handing | Non-handed, field reversible |
| Latchbolt | 2-3/4" backset, 1/2" throw. See page 14 for additional options. |
| Strike | ANSI strike 4-7/8" x 1-1/4" x 1-1/4" lip to center. See page 15 for additional options. |
| ANSI/BHMA | Certified Grade 1, ANSI/BHMA A156.2 |
| UL/cUL | Listed for 3 hour fire doors |
| Windstorm | Certified, check local codes. |
| Warranty | 7 years |

5400LN Series Grade 1 Cylindrical Lever Locks

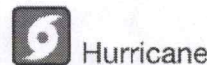

Copyright © 2002-2026, ASSA ABLOY Access and Egress Hardware Group, Inc. All rights reserved. Reproduction in whole or in part without the express written permission of ASSA ABLOY Access and Egress Hardware Group, Inc. is prohibited. Patent pending and/or patents: www.assaabloy.com/patents.

FINISHES

| ANSI/BHMA Code Finish Description | | | | |
|--|--|--|--|--|
| 605 Bright Brass, Clear Coated | 606 Satin Brass, Clear Coated | 612 Satin Bronze, Clear Coated | 613E Dark Oxidized Satin Bronze - equivalent | 619* Satin Nickel Plated, Clear Coated |
|  |  |  |  |  |
| 625 Bright Chrome Plated | 626* Satin Chrome Plated | 693 Black Painted | BSP Black Suede Powder Coat | WSP White Suede Powder Coat |
|  |  |  |  |  |

613 and 722 finishes available by Special Product Request only. Please contact Customer Service for additional information.

*Finish available with MicroShield® antimicrobial coating, additional finishes by special application. Consult factory for availability.

MicroShield coating may vary finish color from architectural standards. MicroShield is not intended as a substitute for traditional infection control programs such as hand hygiene or use of disinfectants. Coated products must still be cleaned to ensure the surfaces will be free of destructive microbes. ASSA ABLOY ACCENTRA® makes no representations or warranties, express or implied, as to the efficacy of MicroShield.

LEVER TRIM

Augusta AU

Lever: Cast Zinc
Rose: Wrought Brass

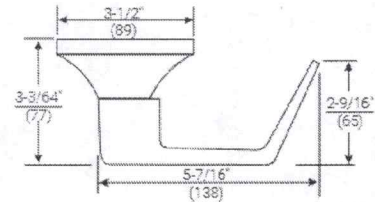
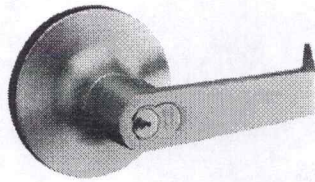
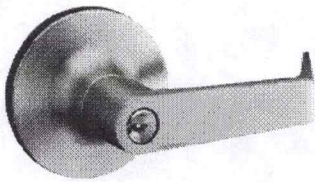

Monroe MO

Lever: Cast Zinc
Rose: Wrought Brass

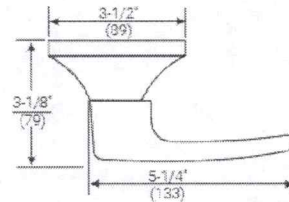
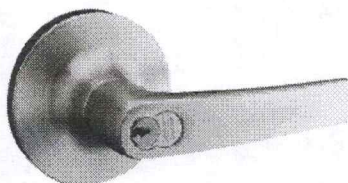
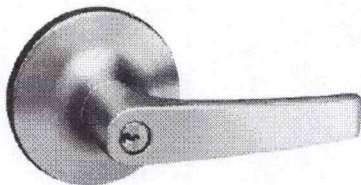

Pacific Beach PB

Lever: Cast Zinc
Rose: Wrought Brass

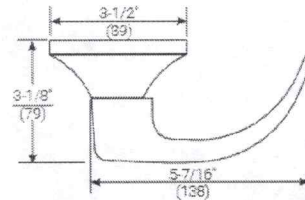
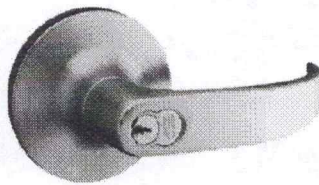
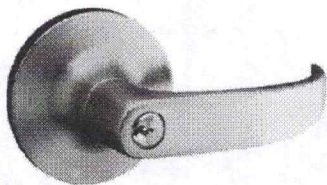

Available with large and small format interchangeable core. See page 12-13 for details.

Dimensions shown are in inches/mm.

6 Copyright © 2002-2026, ASSA ABLOY Access and Egress Hardware Group, Inc. All rights reserved. Reproduction in whole or in part without the express written permission of ASSA ABLOY Access and Egress Hardware Group, Inc. is prohibited. Patent pending and/or patent www.assaabloydea.com/patents.

FUNCTIONS

| 5401LN (F75) | 5402LN (F76A) | 5403LN (F77A) |
|--|---|--|
| <p>Passage or Closet Latch</p> <ul style="list-style-type: none"> For doors that do not require locking. Either lever operates latchbolt at all times.  <p style="text-align: center;">Outside Inside</p> | <p>Privacy, Bedroom or Bath Lock</p> <ul style="list-style-type: none"> For lavatory or other privacy doors. Either lever operates latchbolt unless outside lever is locked by pushbutton inside.* Button automatically releases when inside lever is turned or door is closed. Emergency release in outside lever. Emergency key supplied. (PN 14-5302-1053-048) Inside lever always active.  <p style="text-align: center;">Outside Inside</p> | <p>Patio or Privacy Lock</p> <ul style="list-style-type: none"> For exit doors with limited entry. Deadlocking latchbolt. Either lever operates latchbolt unless outside lever is locked by pushbutton inside.* Button automatically releases when inside lever is turned or door is closed. Inside lever always active.  <p style="text-align: center;">Outside Inside</p> |
| 5404LN (F82A) | 5405LN (F86) | 5406LN (F92) |
| <p>Entry Lock</p> <ul style="list-style-type: none"> For entrance or office doors. Deadlocking latchbolt. Either lever operates latchbolt (except when outside lever is locked from inside).* Pushing button in inside lever locks outside lever. (Automatically releases when inside lever is turned or key is rotated in locked outside lever.) Latchbolt is operated by key in outside lever or by rotating inside lever. Inside lever always active.  <p style="text-align: center;">Outside Inside</p> | <p>Storeroom or Closet Lock</p> <ul style="list-style-type: none"> For use on storeroom, utility, and exit doors. Deadlocking latchbolt. Latchbolt operated by lever inside, key in outside lever. Outside lever always locked.* Inside lever always active.  <p style="text-align: center;">Outside Inside</p> | <p>Service Station Lock</p> <ul style="list-style-type: none"> Deadlocking latchbolt. Either lever operates latchbolt. Pushbutton in inside lever locks outside lever. (Automatically releases when inside lever is turned, door is closed or key is rotated in outside lever, except when slotted pushbutton is rotated 90° clockwise to retain outside lever in locked position).* Latchbolt operated by key in outside lever, inside lever always active.  <p style="text-align: center;">Outside Inside</p> |

*Lever handles are Free Wheeling in locked position. Shaded area denotes Free Wheeling lever.

FUNCTIONS

| 5407LN (F109) | 5408LN (F84) | 5409LN (F89) |
|--|---|---|
| <p>Entry Lock</p> <ul style="list-style-type: none"> For entrance, general home or office doors. Deadlocking latchbolt. Either lever operates latchbolt (except when outside lever is locked from inside).* Pushing turn button in inside lever locks outside lever, and automatically releases when inside lever is turned or key is rotated in locked outside lever. Outside lever may be retained in locked position by pushing and rotating turn button 90° clockwise to a horizontal position; not released until turn button is manually returned to the vertical position. Latchbolt is operated by key in outside lever or by rotating inside lever. Inside lever always active.  <p style="text-align: center;">Outside Inside</p> | <p>Classroom Lock</p> <ul style="list-style-type: none"> For classroom or utility room doors. Deadlocking latchbolt. Either lever operates latchbolt (except when outside lever is locked by key).* Inside lever always active. Outside lever locked* or unlocked only by key.  <p style="text-align: center;">Outside Inside</p> | <p>Exit Latch</p> <ul style="list-style-type: none"> For exit doors with no-entry desired. Deadlocking latchbolt. Outside lever always locked.* Inside lever always active.  <p style="text-align: center;">Outside Inside</p> |
| 5417LN (F88) | 5418LN (F110) | 5421LN (F80) |
| <p>Apartment, Exit or Public Toilet Lock</p> <ul style="list-style-type: none"> For office or apartment building entrance doors or lavatory doors. Deadlocking latchbolt. Either lever operates latchbolt (except when outside lever is locked by key from inside).* Key in outside lever operates latchbolt. Inside lever always active. <p>NOTE: Inside handle requires 1802S standard 6-pin cylinder.</p>  <p style="text-align: center;">Outside Inside</p> | <p>Intruder Classroom Lock</p> <ul style="list-style-type: none"> For classroom doors. Deadlocking latchbolt. Either lever operates latchbolt (except when outside lever is locked by key from either side). Outside lever remains locked upon egress. Inside lever always active.  <p style="text-align: center;">Outside Inside</p> | <p>Communicating Lock</p> <ul style="list-style-type: none"> For communicating or store entrance doors. Deadlocking latchbolt. Either lever operates latchbolt (except when key in either lever locks or unlocks the lever independently of the other).* Should be used only in offices or rooms with multiple entries. <p>NOTE: Not available with IC core cylinders.</p>  <p style="text-align: center;">Outside Inside</p> |



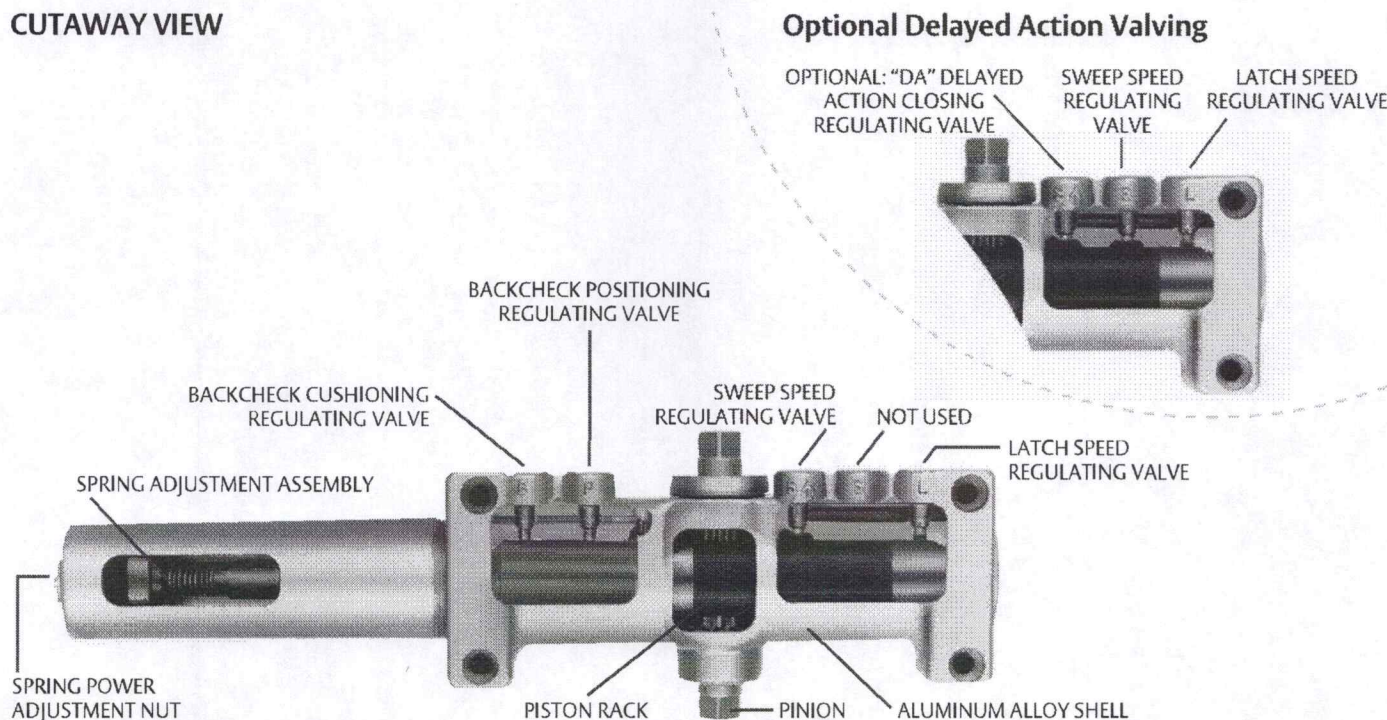

*Lever handles are Free Wheeling in locked position.
Shaded area denotes Free Wheeling lever.

7500 SERIES INSTITUTIONAL DOOR CLOSER

OVERVIEW CUTAWAY VIEW



CERTIFICATIONS

- » ANSI/BHMA A156.4, Grade 1 certified 
- » UL / cUL listed for use on fire rated doors 
- » UL10C listed for positive pressure fire test
- » 7500 door closers are designed to comply with requirements for the Americans with Disabilities Act (A.D.A) and ANSI standard A117.1 
- » This product is manufactured in an ISO 9001, ISO 14001 facility
- » Health product declaration and UL certified environmental product declaration
- » GreenCircle certified environmental facts 

CAUTION: Door Closers for Low Opening Force Applications:

Door closers installed in openings required to meet the requirements of the Americans With Disabilities Act or ANSI/BHMA Standard A117.1, when adjusted to meet those requirements, may not provide adequate closing power to dependably close and latch the door based on opening or site conditions.



An Environmental Product Declaration (EPD) documents the cradle-to-grave life cycle of a product and how it affects the environment. An important aspect of EPD® is to provide the basis of a fair comparison of products and services by its environmental performance. EPDs can reflect the continuous environmental improvement of products and services over time and are able to communicate and add up relevant environmental information along a product's supply chain.

Windstorm

Norton 7500 door closers are UL certified for inswing and outswing single and pair (up to 8'0" x 8'0") door assemblies to ICC 500 for Storm Shelters. Additionally, the 7500 meets FEMA 361 guidelines. 7500 is part of a complete ASSA ABLOY tornado and hurricane shelter solutions utilizing Ceco StormPro 361, Curries StormPro 361, Fleming F5 doors and frames and McKinney SP hinges.

EXPLANATION OF FEATURES

Aluminum Alloy Housing

Closer bodies are constructed of a special aluminum alloy, carefully selected to accommodate interactive steel components and operating conditions.

Rack & Pinion Operation

Provides a smooth constant control of the door through its full opening and closing cycle. 180° door swing can be achieved when door, frame, hardware and arm function do not interfere.

Non-handed

With few exceptions all series 7500 door closers are non-handed and can be installed on either right or left hand swing doors. Pinion shaft extends vertically through the closer body in both directions. Some options will require that the hand of the closer be specified.

Sweep Speed Control Valve

Allows adjustment of door speed from the door's full open position down to approximately 10° from the closed position.

Latch Speed Control Valve

Allows adjustment of door speed from approximately 10° down to the door's fully closed position.

Tri-Style® Packing

7500 comes with screws, brackets and soffit plates to allow for regular, top jamb, and parallel arm installations.

Adjustable Backcheck Cushion Valve

Provides control of the door in the opening cycle, beginning at approximately 75° of door opening. It slows/cushions the door opening, when the door is forcibly opened beyond its pre-adjusted limits.

Adjustable Backcheck Position Valve

Allows the door opening position, where backcheck cushioning begins,

to be adjusted to a greater door angle, up to a maximum of 20° farther (approximately 95°).

Standard Molded Cover

Molded of high-impact U.L. listed material and covers the entire closer body assembly. This cover is non-handed for all applications.

Warranty

These closers carry a limited 30-year warranty against defect, and life of the building on the aluminum housing.

Closer Fluid

NorGlide® closer fluid is a specially formulated multi-viscosity hydraulic fluid that contains lubricity and anti-oxidation agents that provide optimum performance and efficiency. This fluid complements the interaction of the door closer's aluminum housing with its steel and brass components, while maintaining stable viscosity to allow the door closer to perform in temperatures ranging from extremely high to as low as -40° F.

Door Closer Power Options

Series 7500 Multi-Sized Door Closer

Adjustable through the entire power range of door closer sizes 1 through 6, as outlined in ANSI/BHMA standard A156.4.

The series 7500 also conforms to the minimum opening force requirements of the Americans with Disabilities Act (A.D.A.) and ANSI/BHMA standard A117.1 for interior doors.

Extra Power

For applications that require additional closing power to overcome stack pressure, high wind, unbalanced HVAC and other issues that can prevent the doors from closing, model 7706EP is available.

Model 7706EP offers as much as 22 lbs. of closing force (not adjustable,

arm mounting (RA, TJ or PA) and degree of swing determine the exact lbs.) Non-ADA doors only.

Corrosion-Resistant Door Closer

The series 7500SS door closers with molded plastic cover are available for use where corrosive conditions exist. This series is provided with brass adjustment valves, a 440 grade stainless steel pinion shaft, an all-aluminum body and bronze closer arm bushings; all other components are of 302/303 grade stainless steel. Fasteners are 8-18 stainless steel. This product is available for standard regular arm, top jamb and parallel arm, non-hold open, applications only.

Optional Metal Cover

This steel cover is non-handed for regular and parallel arm applications, but is handed for top jamb applications. Cover is available in sprayed or architectural plated finishes.

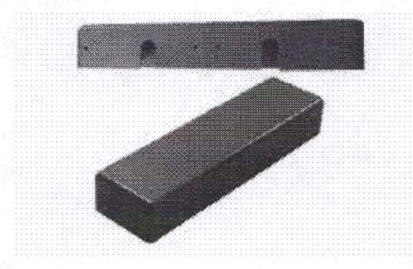

Security Cover

Supplied standard with all series 7570 door closers. This deep drawn steel cover is handed for all applications. The cover is fastened to the closer body at two points on top and to the door closer body stand-offs at two points on the bottom.

Optional ABS Cover

Consult factory for details.

EXPLANATION OF FEATURES

Enhanced Backcheck

This feature provides adjustable backcheck intensity beginning at approximately 15° of the door opening cycle. It is intended for use in situations where the standard backcheck beginning at approximately 75° of door opening allows too much unrestricted door travel to obtain control of the door without the fear of peripheral damage to the door closer, door, frame, hinges or pivots; or adjacent walls or structures. This feature is most frequently used in schools and detention facilities. Specify suffix EBC.

Adjustable Delayed Action Closing

An optional hydraulic feature that adds a third speed range to the closing cycle. This feature becomes effective when the door is opened and released at any point beyond 70°. The amount of time delay depends upon the combination of the angle of door release and valve adjustment. The valve can be adjusted with a 1/8" (3mm) hex key from no delay time up to maximum delay times of:

| Door Opened and Released at | Approximate Time of Delay Cycle |
|-----------------------------|---------------------------------|
| 180° | 4-5 minutes |
| 120° | 2-3 minutes |
| 90° | 25-30 seconds |

Pressure Relief Safety Valve

The delayed action hydraulic system contains a pressure relief valve. Any time the door is forced toward the closed direction while it is in the closing cycle, the valve will open and permit the door to close. This prevents damage to door, frame and closer.

Suggested Applications

Delayed Action closing allows slow-moving traffic to clear the opening before the door closer's normal

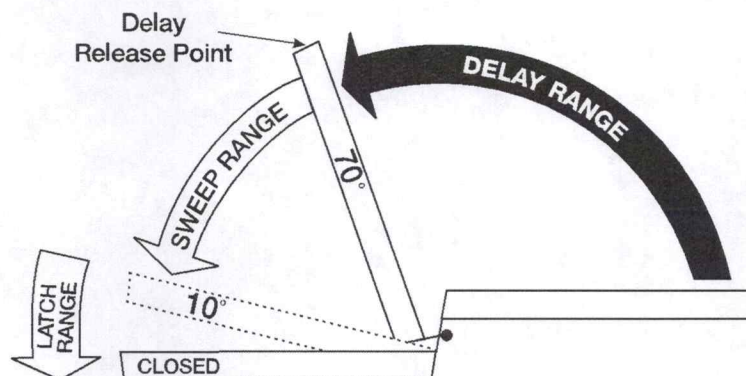

closing cycle begins. This feature can be helpful in health care facilities such as hospitals and nursing homes. It provides sufficient time for persons on crutches or in wheelchairs to pass through a door without concern of it closing. At the same time, it can accommodate the facility's staff with movement of food service carts, beds, and other wheeled traffic.

Use of delayed action closers on many doors throughout industrial and commercial buildings can also assist the flow of traffic. Locations where additional time to clear the opening is advantageous are doors between office and factory/warehouse facilities, doors to workshops or laboratories, to kitchen and food processing areas, etc.

OPTIONAL FEATURES – ARMS

Non-Hold Open

Self-closes door every time door is opened. Auxiliary stop (by others) required except when using the CloserPlus®, CloserPlus Spring™ or Unitrol® arms.

Hold Open

Achieved by means of ball and detent/roller. Ball and detent or roller hold open is effective in a range of 85° to 110°.

Hold open arm door closers are not permitted to be used on fire door assemblies.

Door Opening Degrees

| Arm Function | Regular Top Jamb Parallel Arm | Parallel Rigid Arm | CloserPlus® Parallel Arm | CloserPlus Spring™ Parallel Arm | Unitrol® Parallel Arm | Unitrol® Top Jamb | Low Profile Regular, Parallel | Slide Track |
|---------------|-------------------------------|--------------------|--------------------------|---------------------------------|-----------------------|-------------------|-------------------------------|------------------|
| Non-Hold Open | ✓ | ✓ | 85° to 110° | 85° to 110° | 85° to 110° | 85° to 110° | ✓ | 85° to 110°/180° |
| Hold Open | 90° to 180° | 85° to 180° | 85° to 110° | 85° to 110° | 85° to 180° | 85° to 180° | ✓ | 85° to 110° |

✓=180° trim and template permitting

SUGGESTED SPECIFICATIONS

7500 Series

Closers for interior and exterior doors shall be full rack-and-pinion type with cast aluminum alloy body. Closers shall be surface mounted and shall project no more than 2-3/16" (55mm) from the surface of the door. Closers shall be non-handed to permit installation on doors of either hand. Closer fluid shall contain lubricity and anti-oxidation agents. Closer fluid shall maintain stable viscosity to allow door closer to perform in temperatures ranging from extremely high to as low as -40°F. Closers shall have multi-size spring power adjustment to permit setting of spring from size 1 through size 6. Closers shall have two non-critical valves, hex key adjusted, to independently regulate sweep speed and latch speed.

Closers shall have backcheck cushioning controlled by a hex key adjusted valve. Closers shall have backcheck position controlled by a hex key adjusted valve.

[Closers shall have adjustable delayed-action closing controlled by a hex key adjustable valve.]

[Closers shall be highly corrosion resistant and shall have all external body components of aluminum, brass or stainless steel material and all fasteners of stainless steel.]

Regular arm and top jamb closers shall have a non-hold open shoe permitting 15% (+/- 7-1/2%) power adjustment. **Closers shall be enclosed in a [molded resin cover] [plated or sprayed metal cover]. Closers to be Norton [7500] [7500M] [7500SS].

**For special arms insert the appropriate specification from column three on this page.

**Unitrol® Arm

Door closers shall have a fixed door stop feature effective at one point selected at installation, from 85° - 110° in five-degree increments. Door stop shall be cushioned by a shock-absorbing heavy-duty spring action effective at the [soffit plate] [arm shoe] pivot. [Closers shall be provided for parallel arm installation using rigid steel main arm and secondary arm lengths proportional to the door width.] [Closers shall be provided for top jamb installation using steel, rigid main arm and telescoping secondary arm adequate for the frame reveal of the openings.]

**CloserPlus® Arm

Door closers shall have a field reversible door stop. Hold open tension shall be adjustable effective at one point selected at installation, from 85° - 110° in five degree increments. Closers shall be provided for parallel arm installation using a forged rigid steel main arm and secondary arm.

**CloserPlus Spring™ Arm

Door closers shall have built-in door stop [and holder] effective at one point selected at installation, from 85° - 110° in five-degree increments. Door stop mechanism shall be reversible and have a buffer spring that engages prior to the dead stop feature, reducing shock loads to the door and frame assembly. Door stop mechanism shall be attached to soffit plate. [Hold open mechanism shall have engage/disengage selection actuated by thumbturn]. Closers shall be provided for parallel installation using a forged rigid steel main arm and secondary arm.

APPLICATIONS

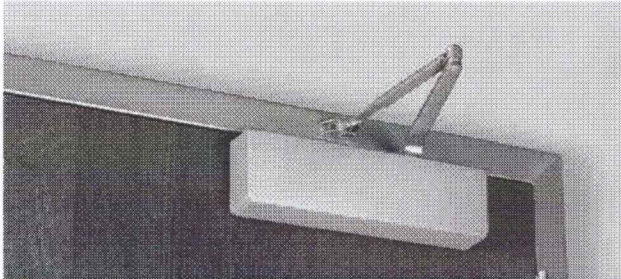

Non-hold open arm shown

Regular Arm

This is the only pull-side application where a double lever arm is used. It is the most power efficient application for a door closer. Sufficient frame, door and/or ceiling clearance must be considered.

Since the arm assembly projects directly out from the frame, this application may present an aesthetics issue or be prone to vandalism.

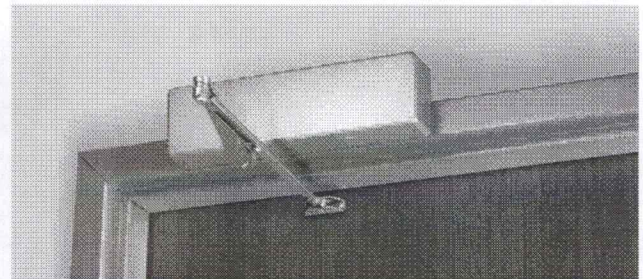

Non-hold open arm shown

Top Jamb

For efficiency reasons this application provides the best alternative to the regular arm application. There must be sufficient frame face and/or ceiling clearance for this application. It requires a top rail on the door of just 2-1/8" (54mm). This application provides the best door control for doors in exterior walls that swing out of a building.

The entire door closer and arm assembly project from the frame, similar to the regular arm application, where matters of appearance and malicious abuse can be of concern. Consideration must be given to depth of frame reveal.

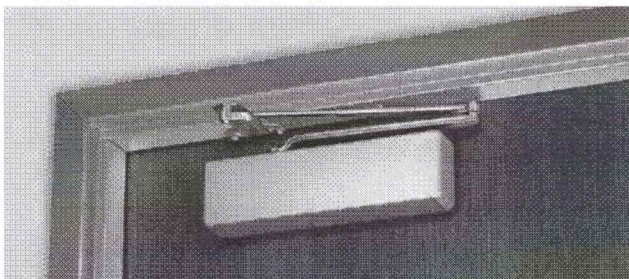

Parallel Arm

This application provides the most appealing design appearance for a surface-mounted door closer having a double lever arm. This also makes it beneficial in vandalism-prone areas. It is on the push side of the door and the arm assembly extends almost parallel to the door. In the closed position, there is very little or no hardware projecting beyond the frame face in most situations.

Due to the geometry of the arm it is approximately 25% less power-efficient than a regular arm application. The entire closer and arm assembly are mounted below the frame stop, requiring a top rail clearance on the door of between 6-5/8" (168mm), when using a low profile arm, to 7-1/4" (184mm), when using the hold open arm.

7500 SERIES INSTITUTIONAL DOOR CLOSER

REGULAR ARM

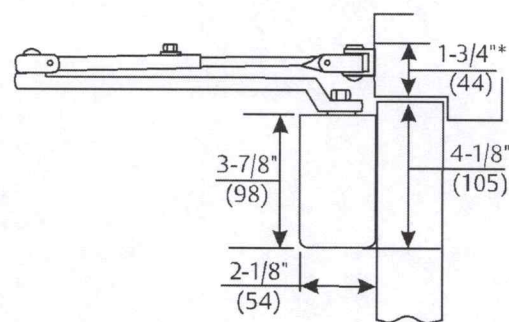
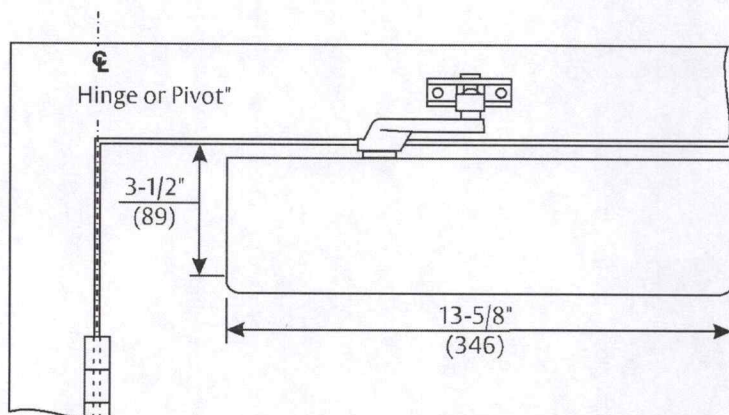

Mounting holes for closer body are spaced 2-3/8" (60mm) vertically x 6-3/4" (171mm) horizontally.
* This dimension will vary. Standard non-hold open arm illustrated.

| Model Number | |
|---------------|-----------|
| Non-Hold Open | Hold Open |
| 7500 | 7500H |

Notes:

- » Door closers are set at midpower range from the factory
- » Measurements are inches/mm unless noted
- » Standard door widths: interior 32"-54" (81-137cm)
exterior 30"-48" (76-122cm)

TOP JAMB ARM

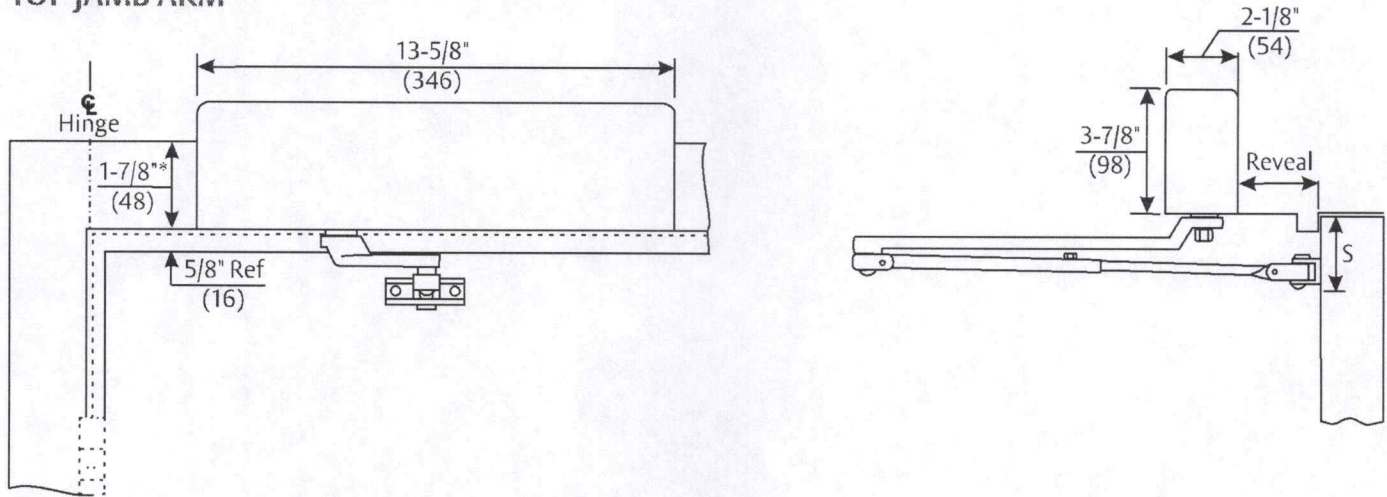

Mounting holes for closer body are spaced 2-3/8" (86mm) vertically x 6-3/4" (171mm) horizontally.
 * Minimum frame face with 7786 drop plate. 3-1/4" (83mm) required when drop plate is not used.

| Maximum Door Width Inches (cm) | Reveal Range Inches | Maximum Door Opening |
|--------------------------------|-----------------------------------|----------------------|
| Multi-Sized | Non-Hold Open Arm | |
| (J5)7500/7500M | 0" to 3" (0 to 76mm) | 180° |
| J7500 | 2-3/4" to 7" (70 to 178mm) | 150° |
| JL7500 | 2-3/4" to 7" (70 to 178mm) | 180° |
| J7580 x 7787 | 0" to 2-3/4" (0 to 70mm) | 180° |
| Multi-Sized | Hold Open Arm | |
| J7500/J7530MH | 0" to 3" (0 to 76mm) | 180° |
| J7500H | 2-3/4" to 6-3/4" (70 to 171mm) | 150° |
| JL7500H | 2-3/4" to 6-3/4" (70 to 171mm) | 180° |

| Model Number | |
|---------------|-----------|
| Non-Hold Open | Hold Open |
| 7500 | 7500H |
| J7500 | J7500H |
| JL7500 | JL7500H |

Notes:

- » Door closers are set at midpower range from the factory
- » Measurements are inches/mm unless noted
- » Standard door widths: interior 32"-54" (81-137cm)
 exterior 30"-48" (76-122cm)

| S Minimum Top Rail of Door | | | | | |
|---|------------------------------|-------|---------------------------|------------------------------|------------------|
| Without Drop Plate or with 7786 Back Plate (mm) | | | With 7787 Drop Plate (mm) | | |
| J7500/ J7530M J7500 | J7500H/ J7530MH J7500H | J7580 | J7500/ J7530M J7500 | J7500H/ J7530MH J7500H | J7580 |
| 2" (51mm) | 2-1/2" (64mm) | N/A | 4-1/8" (105mm) | 4-5/8" (117mm) | 3-5/8" (92mm) |

Pulls, push bars and plates
 Push, pull and protection plates

8400/8402

Commercial protection plates (UL and non-UL models)

- All plates, metal and plastic, come standard with four beveled edges and countersunk mounting holes (B-CS)
- Protection plates must be ordered in 1/2" increments. Available in other sizes, consult customer service
- For 8402 UL Plates, UL mark appears in upper left corner. Not available on plastic protection plates (special cutouts are not allowed on UL kick plates)

Specifications

| | |
|--------------------|---|
| Material substrate | <ul style="list-style-type: none"> ▪ Available in .050" thick brass, stainless steel or aluminum; and 1/8" thick high impact polyethylene in clear or black ▪ Aluminum 5005 Series, brass C26800 Series, stainless steel 300 Series, plastic |
| Mounting hardware | <ul style="list-style-type: none"> ▪ Standard mounting package, 16 per pack <ul style="list-style-type: none"> - #6 x 5/8" Oval head screws ▪ Optional Tek/Torx package, specify TK-TX <ul style="list-style-type: none"> - #6 x 5/8" Self-drilling, self-tapping screws - #6 x 5/8" Torx screws |
| Certifications | <ul style="list-style-type: none"> ▪ Meets ANSI/BHMA A156.6 for J301 ▪ UL protection plates certified to UL10C |

Number of screw packs required by plate size (specify Tek screws or Torx screws)

| | 22"-25" | 26"-33" | 34"-41" | 42"-48" |
|---------|---------|---------|---------|---------|
| 4"-8" | 1 | 1 | 1 | 1 |
| 9"-16" | 1 | 1 | 1 | 1 |
| 17"-24" | 1 | 1 | 1 | 2 |
| 25"-32" | 1 | 1 | 2 | 2 |
| 33"-40" | 1 | 2 | 2 | 2 |
| 41"-48" | 2 | 2 | 2 | 2 |

Options

- Specify B-NH for no mounting holes (Not available on 8402. Available only with US32D, US32, US3, US4, US28, CLR, P-BLK only)
- Specify B-NHA for no mounting holes with adhesive (Not available on 8402.)
- Specify ERS prepped with extra row of screws
- Special Cut-outs are available as engineering special, consult customer service

Finishes

| BHMA | Description | Substrate | Finish | Max sizes |
|-------|-------------------------|-----------------|--------------|-----------|
| 605 | Bright Brass | Brass | US3 | 24" x 48" |
| 606 | Satin Brass | Brass | US4 | 24" x 48" |
| 612 | Satin Bronze | Brass | US10 | 24" x 48" |
| 613 | Oil Rubbed Bronze | Brass | US10B | 36" X 46" |
| 619 | Satin Nickel | Stainless | US15 | 24" x 48" |
| 625 | Bright Chrome | Stainless | US26 | 48" X 48" |
| 626 | Satin Chrome | Brass | US26D | 30" x 36" |
| 628 | Satin Aluminum | Aluminum | US28 | 48" x 48" |
| 629 | Bright Stainless Steel | Stainless steel | US32 | 48" x 48" |
| 630 | Satin Stainless Steel | Stainless steel | US32D | 48" x 48" |
| 654 | Satin Stainless Steel | Stainless steel | US32D | 48" x 48" |
| 695 | Dark Bronze Powder Coat | Stainless steel | SP313/US10BE | 24" x 48" |
| BLK | Matte Black | Stainless steel | BLK | 24" x 48" |
| P-BLK | Black | Plastic | P-BLK | 48" x 48" |
| CLR | Clear | Plastic | CLR | 48" x 48" |

Custom finishes are available as engineering special, consult customer service

Available accessories

- Gasket tape kit tape is recommended when using a brass plate on a metal door to reduce tarnishing from electrolytic oxidation
- One tape pack will cover an the perimeters of a 8" x 34" kickplate (Order 8401 gasket tape)

Introduction
 of contents
 and pivots
 and plates
 and coordinators
 and bolts
 and silencers
 hardware
 hardware

WS401/WS402CVX, WS401/WS402CCV

Wall bumpers (convex and concave models)

- Constructed in heavy-duty cast brass
- Special retainer ring makes rubber tamper resistant
- Grey rubber bumper
- WS401/402CVX – convex rubber bumper, packed with fasteners for drywall/wood applications
- WS401/402CCV – concave rubber bumper which avoids damage to locks with projecting buttons, packed with fasteners for drywall/wood applications

Specifications

| | |
|--------------------|--|
| Material substrate | Made from cast brass |
| Certifications | <ul style="list-style-type: none"> ▪ WS401/402CVX Meets ANSI/BHMA 156.16, L12101 ▪ WS401/402CCV Meets ANSI/BHMA 156.16, L12251 |

Dimensions

| Base diameter | Base thickness | Overall projection |
|---------------|----------------|--------------------|
| 2 1/2" | 3/8" | 1" |

Finishes

| BHMA | Description | Substrate | Finish |
|------|-------------------|-----------|--------|
| 605 | Bright Brass | Brass | US3 |
| 606 | Satin Brass | Brass | US4 |
| 612 | Satin Bronze | Brass | US10 |
| 613 | Oil Rubbed Bronze | Brass | US10B |
| 619 | Satin Nickel | Brass | US15 |
| 625 | Bright Chrome | Brass | US26 |
| 626 | Satin Chrome | Brass | US26D |

For other colors, consult factory.

Note: WS401/402 is the full part number. 401 and 402 are not different products.

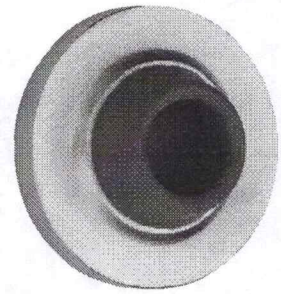

WS401/WS402CCV

WS404CVX

Wall stop (convex)

- Compact size
- Constructed in cast brass
- Totally concealed mounting discourages vandalism or tampering
- Unit furnished with grey convex rubber bumper
- Packed with fasteners for drywall/wood applications

Specifications

| | |
|--------------------|----------------------|
| Material substrate | Made from cast brass |
|--------------------|----------------------|

Dimensions

| Base diameter | Overall projection |
|---------------|--------------------|
| 1" | 17/32" |

Finishes - brass

| BHMA | Description | Substrate | Finish |
|------|-------------------|-----------|----------|
| 605 | Bright Brass | Brass | US3 |
| 606 | Satin Brass | Brass | US4 |
| 609 | Blackened Brass | Brass | US5 |
| 612 | Satin Bronze | Brass | US10 |
| 613 | Oil Rubbed Bronze | Brass | US10B |
| 619 | Satin Nickel | Brass | US15 |
| 622 | Matte Black | Brass | BLK |
| 625 | Bright Chrome | Brass | US26 |
| 626 | Satin Chrome | Brass | US26D |
| - | Aged Bronze | Brass | 643e/716 |

For other colors, consult factory.



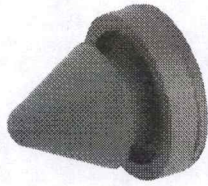

Meets ANSI/BHMA 156.16, L03011.

SR64 Door Silencer

- For use on metal frames featuring pneumatic design that, once installed, forms an air pocket to absorb shock and reduce noise of door closing.
- Tamper-proof once installed on the frame.
- Proper installation also eliminates door rattle and provides constant tension for door latches or locks.

Packed in bags of 100.
 Grey Available in bulk pack of 2500.
 Each bag has an installation tool included.

Dimensions

Diameter: 1/2"

Thickness: 1/8"

Finishes

GRY, TAN



Meets ANSI/BHMA 156.16, L03021

SR65 Door Silencer

- For use on wood frames, also feature pneumatic design to cushion shock and absorb noise.
- To prevent removal, a small brad should be driven into stop strip and through stem of silencer, as shown in the detail.

Packed in bags of 100.

Dimensions

Height: 3/4"

Diameter: 3/8"

Thickness: 1/8"

Finishes

GRY



SR66 Door Silencer

- Self Adhesive Rubber Silencers.
- Economical installation requires no drilling of frames.

Packed two sheets of 50 (100 minimum).

Dimensions

Diameter: 1/2"

Thickness: 1/8"

Finishes

BRN, GRY, WHT

Hinges & Pivots

Pulls & Plates

Flush Bolts & Coordinators

Latches, Catches & Bolts

Stops

Exterior Hardware

Miscellaneous Hardware