

MATCHLINE, SEE SHEET G

MATCHLINE, SEE SHEET E

MATCHLINE, SEE SHEET I

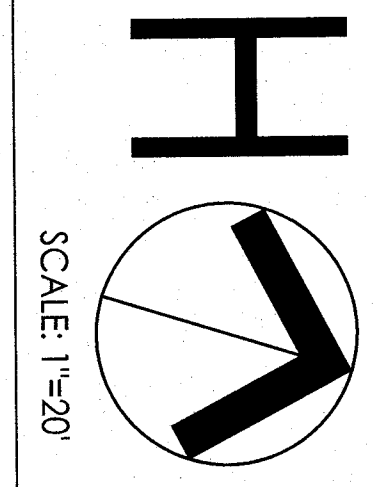
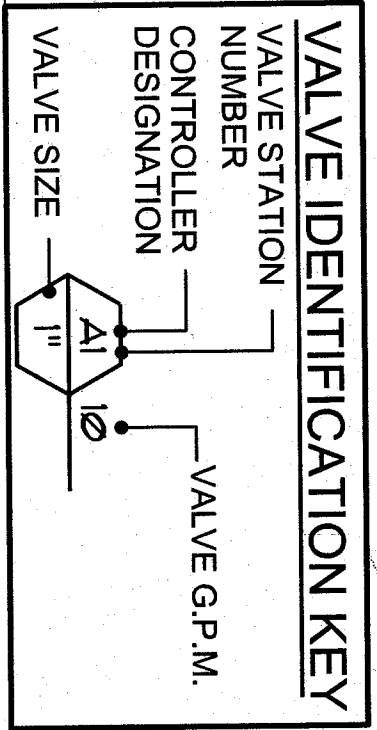
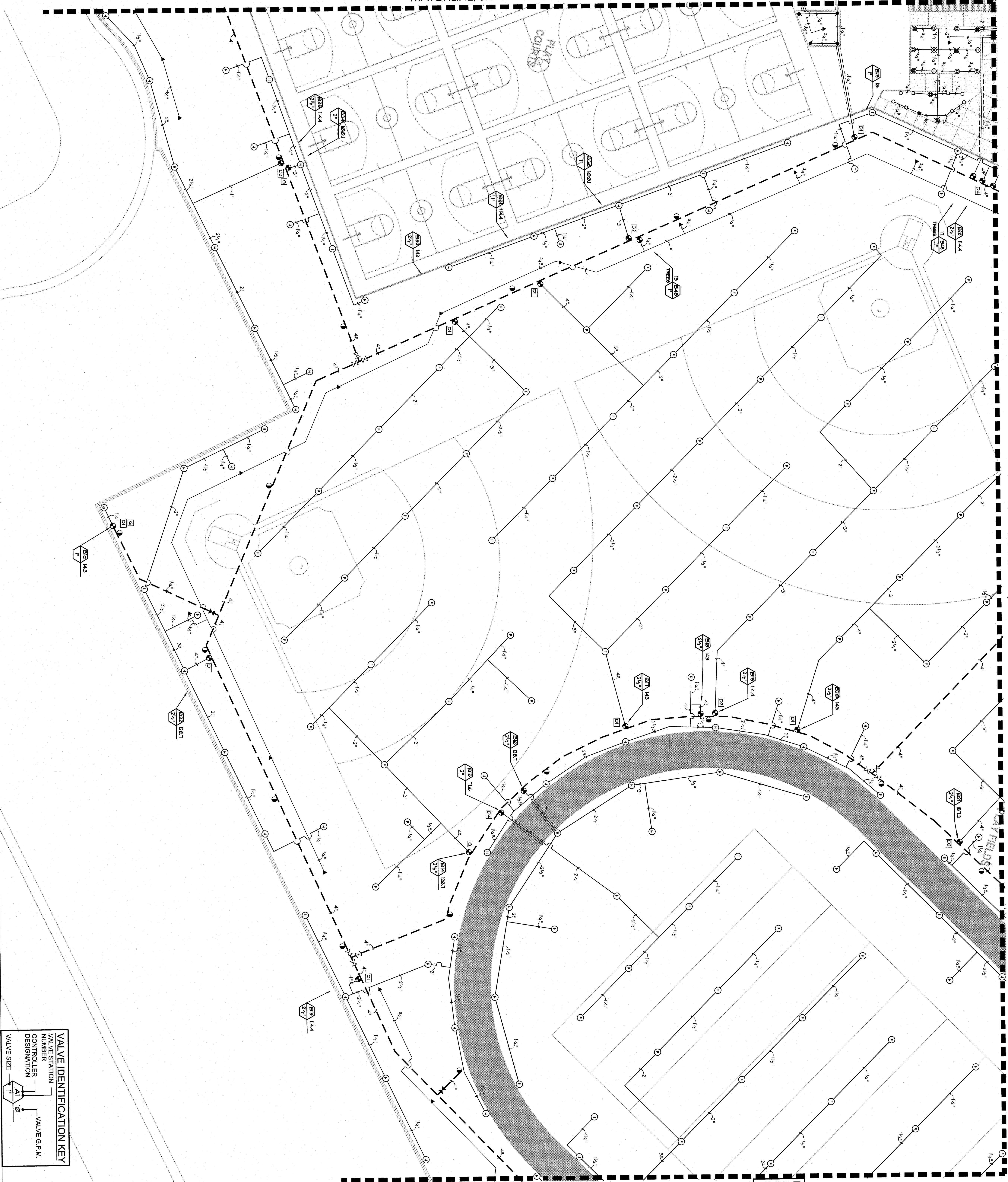

SCALE: 1"=20'

NOTES
 REFER TO SHEET L10 FOR
 IRRIGATION LEGEND AND NOTES
 REFER TO SHEET L11, L12 & L13
 FOR IRRIGATION DETAILS

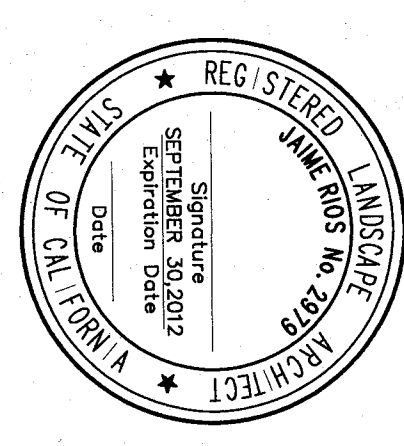

RIOS DESIGN STUDIO
 LANDSCAPE ARCHITECTURE & DESIGN
 3805 OAK VISTA AVENUE
 BAKERSFIELD, CALIFORNIA
 93309
 P: 661.855.5292
 F: 661.857.5284

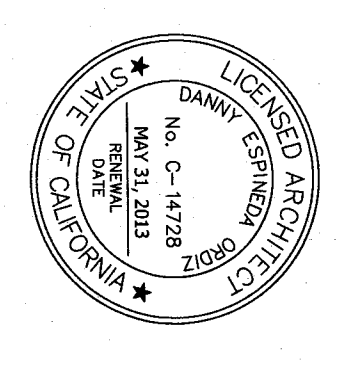
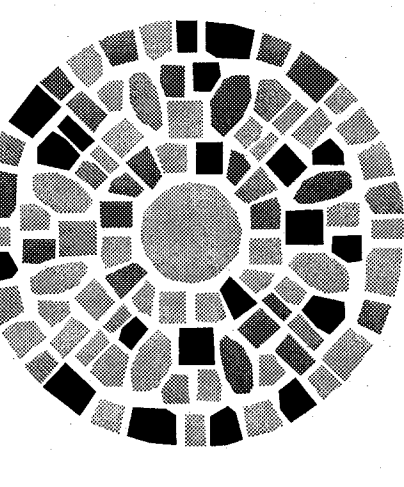

ORDIZ MELBY
 ARCHITECTS, INC.
 5500 WING AVENUE SUITE 200
 BAKERSFIELD, CALIFORNIA 93309
 TELEPHONE (661) 332-6288
 FACSIMILE (661) 332-4251

IDENTIFICATION STAMP
 DIVISION OF STATE ARCHITECT
 OFFICE OF REGULATION SERVICES
 FILE #: 154
 AC: 113 93
 DATE: 10/26/11
 PIN# 88334112

FOR:
 NEW ELEMENTARY SCHOOL
 9801 HIGHLAND KNOLLS DR
 BAKERSFIELD CALIFORNIA 93308
 NEW MIDDLE SCHOOL
 4115 VINELAND ROAD
 BAKERSFIELD CALIFORNIA 93308

BAKERSFIELD CITY SCHOOL DISTRICT
 1300 BAKER STREET
 BAKERSFIELD CALIFORNIA 93305

MARK	DATE	DESCRIPTION
△		
△		
△		
△		

DESIGNED BY: DANNEY E. ORDIZ
 DRAWN BY: WILLIAM J. MELBY
 1244-BLDG A (MULTIPURPOSE)-CD.dwg
 201101244

CHECK AND VERIFY ALL DIMENSIONS BEFORE REPORT FOR CONSTRUCTION TO THE ARCHITECT. THE DRAWINGS, SPEC AND RESOURCES ARE THE PROPERTY OF THE ARCHITECT. CONSULT THE ARCHITECT FOR ANY CHANGES.
 ORDIS ARCHITECTS, INC. 2010
 SHEET TITLE

IRRIGATION PLAN
 SHEET IDENTIFICATION NUMBER
L9